



You can rely on Defy. To simplify.

EN

INSTRUCTION MANUAL

Refrigerators

Record in the space below the listed information for future reference.

SERIAL NUMBER.....

DATE OF PURCHASE.....

PURCHASED FROM.....

.....

The manufacturer strives for continuous improvement.
For this reason, the text and illustrations in this manual
are subject to change without notice.

Part number
14875



Read this manual before initial installation and operation of the product!

Dear customer,

Your new Defy refrigerator was manufactured in a state of the art facility and has passed the strictest quality control procedures.

Please read this manual carefully before using your product for the first time and then store it within easy reach for future reference.

We trust you will enjoy years of trouble free use.

The user manual:

- This manual will provide you with information on how to safely operate and care for your refrigerator in order that you gain the maximum benefit from it.
- Pay particular attention to any safety instructions.
- Please read all additional documents supplied with your refrigerator.
- Please note that this manual may be used for several similar but different models. Please check for relevance regarding your particular model.

Explanation of symbols used in this manual



Important safety information. Warning for hazardous situations with regard to life and property.



Caution; Warning for supply voltage.



Caution; Warning for fire hazard.



Caution; Warning for hot surfaces.



Read the instructions.



Useful information. Important information or useful hints about usage.

Unpacking

Remove all packaging. Ensure that packing material is disposed of in a responsible manner and that any plastic bags are cut up to prevent children playing with them and accidentally suffocating. If the refrigerator is damaged in any way do not use it. Report the damage to your dealer who will take the necessary corrective action.

PLEASE REGISTER YOUR PRODUCT AT

www.defy.co.za

DEFY APPLIANCES (PTY) LTD

P.O.BOX 12004

JACOBS



DURBAN

4026

SOUTH AFRICA

Contents

<u>Important Safety Information</u>	4	<u>Maintenance and cleaning</u>	11
Warnings	4	Replacing the light bulb	11
Child safety	5	Owners responsibility	11
HCA Warning	5		
Things to be done for energy saving	6	<u>Trouble Shooting</u>	12
<u>Installation</u>	6	<u>Service Centres</u>	14
Points to be considered when re-transporting your refrigerator	6		
Before operating your refrigerator	6	<u>Warranty</u>	15
Electrical connection	6		
Adjusting the feet	7		
Placing and installation	7		
<u>Model Selection</u>	8		
Operating the refrigerator	8		
Storage guide	8		
<u>The freezer compartment</u>	9		
Deep freeze information	9		
Defrosting	10		
Door opening	10		

	The manufacturer strives for continuous improvement. For this reason, technical specifications, text and illustrations in this manual are subject to change without notice.
	Figures in this manual are schematic and may not match your refrigerator exactly.
	Values stated on the machine labels or in the documentation accompanying it are obtained in laboratory conditions in accordance with the relevant standards. Depending on operational and environmental conditions of the machine, these values may vary.

Important safety information

Please review and observe the following information. Failure to do so may result in injuries or material damage and will render any warranty and reliability commitments void. The usage life of the refrigerator you have purchased is 10 years. This is the time period that spare parts will be stocked for the refrigerator to meet any maintenance or service requirements.



This refrigerator is not intended for use by persons (including children) with reduced physical, sensory or mental capabilities or lack of experience and knowledge, unless they have been given supervision or instruction concerning the use of the refrigerator by a person responsible for their safety. Children should be supervised to ensure that they do not play with the refrigerator.

Warnings



- Hand this owners manual over to the new owner should ownership change.
- The refrigerator must only be used for its intended purpose, i.e. the storing of edible foodstuff.
- The refrigerator is intended to be used in household and similar applications such as staff kitchen areas in shops, offices and other working environments; farm houses and by clients in hotels, motels and other residential type environments; bed and breakfast type environments; catering and similar non-retail applications.
- Consult with your authorised DEFY service centre for all questions and problems relating to the refrigerator. Only authorised agents are to carry out repairs.
- Vapour and vaporized cleaning materials must never be used in the cleaning and defrosting the refrigerator. The vapour may come into contact with the electrical parts and cause a short circuit or electric shock.
- Do not allow children to hang on the refrigerator door as the unit could topple forward risking personal injury. Never use the parts on your refrigerator, such as the door, as a means of support or step.
- Do not use electrical appliances inside the refrigerator or freezer.
- Do not drill, cut or modify the refrigerator. Injuries may result if the refrigerant circuit

is damaged. See HCA warning overleaf. Do not damage the refrigerant circuit.

- Keep ventilation openings, in the refrigerator or in the built-in structure, clear of obstructions.
- Unplug the refrigerator when cleaning, during routine maintenance or if it will not be used for an extended period.
- To unplug the refrigerator, remove the plug by pulling on the plug and not the cable!
- Exposing the refrigerator to rain, snow, sun and wind is an electrical safety risk.
- Should the mains lead of the refrigerator become damaged or should it need replacing at any time, it must be replaced by a special purpose made mains lead which can only be obtained from a DEFY Authorised Service Agent.
- Never connect your refrigerator to electricity saving systems as they may damage the refrigerator.
- Do not store medicine or academic research samples which require strict temperature control in the refrigerator.
- Do not store or use flammable gas, benzene, petrol or volatile substances in or near the refrigerator.
- Do not store explosive substances such as aerosol cans with a flammable propellant in the refrigerator.
- In the event of a malfunction, disconnect the refrigerator from the power supply.
- Do not overload your refrigerator with excessive amounts of food. If overloaded, the food items may fall down and injure you and damage the refrigerator when you open the door. Never place objects on top of the refrigerator, they may fall down and injure you when you open or close the refrigerator door.

	Do not operate a damaged refrigerator. Consult with your nearest DEFY service centre should you have any concerns
	The electrical safety of the refrigerator is only guaranteed if the earth system of your home is compliant to national standards.
	Never plug the refrigerator into the wall socket during installation. Death or serious injury may result.

- The refrigerator may move if the adjustable legs are not properly levelled on the floor. Levelling the adjustable legs on the floor helps prevent the refrigerator from moving.
- When carrying the refrigerator, do not hold on the door handle as this may cause the handle to break.
- When placing your refrigerator next to another refrigerator or freezer, the distance between the devices should be at least 80 mm. Failure to do so may cause adjacent walls to humidify.
- For refrigerators with a freezer compartment; Do not put bottled and canned liquid beverages in the freezer compartment as they may burst.
- Do not touch frozen food with your hands; they may stick to your hand.
- Never pour or spray water into or on the refrigerator and do not store liquids, pot plants or open containers on top of the refrigerator as these might spill causing electrical shorting.
- For manually controlled refrigerators, wait at least 5 minutes before starting the refrigerator after a power failure.
- Avoid any damage to the power cable when transporting the refrigerator.
- Bending the cable may cause a fire.
- Never place heavy objects on the power cable.
- Do not touch the plug with wet hands.
- Do not plug in the refrigerator if the wall socket is loose.
- On delivery, check to make sure that the refrigerator is not damaged and that all the parts and accessories are in perfect condition.
- Ensure that the plug remains readily accessible. Do not use multiple adapter plugs or an extension cable.
- Ensure that there is sufficient spacing between the refrigerator and surrounding walls.

	Warning: Repairs must be carried out by authorised persons only. Repairs carried out by incompetent persons create a user risk.
	Unplug the refrigerator from the wall socket when you clean the refrigerator.

Child safety

- If the door has a lock, the key should be kept out of reach from children.
- If you are discarding an old refrigerator with a lock or latch fitted to the door, disable the lock/latch, and ensure that the refrigerator is left in a safe condition to prevent children from being trapped inside and suffocating.
- Children must be supervised to prevent them from tampering with the refrigerator.

HCA Warning



Refrigerator cooling systems containing R600a:

Refrigerators containing non CFC / HFC natural substances in the cooling system (Called R600a) and in the insulation (Called cyclopentane). Please note that these substances are potentially flammable if exposed to fire.

Therefore, take care not to damage, the cooling circuit / pipes of the refrigerator in transportation and in use.

In case of damage do not expose the refrigerator to fire or potential ignition sources and immediately ventilate the room where the refrigerator is situated.

Ignore this warning if your refrigerators cooling system contains R134a.

	Warning: Never dispose of the Refrigerator in a fire.
	Do not dispose of your Refrigerator along with regular household waste.

Contact your local authority for disposal information and facilities available.

Things to be done for energy saving

- Do not leave the doors of your refrigerator open for long periods of time.
- Do not put hot food or drinks in your refrigerator.
- Do not overload your refrigerator. This restricts effective air circulation in the refrigerator.
- Do not install your refrigerator under direct sunlight or near heat emitting appliances such as ovens, dishwashers or radiators. Pay attention to keep your food in closed containers.
- For refrigerators with a freezer compartment; You can store maximum amount of food items in the freezer when you remove the shelf or drawer of the freezer. The energy consumption value stated for your refrigerator has been determined by removing the freezer shelf or drawer and under maximum load. There is no harm in packing a shelf or drawer with a variety of different shapes and sizes of food to be frozen.
- Thawing frozen food in the fridge compartment will provide both energy saving and preserve the food quality.

Installation

Please remember that the manufacturer shall not be held liable if the information given in the instruction manual is not followed.

Points to be considered when re transporting your refrigerator

1. Your refrigerator must be emptied and cleaned prior to any transportation.
2. The shelves, accessories, crisper etc. In your refrigerator must be fastened securely with adhesive tape to protect against any jolts before repackaging.
3. Packaging must be tied with thick tape and strong rope and the transportation guidelines printed on the package must be followed.

Before operating your refrigerator

Before using your refrigerator please note the following:

- Is the interior of the refrigerator dry and can the air circulate freely at the rear of it?
- Clean the interior of the refrigerator as recommended in the “Maintenance and cleaning” section.
- Plug the refrigerator into the wall socket. When the fridge door is open the fridge compartment interior light will come on.
- You may hear a noise as the compressor starts up. The liquid and gases sealed within the refrigeration system may also give rise to noise, even if the compressor is not running, this is quite normal.
- The front edges of the refrigerator may feel warm. This is normal. These areas are designed to be warm to avoid condensation.



Electrical connection

Connect your refrigerator to a grounded socket which is protected by a fuse with the appropriate capacity.

Important

The connection must be in compliance with national regulations.

- The power cable plug must be easily accessible after installation.
- The specified voltage must be equal to your mains voltage.

	A damaged power cable must be replaced by a qualified electrician.
	Extension cables and multiway plugs must not be used for connection.
	A damaged refrigerator must not be operated before it is repaired! There is danger of an electric shock!

Adjusting the feet

If your refrigerator is unbalanced

The refrigerator may move if the adjustable legs are not properly levelled on the floor.

Levelling the adjustable legs on the floor:

It is essential to level the refrigerator by turning the two adjustable levelling feet at the front, either in or out. (See figure below)

The corner where the legs are is lowered when the leg is turned in the direction of the black arrow and raised when turned in the opposite direction.

Having someone to carefully assist in tilting the refrigerator slightly will help facilitate this process.

It is advisable to adjust the cabinet so that it tilts slightly backwards. This will assist the doors to close by themselves. It will also ensure proper drainage of defrost water from the rear wall.

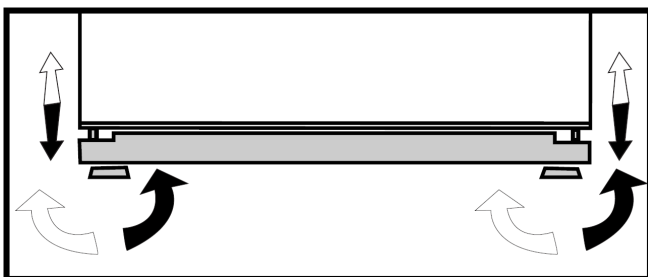

	<p>Your refrigerator should be installed at least 300 mm away from heat sources such as hobs, ovens, central heaters and stoves and at least 50 mm away from electrical ovens and should not be located under direct sunlight.</p>
	<p>If two refrigerators are to be installed side by side, there should be at least 20 mm distance between them.</p>

Placing and Installation

If the entrance door of the room where the refrigerator is to be installed is not wide enough for the refrigerator to fit through, then call an authorized service centre and have them remove the doors of your refrigerator in order that the refrigerator can fit sideways through the door.

1. Install your refrigerator in a place that allows for ease of use.
2. Keep your refrigerator away from heat sources such as stoves, geysers humid places and direct sunlight.
3. There must be appropriate air ventilation around your refrigerator in order to achieve efficient operation.
The refrigerator is to have at least a 50 mm space from the ceiling and at least a 50 mm space from the wall.
If the floor is covered with a carpet, your refrigerator must be elevated 25 mm from the floor.
4. Place your refrigerator on an even floor surface to prevent jolts.
5. Do not keep your refrigerator in ambient temperatures under 10°C.

Please make sure that the interior of your refrigerator is cleaned thoroughly.

When operating your refrigerator for the first time, please observe the following instructions during the initial six hours:

- The door should not be opened frequently.
- The refrigerator must be operated empty without any food in it.
- Do not unplug your refrigerator. If a power failure occurs out of your control, please see the warnings in the “Recommended solutions for the problems” section.
- Original packaging and foam materials should be kept for any future transportation or moving.

Model selection

Defy manufactures both top and bottom freezer models.

The instructions in this manual are applicable to both types.

Operating the refrigerator

Switching on and setting the temperature

- Push the 15-amp plug into an earthed wall socket and switch on the power.
- Ensure that the thermostat (located at the interior lamp housing) is not in the OFF position.
- A setting midway on the dial should generally give satisfactory results.
- If however you require a colder interior temperature, turn the thermostat knob to the right. If you require a warmer interior temperature, turn the thermostat knob to the left.

Storage guide

- Do not cover the shelves with paper or anything which could prevent airflow between the shelves.
- The shelves may be adjusted up or down depending on storage requirements. Pull the shelf forwards and out.
- Reposition at a different level.
- Avoid placing food wrapped in paper against the rear wall of the refrigerator. The paper could freeze to the wall and later, during defrosting, slide into and block the defrost water drain located in the trough at the bottom of the rear wall. (Keep the drain key inserted)
- Foods with strong aromas should be stored in sealed containers to prevent flavour transfer to other foods.
- Separate vegetable crispers enable non-compatible foods to be stored without one tainting the other.

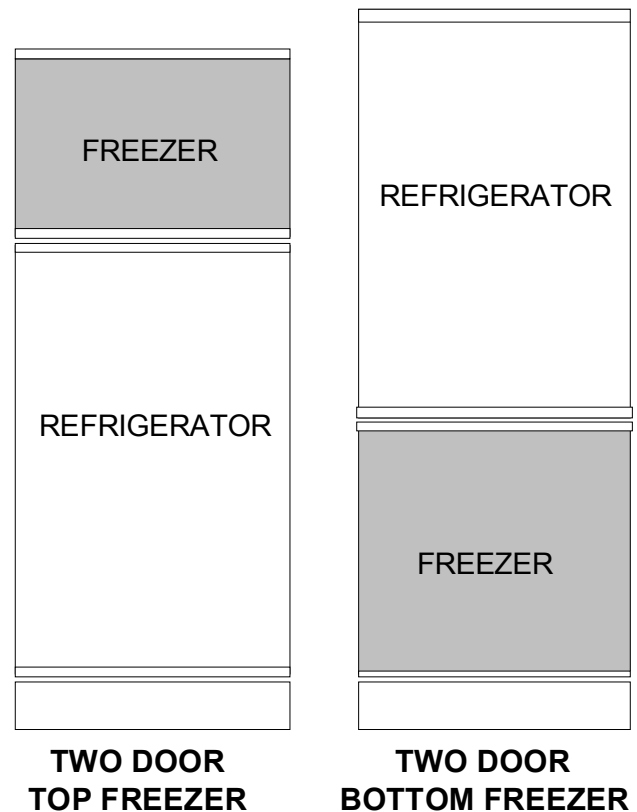

- The “Drain Key”, is supplied in the accessory pack and should be inserted into the defrost water drain on the interior rear wall of the refrigerator compartment.
- When in place, the key will allow defrost water to escape but will prevent loose debris from blocking the drain.

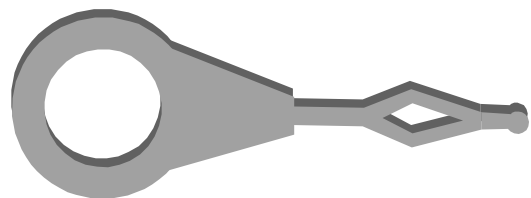

DRAIN KEY

The freezer compartment

Deep-freeze information

- **Operate the freezer for 12 hours before loading it.**

- Food must be frozen as rapidly as possible when placed in a freezer to maintain its quality.
- It is possible to keep food for a long time period only at temperatures of -18 degrees C or lower.
- The quality of food in a freezer can be maintained for many months at temperatures of -18 degrees C or lower.
- Pre-packed commercially frozen food should be stored in accordance with the frozen food manufacturer's instructions for a (4 star) frozen food storage compartment.
- To ensure that the high quality achieved by the frozen food manufacturer and the food retailer is maintained, the following should be remembered:
Put packages in the freezer as quickly as possible after purchase. Ensure that contents are labelled and dated. Do not exceed "Use By" or "Best Before" dates on the packaging.
If there is a power failure do not open the freezer door. Even if the power failure lasts up to the "Temperature rise time" as indicated on the refrigerator specifications table, frozen food will not be affected. In case the failure lasts longer, the food must be checked and when necessary, must be consumed immediately or must be frozen after being cooked.
- Wrap all food before storage. Seal all foods, or place in airtight containers to prevent dehydration.
- Eliminate all the air pockets from packages and keep air out by firm sealing.
- When packaging in sheet material such as aluminium foil, parcel tightly and press out all air pockets. All folds should be sealed with deep-freeze sealing tape.

- Unwrapped food containing acids or salt may permanently stain the cabinet interior.
- When loading bulk into the freezer, load one quarter at a time and allow to freeze before loading the next quarter.
- Divide food into reasonable portions according to your requirements.
- Allow hot food to cool before putting it into the freezer. Freeze cooked food in small quantities. This ensures rapid freezing and maintains the quality of the food.
- Food that has defrosted must be consumed within 24 hours. Only cooked food can be refrozen. Do not re-freeze food that has defrosted.
- Do not exceed the expiry date shown on food packs.
- Do not take out frozen food with wet hands. Your hands could stick to the frozen food.
- Always use appropriate packaging material to avoid odour penetration or degradation of the food.
- Transport pre-frozen food from the supermarket in foil lined cooler bags and transfer to the home freezer as soon as possible.
- Never exceed the maximum freezing capacity of the freezer.
- Do not freeze too large a quantity of food at any one time. The quality of the food is best preserved when it is frozen right through to the centre as quickly as possible. Take special care not to mix already frozen food and fresh food.



Note If you find that the door of the freezer is difficult to open just after you have closed it, this is due to the pressure difference which will equalize and allow for the door to be opened normally after a few minutes.

- The baskets (fitted to bottom freezer models) may be partially or completely pulled out to facilitate loading. They are not all the same size and care should be taken, after cleaning or loading, to replace them in the original order to ensure a correct fit.
- The calendar on the inside of the freezer door serves as a guide and shows the safe storage period (in months) for the depicted foods.

Door opening

- Please note that when the door is closed a partial vacuum is created which sucks the door tightly against the cabinet.
- Opening the door immediately thereafter may require more pulling force than normal to break the suction effect. After a period of time pressures will stabilise and the door will once more open normally.

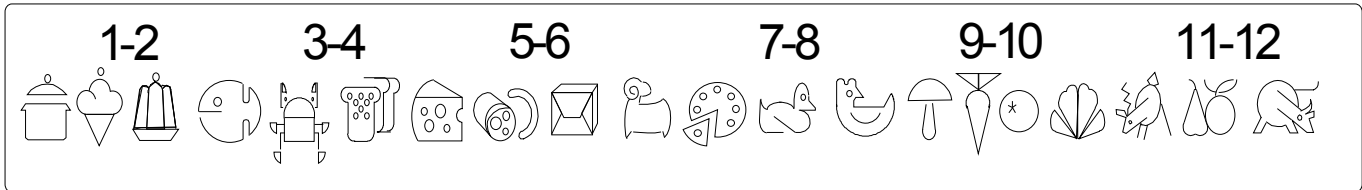

Defrosting

Refrigerator compartments defrost automatically and no further action is required.

Freezer compartments however need to be manually defrosted whenever the frost build up inside the freezer reaches a thickness of 4 mm.

To defrost the freezer compartment, proceed as follows:

- Switch off the power at the wall socket.
- Remove contents and store in a cool place.
- Leave the door open during defrosting.
- When the frost begins to soften, wipe it up.
- When defrosting is complete, clean and dry out the compartment.
- **Replace the ice tray shelf / baskets (where fitted) and the frozen food.**
- Switch on the power at the wall socket and resume normal operation.

DO NOT ATTEMPT TO REMOVE THE FREEZER SHELVES ON 320 AND 380 MODELS ONLY

Caution

Never attempt to scrape frost or ice off the freezer walls or shelves.

	Warning: Do not use mechanical devices or other means to accelerate the defrosting process,
	Warning: Do not attempt to remove the freezer shelves on 320 and 380 models only.
	Warning: Unplug the refrigerator from the wall socket when you defrost the refrigerator.
	Do not use electrical appliances inside the food storage compartments of the appliance

Maintenance & Cleaning

Always disconnect the plug from the mains socket before cleaning.

Note that turning the thermostat to '0' does not switch the power off to the refrigerator.

- Clean the inside of the refrigerator when necessary by using a solution of one table spoon of Bicarbonate of Soda to two litres of warm water.
- Dry with a soft cloth.
- Do not use pot scourers or abrasive powders to clean the refrigerator.
- Spillages, especially citric and acidic juices, must be wiped up immediately as they could stain the interior of the refrigerator.
- Always ensure that the defrost drain, on the rear wall of the refrigerator compartment, is clean and free of obstructions. (Keep the Drain Key inserted –see page 8).

Refrigerator shelves, ice tray shelf and freezer baskets, where fitted, may be removed for cleaning purposes. (DO NOT ATTEMPT TO REMOVE THE FREEZER SHELVES ON 320 AND 380 MODELS ONLY).

- The back of the refrigerator may be vacuumed or dusted using a soft bristle brush.
- A mild furniture polish may be used on the exterior cabinet to add lustre and protect against finger marks.

Replacing the light bulb



NOTE: Always keep the top refrigerator door shelf in place as it is used to trigger the interior light switch.

- Unplug the power cord at the wall socket.
- Unclip the light cover by gently pulling the rear edge forward.
- Unscrew the bulb and replace it with a similar bulb having a power rating that does not exceed 15 watts.
- Replace the light cover by inserting the clip on its front edge into the slot of the thermostat housing and then snapping in the clip on the rear edge.

Owner's responsibility

Since the following are not factory faults they are the owners responsibility:

- Damage to the exterior finish.
- Breakage of glass and other components.
- Replacement of light bulbs.
- Damage caused through improper use of the appliance.
- Damage caused by moving the appliance.
- Blocked defrost drain (refrigerator section).

	Warning: Repairs must be carried out by authorised persons only. Repairs carried out by incompetent persons create a user risk.
	Unplug the refrigerator from the wall socket when you clean the refrigerator.

Trouble Shooting



Please review this list before calling a service centre. It could save you time and money. This list includes frequent complaints that do not arise from defective workmanship or material usage. Some of the features described here may not apply to your model.

Symptom	Check
The refrigerator does not operate.	<ul style="list-style-type: none"> • Make sure the refrigerator plug is securely plugged in. • Check for a blown fuse or tripped circuit breaker. • Test the wall socket for power using another appliance. • Inspect the electrical cord for damage. • Eliminate the use of an extension cord, if any is being used.
Condensation on the side wall of the fridge compartment	<ul style="list-style-type: none"> • Very cold ambient conditions. Frequent opening and closing of the door. Highly humid ambient conditions. Storage of food containing liquid in open containers. Leaving the door ajar. Switching the thermostat to a colder degree. • Decreasing the amount of time the door is left open or using it less frequently. • Covering the food stored in open containers with a suitable material. • Wipe the condensation using a dry cloth and check if it persists.
Compressor is not running.	<ul style="list-style-type: none"> • The protective thermal fuse of the compressor will blow out during sudden power failures or plug-outs and plug-ins as the refrigerant pressure in the cooling system of the refrigerator has not yet been balanced. Your refrigerator will start running approximately after 15 minutes. Please call a service centre if the refrigerator does not start up at the end of this period. • The refrigerator is in defrost cycle. This is normal for an automatic defrosting refrigerator. The defrosting cycle occurs periodically. • Your refrigerator is not plugged into the wall socket. Make sure that the plug is properly fitted into the wall socket. • Have the temperature adjustments been correctly made? • Power might be cut off.
The fridge is running continuously or for a long time.	<ul style="list-style-type: none"> • Your new refrigerator may be wider than the previous one. This is quite normal. Large refrigerators operate for a longer period of time. • The ambient room temperature may be high. This is quite normal. • The refrigerator might have been plugged in recently or might have been loaded with food. Cooling down of the refrigerator completely may take longer. • Large amounts of hot food might have been put in the refrigerator recently. Hot food causes longer running of the refrigerator until the food has cooled down. • Doors might have been opened frequently or left ajar for a long time. The warm air that has entered into the refrigerator causes the refrigerator to run for longer periods. Open the doors less frequently. • The freezer or fridge compartment door might have been left ajar. Check that the doors are tightly closed. • The refrigerator is adjusted to a very low temperature. Adjust the refrigerator temperature to a warmer degree and wait until the temperature is achieved. • The door seal of the fridge or freezer may be soiled, worn out, broken or not properly seated. Clean or replace the seal. A damaged/broken seal causes the refrigerator to run for a longer period of time in order to maintain the current temperature. • Check if the freezer needs defrosting. (Manual defrost models).
The interior light switches on but the unit won't run.	<ul style="list-style-type: none"> • Check the temperature settings. • Ensure there is 75mm outside of the refrigerator between the walls and the back and sides and at least a 25 mm gap above to allow for air flow. • Unplug the refrigerator, wait 2 hours and plug it back in again. If you hear it running, a problem is causing the compressor to overheat.
The interior light does not switch on.	<ul style="list-style-type: none"> • Replace the bulb with a new one not exceeding 15W. • Test the door switch.

Symptom	Check
Freezer temperature is very low while the fridge temperature is sufficient.	<ul style="list-style-type: none"> The freezer temperature is adjusted to a very low temperature. Adjust the fridge temperature to a warmer degree and check if the fridge temperature is still sufficient.
Fridge temperature is very low while the freezer temperature is sufficient.	<ul style="list-style-type: none"> The fridge temperature might have been adjusted to a very low temperature. Adjust the fridge temperature to a warmer degree and check.
Food in fridge compartment drawers is freezing.	<ul style="list-style-type: none"> The fridge temperature might have been adjusted to a very low temperature. Adjust the fridge temperature to a warmer degree and check.
Temperature in the fridge or freezer is very high.	<ul style="list-style-type: none"> The fridge temperature might have been adjusted to a very high degree. Fridge adjustment has an effect on the temperature of the freezer. Change the temperature of the fridge or freezer until the fridge or freezer temperature reaches a sufficient level. Doors might have been opened frequently or left ajar for a long time; open them less frequently. Door might have been left ajar; close the door completely. Large amount of hot food might have been put in the refrigerator recently. Wait until the fridge or freezer reaches the desired temperature. The refrigerator might have been plugged in recently. Complete cooling down of the refrigerator takes time.
The operating noise increases when the refrigerator is running.	<ul style="list-style-type: none"> The operating performance of the refrigerator may change due to the changes in the ambient temperature. It is normal and not a fault.
Vibrations or noise.	<ul style="list-style-type: none"> The floor is not even or it is weak. The refrigerator rocks when moved slowly. Make sure that the floor is strong enough to carry the refrigerator, and level. The noise may be caused by the items put onto the refrigerator. Items on top of the refrigerator should be removed. Check the water defrost water drain pan on top of the compressor. Inspect the compressor mounts.
There are noises coming from the refrigerator like liquid spilling or spraying.	<ul style="list-style-type: none"> Liquid and gas flow occur in accordance with the operating principles of your refrigerator. It is normal and not a fault.
Noise like wind blowing.	<ul style="list-style-type: none"> Fans are used in order to cool the refrigerator. It is normal and not a fault.
Condensation on the inner walls of refrigerator.	<ul style="list-style-type: none"> Hot and humid weather increases icing and condensation. It is normal and not a fault. Doors might have been left ajar; make sure that the doors are fully closed. Doors might have been opened frequently or left ajar for a long time.
Humidity occurs on the outside of the refrigerator or between the doors.	<ul style="list-style-type: none"> There might be humidity in the air; this is quite normal in humid weather. When the humidity is less, condensation will disappear.
Bad odour inside the refrigerator.	<ul style="list-style-type: none"> The inside of the refrigerator must be cleaned. Clean the inside of the refrigerator with a sponge, lukewarm water or carbonated water. Some containers or package materials might cause the smell. Use a different container or different brand of packaging material.
The door is not closing.	<ul style="list-style-type: none"> Food packages may prevent the door's closing. Repack the packages that are obstructing the door. The refrigerator is not completely level on the floor and rocks when slightly moved. Adjust the elevation screws. The floor is not level or strong. Make sure that the floor is level and capable of carrying the weight of the refrigerator.
Crispers are stuck.	<ul style="list-style-type: none"> Food may be touching the drawer ceiling. Rearrange the food in the drawer.

Defy Service Centres

If you have followed the instructions and still have a problem, contact the nearest Defy Service Centre. They will be able to advise you on any aspect of the product or send a qualified technician to repair it.

BLOEMFONTEIN 160 Long Street, Hilton,
Bloemfontein 9301.
Tel. 051 400 3900
Bloemfontein.Service@defy.co.za

CAPE TOWN 5A Marconi Rd.
Montague Gardens, 7441.
Tel. 021 526 3000
CapeTown.Service@defy.co.za

DURBAN 35 Intersite Avenue,
Umgeni Business Park, Durban 4051.
Tel. 031 268 3300
Durban.Service@defy.co.za

EAST LONDON 16 Bowls Rd. Arcadia,
East London 5201.
Tel. 043 743 7100
EastLondon.Service@defy.co.za

JOHANNESBURG Cnr. Mimetes & Kruger Sts. Denver ext.12
Commercial Head Office,
Administration, Distribution, National Groups,
Tel. Sales, Contracts and Credit.
Johannesburg. 2094.
Tel. 011 621 0200 or 011 621 0300
Gauteng.Service@defy.co.za

POLOKWANE 87 Nelson Mandela Drive.
Superbia 0699.
Tel. 0152 92 1166 / 7 / 8 / 9.
Polokwane.Service@defy.co.za

PORT ELIZABETH 112 Patterson Road,
North End, Port Elizabeth 6001.
Tel. 041 401 6400
PortElizabeth.Service@defy.co.za

PRETORIA. Block A1 Old Mutual Industrial Park.
Cnr. D.F.Malan Drive & Moot Str.
Hermanstad. 0082.
Tel. 012 377 8300

**OTHER AREAS ARE SERVICED BY OVER 200 AUTHORISED AGENTS. FOR FURTHER
DETAILS PLEASE CONSULT THE NEAREST REGIONAL DEFY SERVICE CENTRE**

Warranty

This certificate is issued by DEFY APPLIANCES LIMITED manufacturers of Defy and Ocean products, hereinafter the Company, to the original purchaser only, of the appliance described on the certificate and shall constitute the only warranty given in respect of this appliance.

The Company warrants to the original purchaser that for a period of TWO YEARS from date of purchase the appliance is free from defect under normal domestic use, both in workmanship and material, subject to the following conditions.

1. Repair or replacement of any part of this appliance, found by the Company to be defective, shall be at the election of the Company. The Company reserves the right to effect such service through any of its Service Divisions or Authorised Service Dealers. The cost of such service shall be borne by the Company in full, provided that the appliance is located no further than 50km from a Company Service Centre or an Authorised Service Dealer. Where the appliance is located beyond the 50km radius, the purchaser shall be liable for the standard travelling charges, as determined by the Company.
2. Vitreous enamelware, fuses and lamps are specifically excluded from these warranties. It is an express condition of these warranties that the purchaser takes due care and attention in the use and maintenance of the appliance. Abuse, misuse in conflict with operating instructions, connection to incorrect voltages and subjection to commercial use shall release the Company from its obligations.
3. This warranty shall become void and cease to operate if the appliance is dismantled by, or any repairs to the appliance are effected by any persons not duly authorised by the Company, or if substitute parts not approved by the Company are used in the appliance, or if the serial number of the appliance is removed.
4. The Company shall not be responsible for damages resulting from fire, flood, civil disturbances or any Act of God. The Company shall not, in terms of these warranties be responsible nor held liable for any consequential loss or damage of any kind caused by or due to the failure or malfunction of the appliance.
5. The Company shall not be responsible for transportation or other costs other than those incurred within the provisions of Point 1 of this Certificate.
6. These warranties shall not apply to the appliance if it is purchased or used beyond the borders of the Republic of South Africa, Namibia, Botswana, Swaziland and Lesotho.
7. Where service is requested under warranty and no fault or defect can be found by the Company, all costs incurred will be for the purchaser's account.
8. This Certificate as well as your invoice will serve as proof of purchase. For the purpose of warranty, it will be essential to produce this Certificate and invoice. Failure to do so, will render the purchaser liable for service costs.

**KEEP THIS CERTIFICATE AND SALES INVOICE AS PROOF OF
PURCHASE FOR WARRANTY PURPOSES.**



You can rely on Defy. To simplify.

The Manufacturer strives for continuous improvements. For this reason, the text and illustrations in this book are subject to change without notice.

Part Number 14875