

TEC

TEC Color Printer

CB-416-T3-QQ

Owner's Manual

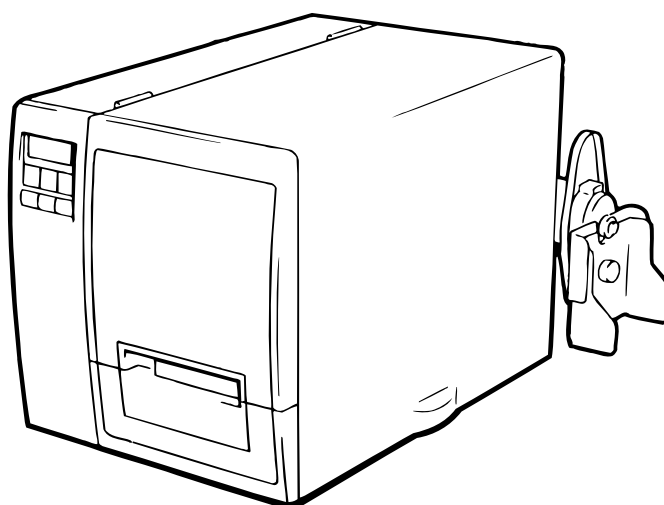

TOSHIBA TEC CORPORATION

We, TOSHIBA TEC Corporation of 570 Ohito Ohito-cho Tagata-Gun Shizuoka-Ken 410-2323 JAPAN, declare in our sole responsibility that this product has been tested and found to comply with the limits for a Class A digital device, pursuant to Part 15 of the FCC Rules. These limits are designed to provide reasonable protection against harmful interference when the equipment is operated in a commercial environment. This accordance with the instruction manual, may cause harmful interference to radio communications. Operations of this equipment in a residential area is likely to cause harmful interference in which case the user will be required to correct the interference at his own expense.
(for USA only)

Changes or modifications not expressly approved by manufacturer for compliance could void the user's authority to operate the equipment.

“This Class A digital apparatus meets all requirements of the Canadian Interference-Causing Equipment Regulations.”
“Cet appareil numérique de la classe A respecte toutes les exigences du Règlement sur le matériel brouilleur du Canada.”
(for CANADA only)

CAUTION:

- 1.This manual may not be copied in whole or in part without prior written permission of TOSHIBA TEC.
- 2.The contents of this manual may be changed without notification.
- 3.Please refer to your local Authorized Service representative with regard to any queries you may have in this manual.

Trademark:

- Microsoft, Windows, Windows NT, and the Windows Logo are either registered trademarks or trademarks of Microsoft Corporation in the United States.
- All other brands and names are the property of their respective owners.

Safety Precautions

Safety Summary

Personal safety in handling or maintaining the equipment is extremely important. Warnings and Cautions necessary for safe handling are included in this manual. All warnings and cautions contained in this manual should be read and understood before handling or maintaining the equipment.

Do not attempt to effect repairs or modifications to this equipment. If a fault occurs that cannot be rectified using the procedures described in this manual, turn off the power, unplug the machine, then contact your authorized TOSHIBA TEC representative for assistance.

Meanings of Symbols



This symbol indicates warning items (including cautions). Specific warning contents are drawn inside the \triangle symbol. (The symbol on the left indicates a general caution.)



This symbol indicates prohibited actions (prohibited items). Specific prohibited contents are drawn inside or near the \odot symbol. (The symbol on the left indicates “no disassembling”.)



This symbol indicates actions which must be performed. Specific instructions are drawn inside or near the \bullet symbol. (The symbol on the left indicates “disconnect the power cord plug from the outlet”.)

⚠ WARNING This indicates that there is the risk of death or serious injury if the machines are improperly handled contrary to this indication.



Any other than the specified AC voltage is prohibited.

- Do not use voltages other than the voltage (AC) specified on the rating plate, as this may cause **fire** or **electric shock**.

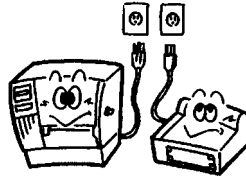

- If the machines share the same outlet with any other electrical appliances which consume large amounts of power, the voltage will fluctuate widely each time these appliances operate. Be sure to provide an exclusive outlet for the machine as this may cause the machines to **malfunction**.

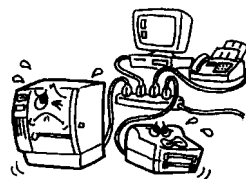

Prohibited

- Do not insert or drop metal, flammable or other foreign objects into the machines through the ventilation slits, as this may cause **fire** or **electric shock**.

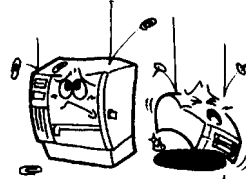

Prohibited

- If the machines are dropped or their cabinets damaged, first turn off the power switches and disconnect the power cord plugs from the outlet, and then contact your authorized TOSHIBA TEC representative for assistance. Continued use of the machine in that condition may cause **fire** or **electric shock**.

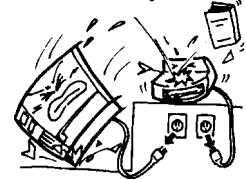

Disconnect the plug.

- Do not plug in or unplug the power cord plug with wet hands as this may cause **electric shock**.

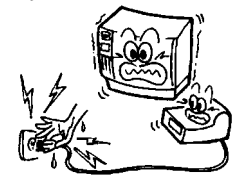

Prohibited

- Do not place metal objects or water-filled containers such as flower vases, flower pots or mugs, etc. on top of the machines. If metal objects or spilled liquid enter the machines, this may cause **fire** or **electric shock**.

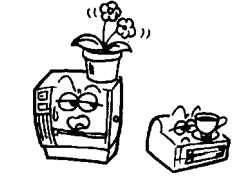

Prohibited

⚠ WARNING (Cont.)



Prohibited

- Do not cut, damage or modify the power cords. Also, do not place heavy objects on, pull on, or excessively bend the cords, as this may cause **fire** or **electrical shock**.

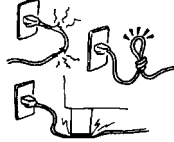

Disconnect the plug.

- Continued use of the machines in an abnormal condition such as when the machines are producing smoke or strange smells may cause **fire** or **electric shock**. In these cases, immediately turn off the power switches and disconnect the power cord plugs from the outlet. Then, contact your authorized TOSHIBA TEC representative for assistance.



Disconnect the plug.

- If foreign objects (metal fragments, water, liquids) enter the machines, first turn off the power switches and disconnect the power cord plugs from the outlet, and then contact your authorized TOSHIBA TEC representative for assistance. Continued use of the machine in that condition may cause **fire** or **electric shock**.

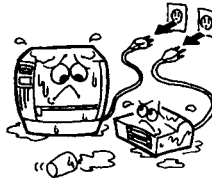

Connect a grounding wire.

- Ensure that the equipment is properly grounded. Extension cables should also be grounded. **Fire** or **electric shock** could occur on improperly grounded equipment.

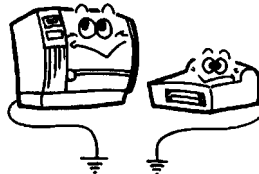

Disconnect the plug.

- When unplugging the power cords, be sure to hold and pull on the plug portion. Pulling on the cord portion may cut or expose the internal wires and cause **fire** or **electric shock**.

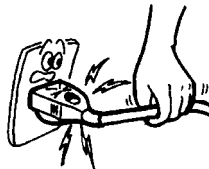

No disassembling.

- Do not remove covers, repair or modify the machine by yourself. You may be **injured** by high voltage, very hot parts or sharp edges inside the machine.

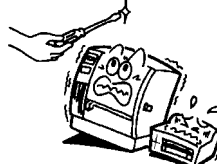

⚠ CAUTION

This indicates that there is the risk of personal injury or damage to objects if the machine is improperly handled contrary to this indication.

The following precautions will help to ensure that this machine will continue to function correctly.

- Try to avoid locations that have the following adverse conditions:
 - * Temperatures out of the specification
 - * Direct sunlight
 - * Shared power source
 - * Dust/Gas
 - * High humidity
 - * Excessive vibration
 - The cover should be cleaned by wiping with a dry cloth or a cloth slightly dampened with a mild detergent solution. NEVER USE THINNER OR ANY OTHER VOLATILE SOLVENT on the plastic covers.
 - USE ONLY TOSHIBA TEC SPECIFIED paper and ribbons.
 - DO NOT STORE the paper or ribbons where they might be exposed to direct sunlight, high temperatures, high humidity, dust, or gas.
 - Ensure the printer is operated on a level surface.
 - Any data stored in the memory of the printer could be lost during a printer fault.
 - Try to avoid using this equipment on the same power source as high voltage equipment or equipment likely to cause electrical interference.
 - Unplug the machine whenever cleaning or working inside it.
 - Keep the work environment static free.
 - Do not place heavy objects on top of the machines, as these items may become unbalanced and fall causing **injury**.
 - Do not block the ventilation slits of the machines, as this will cause heat to build up inside the machines and may cause **fire**.
 - Do not lean against the machine. It may fall and cause **injury**.
 - Care must be taken not to injure yourself with the printer paper cutter.
 - Unplug the machine when it is not used for a long period of time.
- Request Regarding Maintenance**
- Utilize our maintenance services.
After purchasing the machine, contact your authorized TOSHIBA TEC representative for assistance once a year to have the inside of the machine cleaned. Otherwise, dust will build up inside the machines and may cause a **fire** or a **malfunction**. Cleaning is particularly effective before humid rainy seasons.
 - Our preventive maintenance service performs the periodic checks and other work required to maintain the quality and performance of the machines, preventing accidents beforehand.
For details, please consult your authorized TOSHIBA TEC representative for assistance.
 - Do not expose the machines to insecticides or other volatile solvents. This will cause the cabinet or other parts to deteriorate or cause the paint to peel.

Table of Contents

1. Product Overview	1
1.1 Introduction	1
1.2 Features	1
1.3 Unpacking	1
1.4 Accessories and Options	2
1.4.1 Accessories	2
1.4.2 Cool Release Enhancement Kit	3
1.4.3 Options	3
1.5 Appearance	4
1.5.1 Dimensions	4
1.5.2 Front View	4
1.5.3 Rear View	4
1.5.4 Operation Panel	5
1.5.5 Interior	5
2. Printer Installation	6
2.1 Installing the Accessories	6
2.1.1 Fan Filters	6
2.1.2 Media Slide	6
2.1.3 Supply Shaft Holder	6
2.2 Connecting the Printer to Your Computer	7
2.3 Connecting the Power Cord	8
2.4 Turning on/off the Printer	9
2.4.1 Turning on the Printer	9
2.4.2 Turning off the Printer	10
2.5 Loading the Media	11
2.5.1 Additional Information	16
2.6 Sensor Adjustments	17
2.6.1 Black Mark Sensor	17
2.6.2 Feed Gap Sensor	18
2.6.3 Media Sensor Sensitivity Adjustment	19
2.7 Loading the Ribbons (for Hot Release Ribbons)	21
2.7.1 Ribbon Positions	21
2.7.2 Loading Procedure	21
2.8 Loading the Ribbons (for Cold Release Ribbons)	24
2.8.1 Precautions	24
2.8.2 Installing the Ribbon Plate	25
2.8.3 Installing the SP Ribbon Guides	26
2.8.4 Installing the Ribbon Tension Sheet	27
2.8.5 Loading the Cold Release Ribbons	28
3. Printing	29
3.1 Installing the Printer Driver	29
3.1.1 System Requirements	29
3.1.2 Installation Procedure (For Windows®98)	29
3.1.3 Uninstalling the Printer Driver	35
3.2 Properties	37
3.2.1 Displaying Printer Properties	37
3.2.2 Summary of Properties	38
3.3 Page Setup	39
3.3.1 Selecting a label size	39
3.3.2 Creating a new label size	40
3.3.3 Orientation	41
3.3.4 Miscellaneous	42
3.4 Graphics	46
3.4.1 Dithering	46
3.4.2 Intensity	47
3.4.3 Color	47
3.4.4 Color Registration	47
3.4.5 Spot Color Setup	49
3.4.6 Spot Color Printing	50
3.5 Bar Fonts	51
3.5.1 Specifying a New Font Style	52

3.6 Stock	54
3.6.1 Print Method	54
3.6.2 Sensor	54
3.6.3 Label Gap	54
3.6.4 Issue Settings	55
3.6.5 Fine Adjustment	56
3.7 Options	57
3.7.1 Transfer Mode	57
3.7.2 Print Density Adjustment	57
3.8 Device Settings	58
3.8.1 Maintenance	59
3.8.2 Testing	59
3.9 Print Test	60
3.9.1 Procedures	60
3.10 Printing a Label	61
4. Online Mode	64
4.1 Operation Panel	64
4.2 Operation	65
4.3 Reset	65
5. Maintenance	66
5.1 Cleaning	66
5.1.1 Print Head/Platen	66
5.1.2 Pinch Roller/Feed Roller/Media Guide	67
5.1.3 Fan Filters	67
5.1.4 Covers and Panels	68
5.1.5 Ribbon Modules	68
6. Troubleshooting	69
6.1 Error Messages	69
6.2 Possible Problems	71
6.3 Removing Jammed Media	72
6.3.1 From the Pinch Roller Unit	72
6.3.2 From the Print Head Block	72
6.4 When the Ribbon is Torn Apart	73
Appendix 1 Specifications	74
A1.1 Printer	74
A1.2 Options	75
A1.3 Media	75
A1.3.1 Media Type	75
A1.3.2 Detection Area of the Transmissive Sensor	76
A1.3.3 Detection Area of the Reflective Sensor	77
A1.3.4 Effective Print Area	77
A1.4 Ribbon	78
Appendix 2 DIP Switches	79
A2.1 DIP Switch A	80
A2.2 DIP Switch B	81
A2.3 Ribbon Near End Detection	82
Appendix 3 Quick Reference for Printing	83
Appendix 4 Message and LED	86
Appendix 5 System Mode	88
A5.1 Operation Panel	88
A5.2 Overview	89
A5.3 Self-Diagnostic Test	91
A5.4 Parameter Setting	92
A5.5 Test Print	101
A5.6 RAM Clear	104
A5.7 Additional Information	106
A5.7.1 Self-Diagnostic Test Result Sample and Descriptions	106
A5.7.2 Maintenance Counter/Parameter Check Print Sample and Descriptions	107
A5.7.3 Cut Operation Example	108
A5.7.4 Pulse Motor Speed	108
A5.7.5 X-Coordinate Fine Adjustment	108
A5.7.6 Magnified Views of Slant Line Pattern	108
A5.7.7 Initial Values after Clearing the Maintenance Counter (MAINTE.CNT.CLEAR)	109
A5.7.8 Initial Values after Clearing the Parameter (PARAMETER CLEAR)	110
A5.7.9 Initial Values after Clearing the Print Distance (PRINT STEP CLEAR)	111
Appendix 6 Interface	112

1. Product Overview

1.1 Introduction

Thank you for choosing the TOSHIBA TEC CB-416-T3 color printer. This Owner's Manual describes printer setup and installation procedures, printer properties, settings and adjustments, and maintenance information. Thus it should be read carefully to help gain maximum performance and life from the printer. For further information please refer to this manual and keep it safe for future reference.

1.2 Features

The CB-416-T3 color printer has the following features:

- High-speed, quality printing. The printer utilizes Edge Heads that support the high-performance Hot Release Ribbons to produce a maximum print speed of approximately 6 in/s (150 mm/s). In addition, the Cool Release Enhancement Kit is supplied as an accessory, and allows the popular Cold Release Ribbons to be loaded.
- Fine, sharp color printing. The printer utilizes four high-resolution (305 dpi) print heads, and uses both basic process color ribbons of yellow, cyan, magenta and black to produce up to 260,000 colors, and a variety of spot color ribbons for solid printing.
- A variety of printer fonts and bar code fonts are built into the printer to help create a unique colored label.
- Cost efficiency. The automatic ribbon saver is standard and allows for conservation of individual ribbons. In addition, the media back feed capability allows you to avoid wasting the media.

1.3 Unpacking

Unpack the printer as per the Unpacking Instructions packed with the printer.

Important!

- *Check for damage or scratches on the printer. However, please note that TOSHIBA TEC shall have no liability of any damage of any kind sustained during transportation of the product.*
- *Keep the cartons and pads for future transportation of the printer.*

1.4 Accessories and Options

When unpacking the printer, please make sure all accessories are packed with the printer.

1.4.1 Accessories

Owner's Manual (1 pc.)

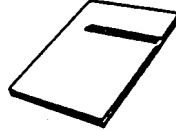

Power Cord (1 pc.)
(FBC B0030202)

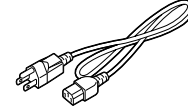

Thermal Head Cleaner (1 pc.)
(24089500013)



Feed Roller Brush (1 pc.)
(FMQB0047001)

*To be used exclusively for the Feed Roller

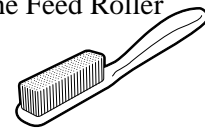

Fan Filter (2 sets.)
(FMBB0046401)

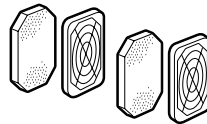

Media Slide (1 pc.)
(FMCC 0032001)

Black Screw (2 pcs.)
(HAA-0007002)

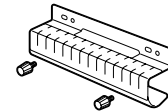

Supply Shaft Holder (1 pc.)
(FMBD 0038901)

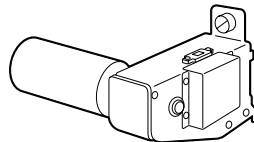

Supply Shaft Holder Stand (1pc.)
(FMBB0047401)

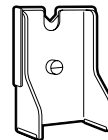

Supply Roll Holder (2 pcs.)
(FMHD0007502)

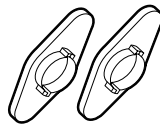

Unpacking Instructions (1 pc.)

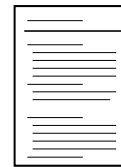

Ferrite Core (1 pc.)
(HGA-0068001)

*Used for RS-232C

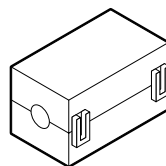

Color Print Sample (1 pc.)

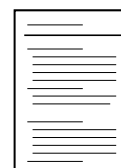

1.4.2 Cool Release Enhancement Kit

Ribbon Plate (4 pcs.)
(FMCB 0095301)

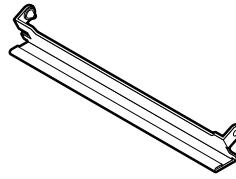

Mounting Screw (4 pcs.)
(FMDB 0079501)



D-3x5 Screw (12 pcs.)
(X0140305130)



SP Ribbon Guide (A) (1 pc.)
(FMCB0095601)

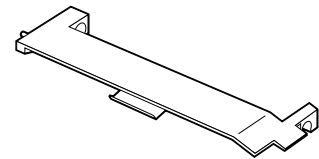

SP Ribbon Guide (B) (3 pcs.)
(FMCB0095501)

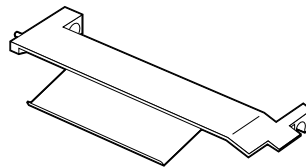

Ribbon Tension Sheet (4 pcs.)
(FMQC0035901)

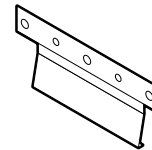

Sheet Fixing Plate (4 pcs.)
(FMEB0116901)

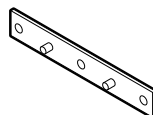

1.4.3 Options

The following two options are available for the CB-416-T3 color printer:

- The CB-1204-QM Cutter Module, which is used to cut media repeatedly.
- The CB-1004-QM Ribbon Module, to be used as a spare ribbon module.

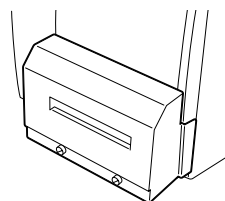

Cutter Module

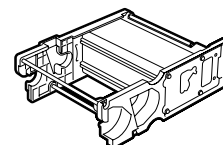

Ribbon Module

1.5 Appearance

The names of the parts or units introduced in this section are used in the following chapters.

1.5.1 Dimensions

Note:
Depth is 34.4 inches (875mm) when the Cutter Module is installed on the printer.

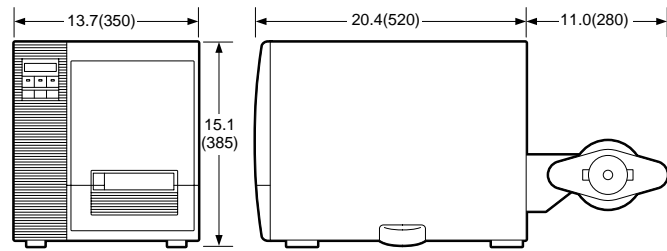

Dimensions in inches + (mm)

1.5.2 Front View

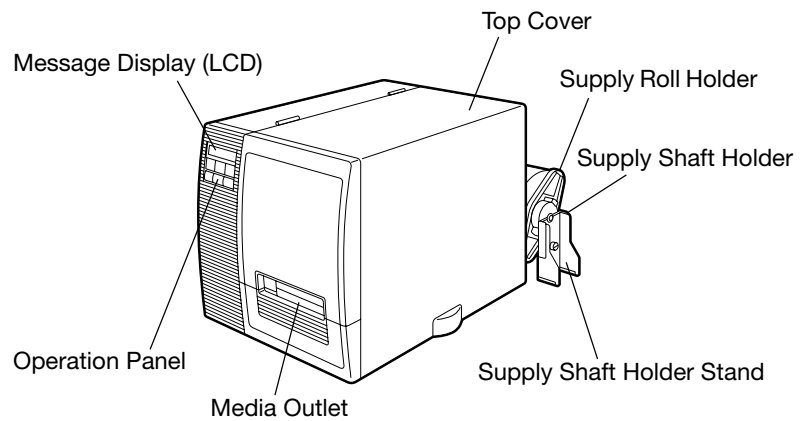

1.5.3 Rear View

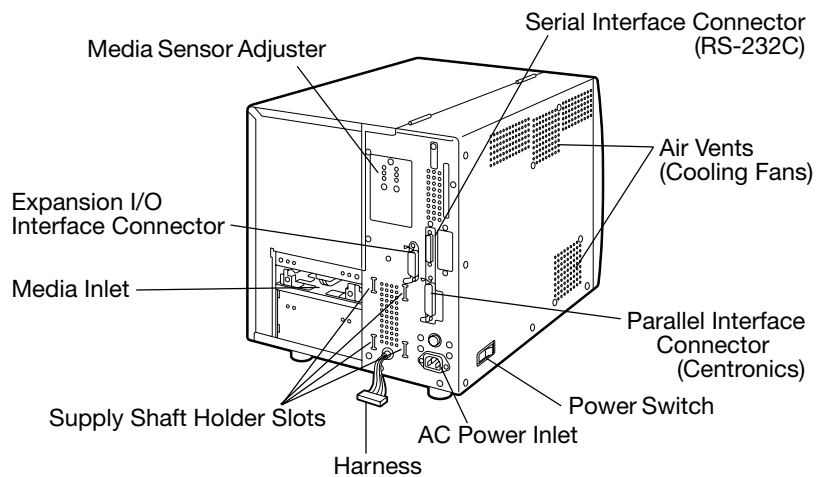

1.5.4 Operation Panel

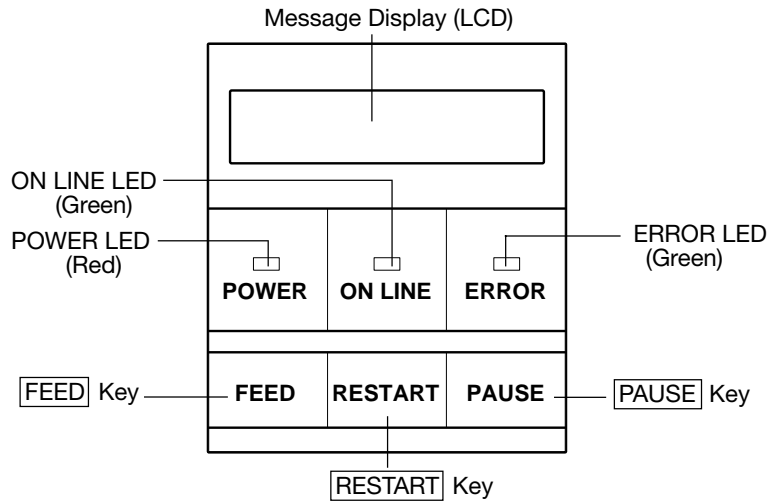

Please see *Appendix 3* for further information about the Operation Panel.

1.5.5 Interior

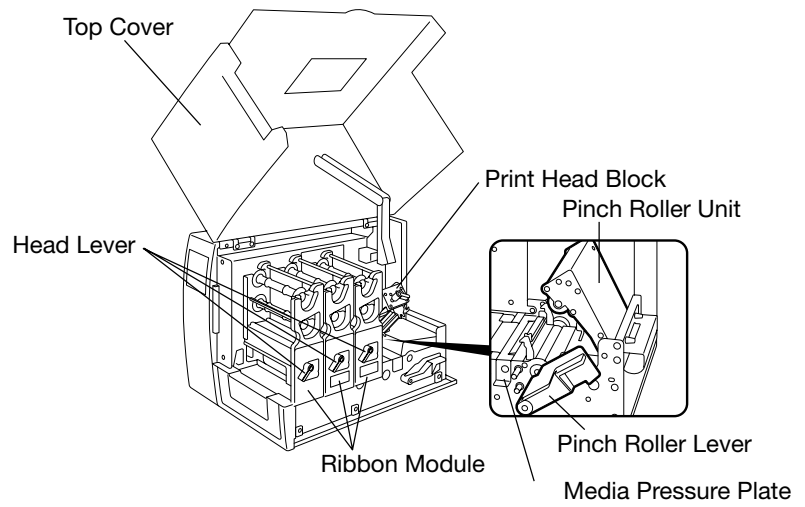

2. Printer Installation

This chapter describes in detail how to set up the printer to get ready for printing.

2.1 Installing the Accessories

2.1.1 Fan Filters

First install the accessories on the printer.

- 1 Unpack the Fan Filters.
- 2 Mount the Fan Filters over the Air Vents.

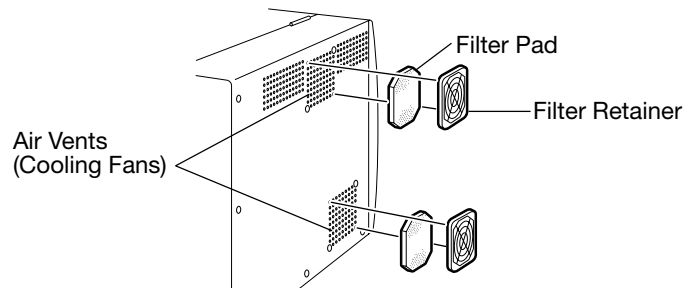

Note:
Please clean the Filter Pads periodically. See Section 5.1.3.

2.1.2 Media Slide

Notes:

- Either a roll of labels or tags can be loaded in the printer.
- In this Owner's Manual, labels and tags are generically called "media".
- TOSHIBA TEC recommends that labels are rolled outside, and the tags are rolled inside. The media loading procedure depends on which type of media is going to be loaded. See Section 2.5 for more detail.

Attach the Media Slide with the two supplied black screws.

When loading a roll of labels, fit the Media Slide on the screw holes above the Media Inlet.

or

When loading a roll of tags, fit the Media Slide on the screw holes below the Media Inlet.

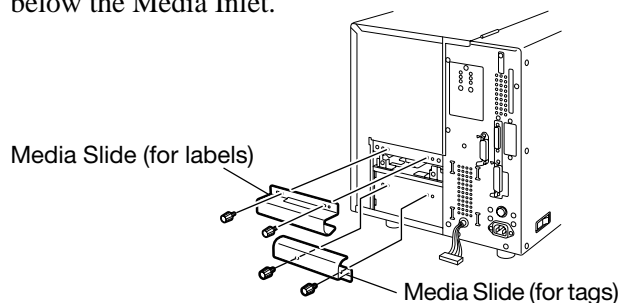

2.1.3 Supply Shaft Holder

- 1 Connect the Supply Shaft Holder Harness to the harness attached on the rear of the printer.
- 2 First hook the lower parts of the Supply Shaft Holder into the lower two Supply Shaft Holder Slots on the rear of the printer. Then fix the Supply Shaft Holder in place by tightening the screw.

To remove the Supply Shaft Holder from the printer, just reverse the installation procedure.

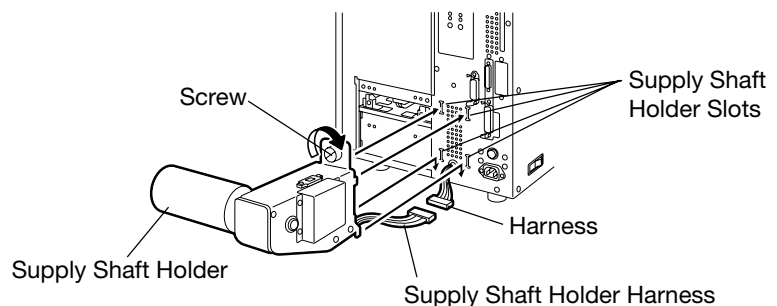

2.2 Connecting the Printer to Your Computer

Note:
The interface cable is not included in the accessories.

The printer can be connected to any computer, since it supports both serial and parallel interface cables. Before connecting the printer, please make sure which interface cable will be used.

- 1 Be sure that both printer and computer are turned off. (○ indicates OFF).

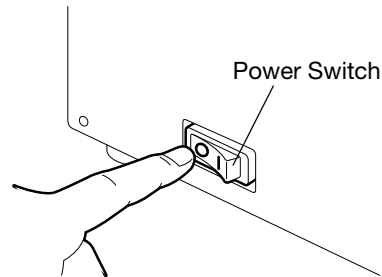

- 2 Connect the interface cable to the interface connector on the printer. As illustrated below, connect the interface cable to either of the interface connectors, depending on which interface cable will be used.

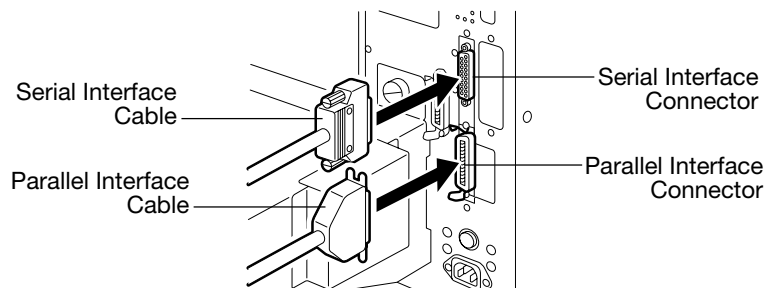

- 3 Secure the cable with the clamps or screws.
- 4 When using the serial interface cable, attach the supplied ferrite core to the cable.
- 5 Connect the interface cable to the interface connector on the computer.

Note:
Please refer to the user's manual of the computer.

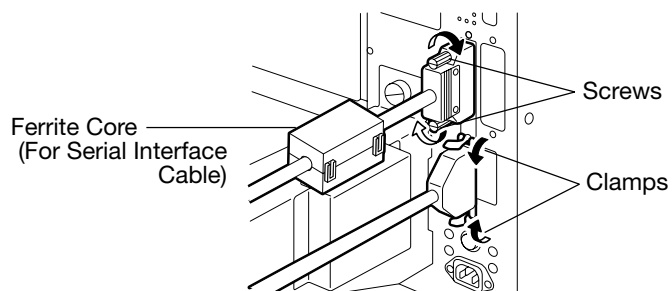

2.3 Connecting the Power Cord

CAUTION!

- Please turn off the printer before connecting the power cord, as this may cause an electric shock or damage to the printer.
- Please use the supplied power cord only. Use of other cords may cause an electric shock or a fire.

- 1 Be sure that both printer and computer are switched OFF. (○) indicates OFF.

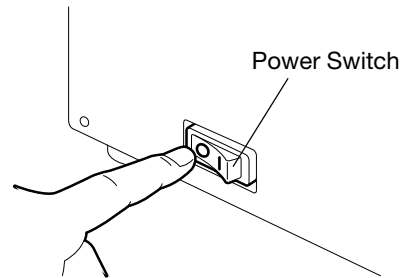

- 2 Connect the supplied power cord to the AC Power Inlet of the printer.

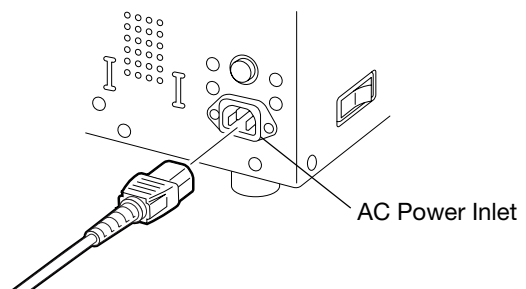

- 3 Plug the power cord in an outlet.

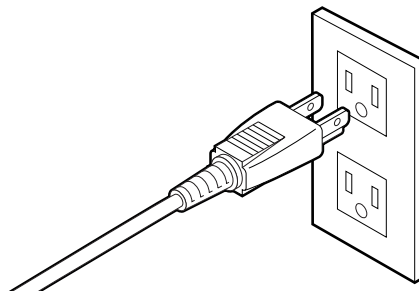

2.4 Turning on/off the Printer

When turned on, the printer checks the print head and memory.
When turned off, the printer will lose data in non-volatile memory.

CAUTION!

Use the power switch to turn on/off the printer. Unplugging the power cord for turning on/off the printer may cause a fire, an electric shock, or damage to the printer.

Important!

When the printer is connected to the computer,

- *Turn ON the printer before turning on the computer.*
- *Turn OFF the computer before turning off the printer.*

2.4.1 Turning on the Printer

- 1 Turn on the printer. (I) indicates ON.

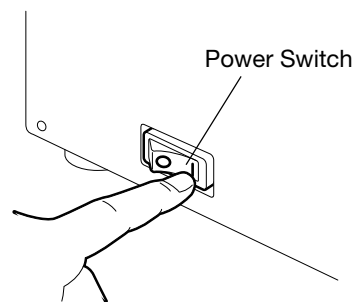

- 2 The “ON LINE” message appears on the Message Display. The POWER LED illuminates green. Then the ON LINE LED also illuminates green.

Note:
Just in case the printer is not turned on, or any error message appears, please see Chapter 6.

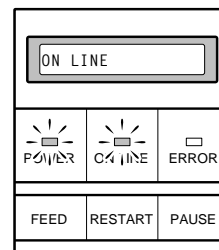

2.4.2 Turning off the Printer

CAUTION!

- *Do not turn off the printer while a label is being issued, as this may cause a paper jam or damage to the printer.*
- *Do not turn off the printer when the ON LINE LED is blinking, as this may cause damage to the computer connected to the printer.*

- 1 When turning off the printer, make sure of the following:
 - The “ON LINE” message is shown on the Message Display.
 - Both POWER and ON LINE LED’s are illuminated.

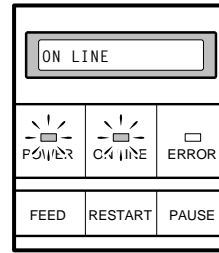

- 2 Turn off the power switch.

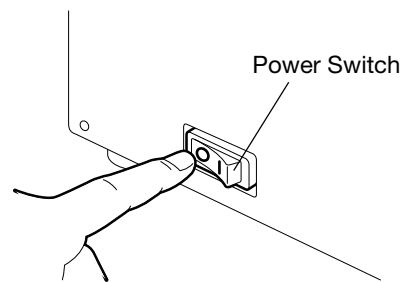

2.5 Loading the Media

Labels or tags can be loaded in the printer. The media loading procedure depends on which media is going to be used.

- 1 Open the Top Cover.

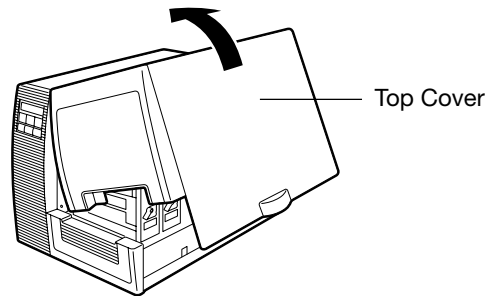

- 2 Lift the Pinch Roller Lever to the ROLLER RELEASE position to open the Pinch Roller Unit.

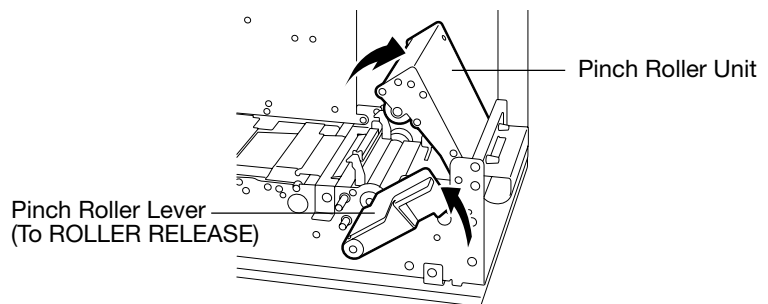

- 3 Loosen the screw on the Supply Shaft Holder Stand.

- 4 Fit the Supply Shaft Holder Stand to the Supply Shaft, as illustrated below. The Supply Shaft Holder Stand moves up or down so that the Supply Shaft is kept level.

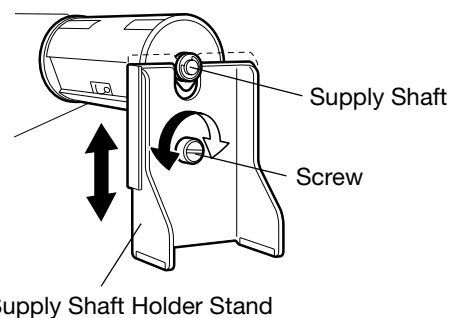

- 5 Remove the Supply Shaft Holder Stand from the Supply Shaft, when adjustment to its height is complete.

Note:
 The Supply Shaft cannot be kept level because of its weight, as the printer becomes older. So before loading the media, adjust the Supply Shaft so that it can be kept level.

2.5 Loading the Media (Cont.)

- 6 Turn the Supply Shaft so that the notches face upward, and the marks face the Media Inlet.
- 7 To attach the Supply Roll Holder (inside), fit the tooth of the Supply Roll Holder to the groove of the Supply Roll Shaft. Turn the Supply Roll Holder clockwise to the end.

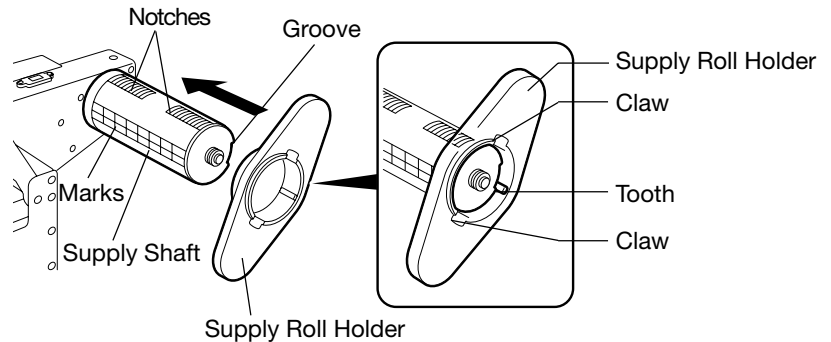

CAUTION!

Do not push into the Supply Roll Holder (inside) with the claw locked in the notches, as this may cause damage to the claw or notches. See Section 2.5.1 for more detail.

- 8 Push the Supply Roll Holder (inside) to the end of the Supply Shaft. Then turn the Supply Roll Holder counterclockwise so that the claw is locked into the notch. When inserting the Supply Roll Holder into the Supply Shaft, more pressure should be applied when passing over the roller on the way to the end of the Supply Shaft.

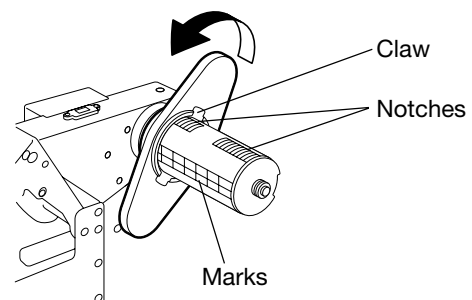

Note:

The media is rolled either outside or inside, depending on the type of media that is loaded. Whichever media is used, load it with print side facing up. See Appendix 1 for more detail.

- 9 Switch the Back Tension Selector, depending on whether the media is rolled outside or inside. Switch the Selector to A for the media rolled outside. Switch it to B for the media rolled inside, as indicated by the arrows.

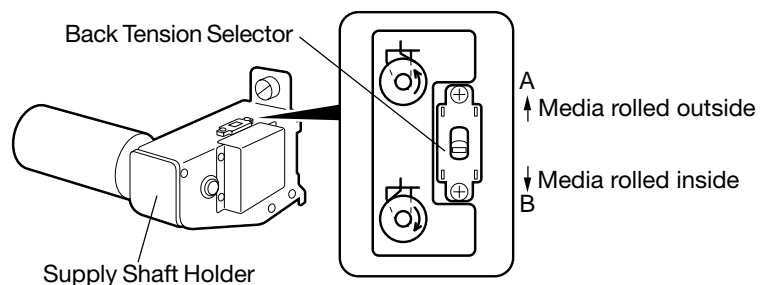

- 10 Measure width of the media that will be loaded.

2.5 Loading the Media (Cont.)

Note:

When inserting a roll of labels or tags, push on the media core only. Otherwise, core material drags against the Supply Shaft causing telescoping of the media supply roll.

- 11 Based on width of the media measured in Step 10, push the media into the Supply Roll Holder (inside), and place it with reference to the marks on the Supply Shaft.

- Loading a roll of labels

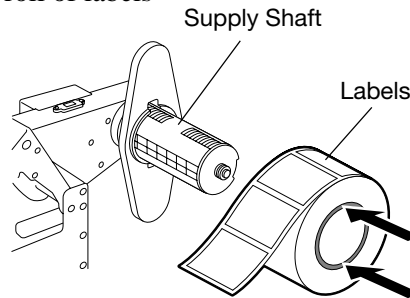

- Loading a roll of tags

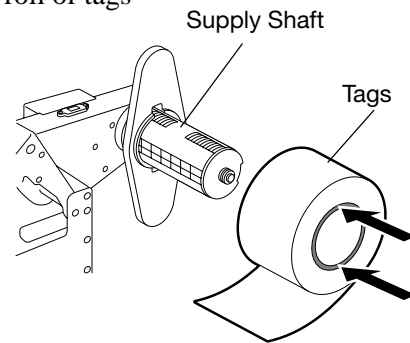

- 12 Slide the Supply Roll Holder (inside) to the loaded media.

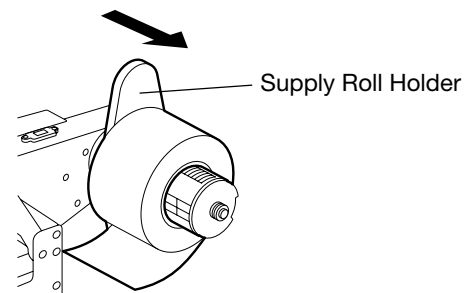

CAUTION!

To remove the Supply Roll Holder (outside), turn it to disengage the claw from the notches. Otherwise, the claw or the notches may be damaged. See Section 2.5.1 for more detail.

- 13 Slide the Supply Roll Holder (outside) to the loaded media.

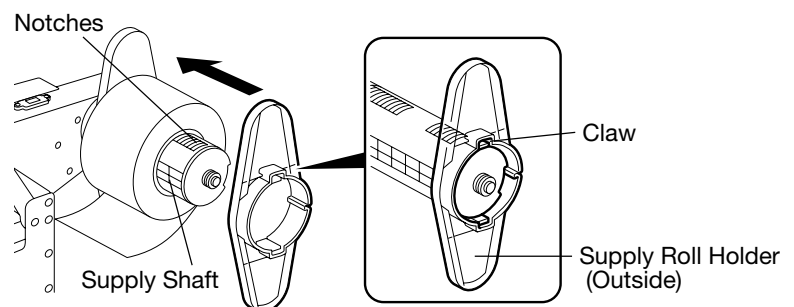

2.5 Loading the Media (Cont.)

- 14 Loosen the two screws. Slide the Media Guides in the direction of the arrows below until they stop (completely open).

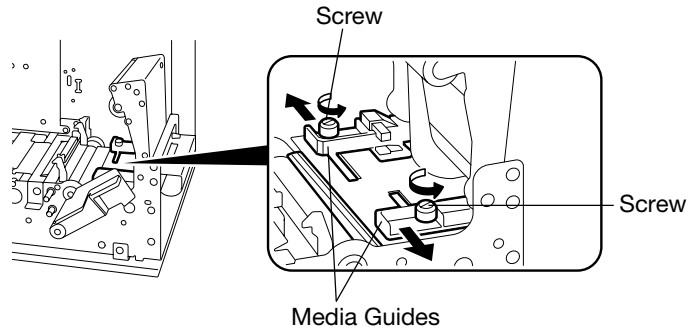

- 15 Unroll about 1.5 to 2 inches (40 to 50cm) of the media.

- 16 Insert the media into the Media Inlet. Make sure that the media passes under the Media End Sensor, the media sensor and the Media Pressure Plate.

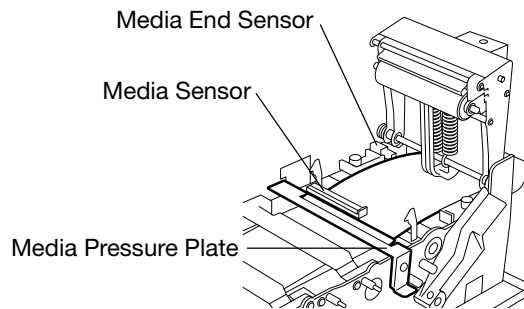

Note:
 Make sure that the leading edge of media is cut straight before inserting the media into the printer, as this may cause a media jam.



Right



Wrong

Important!

- According to the media is loaded, adjust the position of the media sensor. See Section 2.6 for more detail.
- Whenever the type of media is changed, adjust sensitivity of the media sensor. See Section 2.7 for more detail.

CAUTION!

Do not over tighten the two screws, as this may cause damage to the Media Guides.

- 17 Slide the Media Guides in the direction of the arrows below until both guides come in contact with the media (media should be in center of media path). Hand tighten the two screws.

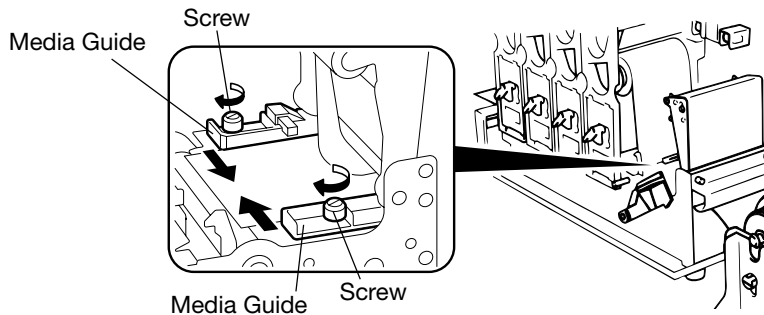

2.5 Loading the Media (Cont.)

Notes:

- Pass the media straight from the Supply Holder Unit to the Media Outlet to avoid skewing.
- Use the marks at the Media Slide and the Media Outlet so that the media can be centered.
- Be sure to take up any slack in the media.

- 18 Feed the media to the Media Outlet manually until its leading edge comes out of the Media Outlet.
(Top View of the Printer)

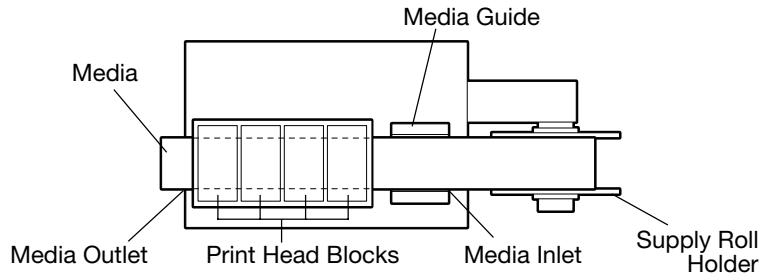

(Side View of the Printer)

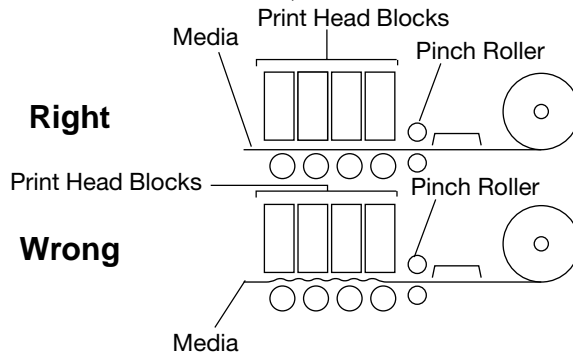

Note:
Push down the Pinch Roller Unit gently on the "PUSH HERE" label.

- 19 Push down the Pinch Roller Unit until it is hooked. Then push down the Pinch Roller Lever to the ROLLER LOCK position.
[PUSH HERE]

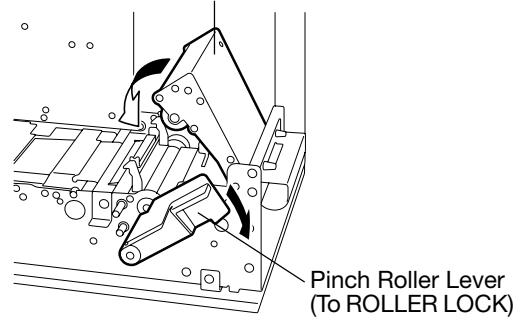

- 20 Reinstall the Supply Shaft Holder Stand to the Supply Shaft Holder, whose level is adjusted in Steps 3 to 5.

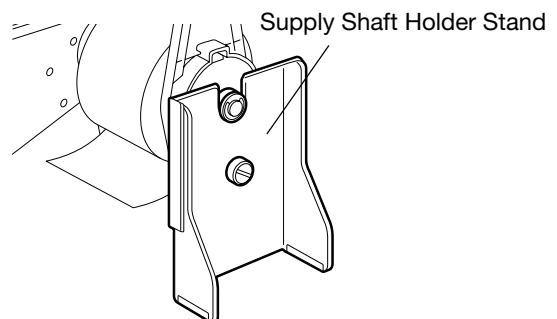

2.5 Loading the Media (Cont.)

Note:
When loading labels, make a straight cut in the gap area between labels.

- 21 Close the Top Cover gently. Make sure that the POWER LED and ON LINE LED are illuminated, and that the “ON LINE” message is shown. Press the **FEED** key on the Operation Panel to feed the media about 1 inch (20 to 30cm). Check that the media is fed successfully.

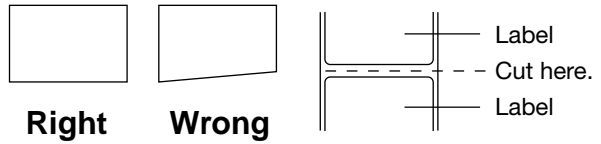

2.5.1 Additional Information

This section contains more information concerning the care that should be taken when loading the media.

- The figure below indicates the direction the Supply Roll Holder (inside) can be moved with the claws of the Supply Roll Holder locked into the notches.

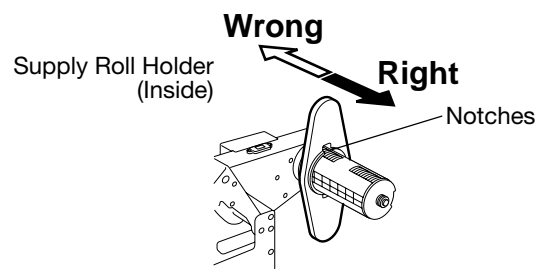

- The figure below indicates the direction the Supply Roll Holder (outside) can be moved with the claws of the Supply Roll Holder locked into the notches.

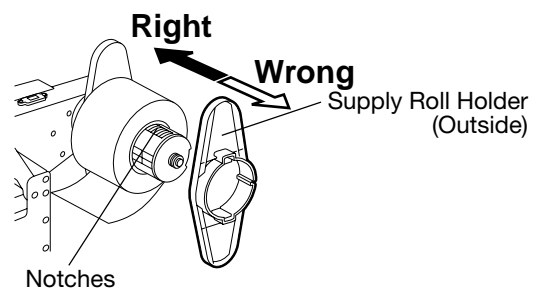

2.6 Sensor Adjustments

This section describes in detail how to adjust the media sensor positions and their sensitivity.

Whenever the type of media is changed, a positional adjustment of the media sensor is needed. The media sensors are designed to keep positional alignment of the image on each label or tag when issued.

Important!

NEVER skip the media sensor positional adjustment.

The printer has two types of media sensors: Black Mark Sensor and Feed Gap Sensor.

The Black Mark Sensor (reflective sensor) is used to detect black marks on the back of the media by the reflection of light. On the other hand, the Feed Gap Sensor (transmissive sensor) is used to detect gaps by the transmission of light.

Which media sensor to adjust depends on the type of media loaded.

2.6.1 Black Mark Sensor

When the media with black marks on the BACK is loaded, adjust the Black Mark Sensor (reflective sensor) position as follows:

- 1 Open the Top Cover.
- 2 Lift the Pinch Roller Lever to the ROLLER RELEASE position to open the Pinch Roller Unit.
- 3 Align the Media Guides to the width of the media.
- 4 Fold the media so that a black mark faces upward.
- 5 Insert the media into the Media Inlet.
- 6 Turn the Media Guide Knob, and move the media sensor so that it is positioned at the center of the black mark.

Note:
"1" marked on the sensor indicates the Black Mark Sensor position.

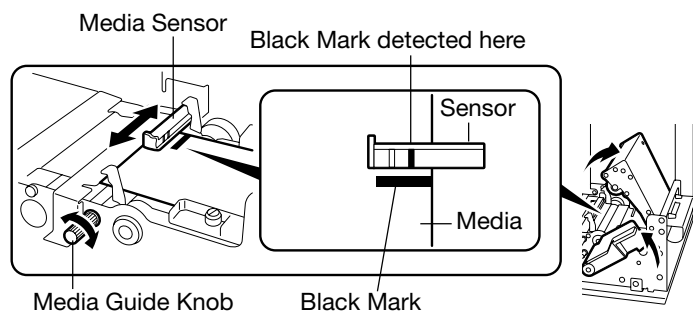

Note:
See A1.3.3 for black mark specifications.

- 7 The Black Mark Sensor Position Adjustment has been completed.

2.6.2 Feed Gap Sensor

When the media with gaps or rectangular holes is loaded, adjust the Feed Gap Sensor (transmissive sensor) position as follows:

- 1 Open the Top Cover.
- 2 Lift the Pinch Roller Lever to the ROLLER RELEASE position to open the Pinch Roller Unit.
- 3 Align the Media Guides to width of the media.
- 4 Insert the media into the Media Inlet.
 - If the media with gaps is loaded, go to Step 5.
 - If the media with rectangular holes is loaded, go to Step 6.
- 5 Turn the Media Guide Knob, and move the media sensor so that the gap between labels will pass under the sensor.

Note:
 "2" marked on the sensor indicates the Feed Gap Sensor position.

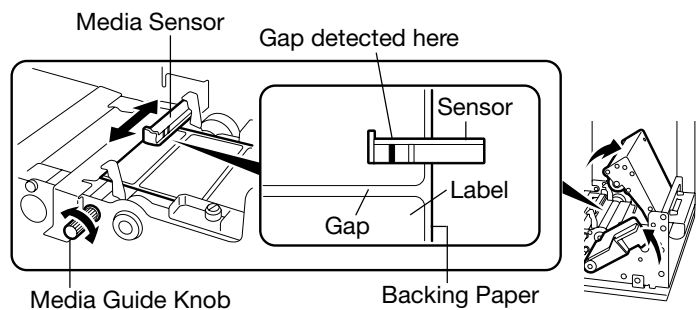

- 6 Turn the Media Guide Knob, and move the media sensor so that it is positioned at the center of the rectangular hole.

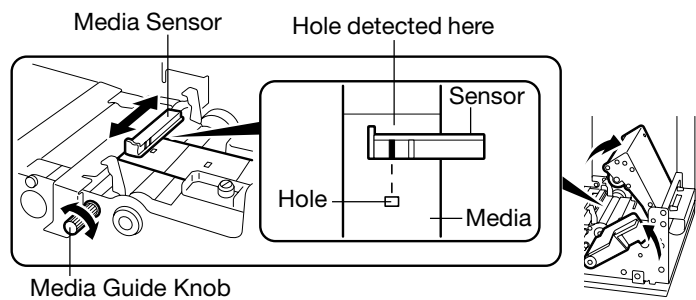

Note:
 See A1.3.2 for gap or hole specifications.

- 7 The Feed Gap Sensor Position Adjustment has been completed.

2.6.3 Media Sensor Sensitivity Adjustment

Whenever the type of media is changed, adjust the media sensor sensitivity.

Please note that the adjustment procedures are slightly different, depending on which type of media loaded.

Media Sensor Adjustor

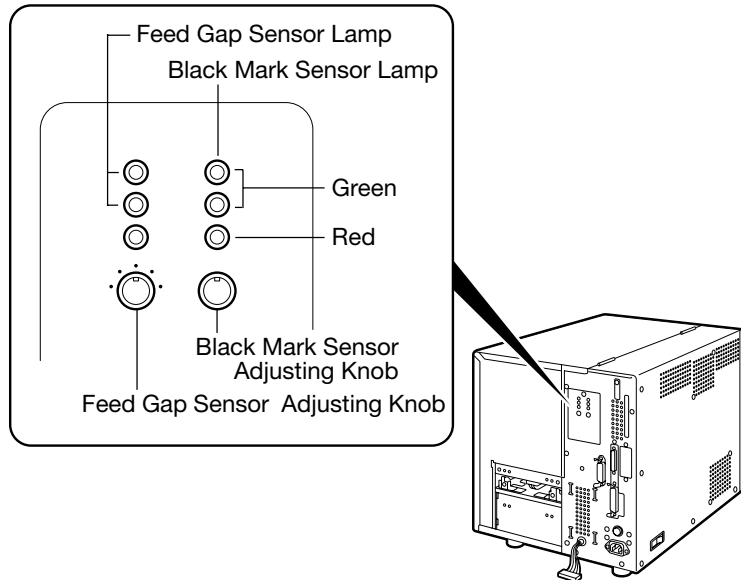

Black Mark Sensor Sensitivity Adjustment

- 1 Open the Top Cover.
- 2 Lift the Pinch Roller Lever to the ROLLER RELEASE position to open the Pinch Roller Unit.
- 3 Insert the media with black marks into the Media Inlet so that the Black Mark Sensor can detect the WHITE part of the media.
- 4 Lock the Pinch Roller Unit.
- 5 Turn on the printer.
- 6 Turn the Black Mark Sensor Adjusting Knob to the left most position.
- 7 Keep turning the knob clockwise slowly. When the upper two Black Mark Sensor Lamps illuminate green, the adjustment is complete.

Note:
As soon as the upper two lamps illuminate green, stop turning the knob.

2.6.3 Media Sensor Sensitivity Adjustment (Cont.)

Feed Gap Sensor Sensitivity Adjustment (for Label with Gaps)

- 1 Open the Top Cover.
- 2 Lift the Pinch Roller Lever to the ROLLER RELEASE position to open the Pinch Roller Unit.
- 3 Insert the label with gaps into the Media Inlet so that the Feed Gap Sensor can detect the LABEL part.
- 4 Lock the Pinch Roller Unit.
- 5 Turn on the printer.
- 6 Turn the Feed Gap Sensor Adjusting Knob to the left most position.
- 7 Keep turning the knob clockwise slowly. When the upper two Feed Gap Sensor Lamps illuminate green, the adjustment is complete.

Note:
As soon as the upper two lamps illuminate green, stop turning the knob.

Feed Gap Sensor Sensitivity Adjustment (for Media with Rectangular Holes)

- 1 Open the Top Cover.
- 2 Lift the Pinch Roller Lever to the ROLLER RELEASE position to open the Pinch Roller Unit.
- 3 Insert the media with rectangular holes into the Media Inlet so that the Feed Gap Sensor can detect the PAPER part.
- 4 Lock the Pinch Roller Unit.
- 5 Turn on the printer.
- 6 Turn the Feed Gap Sensor Adjusting Knob to the left most position.
- 7 Keep turning the knob clockwise slowly. When the upper two Feed Gap Sensor Lamps illuminate green, the adjustment is complete.

Note:
As soon as the upper two lamps illuminate green, stop turning the knob.

2.7 Loading the Ribbons (for Hot Release Ribbons)

Note:
Media Width does not include width of the backing paper.

This section describes in detail how to load all four ribbons in the printer.

Please use the ribbon width corresponding to the media width from the table shown below.

Ribbon Width	Media Width
2.7 (68)	2 to 2.6 (50 to 65)
3.5 (88)	2.6 to 3.4 (65 to 85)
4.3 (109)	3.4 to 4.4 (85 to 110)

Dimensions in inches + (mm)

There are two types of ribbons: high-performance Hot Release Ribbons that provide fast, quality print, and the popular Cold Release Ribbons. This section focuses on how to load the Hot Release Ribbons.

See Section 2.8 for loading procedures of the Cold Release Ribbons. Also refer to the table in Section 3.8.1 for specific information about each ribbon type. If the ribbon type to be used cannot be found in the table, contact an authorized sales representative.

2.7.1 Ribbon Positions

Note:
When using the spot color ribbons, load them as specified in the printer properties. See Sections 3.4.5 and 3.4.6 for more detail.

Please load the four ribbons in the correct positions, as illustrated below.

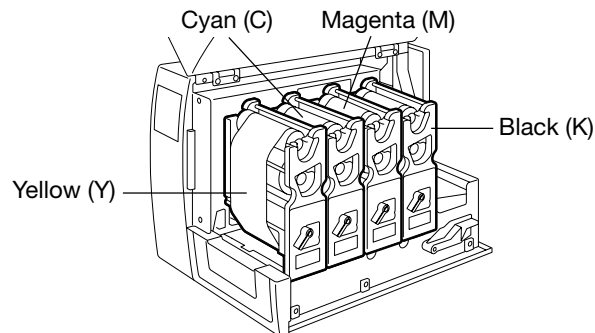

2.7.2 Loading Procedure

Notes:

- Turn the Head Lever to the OPEN position completely, or the Ribbon Module cannot be removed.
- Do not bend, drop, or give any shock to the Ribbon Module. Distortion of the Ribbon Module may cause poor print.

1 Open the Top Cover.

2 Turn the Head Lever to the OPEN position. Pull out each Ribbon Module in the direction of the arrow, and remove it from the printer.

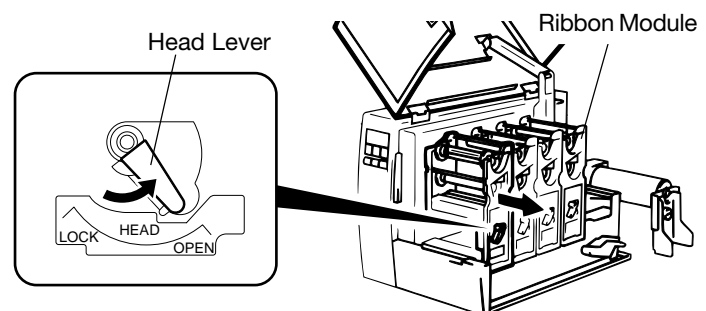

3 Remove the two Ribbon Shafts from the Ribbon Module. Remove the Ribbon Stopper from each Ribbon Shaft.

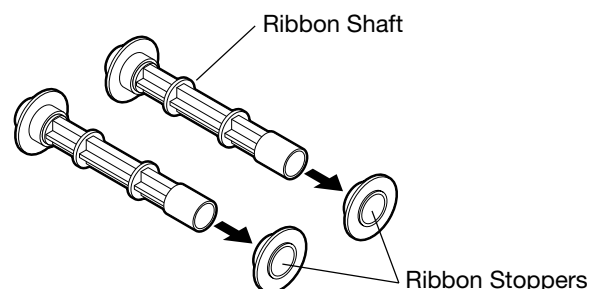

2.7.2 Loading Procedure (Cont.)

- 4 Insert the Ribbon Shaft into the Ribbon Winding Core. Fit the protrusion of the Ribbon Shaft into the notch of the Ribbon Winding Core. Insert the other Ribbon Shaft into the Ribbon Feed Core in the same manner.

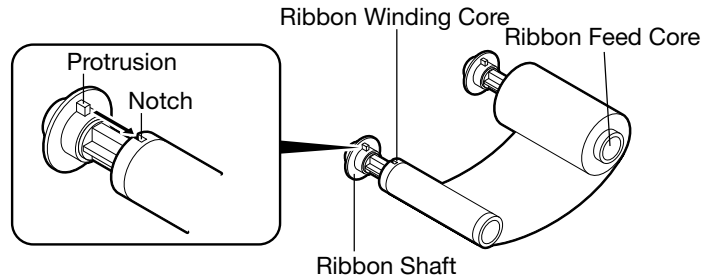

- 5 Attach the Ribbon Stoppers gently to each Ribbon Shaft.

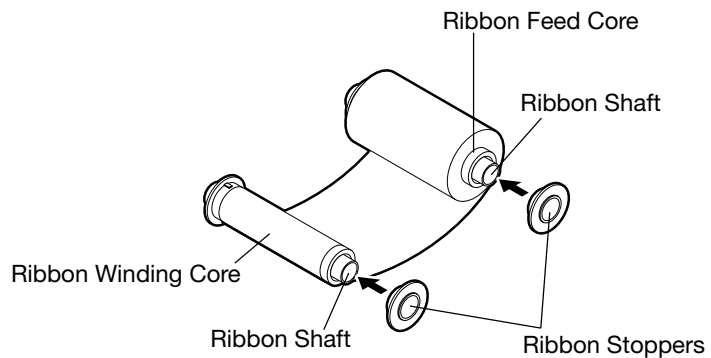

CAUTION!
Push in the Ribbon Stoppers gently. Otherwise, damage may occur.

Note:
Please make sure that the Ribbon Stoppers are completely inserted into the Ribbon Winding Core and Ribbon Feed Core respectively.

- 6 Unroll about 1 inch (30cm) of the ribbon. Place the Ribbon Module on the ribbon.

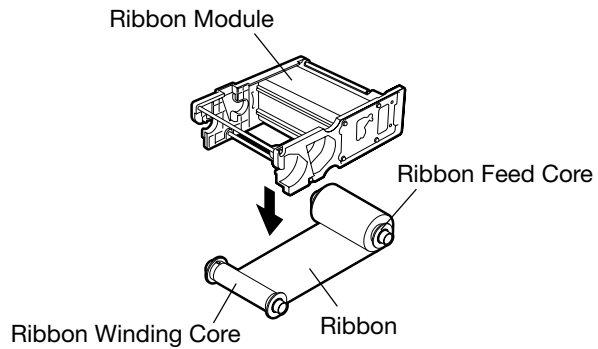

- 7 Insert the Ribbon Feed Core, and then the Ribbon Winding Core on the Ribbon Module, as illustrated below.

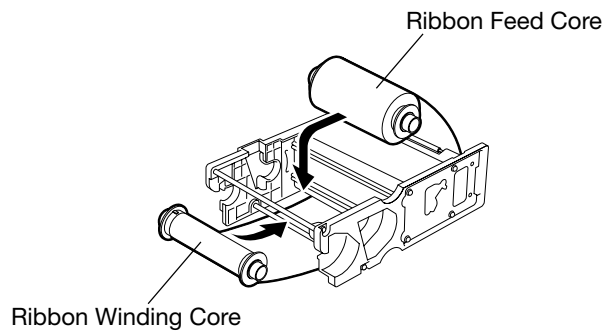

CAUTION!
Loading the ribbon upside down may cause damage to the print head, as well as print failure.

2.7.2 Loading Procedure (Cont.)

- 8 Take up any slack in the ribbon. Replace the Ribbon Module into the print head block by sliding it into the end.

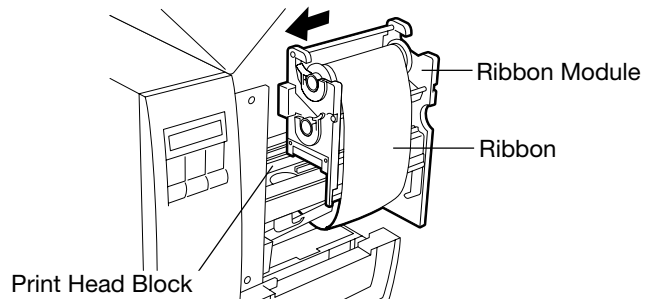

- 9 Turn the Head Lever to the LOCK position to secure the Ribbon Module. Take up any ribbon slack one more time by turning the Ribbon Winding Core.

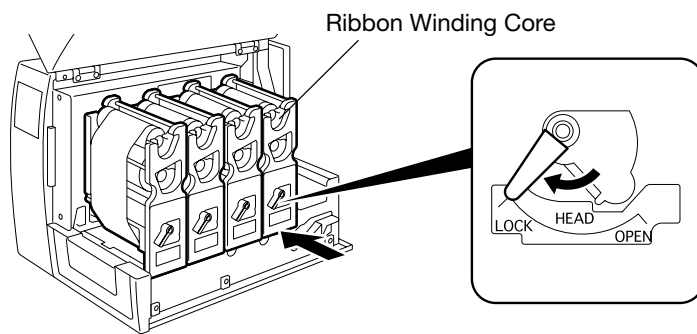

- 10 Load the other three ribbons in the same manner.
- 11 Close the Top Cover.

2.8 Loading the Ribbons (for Cold Release Ribbons)

Notes:

- Please see Section 1.4.2 for the part illustrations.
- Installing the Cool Release Enhancement Kit allows a variety of ribbons to be loaded.

This section describes how to load the popular Cold Release Ribbons. To identify a ribbon type to be loaded, refer to the table in Section 3.8.1 or contact an authorized sales representative. Before loading the Cold Release Ribbons, install the Cool Release Enhancement Kit that is composed of the following accessories.

Part Name	Quantity
Ribbon Plate	4 pcs.
Mounting Screw	4 pcs.
D-3x5 Screw	12 pcs.
SP Ribbon Guide (A)	1 pc.
SP Ribbon Guide (B)	3 pcs.
Ribbon Tension Sheet	4 pcs.
Sheet Fixing Plate	4 pcs.

2.8.1 Precautions

- 1 Depending on the operating temperature or print patterns, ribbon wrinkles or blurred printing may occur. To solve this problem, adjust the print density as follows:
 - When the ribbons wrinkle, decrease the print density.
 - When the blurred printing occurs, increase the print density.
 To change the print density, see *Section 3.7.2* for more detail.
- 2 When using the Cold Release Ribbons in high temperature (about 105°F/40°C), the sound of the ribbon being separated from the media may be heard. But that does not impact upon print quality.

2.8.2 Installing the Ribbon Plate

WARNING!

During normal printer operations, the print head will become hot. Care should be used when handling the print head to avoid personal injury.

- 1 Remove all Ribbon Modules from the print head blocks. Then lift one of the print head blocks.

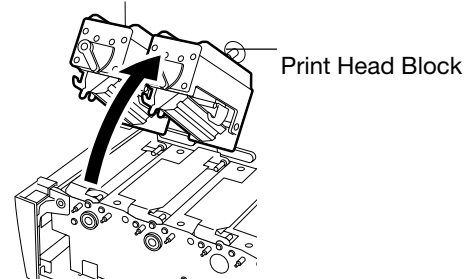

- 2 Hold the Ribbon Plate with the pin facing inside and downwards, as illustrated below.

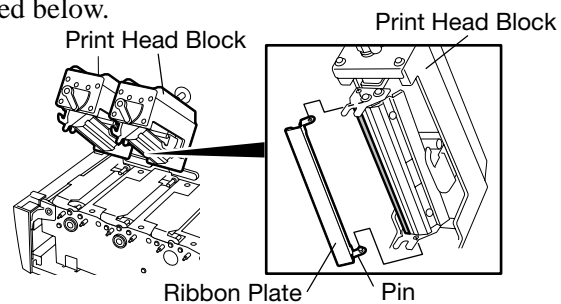

- 3 First position the Head Positioning Plate (opposite the pin side), into the small rectangular groove. Keep the Head Positioning Plate flush against the groove, as illustrated below. When attaching the Ribbon Plate to the print head block, make sure that the Head Positioning Plate makes full contact with the small rectangular groove.

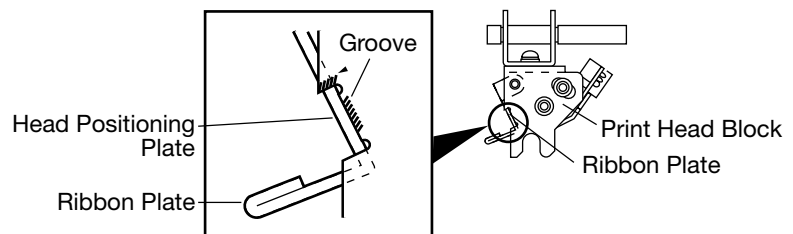

(Side View of Print Head Block and Ribbon Plate)

- 4 Slide the Ribbon Plate down slightly and insert the pin into the hole on the back of the print head.
- 5 After the pin is inserted, slide the Ribbon Plate back in the direction of the arrow and gently pull down the print head. Secure the Ribbon Plate to the print head block by tightening the Mounting Screw.

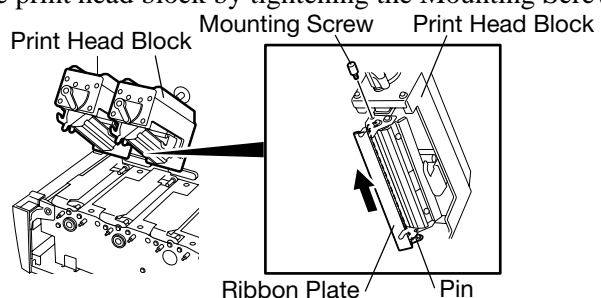

- 6 Repeat this procedure for installation of the other three print heads.

Notes:

- Be sure to return the print head to the original position.
- Tighten the screws so as not to damage the screw threads.

2.8.3 Installing the SP Ribbon Guides

- 1 Remove the Guide Plates from the printer by lifting and pulling them in the direction of the arrow.

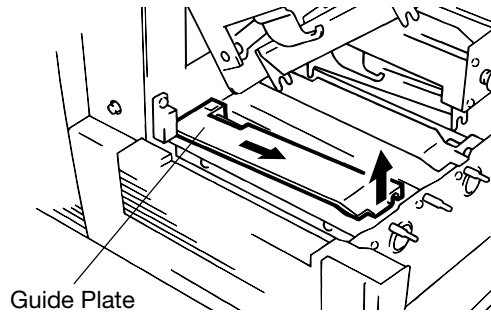

- 2 Install the SP Ribbon Guides (A) and (B) in the reverse order of removal of the Guide Plates.

Important!

- The SP Ribbon Guide (A) with the small plastic film is exclusively for the yellow print head block.
- The SP Ribbon Guides (B) with the large plastic films are for the cyan, magenta and black print head blocks.

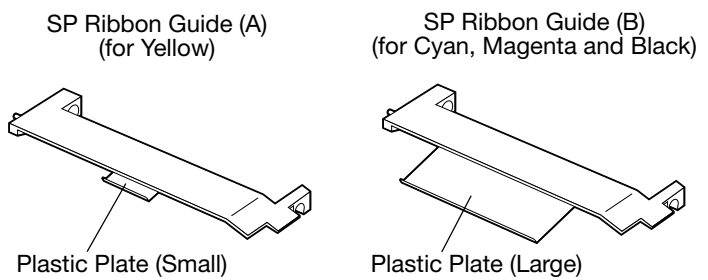

2.8.4 Installing the Ribbon Tension Sheet

- 1 Remove the Ribbon Guide Lever from the Ribbon Cassette by removing the screw.
- 2 Fit the bosses on the Sheet Fixing Plate into the holes of the Ribbon Tension sheet and the aluminum frame. Secure them with the three D-3x5 screws.

Note:
Do not reinstall the Ribbon guide Lever, Ribbon Guide Lever Shaft and the D-3x6 screw because they are not used after the ribbon tension sheet has been installed.

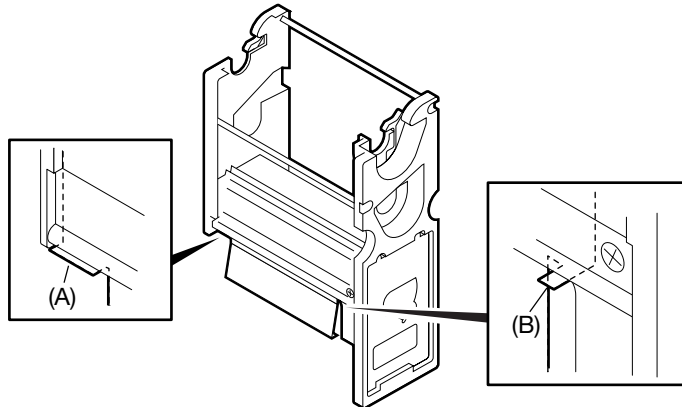
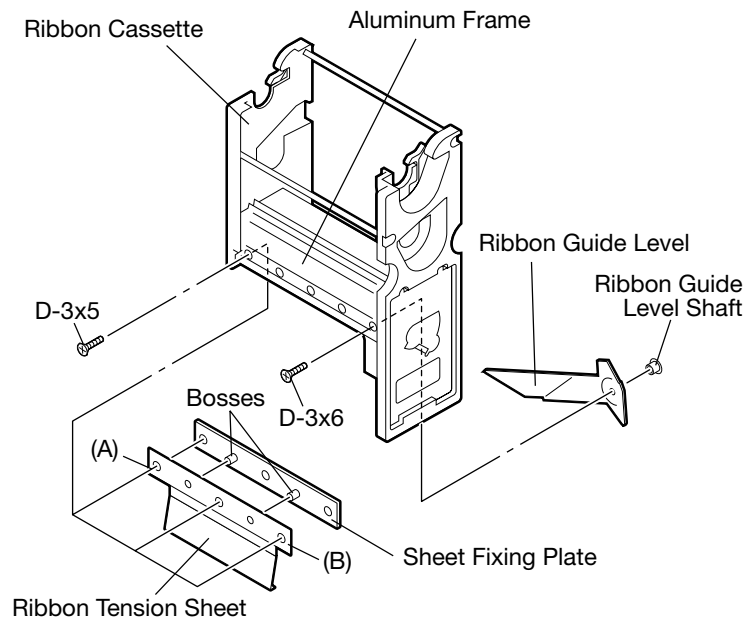

2.8.5 Loading the Cold Release Ribbons

Note:
Selecting a wrong ribbon type may cause blurred or blotted printing. Be sure to select the proper ribbon type.

Note:
Selecting a wrong ribbon motor voltage may cause ribbon wrinkles or blurred printing. Be sure to enter the proper value.

After attaching the Cool Release Enhancement Kit, the **Ribbon Settings** need to change. See *Section 3.8.1* for more detail.

- 1 Open the **Device Settings** property page on the computer, click **Ribbon Settings**, and open the **Ribbon Settings** dialog.
- 2 Click the **Type** down arrow, and select Premium (either 109mm or 68mm).
- 3 The **Ribbon Motor Voltage** may need to change.

3. Printing

Note:

In this chapter, unless otherwise specified, “click” means click the left mouse button once.

This chapter explains how to print an image or bar code using the Windows driver. First, it describes in detail how to install the printer driver. Then it describes how to modify the printer settings and fine adjustments to produce the best output. Finally it describes how to print a label.

The chapter is organized as follows:

- 1 To install the printer driver, see *Section 3.1*.
- 2 To specify the printer properties, see *Sections 3.2 to 3.8*.
- 3 To perform test printing, see *Section 3.9*.
- 4 To print an actual label from an application program, see *Section 3.10*.

3.1 Installing the Printer Driver

To use the CB-416-T3 printer with Windows, the printer driver must be installed on the computer. Labels or tags can easily be printed from a variety of application software using the CB-416-T3 printer driver.

3.1.1 System Requirements

You need an IBM PC/AT-compatible computer with:
 Microsoft® Windows® 95/98, Windows NT® Version 4.0 Workstation, or Windows NT® Version 4.0 Server.
 Pentium® 133MHz or greater recommended
 16MB of available RAM or more (32MB recommended).
 10MB or more of available hard-disk space.

3.1.2 Installation Procedure (For Windows®98)

This section has step-by-step procedures to install the TEC Printer Driver Version 6.2 build 20 for Windows®98.

Preparation

Make preparations for the installation of the printer driver as follows:

- 1 Insert Disk 1 in the floppy disk drive.
- 2 Click the **Start** button. Then click **Run**.
- 3 Type “a:setup” in **Open**, and then click **OK**.

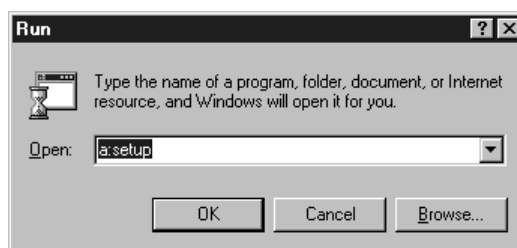

Notes:

- For further information about the installation procedure for Windows® NT, please contact your authorized service representative.
- The printer driver may be upgraded without notification. For further information about the download of the upgraded printer driver, please access the following URL.
<http://barcode.toshibatec.co.jp>

3.1.2 Installation Procedure (Cont.)

4 TOSHIBA TEC PRINTER DRIVER Setup Wizard is initiated. Click Next.



5 To accept License Agreement, click Yes. If it is not acceptable, click No. However, the printer driver cannot be installed.

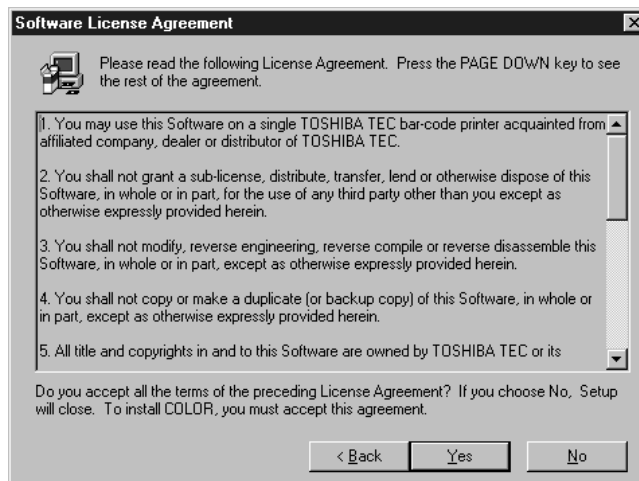

6 Choose a destination folder to install COLOR. To install it in C:\TEC_DRV\COLOR, click Next. The installation of COLOR begins. To install it in another destination, click Browse.



3.1.2 Installation Procedure (Cont.)

- Remove Disk 1. Insert Disk 2 in the floppy disk drive. Click **OK** to continue the setup.



- Setup Complete** appears, when the setup successfully completes. Click **Finish**.

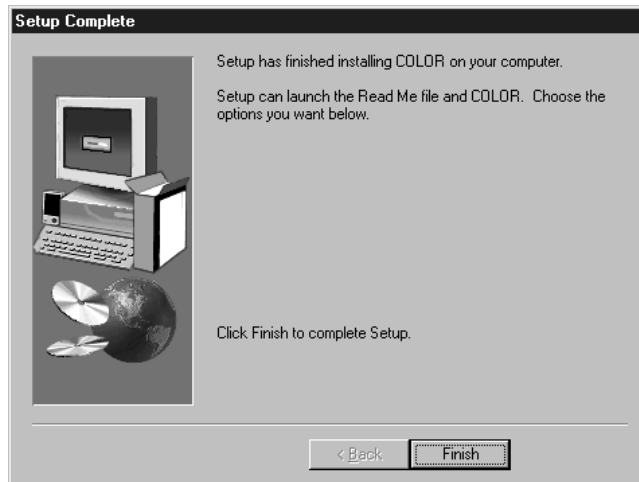

- Start the Windows Explorer. Verify that the **Color** folder was created in the **TEC_drv** folder on the C drive.

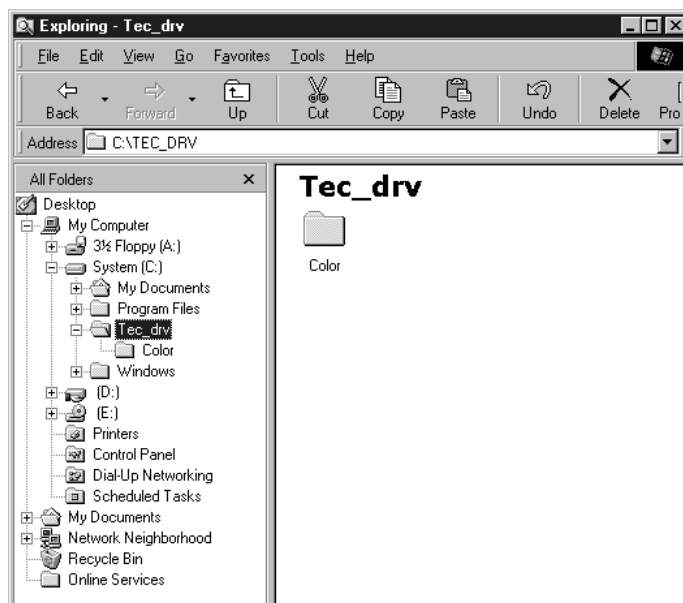

3.1.2 Installation Procedure (Cont.)

Adding the Printer (For Windows®98)

Install the printer driver as follows:

- 1 Click the **Start** button. Choose **Settings**, and click **Printers**. The **Add Printer** icon appears.



- 2 Double-click the **Add Printer** icon, and **Add Printer Wizard** is initiated. Click **Next** to add the CB-416 printer.

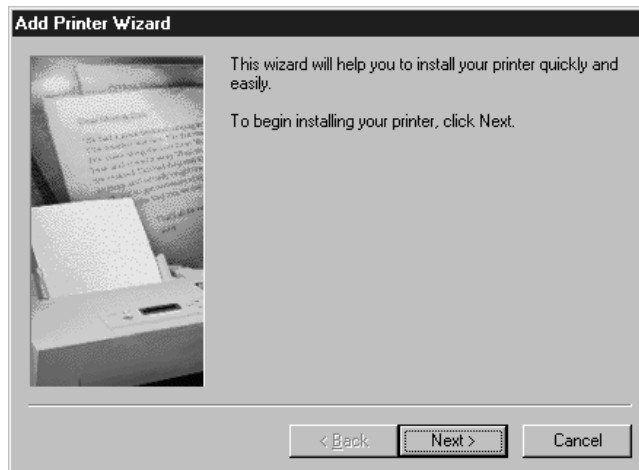

- 3 Choose whether the printer is used as **Local Printer** or **Network Printer**. Then click **Next**.

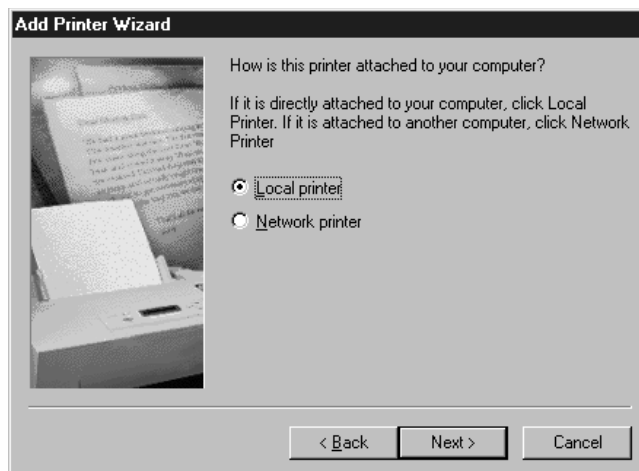

3.1.2 Installation Procedure (Cont.)

4 Click **Have Disk**.

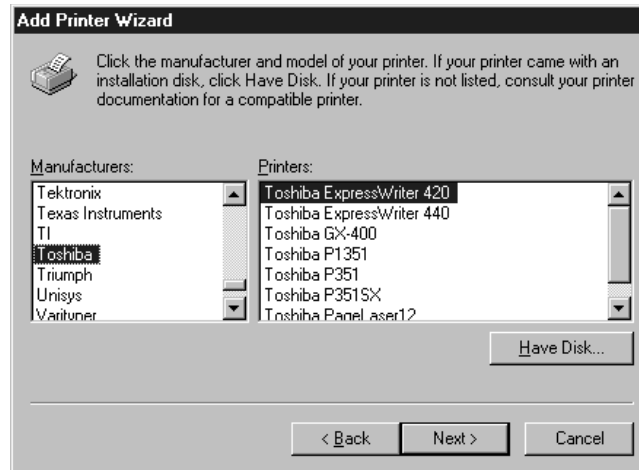

5 Type in “C:\TEC_DRV\COLOR”, and click **OK**.



6 Choose **CB-416-T3** from the printer list, and click **Next**.

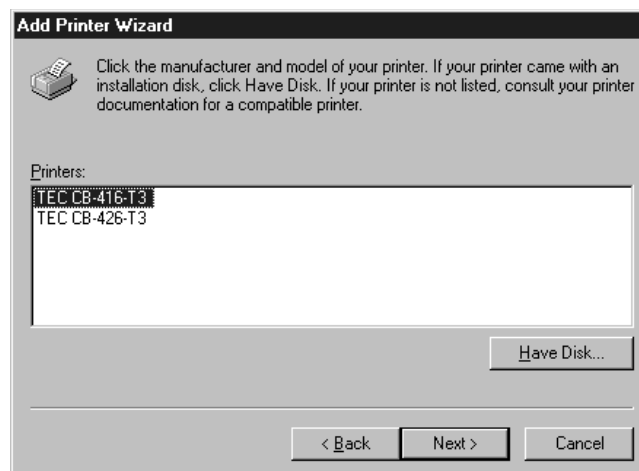

3.1.2 Installation Procedure (Cont.)

Notes:

- The ECP Printer port is recommended.
- Please refer to the user's manual of your computer for further information regarding the setting of the ECP Printer port.

7 Choose the port that the printer is connected to, and click **Next**.



8 Type in a printer name that you prefer to use.

Note:
If no printer driver has been installed before, this printer will be used as a default printer automatically.

9 Select whether the printer will be used as the default printer for all applications. Then click **Finish**.

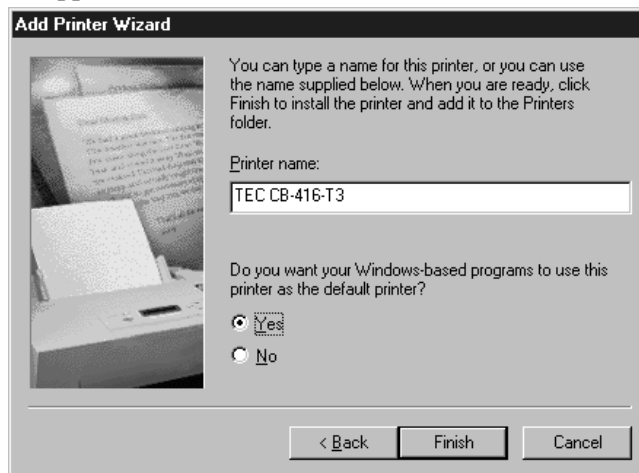

10 Finally, make sure that the **CB-416-T3** icon has been added in **Printers**. Installation of the printer driver has been completed.

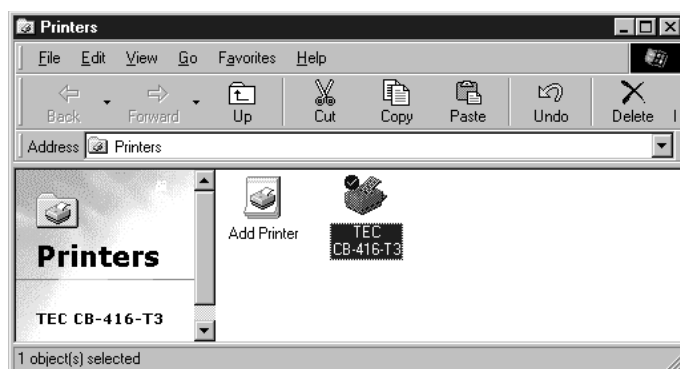

3.1.3 Uninstalling the Printer Driver

Note:
Start uninstalling the printer driver after closing all application programs.

Note:
Remove the icon by right-clicking the icon, and choosing and clicking **Delete**.

Perform the following steps to uninstall the printer driver.

- 1 Click the **Start** button. Choose **Settings**, and click **Printers**. Choose the **CB-416-T3** icon.

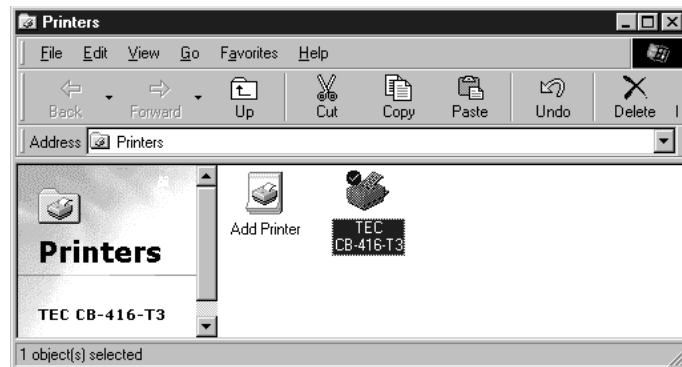

- 2 On the **File** menu, click **Delete**. Please be sure that the **CB-416-T3** icon is removed.

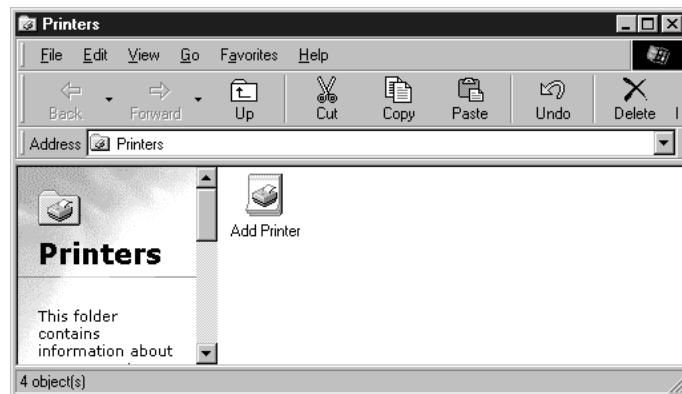

The printer driver is uninstalled now.

3.1.3 Uninstalling the Printer Driver (Cont.)

Important!

When upgrading the printer driver, the folder needs to be deleted as follows:

- 1 Click the **Start** button. Choose **Settings**, and click **Control Panel**.
- 2 Double-click the **Add/Remove Programs** icon.
- 3 **Add/Remove Programs Properties** appears. Choose **TOSHIBA TEC PRINTER COLOR**, and click **Add/Remove**.
- 4 The **Confirm File Deletion** dialog box appears. Click **Yes**, and the removal of the printer driver begins.

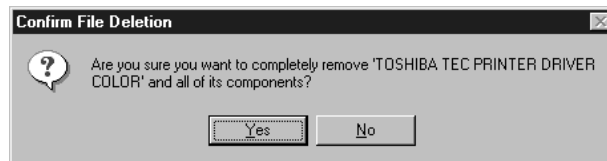

- 5 The printer driver is removed successfully. Click **OK**.

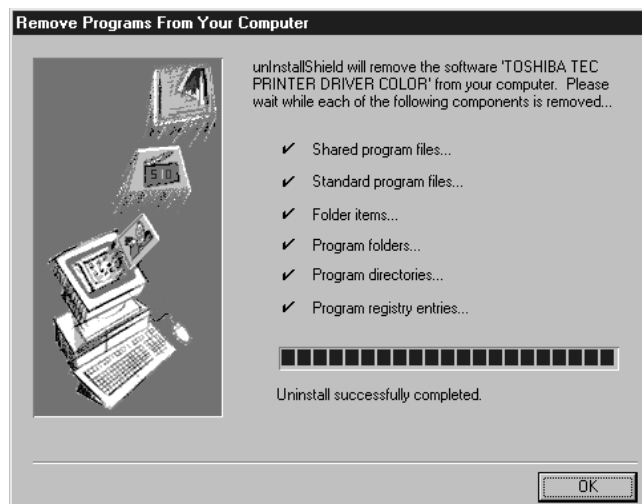

3.2 Properties

This section summarizes the main properties that can be specified to ensure the best printer performance.

Please refer to the later sections describing the property settings in detail.

3.2.1 Displaying Printer Properties

- 1 Click the **Start** button. Choose **Settings**, and click **Printers**.

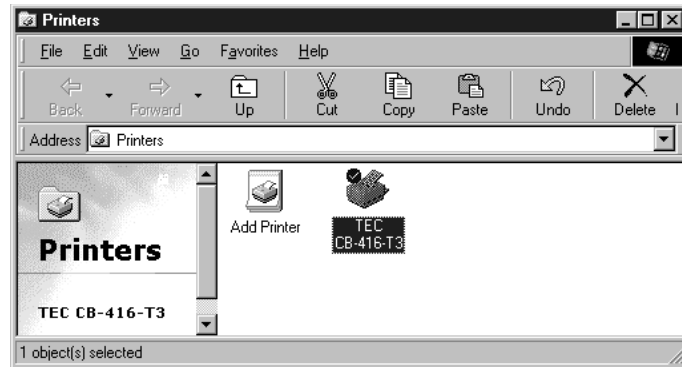

- 2 On the **File** menu, click **Properties**. **TEC CB-416-T3 Properties** appears.

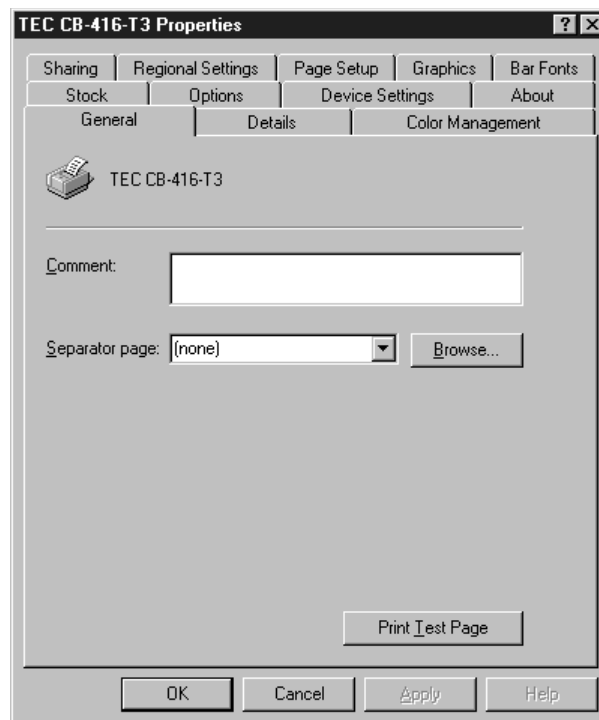

3.2.2 Summary of Properties

Note:
Some of the properties may have to be set again in the application programs.

This is a summary of the main properties for CB-416-T3.

- On the **Page Setup** property page, specify the default label size and orientation settings. In addition, other label sizes can be created, then accessed through your application's page setup dialog. See *Section 3.3* for more detail.
- On the **Graphics** property page, how text and images will be printed on the labels or tags can be specified. See *Sections 3.4* for more detail.
- On the **Bar Fonts** property page, internal bar code fonts can be added, deleted, modified, imported, exported and viewed. See *Section 3.5* for more detail.
- On the **Stock** property page, print conditions including selection of the media sensor to be used, the issue mode and fine adjustments can be specified. See *Sections 3.6* for more detail.
- On the **Options** property page, the transfer mode of graphics data and print density adjustments can be specified. See *Section 3.7* for more detail.
- On the **Device Settings** property page, the type of ribbon to be used, can be specified. The **Device Settings** property page is also used for test print and maintenance purposes. See *Section 3.8* for more detail.
- On the **Regional Settings** property page, the units of measurement (**inches** or **centimeters**) and the language in which your driver is displayed can be specified.
- On the **About** property page, the printer driver information that includes the version number and licence agreement can be viewed.

3.3 Page Setup

This section describes in detail how to specify the default label size, orientation and how to create other label sizes that then can be accessed through an application's page setup dialog.

Click the **Page Setup** tab to open the **Page Setup** property page.

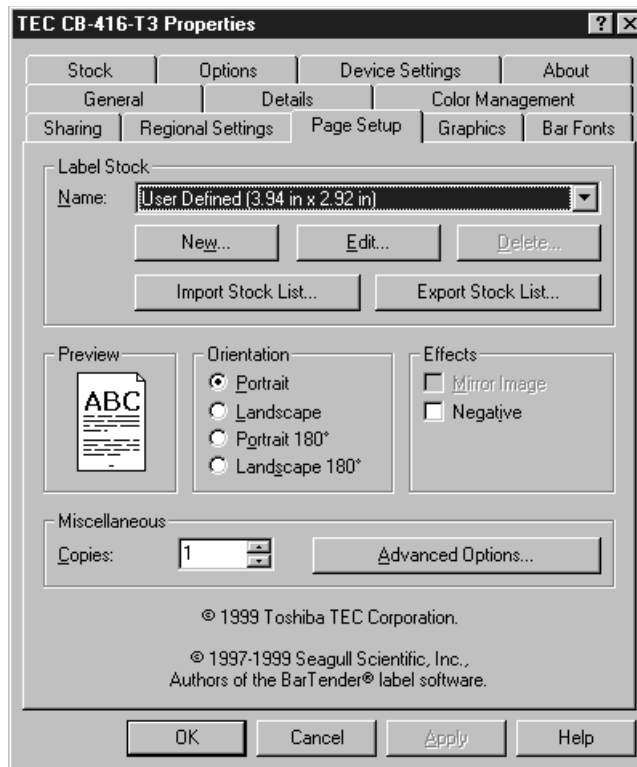

3.3.1 Selecting a label size

Click the **Name** down arrow to select a desired label size from the predefined label sizes: **2 x 4**, **4 x 4**, **4 x 6** or **User Defined**.

Note:
The setting made in this section can be saved in the file as a preferred setting for a particular print job. See Section 3.3.4 for more detail.

- Use **Import Stock List** to import previously defined label sizes from other compatible printer drivers.
- Use **Export Stock List** to save defined label sizes to a file so they can later be imported into other printer drivers with this capability.

3.3.2 Creating a new label size

To create your own label size :

- 1 Click **New**, and **Edit Label Stock** appears.

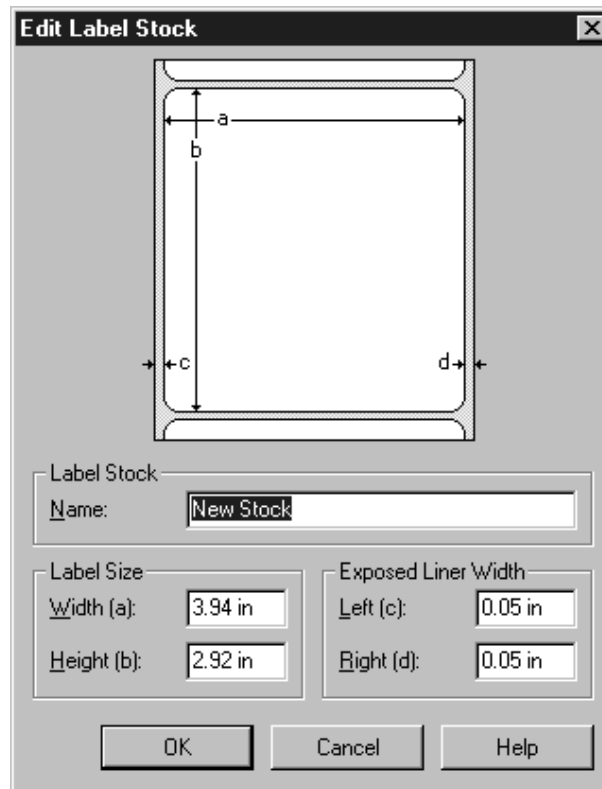

- 2 Enter a new label stock name in **Name**.
- 3 Change **Label Size (Width and Height)** and **Exposed Liner Width (Left and Right)**. Click **OK** to return to the **Page Setup** property page.
- 4 Click **Edit** to change the label name, label size, or exposed liner size that is defined in Step 3.
- 5 To delete a label size that you created, select it in **Name**, and click **Delete**. When the confirmation dialog box appears, click **Yes**.

Note:
User Defined cannot be renamed.

Note:
Delete is grayed out when the predefined label sizes are selected. In other words, you cannot delete them.

3.3.3 Orientation

Notes:

- A preview will be shown, as each option is selected.
- The setting made in this section can be saved in the file as a preferred setting for a particular print job. See Section 3.3.4 for more detail.

Select the print image orientation to determine the direction that the print image will be issued

- Click **Portrait**, and the bottom of the print image comes out of the printer first.

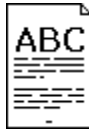

- Click **Landscape**, and images are rotated 90° counterclockwise from the portrait orientation. The left edge of the print image comes out of the printer first.



- Click **Portrait 180°**, and the top of the print image comes out of the printer first.

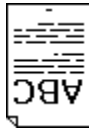

- Click **Landscape 180°**, and images are rotated 90° clockwise from the portrait orientation. The right edge of the print image comes out of the printer first.



Note:

- **Effects** is not available for this version.

3.3.4 Miscellaneous

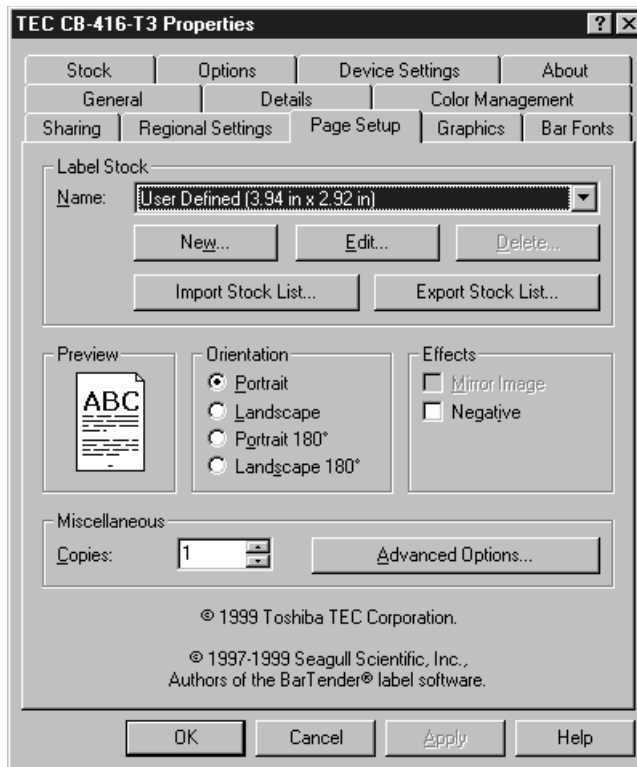

- Click **Copies** to enter the default number of copies that the printer will print.
- Click **Advanced Options**. The **Advanced Options** Screen appears to implement the following functions:

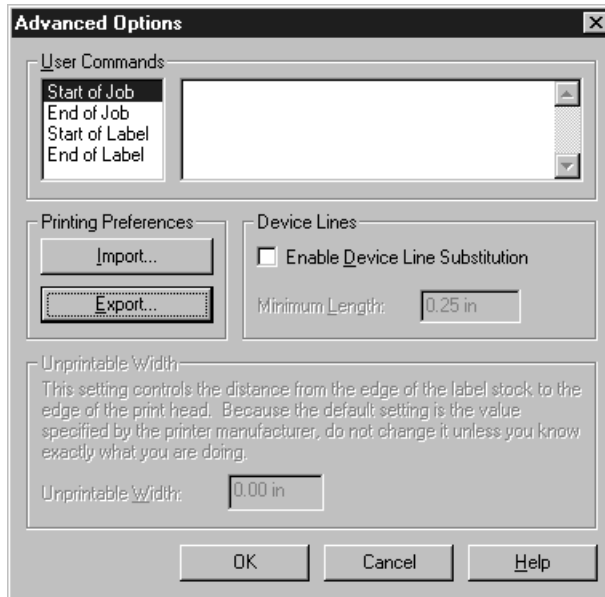

User Commands

Printer commands can be added at the beginning or the end of a print job.

Please note familiarity with application programs and commands is required. Otherwise the printer may not function, as desired.

Note:
 The User Commands specified here can be saved in the file as the preferred User Commands for a particular print job.
 See the Printing Preferences below.

3.3.4 Miscellaneous (Cont.)

Printing Preferences

- In **Printing Preferences**, the preferred settings can be saved in the file for a particular print job. If several kinds of print jobs are performed, it is strongly recommended to use this function to save the preferred settings in the file for each print job.

When using **Printing Preferences**, the following settings can be saved. For more details of each setting, see the section indicated in the right column of the table below.

Tab	Settings	See Section ...
Page Setup	Name	3.3.1
	Orientation	3.3.3
	User Commands	3.3.4
Graphics	Dithering	3.4.1
	Color Control	3.4.3
Stock	Print Method	3.6.1
	Sensor	3.6.2
	Label Gap	3.6.3
	Issue Mode	3.6.4
	Cut	
	Cut Interval	3.6.5
	Feed (Fine Adjustment)	
	Back feed (Fine Adjustment)	
Options	Cut/Strip (Fine Adjustment)	3.7.1
	Transfer Mode	
	Print Density Adjustment (YMCK)	

Note:
 Regardless of whether the **Set Check** box is marked or not, the shaded area will be enabled when saved as the preferred settings.
 See Sections 3.6.5 and 3.7.2 for more detail.

3.3.4 Miscellaneous (Cont.)

To save the settings indicated in the table, use the following procedures:

- 1 Click **Advanced Options** on the **Page Setup** property page. The **Advanced Options** screen appears.

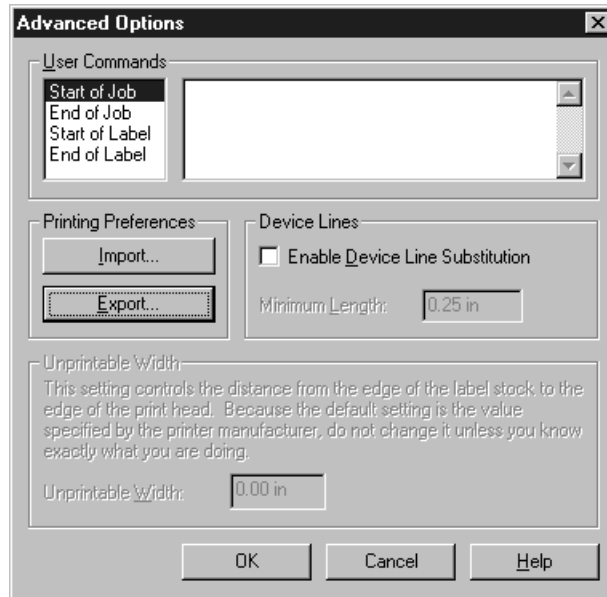

- 2 Click **Export**. The **Save Devices Settings File** screen appears.

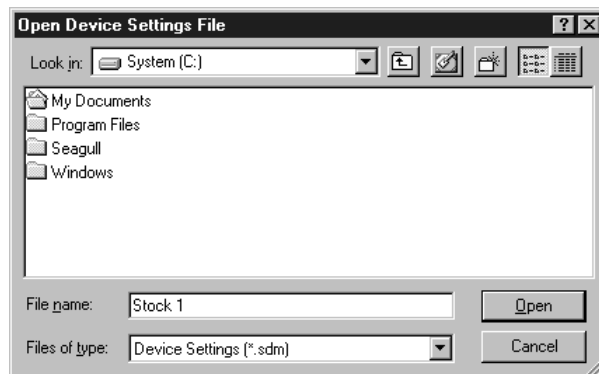

- 3 Type the file name in **File Name**.
- 4 Click **Save**. The screen returns to **Advanced Options**.
- 5 Click **OK** to return to the **Page Setup** property page. The settings shown on the table are saved in the file.

3.3.4 Miscellaneous (Cont.)

To enable the saved settings, use the following procedures:

- 1 Click **Advanced Options** on the **Page Setup** property page. The **Advanced options** screen appears.

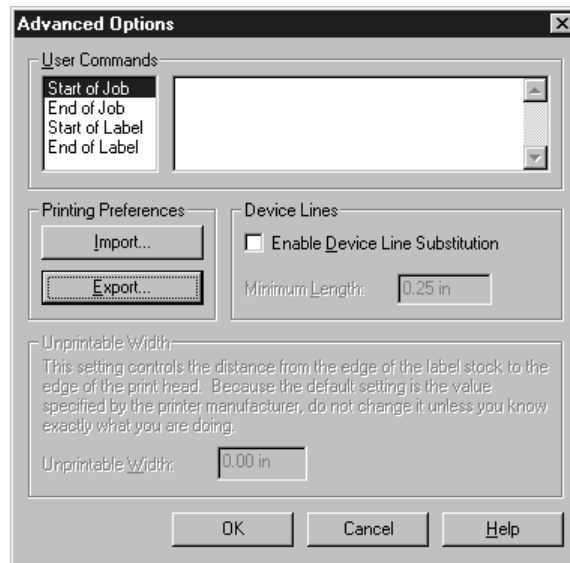

- 2 Click **Import**. The **Open Device Settings File** screen appears.

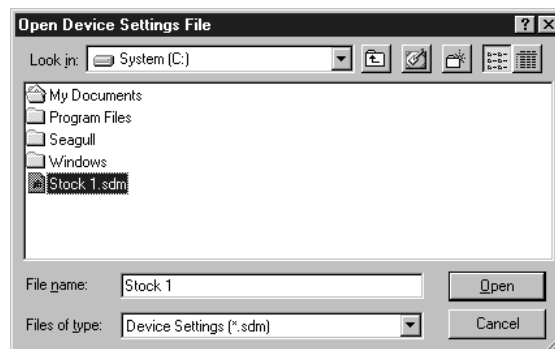

- 3 Select the saved file and click **Open**. The screen returns to **Advanced Options**.

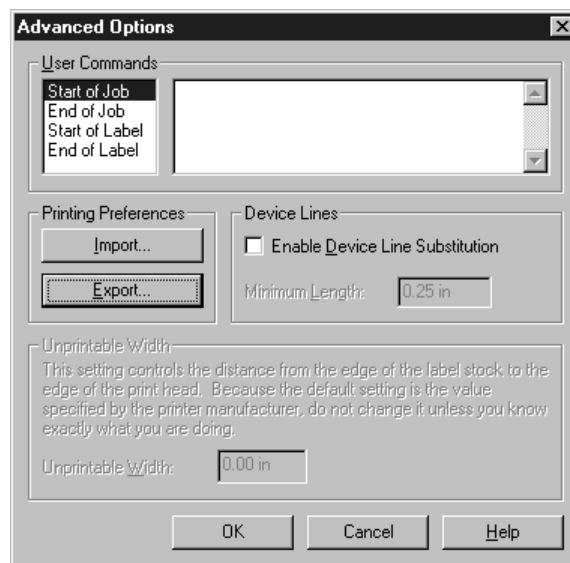

- 4 Click **OK** to return to the **Page Setup** property page. The saved settings take effect.

3.4 Graphics

This section describes in detail how to specify a graphic image that will be printed on a label, color control, color registration, and spot color setup.

Click the **Graphics** tab to open the **Graphics** property page.

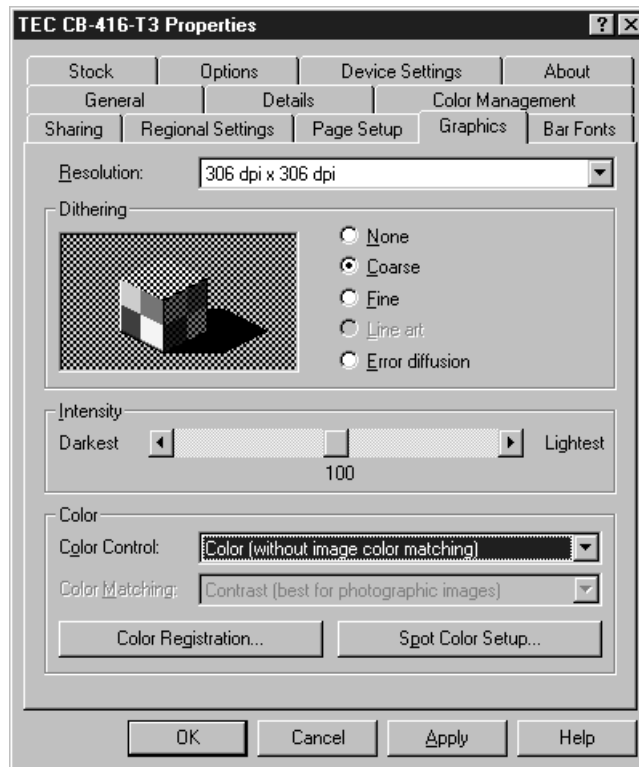

3.4.1 Dithering

Many application programs allow label or tag design with different colors and shades of gray. However each thermal print head can only print one color. So by outputting different dot-patterns, each color can be printed in what appears to be different shades.

Select one of the following four settings to suit the print requirements.

- **None** outputs the sharpest images when printing bitmap graphics that contain only standard solid colors, no shading.
- **Coarse** does the best job of printing lots of different shades of color, but will soften the edges of graphic image the most.
- **Fine** retains greater clarity in higher resolution graphic images than the “Coarse” setting, but cannot print as many different shades of color.
- **Error diffusion** creates a random pattern to avoid the regular pattern received when using either the “Coarse” or the “Fine” setting.

Refer to the separate color print sample sheet, and compare the differences.

Notes:

- **Line art** is grayed out, as it is not available for this model.
- The setting made in this section can be saved in the file as a preferred setting for a particular print job. See Section 3.3.4 for more detail.

3.4.2 Intensity

Note:
The **Intensity** setting has nothing to do with controlling print-head temperature.

3.4.3 Color

Note:
The setting made in this section can be saved in the file as a preferred setting for a particular print job. See Section 3.3.4 for more detail.

3.4.4 Color Registration

Note:
Alignment of colors may vary due to differences in thickness or type of media.

Slide the lever from side to side or click either side of the arrows to control the darkness and lightness of shaded bitmap images. However the **Intensity** setting does not change the darkness of pure black images, or non-graphic objects, such as bar codes and text fields. Refer to the separate color print sample sheet, and compare the differences.

Click the **Color Control** down arrow to specify whether to print in **Monochrome** or **Color without image color matching**. When printing in color, select **Color without image color matching**.

This section describes how to precisely align all colors. Color Registration is factory-adjusted. However if any color is misaligned, please perform the color registration procedures.

- 1 Click **Color Registration** on the **Graphics** property page.

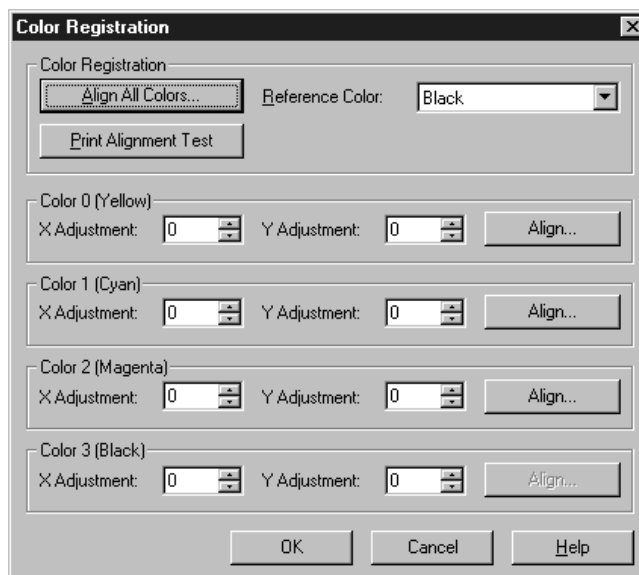

- 2 Select **Reference Color**. **Black** is the default reference color. The color selected here is used as the reference color to which other colors are aligned. (This section describes the procedure using **Black** as the reference color.)

- 3 Click **Print Alignment Test** to quickly determine which color requires alignment to the reference color. Perform color registration for any color that is not aligned to the reference color.

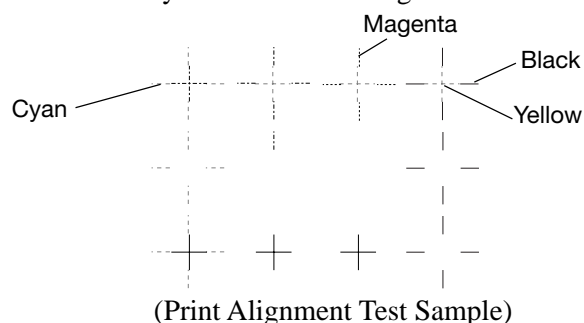

Notes:

- You can skip this step, and proceed with Step 4.
- The "Error Writing to LPT1" message appears when performing the **Print Alignment Test** without connecting the printer to the computer.

3.4.4 Color Registration (Cont.)

- 4 Suppose the yellow needs to be more aligned to the reference color.
 - Click **Align in Color 0 (Yellow)**. **Align Color: Yellow/Black** appears.

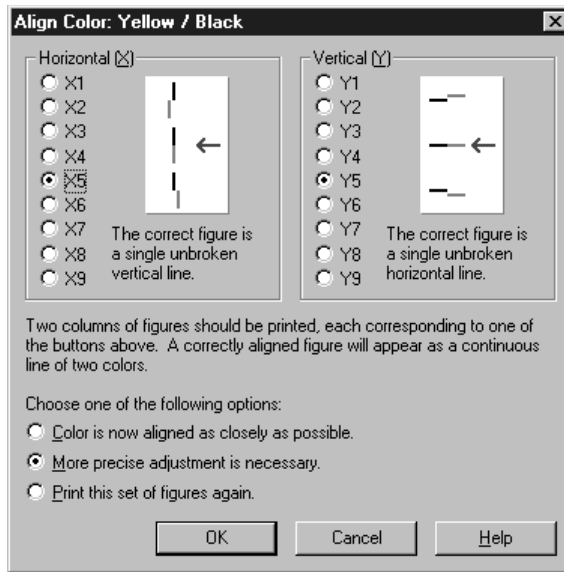

Notes:

- The **“Error Writing to LPT1”** message appears when performing **Align All Colors** without connecting the printer to the computer.
- If **Align All Colors** starts, it will take a long time to complete since it continues until alignment for all colors is finished.

- 5 Print testing runs automatically. The printed output shows how precisely the yellow bars are aligned to black.

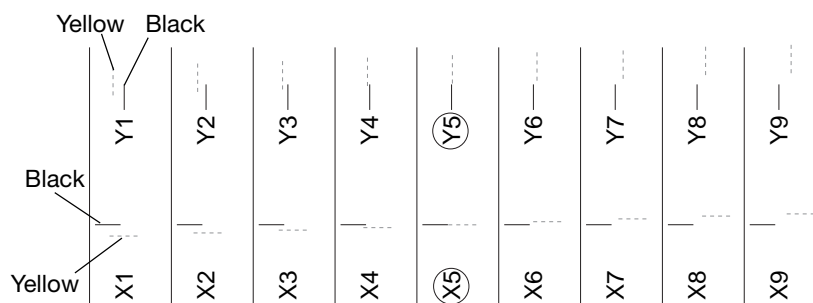

(Color 0 - Yellow Sample)

- 6 Look at the result carefully. Determine which yellow bar is best aligned to black on X (horizontal) and Y (vertical) for each. In this example, X5 and Y5 are best aligned.
- 7 In step 6, since X5 and Y5 are best aligned, click **X5** in **Horizontal (X)**, and **Y5** in **Vertical (Y)** on **Align Color : Yellow/Black**.
 - If the yellow bars in both X and Y are aligned enough to black, go to Step 8.
 - If the yellow bars need to have more precise alignment to black, go to Step 9.
 - If the test needs to be performed again, go to Step 10.
- 8 Click **Color is now aligned as closely as possible**. Then click **OK**.

3.4.4 Color Registration (Cont.)

Note:
If precise adjustment cannot be made any more, this option will be grayed out.

9 Click **More precise adjustment is necessary**. Click **OK**, and test printing starts automatically. Repeat Step 4 to 6 until the yellow bars in X and Y are aligned close enough to black.

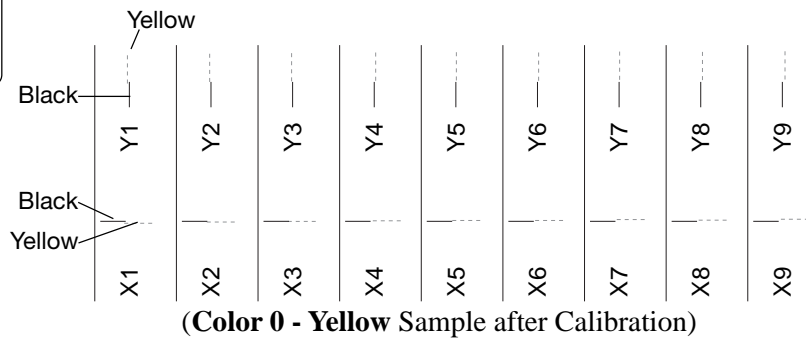

10 Click **Print this set of figures again**. Testing will start automatically.

3.4.5 Spot Color Setup

This section describes spot color printing. In Spot Color Setup, up to four colors can be selected. Generally, spot color printing is used for printing applications that require exact color matching. Spot color printing has the following advantages:

- Special colors available.
- Cost efficiency (since four ribbons are not required to produce one color).
- Colors and text printing are sharper.

1 Click **Spot Color Setup** on the **Graphics** property page to open **Color Setup**.

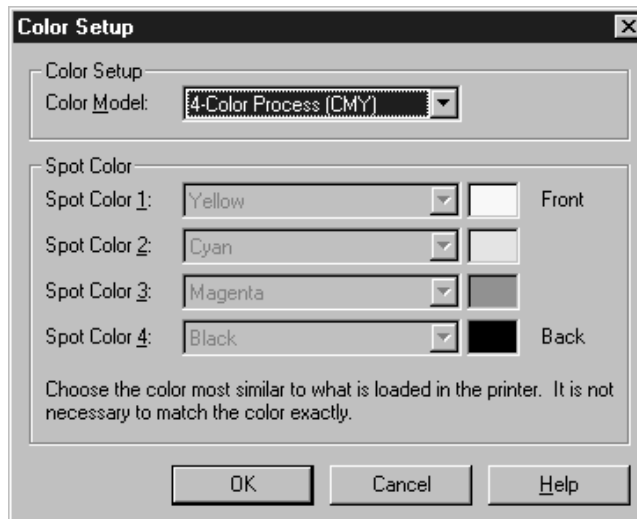

Note:
Click **Help** for a detailed explanation of the differences between **Process** and **Spot**.

- 2 Click **Color Model** down arrow, and select the color method.
- Click **4-Color Process (CMY)** for producing the best possible graphics. This is selected as the default color model.
 - Click **4-Color Process (CMYK)** for producing an image containing solid blacks and/or text.
 - Click **2-4 Spot Colors**. Up to four print table colors can be selected.

3.4.6 Spot Color Printing

Suppose a logo needs to be printed on a label in blue and red.

Note:
Spot Color 1 is equivalent to the position of the yellow ribbon for the 4-color process.

- 1 Remove the yellow and Cyan ribbons from the printer.
- 2 Load the blue and red ribbons in the printer respectively.
- 3 Select and click **2 Spot Colors**. Specify **Blue, Purple** in **Spot Color 1**, and **Red, Orange** in **Spot Color 2**. Click **OK**.

3.5 Bar Fonts

This section describes how to add, delete, modify, import, export, and view available internal bar code fonts. The **Bar Fonts** properly format and add necessary characters to the bar codes printed when using the internal bar fonts.

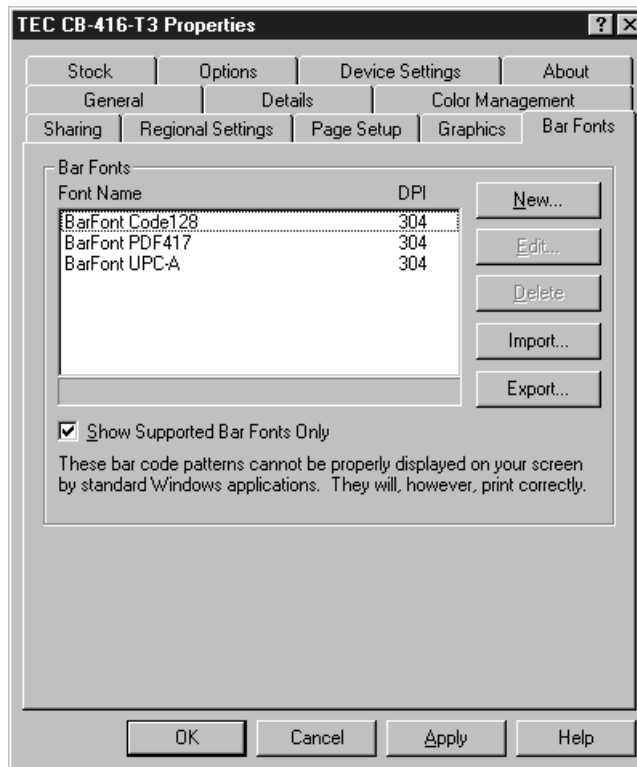

- **Font Name** lists the currently entered bar fonts and their resolution.
- If the **Show Supported Bar Fonts Only** checkbox is marked, only the bar fonts matching current head density are shown.
- Click **New** or **Edit**. The **Edit Bar Code Font** dialog appears. When one of the bar fonts is selected, and then **New** or **Edit** is clicked, the bar font will be based on the selected one. See *Section 3.5.1* for more detail.
- Click **Delete**, and the selected bar font in **Font Name** will be deleted.
- Click **Import** to import a list of bar code fonts that have previously been exported.
- Click **Export** to export the current bar code font list to a file with the extension “.sbf”.

3.5.1 Specifying a New Font Style

Note:

To specify the height of a bar code, the font size should be changed in the application programs.

Bar font styles can be added or modified from the bar font list. More detailed bar code settings can be made, including size of bar code (character per inch), orientation, necessities of human-readability and check digit.

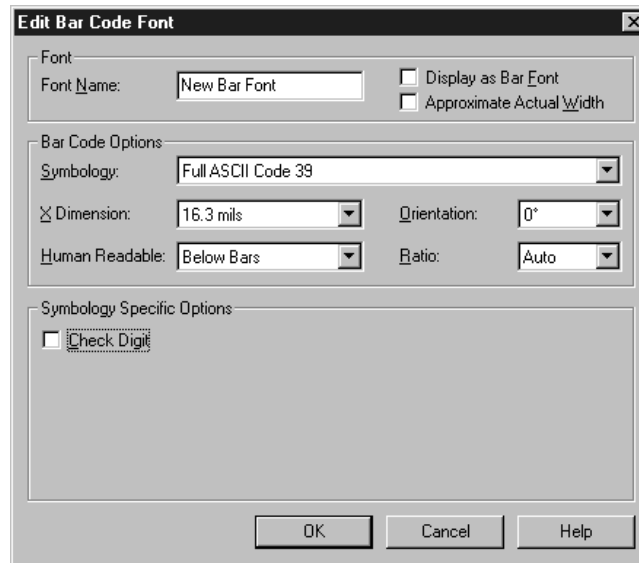

Notes:

- Depending on which symbology is selected, the different **Symbology Specific Options** will be available. Click **Help** for more detail.
- When **Orientation** is 90° or 270° and **X dimension** is 0.25 mm or over, the recommended print speed is 4 inches/s. See Section 3.6 for the print speed.

- In **Font Name**, type a name of a bar font.
- Mark the **Display as Bar Font** checkbox. When a bar font is selected in the application software, an image representing the bar code will appear on the screen. Note that the exact bar code itself is not shown on the screen.
- Mark the **Approximate Actual Width** checkbox. When a bar font is selected in the application software, the estimated size is shown.
- Click the **Symbology** down arrow to select the type of symbology.
- Click the **X Dimension** down arrow to specify thickness of bars or cells, depending on the selected symbology.
- Click the **Orientation** down arrow to rotate the symbology.
- Click **Human Readable** to specify the visibility of the human readable characters displayed with the bar codes.
- Click **Ratio** to specify the wide-to-narrow element ratio of the bar code. (This option is available only when used with Full ASCII 3-of-9, Regular 3-of-9, Codabar, Interleaved 2-of-5, and MSI Plessey only.)

3.5.1 Specifying a New Font Style (Cont.)

The bar fonts entered in the printer are shown in the application programs, as below.

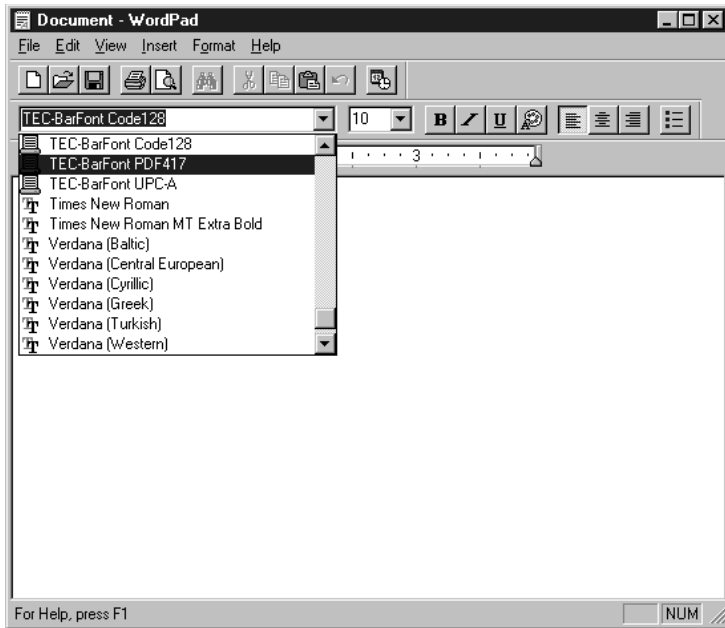

3.6 Stock

This section describes how to specify the print method, sensor, and label gap.

Click the **Stock** tab to open the **Stock** property page.

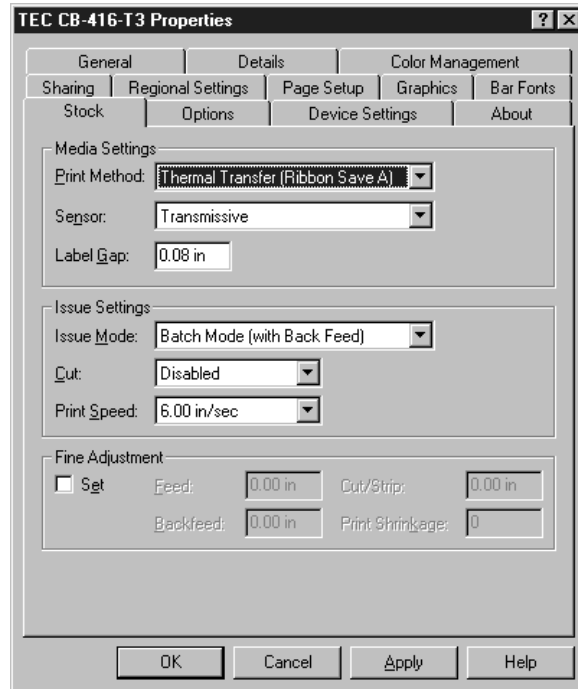

3.6.1 Print Method

Note:

The setting made in this section can be saved in the file as a preferred setting for a particular print job. See Section 3.3.4 for more detail.

Click the **Print Method** down arrow, and select **Thermal Transfer (Ribbon Save A)**.

3.6.2 Sensor

Notes:

- See Sections 2.5 and 2.6 for more detail.
- The setting made in this section can be saved in the file as a preferred setting for a particular print job. See Section 3.3.4 for more detail.

The type of sensor can be selected, depending on type of media.

Click the **Sensor** down arrow to select the type of sensor, which depends on type of media.

- Click **Transmissive** to use the transmissive sensor. This sensor is designed to locate label gaps by the transmission of light.
- Select **None**, if there is no label gap, notch, or black mark. When **None** is selected, even if any gap, notch, or black mark is on the label, it is ignored.
- Select **Reflective** to use the reflective sensor. This sensor is designed to locate black marks on the back of the tags by the reflection of light.

3.6.3 Label Gap

Notes:

- This measurement is ignored if **None** is specified in **Sensor**.
- The setting made in this section can be saved in the file as a preferred setting for a particular print job. See Section 3.3.4 for more detail.
- See A1.3.2 and A1.3.3 for gap specification.

Enter the amount of space between labels (label gap) or width of a black mark in **Label Gap**. If a proper value is not entered, the print start position will be misaligned.

3.6.4 Issue Settings

Note:
The settings made in this section can be saved in the file as the printing preferences for a particular print job. See Section 3.3.4 for more detail.

Issue mode, cut interval and print speed can be specified.

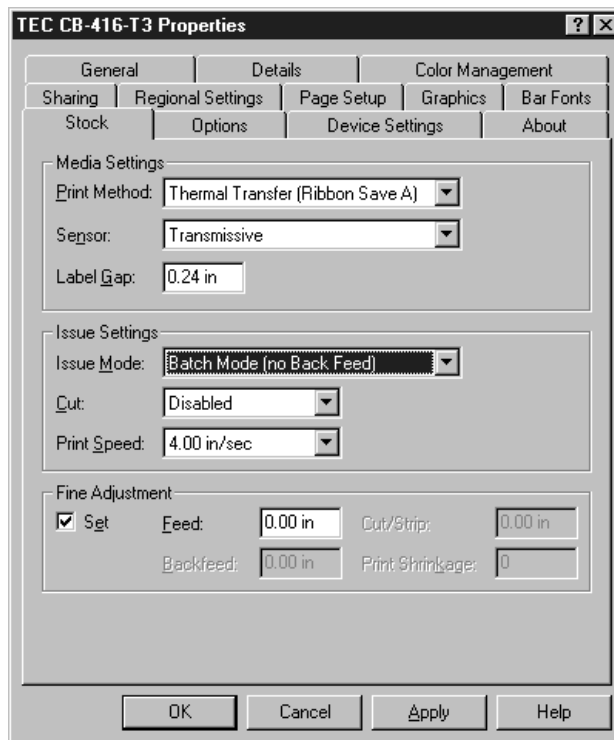

Note:
Please select **Batch Mode (with Back Feed)**, if the Cutter Module (option) is installed on the printer.

Click the **Issue Mode** down arrow, and select either **Batch Mode (with Back Feed)** or **(no Back Feed)**.

Note:
DIP Switch A Switch 2 must be **ON** to enable the cutter. See Appendix A2 for the setting of the switches.

In **Cut**, **Disabled** is selected by default.

However if the Cutter Module (option) is installed on the printer, click the **Cut** down arrow, and select one of the following options:

- Select **After Every Label**, if a cut is required after each label is printed.
- Select **After Entire Job**, if a cut is required after the entire print job is printed.
- Select **Specified Interval**, if a cut is required after the number of labels, specified in **Interval** is printed. The cut interval option defaults to 3. In other words, cutting is performed every third label. The value in **Interval** can be changed by entering a new value.

Note:
When selecting 90° for the orientation of the bar font, select 4 inches/sec.

Click the **Print Speed** down arrow, and select either 6 inches (152.4mm)/s or 4 inches (101.6mm)/s.

3.6.5 Fine Adjustment

Note:

The settings made in this section can be saved in the file as the printing preferences for a particular print job. See Section 3.3.4 for more detail.

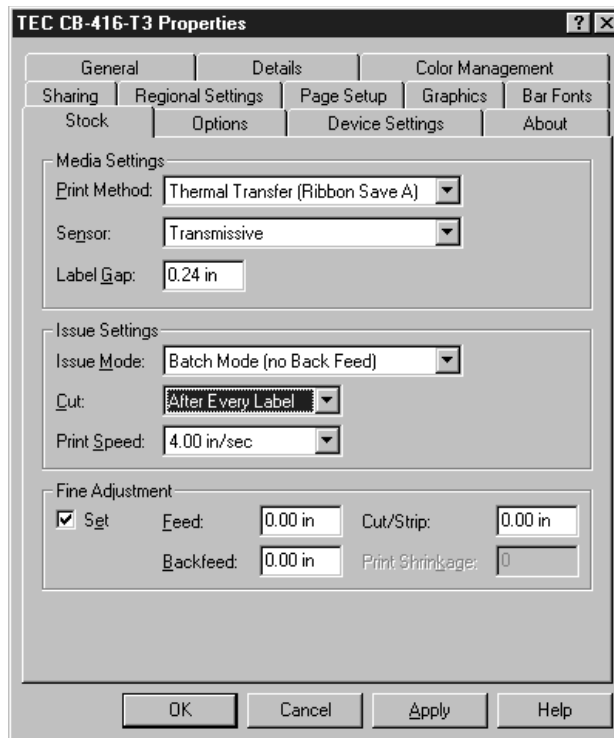

In **Fine Adjustment**, the following can be adjusted.

First mark the **Set** checkbox, and the items which can be adjusted will appear. Depending on the **Issue Settings**, some of the items cannot be adjusted. (They are grayed out.)

Notes:

- See Appendix 5 for further information.
- For back feed and cut/strip fine adjustments, the Cutter Module must be installed and enabled.

- In **Feed**, the print start position can be adjusted.
- In **Backfeed**, the length of label stock that is fed back before printing, can be specified. Depending on the type or size of media, the print start position of **ONLY** the **FIRST** label or tag may be different from what is defined in the **Feed** fine adjustment. If there is a difference that is not permissible, adjust the back feed distance. This adjustment does not have any impact upon the print start position after the first label or tag.
- In **Cut/Strip**, the cut position can be adjusted.

3.7 Options

This section describes how to specify the transfer mode of graphics data and make a print density adjustment.

Click the **Options** tab to open the **Options** property page.

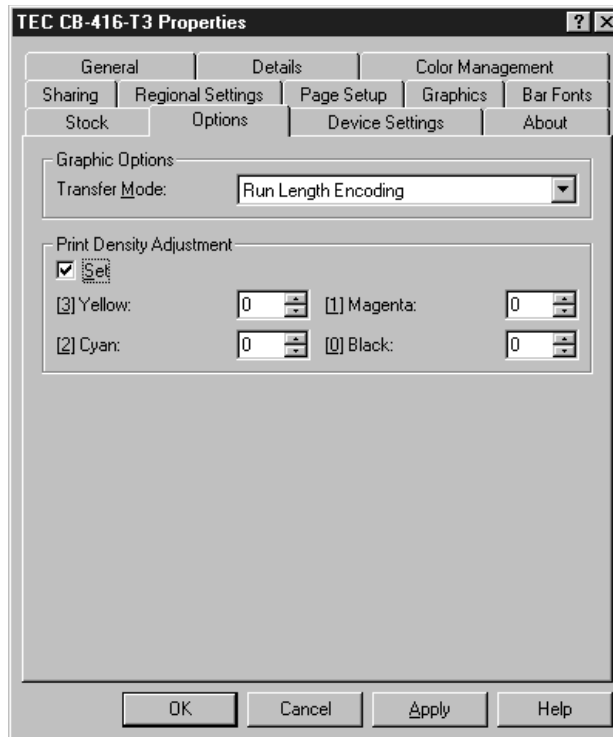

3.7.1 Transfer Mode

Notes:

- This setting may need to be changed depending on the computer configuration.
- The setting made in this section can be saved in the file as a preferred setting for a particular print job. See Section 3.3.4 for more detail.

The type of transfer mode for graphics to the printer is specified here. **Run Length Encoding** is the recommended transfer mode due to its high transfer rate. When using **Uncompressed 8-bit (Overwrite)**, or **Uncompressed 4-bit (Overwrite)**, the same output as **Run Length Encoding** can be obtained, but the data transfer speed slows down.

3.7.2 Print Density Adjustment

Notes:

The setting made in this section can be saved in the file as a preferred setting for a particular print job. See Section 3.3.4 for more detail.

Print density needs to be adjusted to avoid blurred or light print caused by a combination of the media with the ribbon.

Mark the **Set** Checkbox, and the print density for each color can be adjusted.

The print density value can be adjusted by entering a value or by clicking up or down arrows.

3.8 Device Settings

This section describes how to perform maintenance and printer testing. The **Device Settings** property page can help determine how well the computer is communicating with the printer and verify that certain settings are correct.

Click the **Device Settings** tab to open the **Device Settings** property page.

Note:

The “Error Writing to LPT1” message appears when trying to use the functions in the **Device Settings** property page without connecting the printer to your computer.

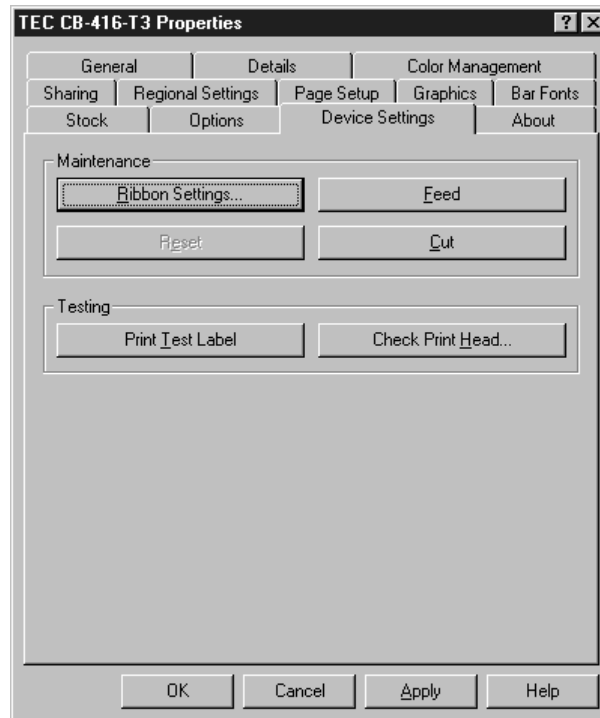

3.8.1 Maintenance

Ribbon Settings

Click **Ribbon Settings** to specify the type and width of the ribbon, as well as the ribbon motor voltage.

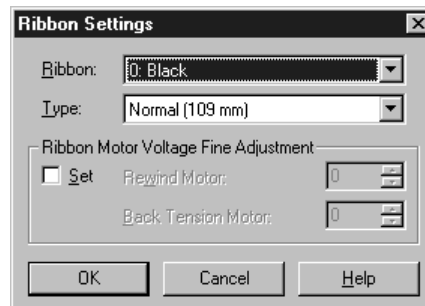

CAUTION!

Do not load a normal ribbon when specifying Premium for the type of ribbon, as this may cause the ribbon to be melted.

- In **Ribbon**, select the color that is loaded in the printer.
- Click the **Type** down arrow to select the type and width of ribbon to be used.
- In **Ribbon Motor Voltage Fine Adjustment**, mark the **Set** checkbox to make a fine adjustment for the rewind motor and the back tension motor voltage.

3.8.1 Maintenance (Cont.)

Please enter the proper value for the Ribbon Motor Voltage Fine Adjustment according to the table below.

No.	Ribbon Parts No	Set Values in Ribbon Settings					Remarks		
		Ribbon	Type	Ribbon Motor Voltage Fine Adjustment			Necessity of Cool Release Enhancement	Width (mm)	Available Media Width (mm)
				Set	Rewind Motor	Back Tension Motor			
Normal Ribbon									
1	BRCB109300-AB	0:Black	Normal (109)		0	0	No (Hot Release Ribbons)	109	85 to 110
2	BRCB109300-AM	1:Magenta							
3	BRCB109300-AC	2:Cyan							
4	BRCB109300-AY	3:Yellow							
5	BRCB088300-AB	0:Black	Normal (109)	x	-10 to -20	0	No (Hot Release Ribbons)	88	65 to 85
6	BRCB088300-AM	1:Magenta							
7	BRCB088300-AC	2:Cyan							
8	BRCB088300-AY	3:Yellow							
9	BRCB068300-AB	0:Black	Normal (68)	x	-15	-5	No (Hot Release Ribbons)	68	45 to 65
10	BRCB068300-AM	1:Magenta							
11	BRCB068300-AC	2:Cyan							
12	BRCB068300-AY	3:Yellow							
13	BRBLK109A3	0:Black	Premium (109)	x	-20	-10	Yes (Cold Release Ribbons)	109	85 to 110
14	BRMAG109A3	1:Magenta							
15	BRCYN109A3	2:Cyan							
16	BRYEL109A3	3:Yellow							
Super Premium Ribbon									
1	BRBLK109D4	0:Black	Premium (109)	x	-20	-10	Yes (Cold Release Ribbons)	109	85 to 110
2	BRMAG109D4	1:Magenta							
3	BRCYN109D4	2:Cyan							
4	BRYEL109D4	3:Yellow							
5	BRBLK088D4	0:Black	Premium (109)	x	-10 to -20	0	Yes (Cold Release Ribbons)	88	65 to 85
6	BRMAG088D4	1:Magenta							
7	BRCYN088D4	2:Cyan							
8	BRYEL088D4	3:Yellow							
9	BRBLK068D4	0:Black	Premium (68)	x	-20	-10	Yes (Cold Release Ribbons)	68	45 to 65
10	BRMAG068D4	1:Magenta							
11	BRCYN068D4	2:Cyan							
12	BRYEL068D4	3:Yellow							

Feed

Click **Feed** to advance the label or tag.

Reset

Reset is not available for this model.

Cut

Click **Cut** to feed and cut a label and tag.

3.8.2 Testing

Print Test Label

See *Section 3.9.1* for further information.

Check Print Head

Click **Check Print Head** to begin running the printer's built-in head test.

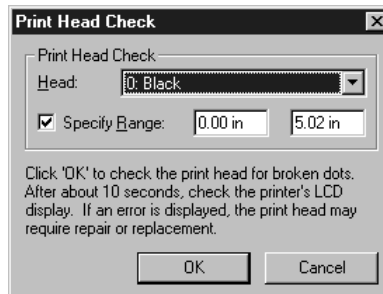

Click the **Head** down arrow to select the print head to check.

Mark the **Specify Range** checkbox to specify the range for the print head check.

Click **OK** to start checking the print head.

If there are problems with the print head, an error message will appear on the printer's Message Display, and the print head must be replaced right away.

3.9 Print Test

When the installation of the printer driver and settings of the printer properties are complete, perform a print test to verify that the printer is communicating with the computer, and that the properties are set correctly.

Before starting the print test, please make sure of the following:

- Printer is turned on.
- Interface cable is connected to the printer properly.
- Top Cover is closed.
- “ON LINE” is displayed on the printer’s Message Display.
- Media and ribbons are loaded properly.
- Sensor position is adjusted correctly according to the media loaded.
- Sensitivity of the media sensor is adjusted.

3.9.1 Procedures

There are two ways to perform the print test.

Click **Print Test Page** on the **General** property page.

or

Click **Print Test Label** on the **Device Settings** property page.

The print test sample will be printed out if the printer is communicating with the computer properly as follows:

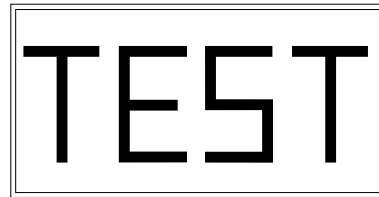

(Print Test Sample)

3.10 Printing a Label

To print a 4 x 4-label created using Microsoft® Word Pad, follow the instruction in this example.

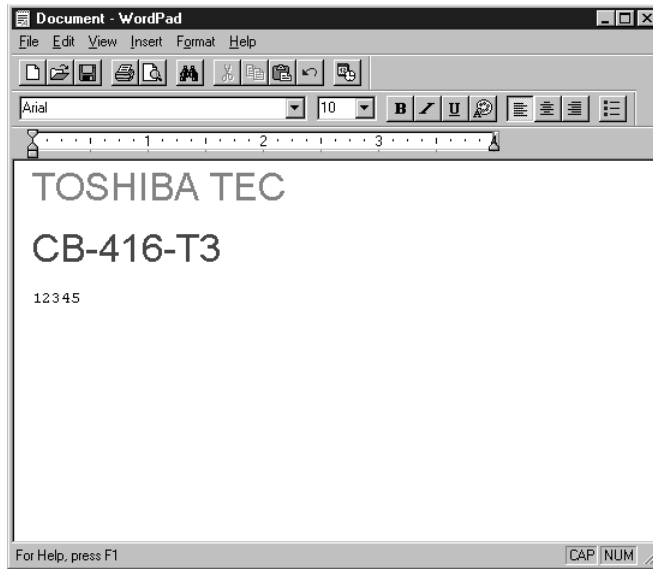

- 1 On the **File** menu, click **Print**.

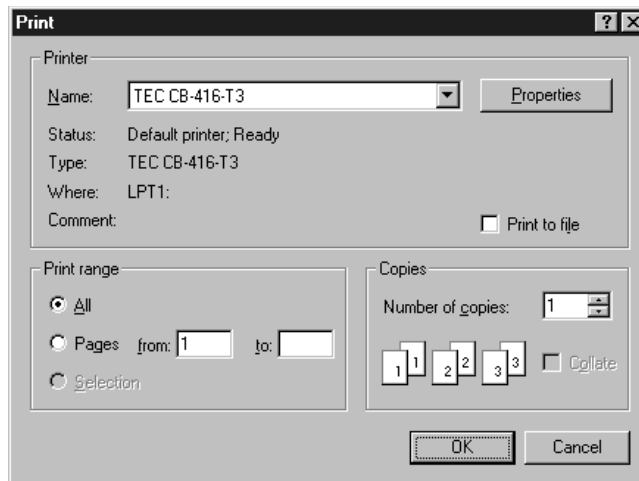

Note:
If another printer is selected, click the **Name** down arrow, and select the **CB-416-T3** printer.

- 2 Make sure that “**TEC CB-416-T3**” is selected in **Name**. Click **Properties**.

3.10 Printing a Label (Cont.)

Note:

Only five property pages are available in the application programs: Page Setup, Graphics, Stock, Options, and About.

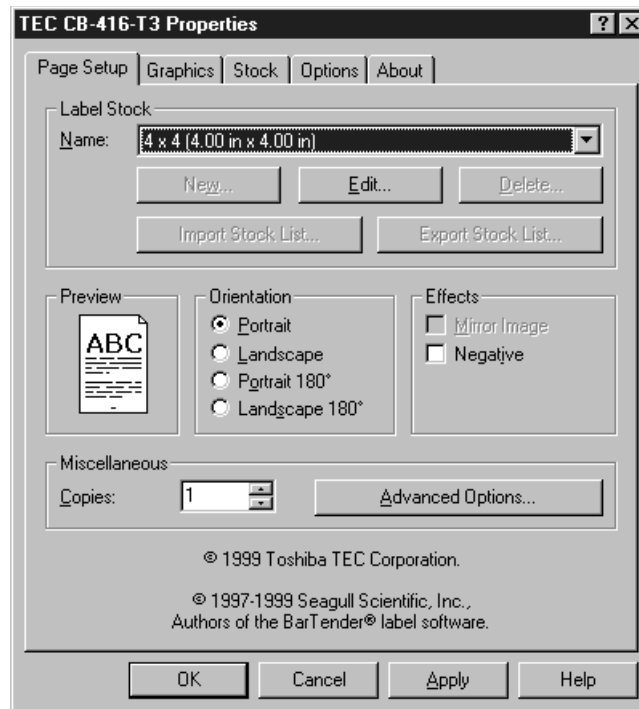

- 3 Be sure to check the following in each property page before printing:
 - Label size and orientation. See *Section 3.3* for more detail.
 - Dithering and intensity. See *Section 3.4* for more detail.
 - Print method, sensor, label gap, issue mode, print method, fine adjustment, and so on. See *Sections 3.6* for more detail.
 - Print density adjustment. See *Section 3.7* for more detail.

When finished checking the property pages, click **OK** to return to the **Print** dialog.

Note:

If the **ERROR LED** flashes or illuminates, and an error message appears on the printer's Message Display, an error has occurred. Please see *Chapter 6* to take the proper action.

- 4 Set **Print range** and **Number of copies**, and click **OK** to start printing the label.
 - The ON LINE LED flashes when the printer is communicating with your computer.
 - The ON LINE LED illuminates while printing.
- 5 This completes printing a sample label.

3.10 Printing a Label (Cont.)

Note:
In an application program, the fonts contained in the printer can be applied to text by specifying the printer fonts named "TEC XXXX"

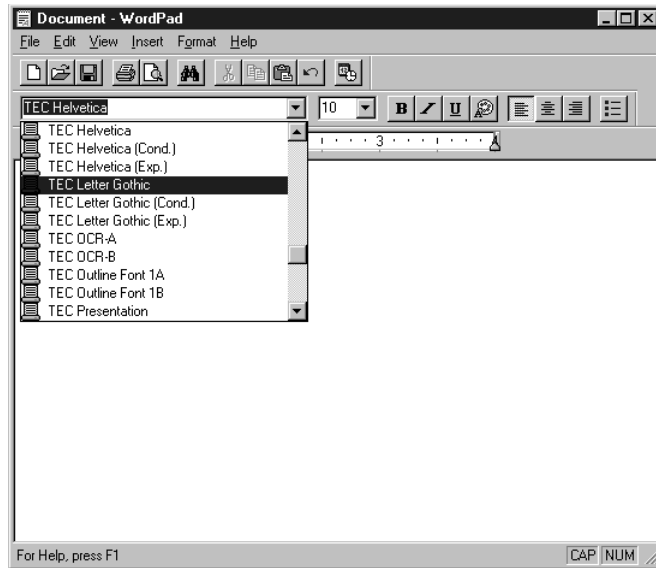

4. Online Mode

This chapter describes usage and purpose of the keys on the Operation Panel in Online Mode.

When the printer is in Online Mode and connected to a computer, normal operation of printing images on labels or tags can be accomplished.

4.1 Operation Panel

The figure below illustrates the Operation Panel and key functions.

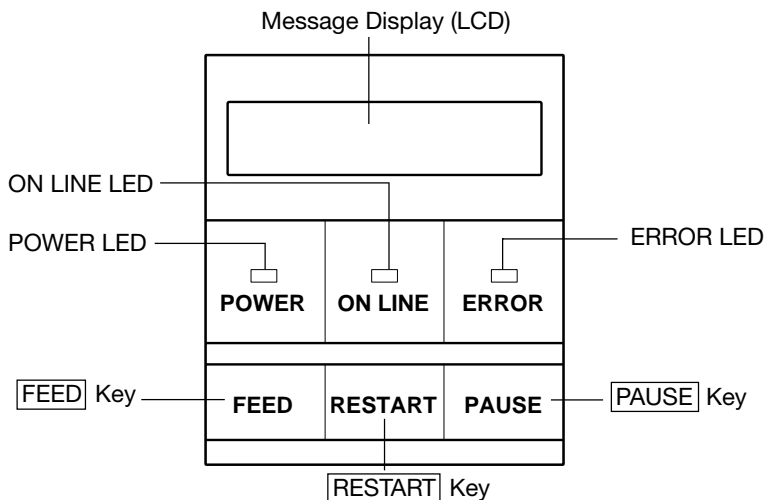

The Message Display shows messages in alphanumeric characters and symbols to indicate the printer's status. Up to 16 characters can be displayed on one line.

There are three LED's on the Operation Panel.

Note:
A near end condition is selected by the DIP Switch. See Appendix 2 for more detail.

LED	Illuminates when...	Flashes when...
POWER	The printer is turned on.	
ON LINE	The printer is ready to print.	The printer is communicating with your computer.
ERROR	Any error occurs with the printer.	The ribbon supply is low or in a near end condition.

There are three keys on the Operation Panel.

Note:
Use the **RESTART** key to resume printing after a pause condition, or after clearing an error.

PAUSE	To stop printing temporarily.
RESTART	To restart printing.
FEED	To feed the media.

4.2 Operation

When the printer is turned on, the “ON LINE” message appears on the Message Display. It is shown during standby or normal printing.

ON LINE

The printer is turned on, standing by, or printing.

NO PAPER

If any error occurs during printing, an error message appears. The printer stops printing automatically.

ON LINE

To clear the error, press the **RESTART** key. The printer resumes printing.

PAUSE

If the **PAUSE** key is pressed during printing, the printer stops printing temporarily.

ON LINE

When the **RESTART** key is pressed, the printer resumes printing.

4.3 Reset

Clears the print data that was sent to the printer from the computer, and has the printer return to an idle condition by the reset operation.

ON LINE

The printer is turned on, standing by, or printing.

PAUSE

To stop printing, or clear the data sent from the computer, press the **PAUSE** key. The printer stops printing.

ON LINE

Press the **RESTART** key for 3 seconds or longer. The data that was sent from the computer will be cleared, and the printer returns to an idle condition.

Note:

*If the **RESTART** key is held for less than 3 seconds when the printer is in an error or pause state, the printer restarts printing. However, when a communication error or command error occurs, the printer returns to an idle condition.*

5. Maintenance

This chapter describes how to perform normal maintenance. To maintain the printer performance and quality print, please clean the printer regularly, or whenever media or ribbons are replaced.

CAUTION!

- *Be sure to disconnect the power cord before performing maintenance, as this may cause an electric shock.*
- *The print heads may become hot. Do not touch the print head.*
- *Do not pour water directly onto the printer.*

5.1 Cleaning

5.1.1 Print Head/Platen

CAUTION!

- *Do not allow any hard objects to contact the print head or platen, as this may cause damage to them.*
- *Do not use any volatile solvent including thinner and benzene, as this may cause discoloration of the cover, print failure, or breakdown of the printer.*
- *Do not touch the print head element with bare hands, as static may damage the print head.*

The following sections describe periodic cleaning of the unit.

- 1 Turn off the printer. Open the Top Cover.
- 2 Turn the Head Lever to the OPEN position. Remove the Ribbon Module from the printer.
- 3 Lift the print head block.
- 4 Clean the print head element using the supplied Thermal Head Cleaner.

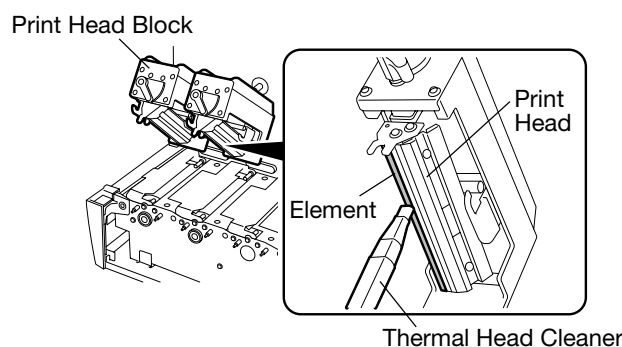

- 5 Lift the near side of the Guide Plate. Pull and remove it from the Platen.
- 6 Wipe the Platen with a soft cloth moistened with ethyl alcohol.

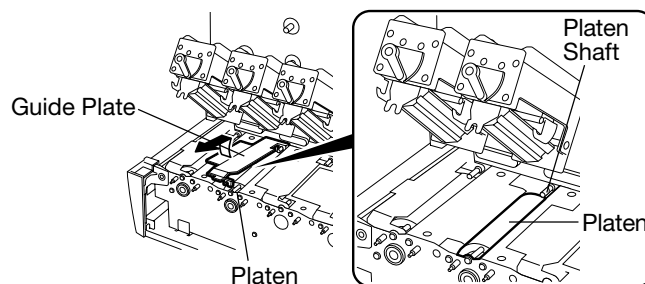

Note:

When reinstalling the Guide Plate, place the end of the Guide Plate on the Platen Shaft, and slide it into the end. Then fit the front of the Guide Plate into the Platen Shaft.

5.1.2 Pinch Roller/Feed Roller/Media Guide

Caution!

Do not use the supplied Feed Roller Brush except for cleaning the Feed Roller, as it is a metal brush.

Note:

As a guide, please clean the Feed Roller every 100km of the printing distance.

- 1 Turn off the printer. Open the Top Cover.
- 2 Turn the Pinch Roller Lever to the ROLLER RELEASE position to open the Pinch Roller Unit. Remove the loaded media from the printer.
- 3 Wipe the Pinch Roller and Media Guides with a soft cloth moistened with ethyl alcohol.
- 4 Clean the Feed Roller using the supplied Feed Roller Brush.

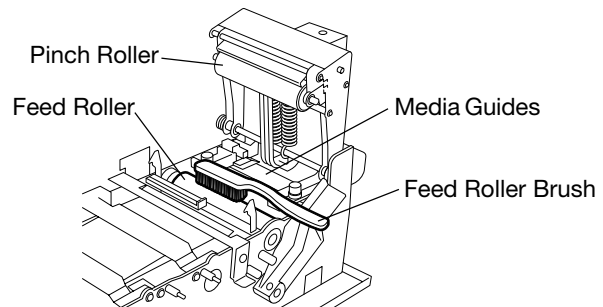

5.1.3 Fan Filters

- 1 Turn off the printer. Unplug the power cord.
- 2 Remove the Fan Filters.

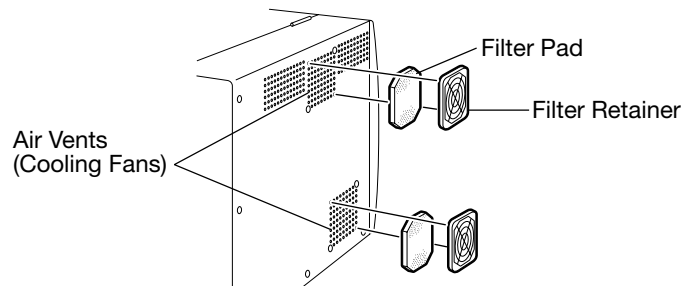

- 3 Wash the Fan Pads with a neutral detergent. Then squeeze the detergent out of the Filter Pads, and dry them well.

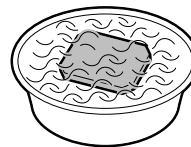

- 4 Reinstall the Fan Filters in the reverse order of removal. See Section 2.1.1 for more detail.

CAUTION!

Reinstall the Fan Filters after drying them completely, as this may rust the Fan Retainer or cause a breakdown of the printer.

5.1.4 Covers and Panels

Wipe the cover or front panel with a dry and soft cloth. Wipe dirt with a soft cloth moistened with a little water.

CAUTION!
Do not use any volatile solvent including thinner and benzene, as this may cause discoloration or distortion of the cover.

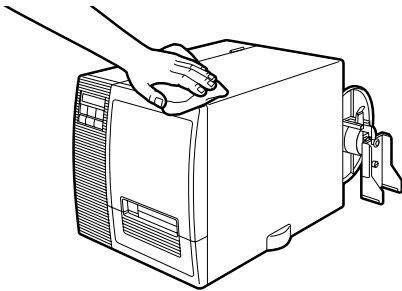

5.1.5 Ribbon Modules

Wipe anywhere the ribbon touches the ribbon module with a dry and soft cloth.

Front

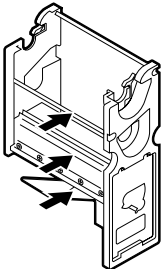

Rear

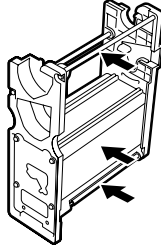

6. Troubleshooting

This chapter lists the error messages or possible problems and their solutions.

Important!

If a problem cannot be solved by taking actions described in this chapter, do not attempt to repair the printer. Turn off and unplug the printer. Then contact an authorized service representative for assistance.

6.1 Error Messages

Notes:

- If an error is not cleared by pressing the **RESTART** key, turn the printer off and then on.
- After the printer is turned off, all print data in the printer is cleared.
- “####” indicates remaining label count up to 9999 (in pieces).
- “*” indicates which color print head has a problem, as follows:
C: Cyan
Y: Yellow
M: Magenta
K: Black

Error Messages	Problems/Causes	Solutions
HEAD OPEN *	The print head block was opened in Online Mode.	Close the print head block. Then press the RESTART key.
HEAD OPEN ####*	Feed or printing has been attempted with the print head block open.	Close the print head block. Then press the RESTART key.
COMMS ERROR	A communication error has occurred.	Make sure the interface cable is firmly connected to the computer, and the computer is turned on.
PAPER JAM ####	<p>1 The media is jammed at the media path. The media is not fed smoothly.</p> <p>2 A wrong media sensor is selected for the media that is loaded.</p> <p>3 The Black Mark Sensor is not aligned to the black mark on the media.</p> <p>4 Size of the loaded media is not consistent with the programmed size.</p> <p>5 The Feed Gap Sensor cannot distinguish the print area from a label gap.</p>	<p>1 Remove the jammed media, and clean the Platen, Feed Roller and Pinch Roller. Then reload the media properly. Finally press the RESTART key.</p> <p>2 Turn the printer off and then on. Then select the media sensor supporting the media that is loaded. Finally resend the print job.</p> <p>3 Adjust the sensor position. Then press the RESTART key.</p> <p>4 Turn the printer off and then on. Replace the loaded media to match the programmed size, or select a programmed size that matches the loaded media. Finally resend the print job.</p> <p>5 Adjust sensitivity of the media sensor. If this does not solve the problem, turn off the printer, and call an authorized service representative.</p>

Error Messages	Problems/Causes	Solutions
CUTTER ERROR#### (Only when the Cutter Module is installed on the printer)	The media is jammed at the cutter.	Remove the jammed media. Then press the RESTART key. If this does not solve the problem, turn off the printer, and call an authorized service representative.
NO PAPER ####	1 The media runs out. 2 The media is not loaded properly. 3 The Supply Shaft is rotating in the wrong direction. 4 The media is slack.	1 Load new media. Then press the RESTART key. 2 Load the media properly. Then press the RESTART key. 3 Switch to the right Back Tension Selector. 4 Take up any slack in the media.
RIBBON ERR.#####*	The ribbon is not fed successfully.	Remove the Ribbon Module, and check status of the ribbon. Replace the ribbon, if necessary. If the problem is not solved, turn off the printer, and call an authorized service representative.
EXCESS HEAD TEMP	The print head is overheated.	Turn off the printer, and allow it to cool down (about 3 minutes). If this does not solve the problem, call an authorized service representative.
COVER OPEN	The Top Cover was opened in Online Mode.	Close the Top Cover. Then press the RESTART key.
COVER OPEN ####	Feed or printing has been attempted with the Top Cover open.	Close the Top Cover. Then press the RESTART key.
PAPER SET ERROR	The Pinch Roller Unit is not released in Online Mode.	Lock the Pinch Roller Unit properly. Then press the RESTART key.
PAPER ERROR #####	While feeding or printing, the Pinch Roller Unit became unlocked.	Lock the Pinch Roller Unit properly. Then press the RESTART key.
EXCESS P/S TEMP	The power supply unit is overheated.	Turn off the printer, and allow it to cool down (about 3 minutes). If this does not solve the problem, call an authorized service representative.
NO RIBBON #####*	The ribbon has run out.	Load a new ribbon. Then press the RESTART key.
HEAD ERROR *	There is a problem with the print head.	Replace the print head. Then press the RESTART key.
Other Error Messages	Hardware or software problems may have occurred.	Turn the printer off and then on. If this does not solve the problem, turn off the printer again, and call an authorized service representative.

6.2 Possible Problems

This section describes problems that may occur when using the printer, and their causes and solutions.

Possible Problems	Causes	Solutions
The printer will not turn on.	<ol style="list-style-type: none"> 1 The power cord is disconnected. 2 The AC outlet is not functioning correctly. 3 The fuse has blown, or the circuit breaker has tripped. 	<ol style="list-style-type: none"> 1 Plug in the power cord. 2 Make sure that power is supplied using another electric appliance. 3 Check the fuse or breaker.
The media is not feeding.	<ol style="list-style-type: none"> 1 The media is not loaded properly. 2 The printer is in an error condition. 	<ol style="list-style-type: none"> 1 Load the media properly. 2 Resolve the error in the Message Display. (See Section 6.1 for more detail.)
Nothing is printed on the media.	<ol style="list-style-type: none"> 1 The media is not loaded properly. 2 The ribbon is not loaded properly. 3 A print head is not installed properly. 4 The ribbon and media are not matched. 5 The print density fine adjustment value is too low. 	<ol style="list-style-type: none"> 1 Load the media properly. 2 Load the ribbon properly. 3 Install the printer head properly. Secure the print head by turning the Head Lever to the LOCK position 4 Select an appropriate ribbon for the media type used. 5 Increase the print density fine adjustment value.
The printed image is blurred.	<ol style="list-style-type: none"> 1 The ribbon and media are not matched. 2 The print head is not cleaned. 	<ol style="list-style-type: none"> 1 Select an appropriate ribbon for the media type used. 2 Clean the print head using the supplied Thermal Head Cleaner.
A streak appears on the printed image.	<ol style="list-style-type: none"> 1 The print head is not cleaned. 2 There is a problem with the print head. 	In System Mode, print out the slant line patterns for all four colors. Then perform the print head check. If the check is successful, just clean the print head. If any problem is detected, replace the print head.

6.3 Removing Jammed Media

This section describes in detail how to remove jammed media from the printer.

6.3.1 From the Pinch Roller Unit

Remove the jammed media from the Pinch Roller Unit as follows:

- 1 Open the Top Cover.
- 2 Lift the Pinch Roller Lever to the ROLLER RELEASE position to open the Pinch Roller Unit.
- 3 Pull out the Media Pressure Plate, and remove the jammed media.

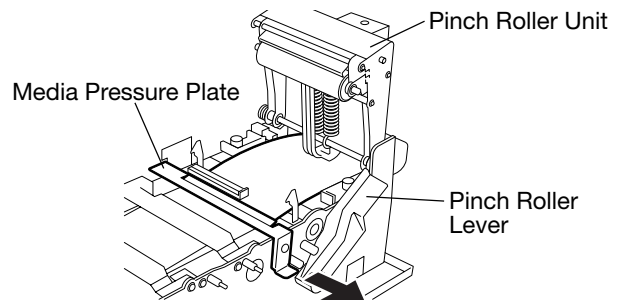

- 4 Clean the Pinch Roller Unit as described in *Section 5.1.2*.

6.3.2 From the Print Head Block

Remove the jammed media from the print head block as follows:

CAUTION!
 Do not scratch the print head or platen using any sharp tool, as this may cause media feed failure or breakdown of the printer.

- 1 Open the Top Cover.
- 2 Turn the Head Levers to the OPEN position. Remove the Ribbon Modules.
- 3 Lift the print head blocks.
- 4 Remove the Guide Plates. Then remove the jammed media.

Note:
 See *Section 5.1.1* for more detail for removing the Guide Plates.

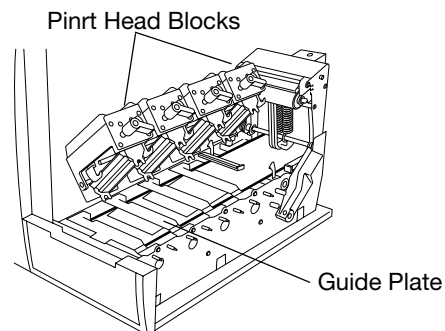

- 5 Clean the print head blocks using the Thermal Head Cleaner, as described in *Section 5.1.1*.

6.4 When the Ribbon is Torn Apart

This is a quick-fix procedure just in case the ribbon is torn apart in the middle of printing.

- 1 Turn the printer off. Unplug the power cord. Open the Top Cover.
- 2 Turn the Head Lever to the OPEN position. Remove the Ribbon Module containing the torn ribbon.
- 3 Remove the ribbon torn from the Ribbon Module.
- 4 Cut the torn parts off straight.

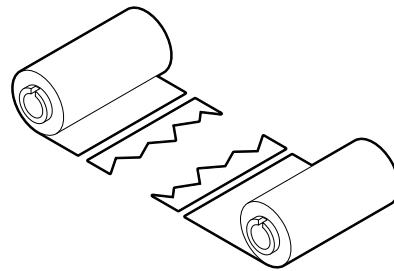

- 5 Align the torn ribbon carefully, and place a piece of tape completely across both cut ends.

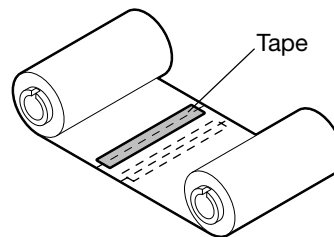

- 6 Reload the ribbon in the Ribbon Module.
- 7 Wind the ribbon by hand a few times so that the torn part is not used for printing.

Appendix 1 Specifications

Appendix 1 describes the printer specifications and supplies for use on the CB-416-T3 color printer.

A1.1 Printer

This is the printer specification.

Item	Model	CB-416-T3-QQ
Supply voltage		100 to 120V +10% 50/60Hz
Power consumption		3.5A, 300W maximum during a print job 360mA, 30W maximum during standby
Operating temperature range		40°F to 104°F (5°C to 40°C)
Relative humidity		25% to 85% RH (no condensation)
Print head density		305dpi (12 dots/mm)
Printing method		Thermal transfer
Print speed		<ul style="list-style-type: none"> • 4 inches/sec. (101.6mm/sec.) • 6 inches/sec. (152.4mm/sec.)
Available media width (including backing paper)		2 in. to 4.4 in (50mm to 110mm)
Effective print width (max.)		4 in. (100.0mm)
Issue mode		<ul style="list-style-type: none"> • Batch (with back feed) • Batch (no back feed) • Cut (Cut Mode is enabled only when the Cutter Module is installed.)
Message display		16 characters/line
Ribbon color		<ul style="list-style-type: none"> • Basic colors (Y: Yellow, C: Cyan, M: Magenta, K: Black) • Spot colors
Dimension		13.7 in. (W) x 20.4 in. (D)* x 15.1 in. (H) (350mm (W) x 520mm (D)* x 385mm (H)) * 320 in. (800mm) when the Supply Shaft Holder is installed.
Weight		About 88lb (40kg) (Media and ribbons are not included.)
Available print font		Times Roman, Helvetica, Letter Gothic, Prestige Elite, Courier, Presentation, OCR-A, OCR-B, Outline
Available bar font		JAN, EAN, UPC, NW-7, CODE39/93/128/, MSI, Industrial 2 of 5, Data Matrix™, PDF417™, QR code
Rotations		0°, 90°, 180°, 270°
Standard interface		<ul style="list-style-type: none"> • Serial interface (RS-232C) • Parallel interface (Centronics) ECP Mode • Expansion I/O interface

Notes:

- *Data Matrix™*, is a trademark of International Data Matrix Inc., U.S.
- *PDF417™* is a trademark of Symbol Technologies Inc., US.
- *QR Code* is a trademark of DENSO CORPORATION.

A1.2 Options

Name	Model	Description
Cutter Module	CB-1204-QM	Rotary cutter for cutting media without stopping
Ribbon Module	CB-1004-QM	Spare ribbon module

A1.3 Media

Please make sure that the media that will be used is approved by TOSHIBA TEC. The warranty does not apply when a problem is caused by using media that is not approved by TOSHIBA TEC. For information regarding TOSHIBA TEC-approved media, please contact an authorized service representative.

A1.3.1 Media Type

Two types of media can be loaded for this thermal transfer printer—label or tag. The table below shows size and shape of the media available for this printer.

Note:

- Labels are rolled outside, and tags are rolled inside. Whichever media you use, load it with print side facing up.

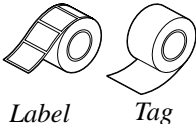

Label
Tag

- The label length (pitch) will be 1300 mm if a SIMM is added to the printer.

	Label	Tag
Paper Width	50.4 to 110 mm	50.4 to 110 mm
Length (Pitch)	10 to 1050 (1300) mm	10 to 999 mm
Thickness	130 to 170 μm	100 to 290 μm
Max. Roll Diameter	φ230 mm	
Winding Method	Rolled outside	Rolled inside
Paper Core	ID φ76.2 mm ± 0.3 as standard	

- The ratio “Label length” to “Gap length” must be 3:1 or more.
- In Cut Mode, the minimum “Pitch” must be 30 mm or more.
- The paper width for the label includes its backing paper.
- As backing paper, glassine 7K blue or equivalent must be used. (The backing paper to be used must have a transmission factor of 22% or higher.)
- In Cut Mode, the cut should not be performed on the label, but on the gap between labels. When labels with perforation are used, it is necessary to test and confirm the cutting performance thoroughly beforehand.
- The gap length must be 6 mm or more, and the cut position must be adjusted so that the cutter cuts in the center of the gap.

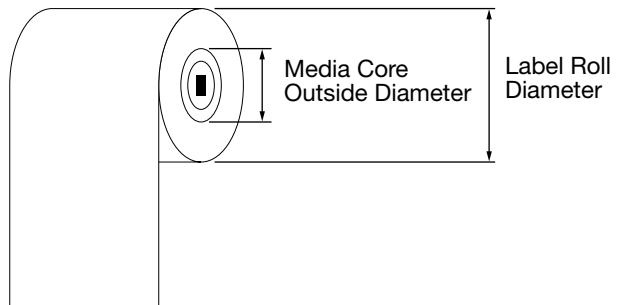

A1.3.1 Media Type (Cont.)

The formula below shows the relation between paper roll length and paper core diameter.

$$L = \frac{(D^2 - d^2) \pi}{4 t}$$

- L : Paper length
- D : Paper roll diameter
- d : Paper core outside diameter
- t : Paper thickness
- ($\pi = 3.14\dots$)

For calculation, the units of the factors must be the same.

A1.3.2 Detection Area of the Transmissive Sensor

The Transmissive Sensor is movable from the center to the left edge of media.

The Transmissive Sensor detects a gap between labels, as illustrated below.

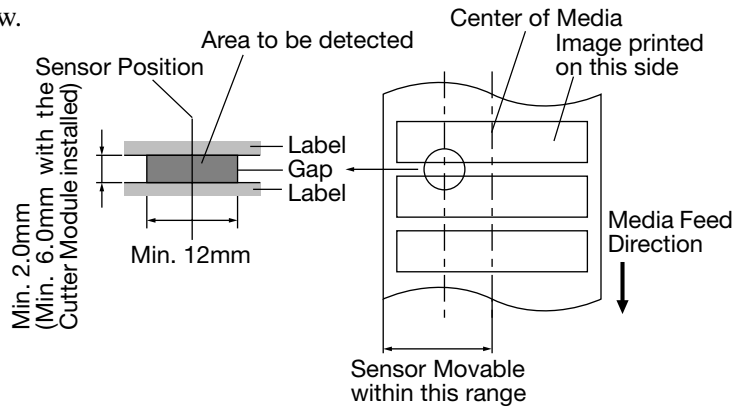

The Transmissive Sensor detects a hole on a roll of tags, as illustrated below.

Note:
This printer does not support a roll of tags with round holes.

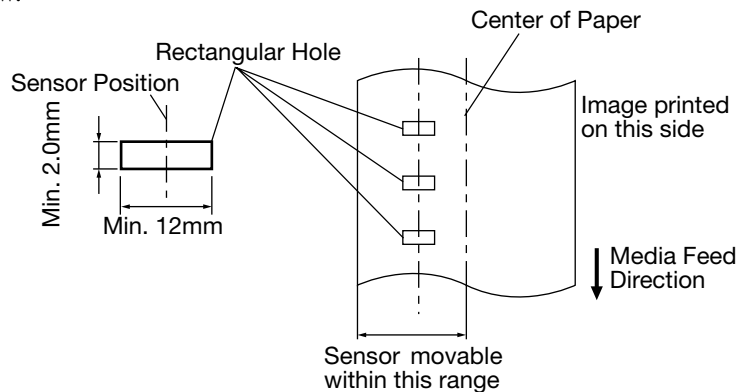

A1.3.3 Detection Area of the Reflective Sensor

The Reflective Sensor is movable from the left edge to the center of media.

The reflection factor of the black mark must be 10% or lower with a waveform length of 950 nm.

The Reflective Sensor should be aligned to the center of the black mark.

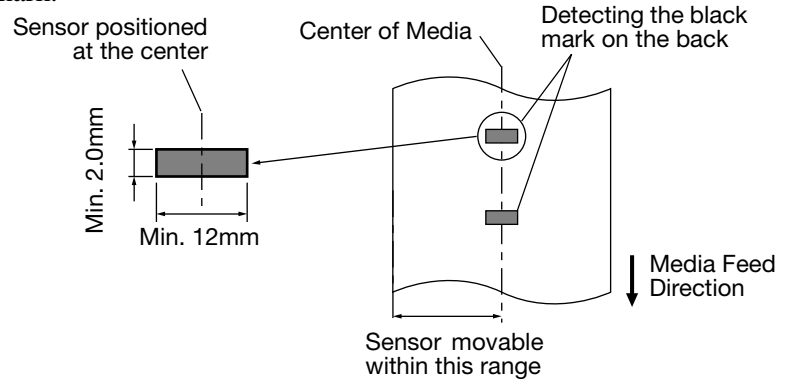

A1.3.4 Effective Print Area

The figure below illustrates the relation between head effective print width and media width (when the four print heads are center-aligned in the X direction).

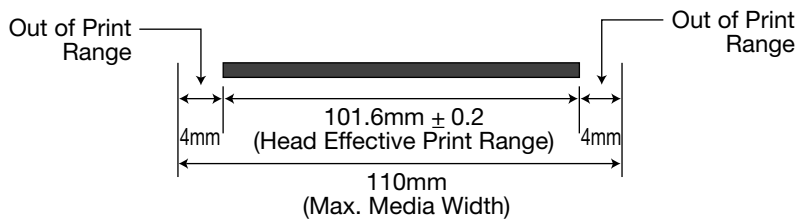

The figure below shows you the effective print area on the media.

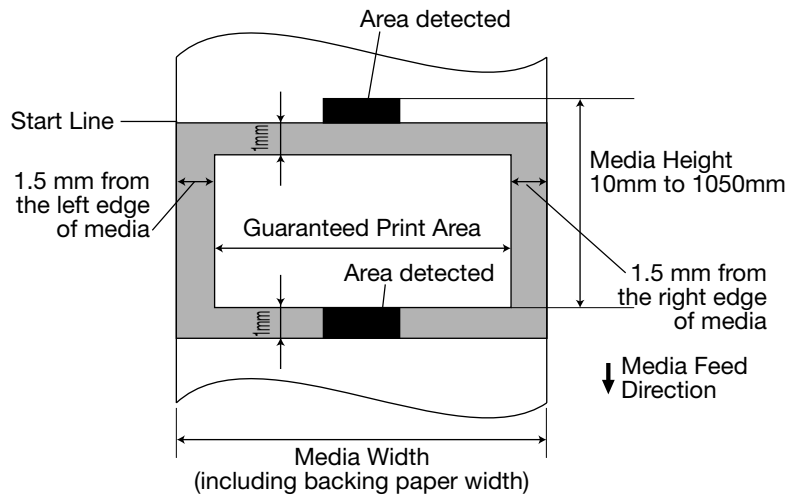

Notes:

- Printing quality in the shaded area is not guaranteed.
- Printing quality in the 1-mm width area around the media is not guaranteed in addition to the shaded area.
- The center of media is positioned at the center of the print heads.
- Printing outside of the effective print area may cause print failure even on the guaranteed print area.
- If a roll of tags has rectangular holes, print quality in the 1-mm width around the hole is not guaranteed.

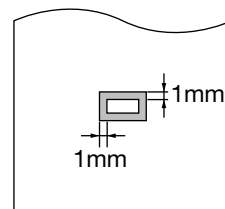

A1.4 Ribbon

Please make sure that the ribbon will be used is approved by TOSHIBA TEC. The warranty does not apply to any problem caused by using non-approved ribbons.
 For information regarding TOSHIBA TEC-approved ribbon, please contact a sales representative.

Type	Spool Type
Width	68mm, 88mm, and 109mm
Length	300m
Outside Diameter	φ 67mm (max.)

The table below shows you the correlation between ribbon width and media width (backing paper not included).

Ribbon Width	Media Width
68mm	50 to 65 mm
88mm	65 to 85mm
109mm	85 to 110mm

Appendix 2 DIP Switches

Appendix 2 describes functions of the DIP switches. The DIP switches are used to change a printer specification.

CAUTION!

Please turn off the printer when changing the DIP switch settings, as this may cause an electric shock.

To enable a new specification, please turn the printer off and then on.

The DIP switches A and B are located on the rear of the printer, as illustrated below.

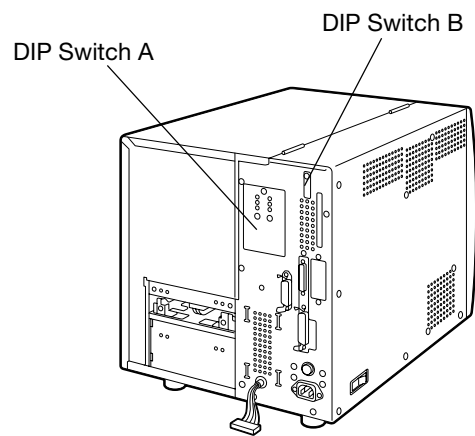

A2.1 DIP Switch A

- Notes:*
- The shaded areas are the factory default settings.
“OFF” means “OPEN”.
 - See A2.3 for further information about the ribbon near end detection.

No.	ON/OFF			Function
1	OFF			Must be set to OFF
	ON			
2	OFF			Cutter Module
	ON			
3	OFF			Must be set to OFF
	ON			
4	4	5		Ribbon near end detected.
	OFF	OFF		
	ON	OFF		
	OFF	ON		
5	ON	ON		Ribbon near end detected.
	OFF	ON		
	ON	ON		
6	6	7	8	Language to display LCD error message
	OFF	OFF	OFF	
	ON	OFF	OFF	
	OFF	ON	OFF	
	ON	ON	OFF	
	OFF	OFF	ON	
	ON	OFF	ON	
	OFF	ON	ON	
ON	ON	ON		

A2.2 DIP Switch B

Note:
The shaded areas are the factory default settings.
“OFF” means “OPEN”.

No.	ON/OFF		Function
	1	2	
1	OFF	OFF	2400 BPS
	ON	OFF	4800 BPS
2	OFF	ON	9600 BPS
	ON	ON	19200 BPS
3	OFF		1 bit
	ON		2 bits
4	OFF		7 bits
	ON		8 bits
5	OFF		Without
	ON		With
6	OFF		EVEN
	ON		ODD
7		7	8
	OFF	OFF	XON/XOFF (No XON is output at the power on time) (No XOFF is output at the power off time.)
	ON	OFF	READY/BUSY (DTA) (No XON is output at the power on time) (No XOFF is output at the power of time)
	OFF	ON	XON/XOFF+READY/BUSY (XON is output at the power on time) (XOFF is output at the power of time)
8	ON	ON	XON/XOFF (XON is output at the power on time.) (XOFF is output at the power off time.)

A2.3 Ribbon Near End Detection

This section gives you additional information regarding ribbon near end detection.

- The printer detects that the ribbon is about to run out, when 10 ± 7 m of ribbon is remaining.
- When the ribbon is about to run out, the ERROR LED flashes. When replacing the ribbon, the printer resumes printing. Then the ERROR LED is turned off. When replacing one ribbon, if there is another ribbon that is about to run out, the ERROR LED remains flashing.
- Switches in DIP Switch A can be changed to specify how the printer operates when the ribbon is about to run out.
 - 1 When detecting that the ribbon is about to run out, the ERROR LED flashes, and the printer stops printing temporarily, as if the **PAUSE** key were pressed. Press the **RESTART** key to resume printing.
 - 2 When detecting that the ribbon is about to run out, the ERROR LED flashes. However the printer does not stop printing until the ribbon runs out completely or finishes the print job.
- While the ERROR LED is indicating that one ribbon is about to run out, the printer does not detect that another ribbon is almost running out.
- When using Ribbon Save Mode, the printer cannot detect that the ribbon is about to run out, unless the ribbon advances over 50mm.

Appendix 3 Quick Reference for Printing

The tables below outline the actions necessary to modify the printer settings.

1 Label Settings

Actions	Path to Find the Property Page	See Section...
Enter a name of label stock.	Page Setup (TAB) → New (Button) → Edit Label Stock	3.3.2
Specify label size (including width and length).	Page Setup (TAB) → New (Button) → Edit Label Stock	3.3.2
Specify an amount of space between labels.	Stock (TAB) → Label Gap	3.6.3
Select the media sensor.	Stock (TAB) → Sensor	3.6.2
Make a fine adjustment (including feed or back feed amount and cut position).	Stock (TAB) → Fine Adjustment	3.6.5
Adjust print density.	Options (TAB) → Print Density Adjustment → Set (Checkbox)	3.7.2
Align colors.	Graphics (TAB) → Color Registration (Button) → Align All Colors (Button)	3.4.4
Specify the type of ribbon to be used.	Device Settings (TAB) → Ribbon Settings (Button) → Ribbon → Type	3.8.1
Adjust the Ribbon Motor Voltage.	Device Settings (TAB) → Ribbon Settings (Button) → Ribbon Motor Voltage Fine Adjustment → Set (Checkbox).	3.8.1

2 Issue Mode Settings

Actions	Path to Find the Property Page	See Section...
Specify the orientation.	Page Setup (TAB) → Orientation	3.3.3
Specify the print speed.	Stock (TAB) → Print Speed (in Issue Settings)	3.6.4
Specify either process color printing (CMY/CMYK) or spot color printing.	Graphics (TAB) → Spot Color Setup (Button)	3.4.5
Specify the type of Ribbon Save.	Stock (TAB) → Print Method (in Media Settings)	3.6.1
Specify a cut interval.	Stock (TAB) → Cut (in Issue Settings)	3.6.4
Specify whether to perform back feed.	Stock (TAB) → Issue Mode (in Issue Settings)	3.6.4
Select the dithering pattern.	Graphics (TAB) → Dithering	3.4.1
Specify tone (RGB).	Graphics (TAB) → Intensity	3.4.2
Specify colors for the spot color printing.	Graphics (TAB) → Spot Color Setup (Button) → Color Model	3.4.5

3 Other Settings

Actions	Path to the Property Page	See Section...
Select the graphics transfer mode.	Options (TAB) → Transfer Mode (in Graphic Options)	3.7.1
Feed labels/tags.	Device Settings (TAB) → Feed (Button)	3.8.1
Cut labels/tags.	Device Settings (TAB) → Cut (Button)	3.8.1
Check if there is any problem with the print head.	Device Settings (TAB) → Check Print Head (Button)	3.8.2
View the license information.	About (TAB) → License (Button)	
View the printer driver information.	About (TAB) → Version (Button)	
Select the language to display.	Regional Settings (TAB) → Language (in Language Selection)	
Select the measuring unit.	Regional Settings (TAB) → Units (in Measurement System)	
Specify the User Commands.	Page Setup (TAB) → Advanced Options (Button) → User Commands	3.3.4
Use the Line Command.	Page Setup (TAB) → Advanced Options (Button) → Device Lines	3.3.4
Specify bar code settings.	Bar Fonts (TAB) → New (Button) → Edit Bar Code Font	3.5.1

The table below summarizes the tabs and functions available for the printer.

TAB	Function	See Section...	Remarks
General	Display the printer name.		Please refer to the user's manual of your computer.
	Type and display the comment.		
	Specify the separator page.		
	Perform the test print.		
Details	Display the printer name.		Please refer to the user's manual of your computer.
	Specify the output port.		
	Select the printer driver to be used.		
	Make the timeout settings.		
	Make the spool settings.		
	Make the port settings.		
Color Management			
Stock	Specify the type of Ribbon Save.	3.6.1	
	Select the media sensor to be used.	3.6.2	
	Specify an amount of space between labels.	3.6.3	
	Specify whether to perform back feed in the Issue Mode.	3.6.4	The Cutter Module required.
	Enable the cutter option and specify a cut interval.	3.6.4	
	Specify the print speed.	3.6.4	
	Make a fine adjustment (including feed or back feed amount and cut position).	3.6.5	
Options	Select the graphics transfer mode.	3.7.1	
	Adjust print density.	3.7.2	
Device Settings	Specify a type of ribbon to be used.	3.8.1	
	Adjust the Ribbon Motor Voltage.	3.8.1	
	Feed labels or tags.	3.8.1	
	Cut labels or tags.	3.8.1	The Cutter Module required.
	Perform the test print.	3.8.2	
	Check if there is any problem with the print head.	3.8.2	
About	View the license information.		
	View the printer driver information.		
Sharing	Make the Sharing Settings.		Please refer to the user's manual of your computer.
Regional Setting	Select the language to be displayed.		
	Select the measuring unit.		
Page Setup	Specify the label stock (only Label Size).	3.3.1 & 3.3.2	
	Select the orientation (tag rotation).	3.3.3	
	Specify the number of copies to be printed out.	3.3.4	
	Specify the User Command.	3.3.4	
	Specify the device lines. (The Line Command is used.)	3.3.4	
Graphics	Select the dithering pattern.	3.4.1	
	Specify tone (RGB).	3.4.2	
	Specify whether to print in color or monochrome.	3.4.3	
	Perform color registration (alignment).	3.4.4	
	Select the color method (process/spot color)	3.4.5	
	Specify the color for the spot color printing.	3.4.6	
Bar Fonts	Specifying bar code font settings.	3.5.1	

Appendix 4 Message and LED

Appendix 4 describes the messages displayed on the Operation Panel.

Symbols in the Message

- 1 ○ : The LED illuminates. ⊙ : The LED is flashing. ● : The LED is turned Off.
- 2 #####: Remaining label count Up to 9999 (in pieces)
- 3 %%%: Remaining memory capacity for storing writable characters and logos 0 ~ 715 (in K bytes)
- 4 *: Print head block that has a problem.
K: Black Y: Yellow C: Cyan M: Magenta

No.	LCD Messages	LED Indication			Printer Status	Restoration by RESTART key Yes/No	Acceptance of Status Request Reset Command Yes/No
		POWER	ONLINE	ERROR			
1	ON LINE	○	○	●	In Online Mode	-	YES
	ON LINE	○	⊙	●	In Online Mode (The printer in communication)	-	YES
2	HEAD OPEN *	○	●	●	The print head was opened in Online Mode.	-	YES
3	PAUSE	○	●	●	The printer is paused.	YES	YES
4	COMMS ERROR	○	●	○	A parity error, overrun error or framing error has occurred during communication through RS-232C.	YES	YES
5	PAPER JAM #####	○	●	○	The media is jammed during paper feed.	YES	YES
6	CUTTER ERROR#####	○	●	○	A problem has occurred at the Cutter Module.	YES	YES
7	NO PAPER #####	○	●	○	The media has run out, or the media is not loaded on the Supply Shaft Holder properly.	YES	YES
8	RIBBON ERR.#####*	○	●	○	The ribbon has run out, or has been torn. A problem has occurred with the sensor that determines the torque for the ribbon motor.	YES	YES
	HEAD OPEN #####*	○	●	○	Feed or printing was attempted with the print head open.	YES	YES
10	EXCESS HEAD TEMP	○	●	○	The print head is overheated.	NO	YES
11	COVER OPEN	○	●	●	The cover was opened in Online Mode.	YES	YES
12	COVER OPEN #####	○	●	○	Feed or printing was attempted with the print head open.	YES	YES
13	PAPER SET ERROR	○	●	●	The Pinch Roller Unit is not locked in Online Mode.	YES	YES
14	PAPER ERROR #####	○	●	○	Feed or printing was attempted with the Pinch Roller Unit unlocked.	YES	YES
15	EXCESS P/S TEMP	○	●	○	The power supply unit is overheated.	NO	YES
16	SAVING %%%	○	○	●	In writable character or logo save mode	-	YES

No.	LCD Messages	LED Indication			Printer Status	Restoration by RESTART key Yes/No	Acceptance of Status Request Reset Command Yes/No
		POWER	ONLINE	ERROR			
17	FLASH WRITE ERR.	○	●	○	An error has occurred while writing to flash memory	NO	YES
18	FORMAT ERROR	○	●	○	An erase error has occurred in formatting the flash memory.	NO	YES
19	FLASH CARD FULL	○	●	○	Data cannot be stored because the flash memory is full.	NO	YES
20	NO RIBBON #####*	○	●	○	The ribbon has run out.	YES	YES
21	HEAD ERROR *	○	●	○	There is a problem with the print head.	YES	YES
22	STACK OVERFLOW	○	●	○	The Stacker is full.	YES	YES
23	STACKER ERROR	○	●	○	Printing was attempted with the Stacker turned OFF.	YES	YES
24	Display of error message (See Notes.)	○	●	○	A command error has occurred in analyzing the command.	YES	YES

Notes:

- If a command error is found in the command received, 16 bytes of the command error, starting from the command code, will be displayed. (However, [LF] and [NUL] will not be displayed.)

Example 1

[ESC] T20 E60 [LF] [NUL]

└── Command error

The following message appears.

T20E60

Example 2

[ESC] XR; 0200, 0300, 0450, 1200, 1 [LF] [NUL]

└── Command error

The following message appears.

XR;0200,0300,045

- When the error command is shown, “? (3FH)” appears for codes other than codes 20H to 7FH and A0H to DFH.

Appendix 5 System Mode

Important!
 If System Mode is needed for any other purposes, please contact your authorized service representative before performing any operation in System Mode.

Appendix 5 describes usage and purposes of the keys on the Operation Panel in System Mode.

For end users, System Mode should be used for the following five purposes:

- To perform the test print for checking print quality.
- To control more than two printers by one command file.
- To view the current parameter settings.
- To change the character code table.
- To change the control code.

A5.1 Operation Panel

The figure below illustrates the Operation Panel and key functions.

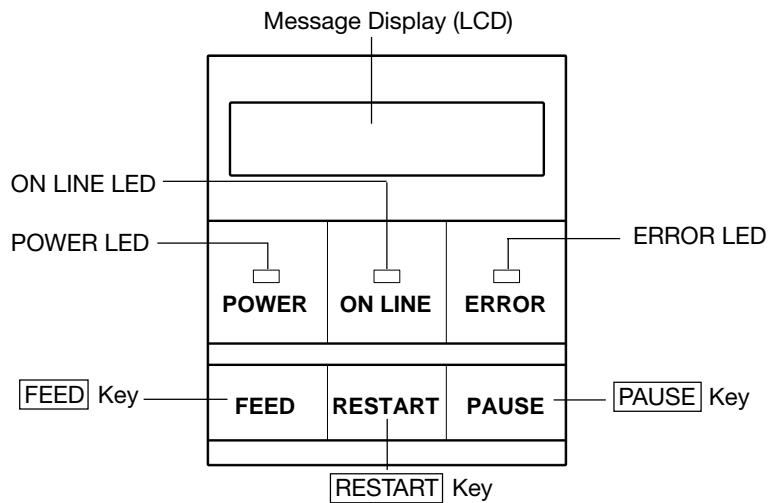

The Message Display shows messages in alphanumeric characters and symbols to indicate the printer's status. Up to 16 characters can be displayed on one line.

There are three LED's on the Operation Panel.

LED	Illuminates when...	Flashes when...
POWER	The printer is turned on.	
ON LINE	The printer is ready to print.	The printer is communicating with your computer.
ERROR	Any error occurs with the printer.	The ribbon supply is low or in a near end condition.

There are three keys on the Operation Panel.

Note:
 Use the **RESTART** key to resume printing after a pause condition, or after clearing an error.

PAUSE	<ul style="list-style-type: none"> • To start the menus in System Mode. • To print out the test results or samples. • To enable the value or option that you enter.
RESTART	<ul style="list-style-type: none"> • To scroll up/down the menus in System Mode. • To select a desired value or option in System Mode.
FEED	

A5.2 Overview

System Mode consists of four main menus: Self-Diagnostic Test, Parameter Setting, Test Print, and RAM clear.

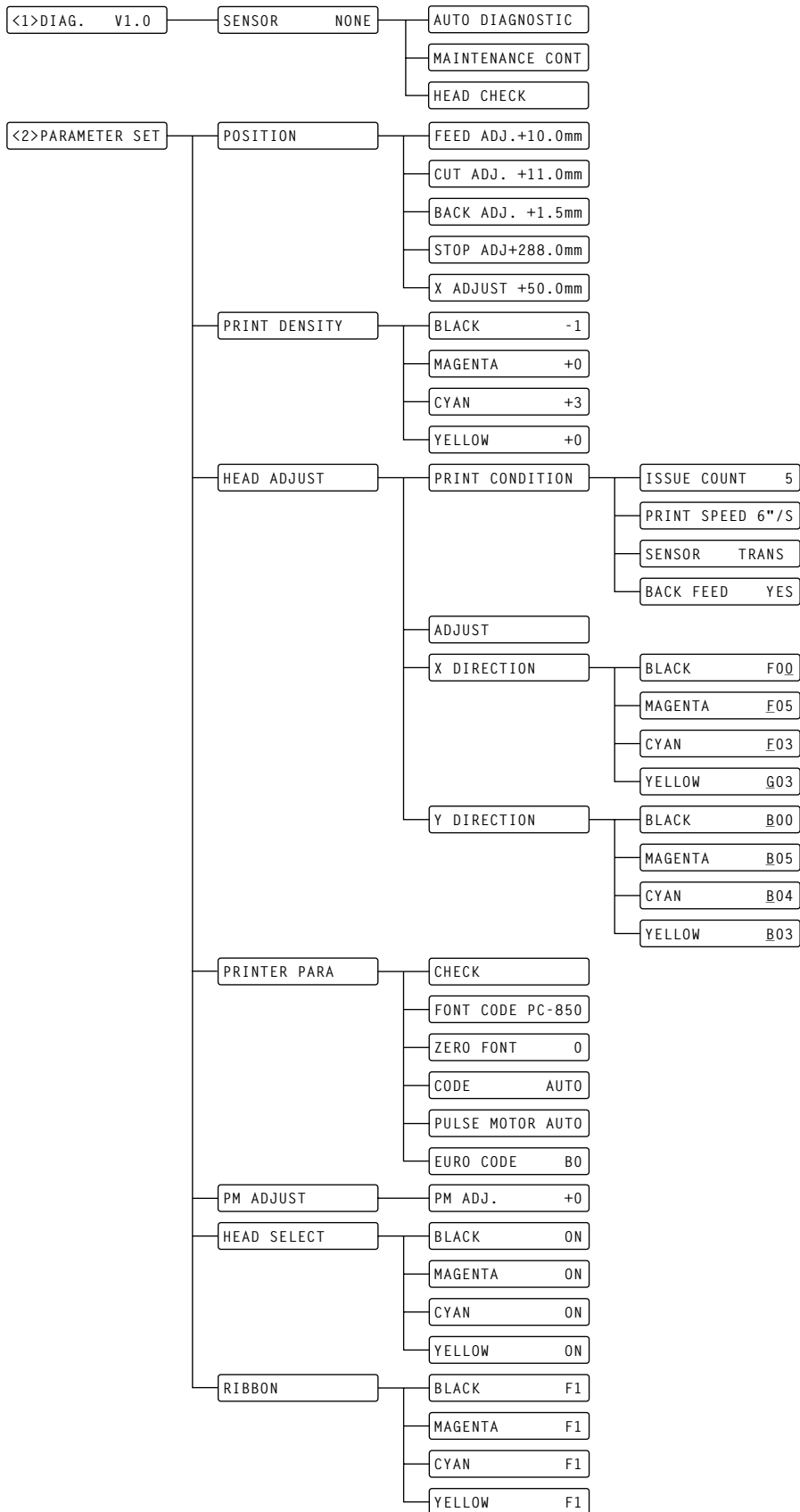

A5.2 Overview (Cont.)

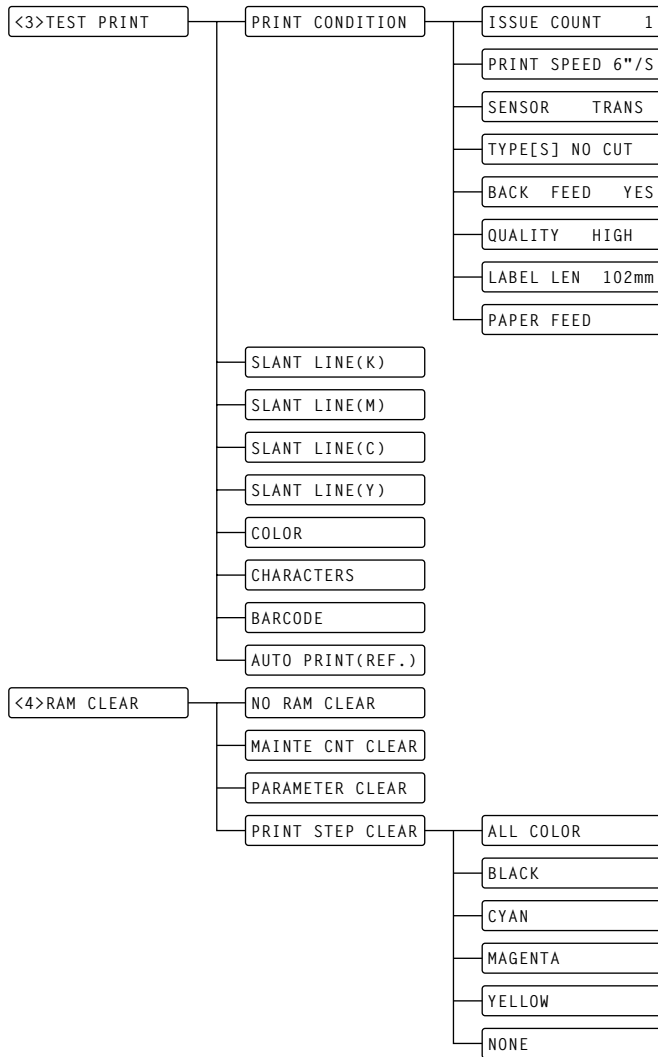

The main menus can be navigated as follows:

Note:
 Press the **RESTART** key.
 This moves back to the previous menu.

<1>DIAG. V1.0

While pressing the **FEED** and **PAUSE** keys at the same time, turn on the printer. Hold both keys until the “<1> DIAG.” message appears in the display.

This is the start of the Self-Diagnostic Test menu.

<2>PARAMETER SET

Press the **FEED** key. This is the start of the Parameter Setting menu.

<3>TEST PRINT

Press the **FEED** key. This is the start of the Test Print menu.

<4>RAM CLEAR

Press the **FEED** key. This is the start of the RAM Clear menu.

A5.3 Self-Diagnostic Test

The Self-**Diagnostic Test** contains the following:

- Selection of the media sensor to be used.
- Performs a Self-Diagnostic Test, and prints out the result.
- Prints out the Maintenance Counter/Parameter Settings.
- Checks to see if there is any problem with the print head.

<1>DIAG. V1.0

While pressing the **FEED** and **PAUSE** keys at the same time, turn on the printer. Hold both keys until the “<1> DIAG.” message appears in the display.

Selecting the Media Sensor to be Used

SENSOR NONE

Press the **PAUSE** key. The type of media sensor can be selected: “NONE” (media position not detected), “REFLECT.” (Reflective Sensor), or “TRANS.” (Transmissive Sensor).

After selecting the media sensor to be used, press the **PAUSE** key.

Note:
Use the **FEED** or **RESTART** key to select a desired option.

Performing the Self-Diagnostic Test, and Printing out the Result

AUTO DIAGNOSTIC

The Self-Diagnostic Test is ready. Press the **PAUSE** key to start.

CHECKING & PRINT

The printer starts the Self-Diagnostic Test, and prints out the result.

- Notes:*
- If any error occurs, an error message appears, and the printer stops printing. After clearing the error, press the **PAUSE** key to return to “<1> DIAG.”. The printer does not restart printing automatically.
 - See Section A5.7.1 for the Self-Diagnostic Test print sample and descriptions.

Print out the Maintenance Counter/Parameter Settings

When the Self-Diagnostic Test result is printed, the message returns to “<1> DIAG.”. Press the **PAUSE** key twice.

MAINTENANCE CONT

The printer is ready to print out the Maintenance Counter/Parameter Settings. Press the **PAUSE** key to start.

CHECKING & PRINT

The printer starts printing out the Maintenance Counter/Parameter Settings.

Note:
See Section A5.7.2 for the Maintenance Counter/Parameter Settings print sample and descriptions.

A5.3 Self-Diagnostic Test (Cont.)

Note:
Make sure that the Top Cover is closed before starting the print head check.

Checking If There is any Problem with the Print Head

When the Maintenance Counter/Parameter Settings is printed, the message returns to “<1> DIAG.”. Press the **PAUSE** key three times.

<1>DIAG. V1.0

The printer is ready to check the print heads to see if there are problems with the print head. Press the **PAUSE** key to start.

HEAD CHECK

The printer starts checking the print heads. It takes about 25 seconds to complete the print head check.

CHECKING

If there is no problem with the print head, the print head check is complete.

Press the **PAUSE** key to return to “<1> DIAG.”.

NORMAL END

If there is a problem with the print head, the message indicates which print head has the problem.

HEAD ERROR KMC

This example indicates that there are problems with the print heads for black, magenta and cyan.

A5.4 Parameter Setting

Notes:

- When pressing the **FEED** and **RESTART** keys at the same time in the parameter setting, the message returns to “<2> PARAMETER SET”.
- If holding the **FEED** or **RESTART** key for 0.5 seconds or longer in the parameter setting, the key is entered continuously.
- A changed parameter becomes enabled by pressing the **PAUSE** key and is stored in memory until the printer is turned off.

Note:
Use the **FEED** or **RESTART** key to select a desired value or option.

The **Parameter Setting** menu contains the following:

- Adjustments for a print start position.
- Adjustments for a cut position.
- Adjustments for a distance of back feed.
- Adjustments for a print stop position.
- Adjustments for an X-coordinate.
- Adjustments for a print density (Y, M, C and K).
- Modifies the alignment in X direction (Y, M, C and K).
- Modifies the alignment in Y direction (Y, M, C and K).
- Initiates printouts of X/Y direction fine adjustment (Caliper-shaped pattern).
- Selection of the character code, “0” font and Control code.
- Adjustments for a pulse motor speed.
- Selection of the print head to be used (Y, M, C and K).
- Selection of the ribbon type (Y, M, C and K).
- Selection of the Euro code.

<1>DIAG. V1.0

While pressing the **FEED** and **PAUSE** keys at the same time, turn on the printer. Hold both keys until the “<1> DIAG.” message appears. Press the **FEED** key.

<2>PARAMETER SET

The printer is at the start of the Parameter Setting menu.

A5.4 Parameter Setting (Cont.)

Making Positional Adjustments

POSITION

When “<2> PARAMETER SET” appears, press the **PAUSE** key.

Print Start Position (-30.0mm to +30.0mm)

FEED ADJ. +10.0mm

Press the **PAUSE** key. Adjust the print start position. After selecting the value, press the **PAUSE** key.

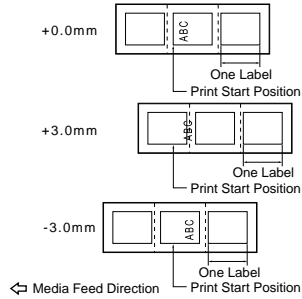

Cut Position (-20.0mm to +20.0mm)

CUT ADJ. +11.0mm

Adjust the cut position. After selecting the value, press the **PAUSE** key.

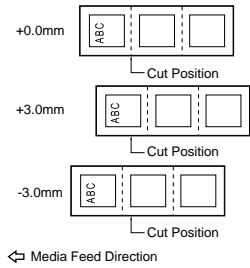

Note:
See A5.7.3 for an example of the cutting operation.

Back Feed Distance (-9.5mm to +9.5mm)

BACK ADJ. +1.5mm

Adjust the distance of back feed. After selecting the value, press the **PAUSE** key.

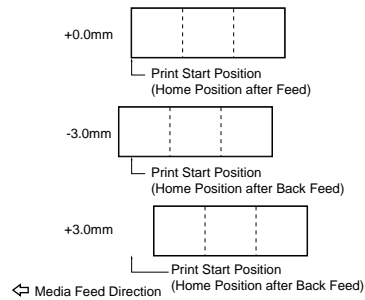

Print Stop Position (-30.0mm to +300.00mm)

STOP ADJ+288.0mm

Adjust the print stop position. After selecting the value, press the **PAUSE** key.

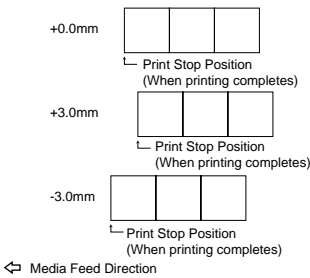

A5.4 Parameter Setting (Cont.)

X-Coordinate (-99.5mm to +99.5mm)

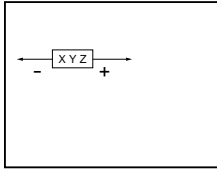

Note:
See A5.7.5 for more detail.

- Notes:*
- Use the **FEED** key for lighter density, or the **RESTART** key for darker density.
 - The acceptable print density values are -50 to +50.
 - The print density value is +0 at shipment from the factory.

X ADJUST +50.0mm

Adjust the X-coordinate.

After entering the value, press the **PAUSE** key. The message returns to “<2> PARAMETER SET”.

Adjusting Print Density (K, M, C and Y)

POSITION

Press the **PAUSE** key. “POSITION” appears. Press the **FEED** key.

PRINT DENSITY

Print density adjustments are ready to be set. Press the **PAUSE** key.

BLACK -1

Adjust the print density of black.

After selecting the value, press the **PAUSE** key.

MAGENTA +0

Adjust the print density of magenta.

After selecting the value, press the **PAUSE** key.

CYAN +3

Adjust the print density of cyan.

After selecting the value, press the **PAUSE** key.

YELLOW +0

Adjust the print density of yellow.

After selecting the value, press the **PAUSE** key.

When the values for all colors are entered, press the **PAUSE** key.

The message returns to “<2> PARAMETER SET”.

A5.4 Parameter Setting (Cont.)

Note:
Use the **FEED** or **RESTART** key to select a desired value or option.

Specifying the Print Condition for the Print Head Adjustment

The print condition for the X/Y Direction Alignment Test should be specified before printing.

PRINT DENSITY

Press the **PAUSE** key. "PRINT DENSITY" appears. Press the **FEED** key again.

HEAD ADJUST

Press the **PAUSE** key.

PRINT CONDITION

Print conditions are ready to be set. Press the **PAUSE** key.

ISSUE COUNT 5

The number of copies for the X/Y Direction Alignment Test can be selected, with a maximum of ten.

After selecting the value, press the **PAUSE** key.

PRINT SPEED 6"/S

Select the print speed options for printing out the X/Y Direction Alignment Test: 6 inches/second or 4 inches/second.

After selecting the speed, press the **PAUSE** key.

SENSOR TRANS

Select the media sensor to be used for printing out the X/Y Direction Alignment Test: "TRANS" (Transmissive Sensor), "REFLECT." (Reflective Sensor) or NONE.

After selecting the media sensor, press the **PAUSE** key.

BACK FEED YES

Specify whether a back feed will be performed when printing the X/Y Direction Alignment Test. Select "YES" for back feeding.

After selecting the back feed option, press the **PAUSE** key.

The message returns to "<2> PARAMETER SET".

A5.4 Parameter Setting (Cont.)

Printing the X/Y Direction Alignment (Caliper-shaped Pattern)

HEAD ADJUST

Press the **PAUSE** key. "HEAD ADJUST" appears. Then press the **PAUSE** key again.

ADJUST

Press the **PAUSE** key. The printer starts printing the X/Y Direction Alignment Tests using the print conditions specified above.

When printing completes, the message returns to "<2> PARAMETER SET".

Based on the printed patterns, make the X/Y direction alignment for all colors.

X/Y Direction Alignment Tests

X Direction

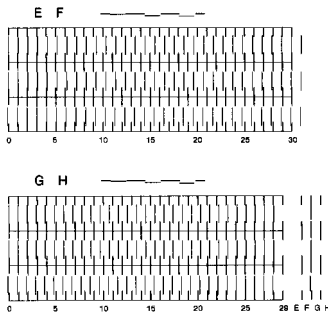

Y Direction

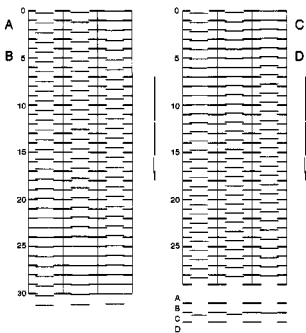

A5.4 Parameter Setting (Cont.)

Notes:

- Use the **FEED** or **RESTART** key to select a desired value or option.
- Use black as the reference color. However, black can be aligned in the same manner as the other three colors.

Note:

When G or H is selected, the acceptable values are 01 to 29.

Adjusting the Alignment in the X Direction (K, M, C and Y)

HEAD ADJUST

Press the **PAUSE** key. “HEAD ADJUST” appears. Then press the **PAUSE** key again.

X DIRECTION

The X direction alignment is ready for adjustment. Press the **PAUSE** key.

BLACK F00

Press the **PAUSE** key twice.

MAGENTA F00

Align magenta in the X direction. Select one of the following letters for the best alignment: E, F, G or H.

When selecting the letter, press the **PAUSE** key.

MAGENTA F00

Next enter the value within a range of 00 to 31 for the best alignment.

After selecting the value, press the **PAUSE** key.

CYAN F05

Then make alignments for the other two colors in the same manner in order of cyan and yellow.

When the alignments are complete, the message returns to “<2> PARAMETER SET”.

Adjusting the Alignment in the Y Direction (K, M, C and Y)

HEAD ADJUST

Press the **PAUSE** key. “HEAD ADJUST” appears. Then press the **PAUSE** key again.

Y DIRECTION

The Y direction alignment is ready for adjustment. Press the **PAUSE** key.

BLACK B00

Press the **PAUSE** key twice

BLACK B05

To align magenta in the Y direction. Select one of the following letters for the best alignment: A, B, C or D.

After selecting the letter, press the **PAUSE** key.

A5.4 Parameter Setting (Cont.)

Note:
When C or D is selected, the acceptable values are 01 to 29.

MAGENTA B00

Next enter the value within a range of 00 to 31 for the best alignment.

When entering the value, press the **PAUSE** key.

CYAN B05

Then make alignments for the other two colors in the same manner in the order of cyan and yellow.

When the alignments are complete, the message returns to “<2> PARAMETER SET”.

Now verify that the X/Y direction alignment is correct.

HEAD ADJUST

Press the **PAUSE** key twice.

CHECK

Press the **PAUSE** key. The printer prints the X/Y Direction Alignment Test.

After printing completes, the message returns to “<2> PARAMETER SET”.

Selecting the Printer Parameters

HEAD ADJUST

Press the **PAUSE** key.

After “HEAD ADJUST” appears, press the **FEED** key.

PRINTER PARA

The printer parameters are ready to be selected. Press the **PAUSE** key.

Specifying the Character Code

FONT CODE PC-850

Select the character codes: PC-850 or PC-8.

After selecting the code, press the **PAUSE** key.

Specifying Zero Font

ZERO FONT 0

Select whether a 0 (zero) with a slash or no slash will be used.

After selecting the zero font, press the **PAUSE** key.

Note:
Use the **FEED** or **RESTART** key to select a desired value or option.

A5.4 Parameter Setting (Cont.)

Note:
See A5.7.4 for further information about the pulse motor speed.

Specifying the Control Code Selection Method

CODE AUTO

Select the Control Code methods: “AUTO” (automatic selection), or “ESC, LF, NUL” or “{, |, }” or (manual selections). After selecting the method, press the **PAUSE** key.

PULSE MOTOR AUTO

Select one of the following pulse motor speeds: AUTO or 104. If selecting “AUTO”, the pulse motor cycle varies depending on the operating temperature. If “104” is selected, the pulse motor cycle is fixed at 104%.

After selecting the pulse motor speed, press the **PAUSE** key.

Specifying the Euro Code

EURO CODE B0

Select one of the following Euro codes: FFH, FEH to B0H, B0H to 21H or 20H.

After selecting the Euro code, press the **PAUSE** key. The message returns to “PRINTER PARA”.

Adjusting the Pulse Motor Speed

PRINTER PARA

After “PRINTER PARA” appears, press the **FEED** key.

PM ADJUST

To make a fine adjustment of the pulse motor speed, press the **PAUSE** key.

PM ADJ. +0

Note:
Use the **FEED** or **RESTART** key to select a desired value.

The acceptable values are -60 to +60. As the value becomes lower, the motor speed becomes faster.

After adjusting the pulse motor speed, press the **PAUSE** key. The message returns to “<2> PARAMETER SET”.

A5.4 Parameter Setting (Cont.)

Note:
Use the **FEED** or **RESTART** key to enter a desired option.

Note:
The ribbon type can also be changed in the printer properties on the computer. See Section 3.8.1.

Specifying the Print Head to be Used

PM ADJUST

Press the **PAUSE** key.

After “PM ADJUST” appears, press the **FEED** key.

HEAD SELECT

To select which print heads will be used, press the **PAUSE** key.

BLACK ON

Select “ON” to use the black print head. Otherwise “OFF” will disable the head.

After making a selection, press the **PAUSE** key.

MAGENTA ON

Make a selection for the other three colors in the same manner.

After making the selections, press the **PAUSE** key, and the message returns to “<2> PARAMETER SET”.

Specifying the Ribbon Type to be Used

HEAD SELECT

Press the **PAUSE** key.

After “HEAD SELECT” appears, press the **FEED** key.

RIBBON

The ribbon type for each color can be selected. Press the **PAUSE** key.

BLACK F1

Select which ribbon will be used for the black ribbon: F1 (Hot Release Ribbons) or P1S (Cold Release Ribbons).

After selecting the ribbon type, press the **PAUSE** key.

MAGENTA F1

Select the ribbon type for the other color ribbons in the same manner.

After selecting the ribbon type for all colors, press the **PAUSE** key. The message returns to “<2> PARAMETER SET”.

A5.5 Test Print

Notes:

- When pressing the **FEED** and **RESTART** keys at the same time in the Test Print menu, the message returns to “<3> TEST PRINT”.
- If holding the **FEED** or **RESTART** key for 0.5 seconds or longer in the Test Print menu, the key is entered continuously.
- The fine adjustment parameters are effective for the test print.
- If any error occurs, an error message appears, and the printer stops printing. After clearing the error, press the **PAUSE** key to return to the System Mode menu. The printer does not restart printing automatically.
- A changed parameter becomes enabled by pressing the **PAUSE** key and is stored in memory until the printer is turned off.

Note:
Use the **FEED** or **RESTART** key to select a desired value or option.

Note:
When the Transmissive Sensor is selected, the gap between labels should be 2 mm.

The **Test Print** menu contains the following:

- Prints the parameter settings and slant line.
- Prints the color band patterns.
- Prints the characters and bar codes.
- Performs the automatic print out for the assembly process. (Transmissive/Reflective Sensor)

<1>DIAG. V1.0

While pressing the **FEED** and **PAUSE** keys at the same time, turn on the printer. Hold both keys until the “<1> DIAG.” message appears. Then press the **FEED** key twice.

<3>TEST PRINT

The Test Print is ready to be performed. Press the **PAUSE** key.

Specifying the Print Condition for the Test Print

The print condition for the Test Print should be specified before printing.

PRINT CONDITION

Press the **PAUSE** key. “ISSUE COUNT” appears. Press the **PAUSE** key again.

ISSUE COUNT 1

The number of copies can be selected, with a maximum of 5000. After entering the value, press the **PAUSE** key.

PRINT SPEED 6"/S

Select the print speed options for the test print: 6 inches/second or 4 inches/second.

After selecting the print speed, press the **PAUSE** key.

SENSOR TRANS

Select the media sensor to be used for the test print: “TRANS” (Transmissive Sensor), “REFLECT.” (Reflective Sensor) or NONE.

After selecting the media sensor, press the **PAUSE** key.

A5.5 Test Print (Cont.)

TYPE[S] NO CUT

Select the issue mode for the print test: “[S] NO CUT” (Batch mode without cutting) or “[C] WITH CUT” (Cut Mode). After selecting the issue mode, press the **PAUSE** key.

BACK FEED YES

Specify whether a back feed will be performed when printing the test print. Select “YES” for back feeding. After selecting the back feed option, press the **PAUSE** key.

QUALITY HIGH

Select the print quality for the test print: “HIGH” (ribbon saving disabled) or “NORMAL” (ribbon saving enabled). If “HIGH” is chosen, print quality is higher. After selecting the print quality, press the **PAUSE** key.

Note:
The label length (pitch) will be 1300mm if a SIMM is added to the printer

LABEL LEN 102mm

Select a label size for the test print. The acceptable values are 10mm to 1050mm. After selecting the label size, press the **PAUSE** key.

PAPER FEED

To feed the media before the test print, press the **PAUSE** key. If media feed is not necessary, select “PAPER NO FEED” using either **FEED** or **RESTART** key. The message returns to “<3> TEST PRINT”.

Printing out the Slant Line Pattern

<3>TEST PRINT

After “<3> TEST PRINT” is shown, press the **PAUSE** key.

PRINT CONDITION

Press the **FEED** key again.

SLANT LINE(K)

Press the **PAUSE** key to start printing the slant line pattern for black. After the printing completes, the message returns to “<3> TEST PRINT”. Press the **PAUSE** key. “SLANT LINE K” appears again. Press the **FEED** key.

Test Print: Slant Line Pattern

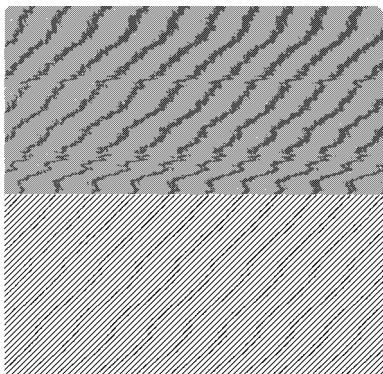

Note:
See A5.7.6 for further information.

A5.5 Test Print (Cont.)

Note:
Press the **FEED** key to skip the slant line pattern print for any color not required.

Test Print: Color Band Pattern

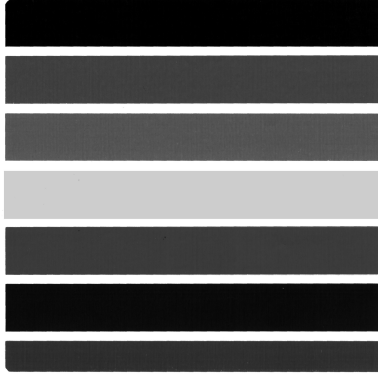

Test Print: Character Pattern

A/0123456789@ABCDEFGHIJKLM G/0123456789@ABCDEFGHIJKLMNPQRS
 B/0123456789@ABCDEFGHI H/0123456789@ABCDEFGHI
 C/0123456789@ABCDEFGHI I /0123456789@ABCDE
 D/0123456789@ABCDEFGHI J /0123456789@ABCDE
 E/0123456789@ABCD K/0123456789@ABC
 F/0123456789@ABCDEF L/0123456789@ABCDE
 M/0123456789@ABCDEFGHIJKLM
 N/0123456789ABCDEFGHIJKLMNPQRS
 O/0123456789ABCDEFGHIJKLMNPQRS
 P/0123456789ABCDEFGHIJ
 Q/0123456789ABCDEFGHIJ
 R/0123456789ABCDEF
 S/0123456789ABCDEFGHI
 T/0123456789ABCDEFGHI

A B

Test Print: Bar Code Pattern

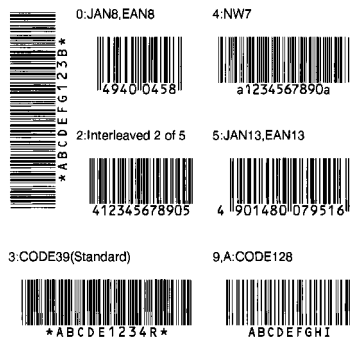

SLANT LINE(M)

The slant line pattern is ready to be printed. The slant line patterns for the other colors can be printed in the same manner.

Printing out the Color Band Pattern

COLOR

Press the **PAUSE** key to begin printing the color band pattern. After printing completes, the message returns to “<3> TEST PRINT”. Press the **PAUSE** key. “COLOR” appears again. Press the **FEED** key.

Printing out the Characters

CHARACTERS

Press the **PAUSE** key to print the character pattern. After printing completes, the message returns to “<3> TEST PRINT”. Press the **PAUSE** key. “CHARACTERS” appears again. Press the **FEED** key.

Printing out the Bar Codes

BARCODE

Press the **PAUSE** key to print the bar code pattern. After printing completes, the message returns to “<3> TEST PRINT”. Press the **PAUSE** key. “BARCODE” appears again. Press the **FEED** key.

Performing the Automatic Printout for the Assembly Process

AUTO PRINT(REF.)

Press the **PAUSE** key. The printer starts the test prints in the order of the slant line (all colors), color band, characters and bar codes patterns. The **PAUSE** key must be pressed after each test print pattern is printed out. Press the **FEED** and **RESTART** keys at the same time to exit the automatic printout mode at any time.

A5.6 RAM Clear

Notes:

- When pressing the **FEED** and **RESTART** keys at the same time in RAM Clear or “NO RAM CLEAR”, the message returns to “<4> RAM CLEAR”.
- After RAM clear, the following items are still stored: X/Y direction fine adjustment value, total label distance covered, sensor adjustment value and data in the flash memory.

The **RAM Clear** menu contains the following:

- Maintenance Counter clear.
- Parameter clear.
- Print Step clear.

<1>DIAG. V1.0

While pressing the **FEED** and **PAUSE** keys at the same time, turn on the printer. Hold both keys until the “<1> DIAG.” message appears. Then press the **FEED** key three times.

<4>RAM CLEAR

RAM clear functions are ready to be performed. Press the **PAUSE** key.

NO RAM CLEAR

Press the **PAUSE** key not to perform a RAM clear.

The message returns to “<4> RAM CLEAR”.

Press the **PAUSE** key. “NO RAM CLEAR” appears again. Press the **FEED** key.

Clearing the Maintenance Counter

Note:

See A5.7.7 for further information about the initial values after clearing the Maintenance Counter.

MAINTE CNT CLEAR

The Maintenance Counter can be cleared by pressing the **PAUSE** key.

COMPLETE

The Maintenance Counter is cleared.

The printer must be turned off to exit this mode.

Clearing the Parameter

Note:

See A5.7.8 for further information about the initial values after clearing the parameters.

NO RAM CLEAR

When “<4> RAM CLEAR” is shown, press the **PAUSE** key. “NO RAM CLEAR” appears again. Press the **FEED** key twice.

PARAMETER CLEAR

The parameters can be cleared by pressing the **PAUSE** key.

COMPLETE

The parameters are cleared.

The printer must be turned off to exit this mode.

A5.6 RAM Clear (Cont.)

Notes:

- See A5.7.9 for further information about the initial values after clearing the print distance.
- To clear the print distance for a particular color, press the **FEED** key to select the color. Select “NONE” not to clear the print distance for any of colors.

Clearing the Print Distance

NO RAM CLEAR

When “<4> RAM CLEAR” is shown, press the **PAUSE** key. “NO RAM CLEAR” appears again. Press the **FEED** key three times.

PRINT STEP CLEAR

The print distance can be cleared by pressing the **PAUSE** key.

ALL COLOR

The print distance for all colors can be cleared by pressing the **PAUSE** key.

When the print distance for all colors is cleared successfully, “COMPLETE” appears.

The printer must be turned off to exit this mode.

A5.7.2 Maintenance Counter/Parameter Check Print Sample and Descriptions

TL FEED	:	2.8Km			
FEED	:	1.5Km			
CUT	:	35			
232C ERR	:	0			
PW FALL	:	0			
		BLACK	MAGENTA	CYAN	YELLOW
PRINT	:	1.2Km	1.2Km	1.2Km	1.1Km
HEAD U/D	:	192	65	98	61
RIBBON	:	0h	0h	0h	0h
		[PC]		[KEY]	
FEED	:	+0.0mm		-2.0mm	
CUT	:	+0.0mm		+0.0mm	
BACK	:	+0.0mm		+0.0mm	
STOP	:	+0.0mm		+0.0mm	
X ADJ.	:	---		+0.0mm	
		[PC]			
		BLACK	MAGENTA	CYAN	YELLOW
X DIRECTION	:	+0.00mm	+0.00mm	+0.00mm	+0.00mm
Y DIRECTION	:	+0.00mm	+0.00mm	+0.00mm	+0.00mm
TONE	:	+0step	+0step	+0step	+0step
RIBBON VOLTAGE	:				
REWIND	:	+0step	+0step	+0step	+0step
SUPPLY	:	+0step	+0step	+0step	+0step
		[KEY]			
		BLACK	MAGENTA	CYAN	YELLOW
X DIRECTION	:	+0.00mm	+0.00mm	+0.00mm	+0.00mm
Y DIRECTION	:	+0.00mm	+0.00mm	+0.00mm	+0.00mm
TONE	:	+0step	+0step	+0step	+0step
FONT	:	[PC-850]	[0]		
CODE	:	[AUTO]			

① Maintenance Counter

- Total label distance covered (cannot be cleared)
- Label distance covered
- Print distance (Y, M, C, K)
- Cut count
- Head-up/down count (Y, M, C, K)
- Ribbon motor drive time (Y, M, C, K)
- RS-232C hardware error count
- Momentary power interruption count

② Parameters

- Print start position fine adjustment value
- Cut position fine adjustment value
- Back feed fine adjustment value
- Stop position fine adjustment value
- X direction fine adjustment value (for adjustment before shipment from the factory) (Y, M, C, K)
- Y direction fine adjustment value (for adjustment before shipment from the factory) (Y, M, C, K)
- Print density fine adjustment value (Thermal transfer) (Y, M, C, K)
- X-coordinate fine adjustment value
- Character code type
- Font "0"
- Control code type

A5.7.3 Cut Operation Example

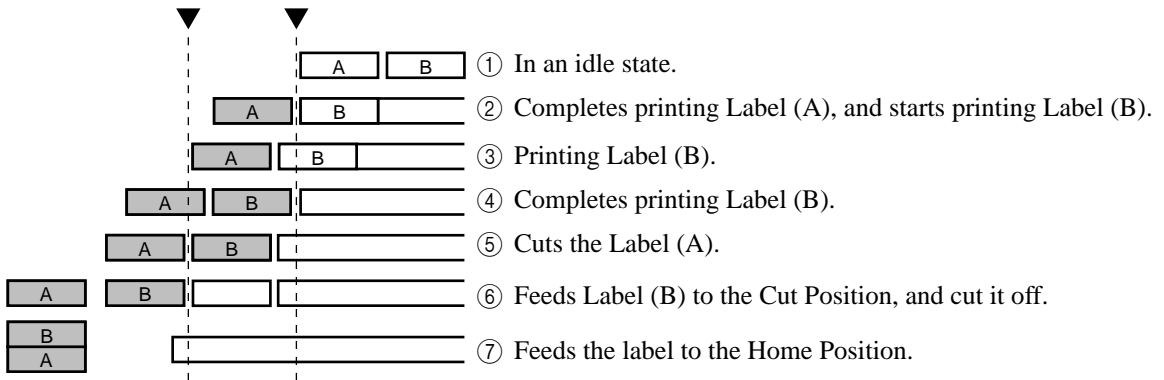

A5.7.4 Pulse Motor Speed

- Usually “AUTO” should be selected. Depending on print patterns, the colors may not be aligned, and the pulse motor speed fine adjustment should be made.
- The pulse motor speed adjustment allows more precise color registration. However, if the pulse motor speed needs changing, please contact an authorized service representative.

A5.7.5 X-Coordinate Fine Adjustment

The X-coordinate fine adjustment is made to adjust the X-coordinate of the drawing horizontally. The X-coordinate fine adjustment should be made in the effective print range. (If a field reaches the coordinate less than “0” after the fine adjustment is made in the negative direction, it is adjusted in the negative direction.)

A5.7.6 Magnified Views of Slant Line Pattern

- 1-Dot Slant Line (Black Area Ratio: 16.7%)

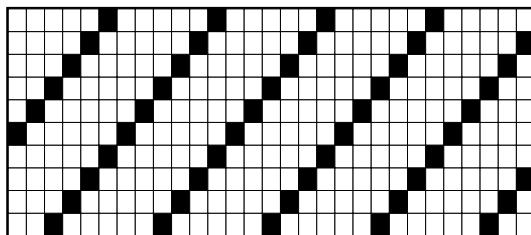

- 3-Dot Slant Line (Black Area Ratio: 16.7%)

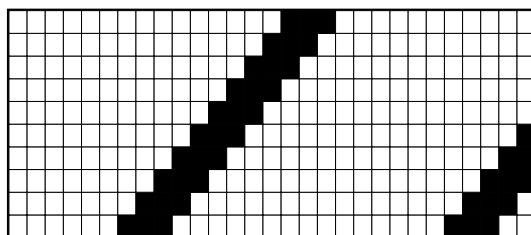

A5.7.7 Initial Values after Clearing the Maintenance Counter (MAINTE.CNT.CLEAR)

Item	Initial Value
Label distance covered	0 km
Print distance (Black)	0 km
Print distance (Magenta)	0 km
Print distance (Cyan)	0 km
Print distance (Yellow)	0 km
Cut count	0
Head up/down count (Black)	0
Head up/down count (Magenta)	0
Head up/down count (Cyan)	0
Head up/down count (Yellow)	0
Ribbon motor drive time (Black)	0 hour
Ribbon motor drive time (Magenta)	0 hour
Ribbon motor drive time (Cyan)	0 hour
Ribbon motor drive time (Yellow)	0 hour
RS-232C hardware error count	0
Momentary power interruption count	0

A5.7.8 Initial Values after Clearing the Parameter (PARAMETER CLEAR)

Item	Initial Value
Print start position fine adjustment	0.0 mm
Cut position fine adjustment	0.0 mm
Back feed fine adjustment	0.0 mm
Stop position fine adjustment	0.0 mm
X direction fine adjustment (Black)	0.00 mm
X direction fine adjustment (Magenta)	0.00 mm
X direction fine adjustment (Cyan)	0.00 mm
X direction fine adjustment (Yellow)	0.00 mm
Y direction fine adjustment (Black)	0.00 mm
Y direction fine adjustment (Magenta)	0.00 mm
Y direction fine adjustment (Cyan)	0.00 mm
Y direction fine adjustment (Yellow)	0.00 mm
Print density fine adjustment (Black)	0 step
Print density fine adjustment (Magenta)	0 step
Print density fine adjustment (Cyan)	0 step
Print density fine adjustment (Yellow)	0 step
Ribbon rewind motor drive voltage fine adjustment (Black)	0 step
Ribbon rewind motor drive voltage fine adjustment (Magenta)	0 step
Ribbon rewind motor drive voltage fine adjustment (Cyan)	0 step
Ribbon rewind motor drive voltage fine adjustment (Yellow)	0 step
Ribbon back tension motor drive voltage fine adjustment (Black)	0 step
Ribbon back tension motor drive voltage fine adjustment (Magenta)	0 step
Ribbon back tension motor drive voltage fine adjustment (Cyan)	0 step
Ribbon back tension motor drive voltage fine adjustment (Yellow)	0 step
Print start position fine adjustment	0.0 mm
Cut position fine adjustment	0.0 mm
Back feed fine adjustment	0.0 mm
Stop position fine adjustment	0.0 mm
Print density fine adjustment (Black)	0 step
Print density fine adjustment (Magenta)	0 step
Print density fine adjustment (Cyan)	0 step
Print density fine adjustment (Yellow)	0 step
X-coordinate fine adjustment	0.0 mm
Character code selection	PC-850
Font "0" selection	"0" without slash mark
Control code type	AUTO
Label pitch	102.0 mm
Sensor type	Transmissive sensor
Feed/Print speed	6 inches/sec
With/Without cutting	Without cutting
Status response	With
With/Without ribbon saving	Without
Printing top/bottom first	Printing bottom first
With/Without back feed	Without
Ribbon type	F1 (Hot Release Ribbons)
Head use selection	All heads used
Pulse motor speed	AUTO (Fine A/D value: 0)
Euro code	B0H

A5.7.9 Initial Values after Clearing the Print Distance (PRINT STEP CLEAR)

Item	Initial Value
Print distance (Black)	0.0 km
Print distance (Magenta)	0.0 km
Print distance (Cyan)	0.0 km
Print distance (Yellow)	0.0 km

Appendix 6 Interface

This printer has the following requirements:

- The computer must have a serial port or centronics parallel port.
- To communicate with the computer, either an RS-232C cable, Centronics cable or Expansion I/O Cable is required. (For pin description of the RS-232C, refer to the table below.)
 - (1) RS-232C cable 25 pins
 - (2) Centronics cable 36 pins
 - (3) Expansion I/O cable 24 pins
- To set up the initial printer configuration, use either the keyboard on the printer or the DIP switch.
- To print a format, create the complete program using the interface/communication manual.

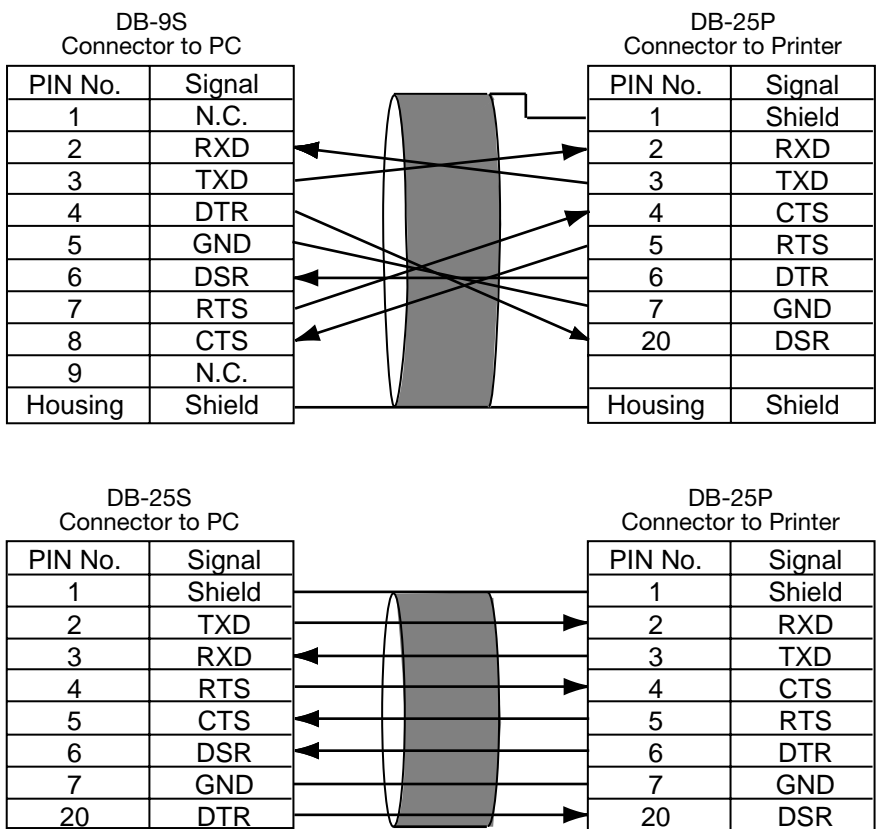

Notes:
Use an RS-232C cable with inch type securing screws on the connector.



TEC
TOSHIBA TEC CORPORATION

E PRINTED IN JAPAN
EO1-33022