

## PDM9

# Housings: Indoor Drop Ceiling Mount

### PRODUCT FEATURES

- The model PDM9 is a discreet indoor surveillance enclosure designed to mount into a standard 2' x 2' or 2' x 4' suspended ceiling, and can be used alone or in conjunction with the entire ceiling tile
- This unit completely encloses the unitized camera, resulting in discreet viewing
- For indoor use
- Designed for the WV-CS954/WV-CS574/WV-NS324 Series cameras

### MECHANICAL SPECIFICATIONS

#### **Size (HxWxD):**

24" x 24" x 10" (610mm x 610mm x 254mm)

Weight: 13 lbs. (5.9 kg) without camera

#### **Construction:**

Metal Ceiling: Frame 18-gauge steel with an off-white powder coat finish

Metal back box: 18- and 20-gauge steel, w/black powder coat finish

Decorative Trim Ring: ABS Plastic, off-white

Electrical Input: (3) .875" knockouts

### STANDARD ACCESSORIES

- 1 pc. PDM9 Instructions
- 4 pc. 8-32 Phillips head screws
- 4 pc. Star washers for mount camera
- 4 pc. 1" long aluminum standoffs

### SHIPPING

PDM9: 16 lbs / 28" x 28" x 8"

(7.3 kg / 712mm x 712mm x 204mm)



*camera not included*

### DESCRIPTION

The **PDM9** is an attractive, drop ceiling mount. The **PDM9** is easy to install. Just remove the existing ceiling tile and place the **PDM9** in its place. The product works with the WV-CS954/WV-CS574/WV-NS324 Series cameras.



**Panasonic ideas for life**

**BID SPECIFICATIONS**

The drop ceiling mount bracket shall be a Panasonic Model PDM9 or equivalent. The bracket shall be designed for a discreet indoor surveillance enclosure, designed to mount into a standard 2' x 2' or 2' x 4' suspended ceiling. The bracket can be used

alone or in conjunction with the entire ceiling tile. The bracket shall be designed for use with Panasonic Unitized Surveillance Device Series WV-CS954/WV-CS574/WV-NS324. The bracket's weight shall not exceed 15 lbs. (6.9 kg).

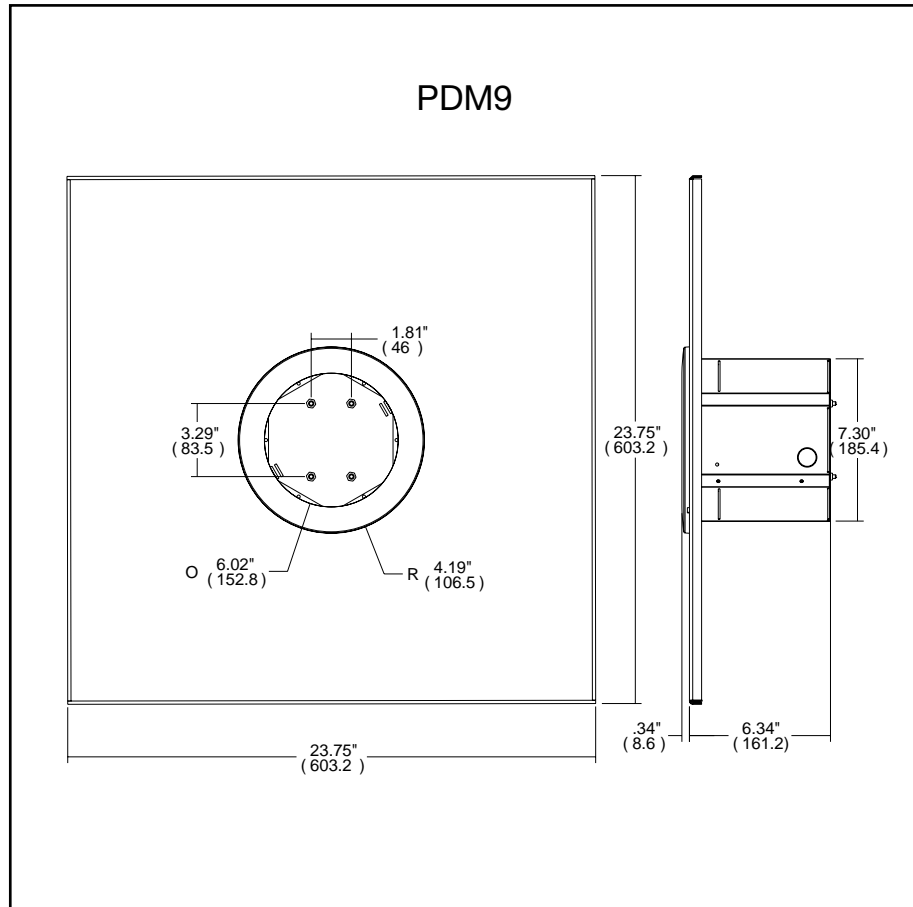

**Panasonic ideas for life**

DISTRIBUTED BY:

**Panasonic System Solutions Company**  
 Unit of Panasonic Corporation of North America  
**Security Systems**

Executive Office: Three Panasonic Way, Secaucus, NJ 07094  
 Zone Offices:

**Eastern:** Three Panasonic Way, Secaucus, NJ 07094 (201) 392-4546

**Southern:** 1225 Northbrook Parkway, Suwanee, GA 30024 (770) 338-6843

**Central:** 1707 North Randall Road, Elgin, IL 60123 (847) 468-5211

**Western:** 6550 Katella Avenue, Cypress, CA 90630 (714) 373-7840

[www.panasonic.com/security](http://www.panasonic.com/security)