

Using the KODAK PROFESSIONAL READYLOAD Single-Sheet Packet

Kodak

TECHNICAL DATA / REFERENCE

August 2007 • E-2549

KODAK PROFESSIONAL READYLOAD Single-Sheet Packets and the KODAK PROFESSIONAL READYLOAD Packet Film Holder provide a very convenient way to expose 4 x 5-inch sheet film. You can use them together as a handy alternative to standard 4 x 5-inch sheet-film holders.

You'll have less equipment to carry, because you can use a single holder to make as many exposures as you need. The sealed packet also keeps light, fingerprints, and dust safely away from the film.

Each READYLOAD Single-Sheet Packet contains one sheet of 4 x 5-inch film, which is attached on both ends to a leader and trailer. The lighttight outer envelope performs the same function as a dark slide in a conventional sheet-film holder.

KODAK PROFESSIONAL READYLOAD Single-Sheet Packets

New READYLOAD Single-Sheet Packets offer these features:

- One preloaded 4 x 5-inch sheet of film per packet
- Great ease and convenience of use—no darkroom or loading bags required; lighter and less bulky than standard 4 x 5-inch film holders
- Less time in the dark—no more film holders to load and unload
- Protection against light leaks, dust, and dirt during use
- Protection against abrasions and fingerprints that can occur while loading sheet-film holders
- Easy unloading for processing with standard processing equipment
- Color-coded packet graphics for easy film identification
- Compatibility with the POLAROID Model 545i Film Holder

Film Availability

The films packaged in KODAK PROFESSIONAL READYLOAD Single-Sheet Packets are listed below. Refer to www.kodak.com/go/readyload for more information on these films.

KODAK Film	CAT No.
PROFESSIONAL PORTRA 160VC Film	834 6926
PROFESSIONAL EKTACHROME E100G	840 3545
PROFESSIONAL EKTACHROME E100VS	825 4328
PROFESSIONAL T-MAX 100 / 100TMX	894 9281

KODAK PROFESSIONAL READYLOAD Packet Film Holder

This 4 x 5-inch film holder fits any standard press or view camera, as well as many scientific and recording instruments. The holder can replace or complement your standard 4 x 5-inch sheet-film holders.

Use this holder to expose film packaged in KODAK PROFESSIONAL READYLOAD Single-Sheet Packets. It offers the following features:

- Accurate alignment and positioning in the film plane
- Light weight and easy to use

INSTRUCTIONS

Using KODAK PROFESSIONAL READYLOAD Single-Sheet Packets in the KODAK PROFESSIONAL READYLOAD Packet Film Holder

To expose the film, follow these steps:

1. Grasp the end of the packet and insert it into the holder until it comes to a firm stop.

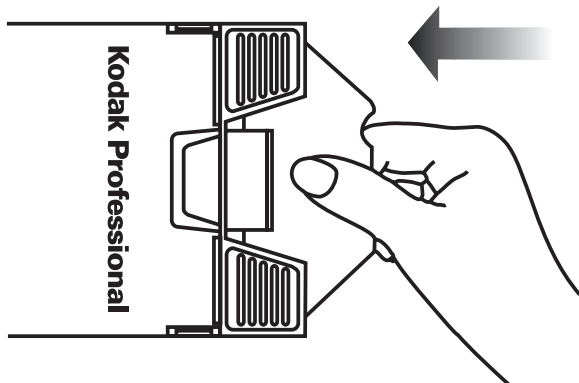

2. When you are ready to expose the film, grasp the end of the outer protective envelope as shown and pull it out until it stops. You should see part of the stop zone. **Do not squeeze the release bar during this step.**

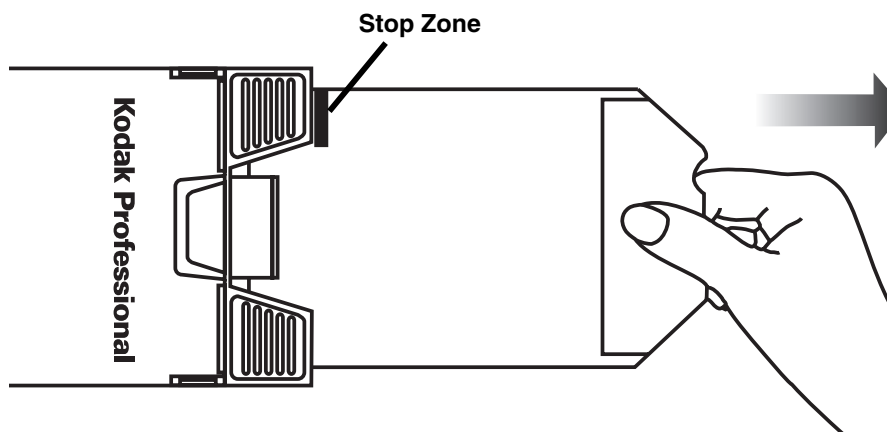

3. Expose the film as you normally do.
4. Push the outer envelope all the way into the holder until it comes to a firm stop. **Do not squeeze the release bar during this step.**

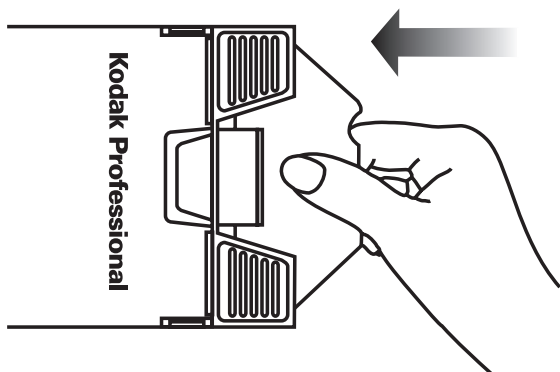

5. To remove the packet from the holder, squeeze and hold the release bar. Then grasp the end of the packet as shown, and pull it straight out. Do not bend the packet when you remove it from the holder.

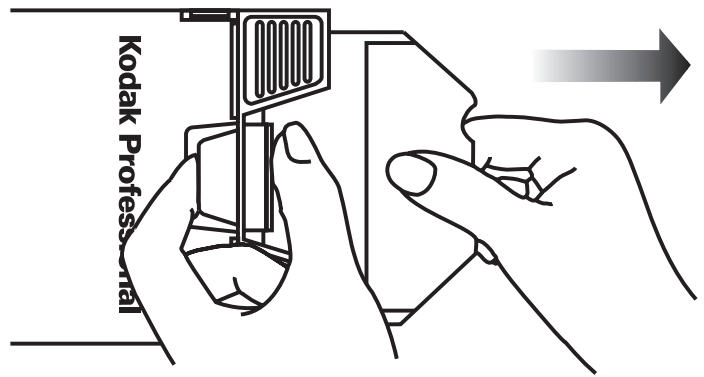

6. Wrap an "Exposed" sticker around the end of the packet with the metal clip.

Operating Tips

- When you insert and remove the packet, grasp the end of the envelope between your thumb and index finger.
- When you squeeze and hold the release bar, keep it fully depressed.
- Use a dark cloth when shooting outdoors in bright sunlight.
- Keep the READYLOAD Packet Film Holder clean. Press down on the pressure plate and use compressed air to remove dust and dirt. You can clean the pressure plate with KODAK PROFESSIONAL Lens Cleaner.
- When you pull the envelope out to expose the film (Step 2), part of the stop zone will be visible. To verify that your packet was inserted correctly, feel the withdrawn packet envelope. You should NOT feel the thickness of the film. If you feel the film, the packet was not seated properly. Push the packet back into the holder until it comes to a firm stop. Then repeat Step 2.
- The release bar should only be used when removing the packet from the holder. If you forget to squeeze and hold the release bar and force the packet from the holder, the clip may detach from the packet and stay in the holder. If this happens, remove the holder from the camera and depress the pressure plate. Shake the holder until the clip falls out.
- The foil bag can be reused to store exposed packets.

Using the KODAK PROFESSIONAL READYLOAD Single-Sheet Packet in the POLAROID 4 x 5 Film Holder, Model 545i

To expose the film, follow these steps:

1. Move the control arm to "L." Grasp the end of the packet and insert the packet into the holder until it comes to a firm stop.

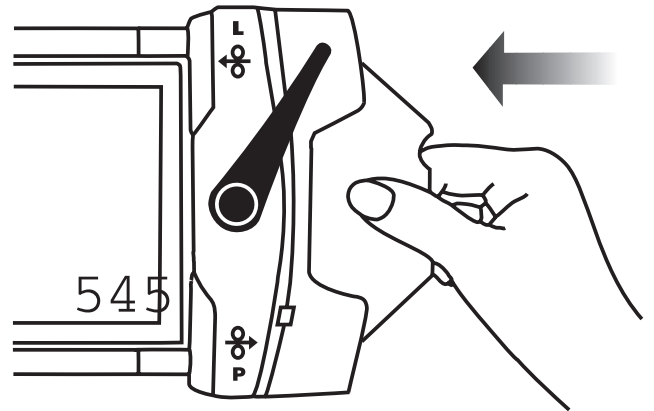

2. Grasp the outer protective envelope as shown, and pull it out until it stops. You should see part of the stop zone.
3. Expose the film as you normally do.
4. Push the outer envelope all the way back into the holder until it comes to a firm stop.
5. To remove the packet from the holder, squeeze and hold the release lever ("R"). **Leave the control arm at "L."** Then pull the packet straight out. Do not bend the packet when you remove it from the holder.

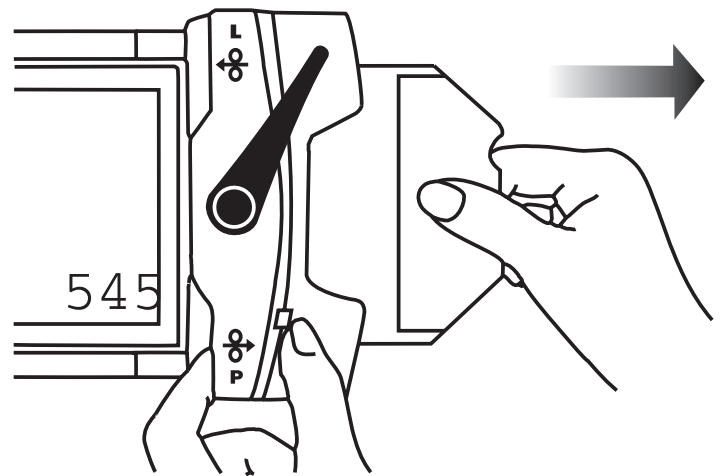

6. Wrap an "Exposed" sticker around the end of the packet with the metal clip.

Using the KODAK PROFESSIONAL READYLOAD Single-Sheet Packet

PROCESSING

To unload the film from the packet for processing, follow these steps:

Handle exposed film in *total darkness*. To avoid getting fingerprints on the film, wear cotton or nylon gloves when you unload it for processing.

1. Remove or tear the "Exposed" sticker.
2. Grasp both ends of the metal clip with one hand. Grasp the other end of the packet with your other hand. Tug gently to unseat the clip from the outer envelope. Pull the film assembly out of the outer envelope.
3. Hold the film assembly so that the base side is up. (The leader and trailer are attached to the base side of the film.) Peel away the trailer and clip.

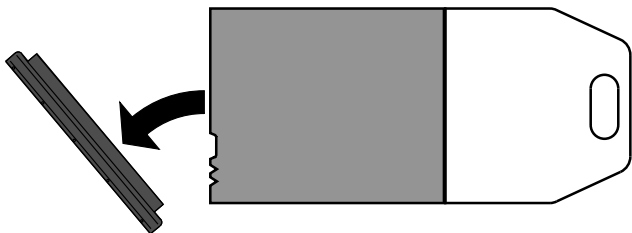

4. Peel the leader away from the film.

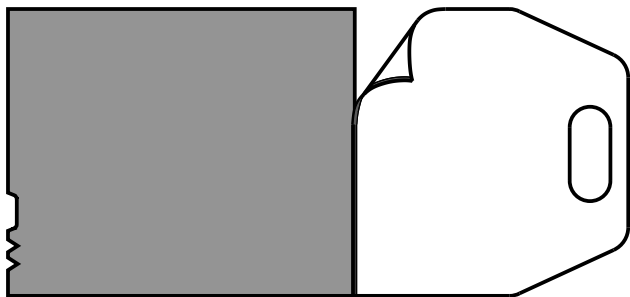

Note: It is generally easier to peel the leader and trailer from the film rather than peel the film from the leader/trailer.

5. Process the film as you normally do.
6. Save the cover envelope if you made notes on it.

MORE INFORMATION

Kodak has many publications to assist you with information on Kodak products, equipment, and materials.

Additional information is available on the Kodak website and through the U.S.A./Canada faxback system.

The following publications are available from Kodak Customer Service, from dealers who sell Kodak products, or you can contact Kodak in your country for more information.

E-190 KODAK PROFESSIONAL PORTRA Films

E-163 KODAK PROFESSIONAL EKTACHROME Film E100VS

F-4016 KODAK PROFESSIONAL T-MAX Films

For the latest version of technical support publications for KODAK PROFESSIONAL Products, visit Kodak on-line at:
<http://www.kodak.com/go/professional>

If you have questions about KODAK PROFESSIONAL Products, call Kodak.

In the U.S.A.:

1-800-242-2424, Ext. 19, Monday-Friday

9 a.m.-7 p.m. (Eastern time)

In Canada:

1-800-465-6325, Monday-Friday

8 a.m.-5 p.m. (Eastern time)

Kodak, Kodak Professional, Ektachrome, Portra, Readyload, and T-Max are trademarks.

Revised 8-07
Printed in U.S.A.

Using the KODAK PROFESSIONAL
READYLOAD Single-Sheet Packet
KODAK Publication No. E-2549

Film & Photofinishing Systems Group
EASTMAN KODAK COMPANY • ROCHESTER, NY 14650

Kodak