

POWER LIFT KIT

MFG. NO. 1690043 POWER LIFT KIT

OPERATOR'S MANUAL

MFG. NO. 1690043 POWER LIFT KIT

To install the electric lift kit follow the numbered steps below.

1. Remove steering wheel.
2. Remove dash assembly.
3. Install wiring harness and toggle switch. Position the switch so the slot in the threads is toward the rear of the tractor. Attach the wiring according to the drawings below.
4. Connect dark green wire from toggle switch to ground on the mounting hardware of the voltage regulator and connect black wire to terminal board.

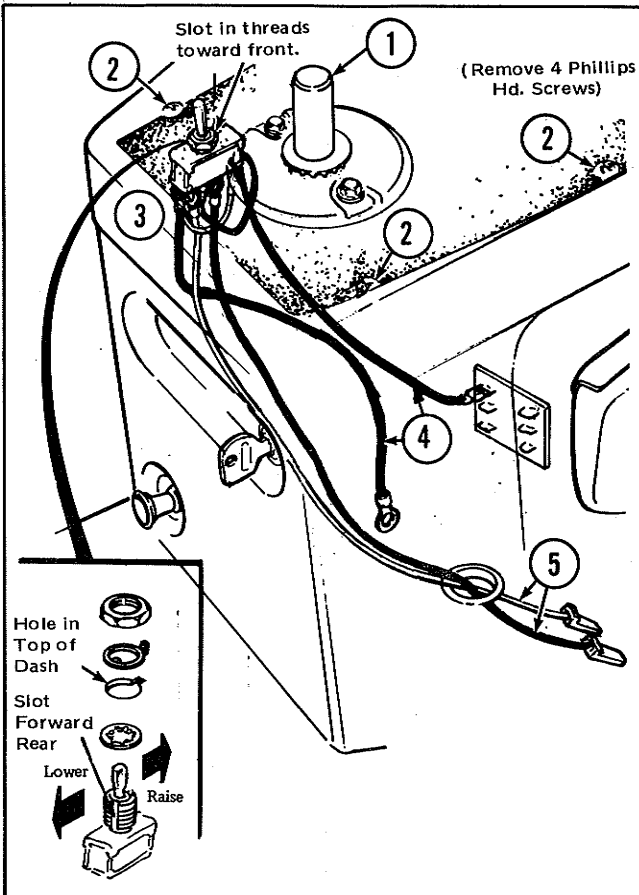

5. Drop red and yellow wire through the hole in the frame.
6. Attach the power lift support assembly to the underside of the frame with (4) Hex Capscrews, 3/8"-16 x 5/8" lg. and (4) 3/8" Lockwashers.
7. Slip the studs of the power lift assembly into the curved slots of the power lift support assembly.
8. Secure the power lift assembly to the power lift support assembly with 1 Hex Capscrew, 5/16-18 x 3-1/4" lg. and 1 Hex Nut, full lock 5/16-18.
9. Secure the ram of the power lift assembly to the ears of the tractor lift shaft with 1 pin and 2 cotter pin, 3/32 x 3/4" lg.
10. Connect the red wire of the power lift assembly to the red wire of the harness assembly. Do the same with the yellow wire. **NOTE:** Some power lift assemblies will be equipped with black and red wires if this is the case connect the Red wire to the Yellow wire on the harness, and the Black to the Red on the harness - Tape both ends.

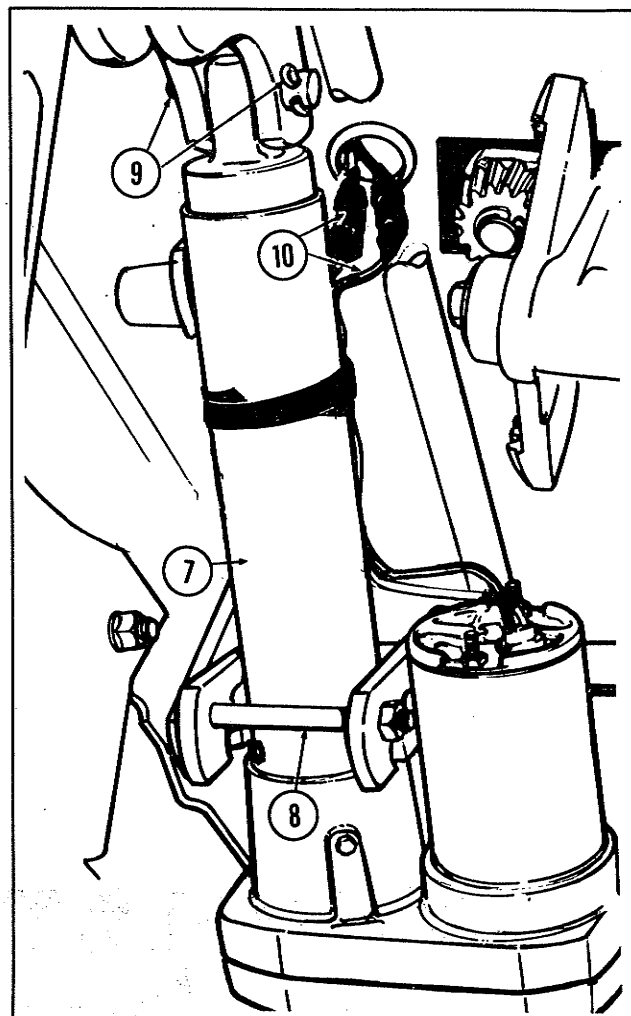
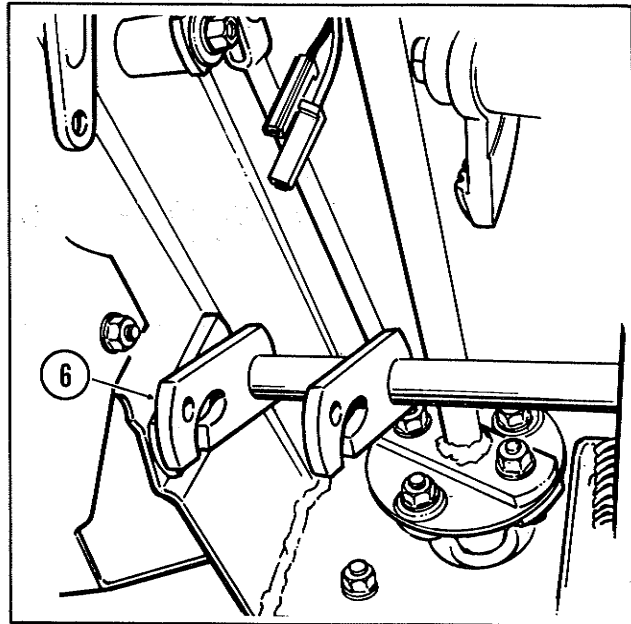

CAUTION

DO NOT OPERATE LIFT UNTIL ALL 12 STEPS OF INSTALLATION HAVE BEEN COMPLETED.

POWER LIFT KIT

MFG. NO. 1690043 POWER LIFT KIT

PARTS MANUAL

POWER LIFT KIT
MFG. NO. 1690043

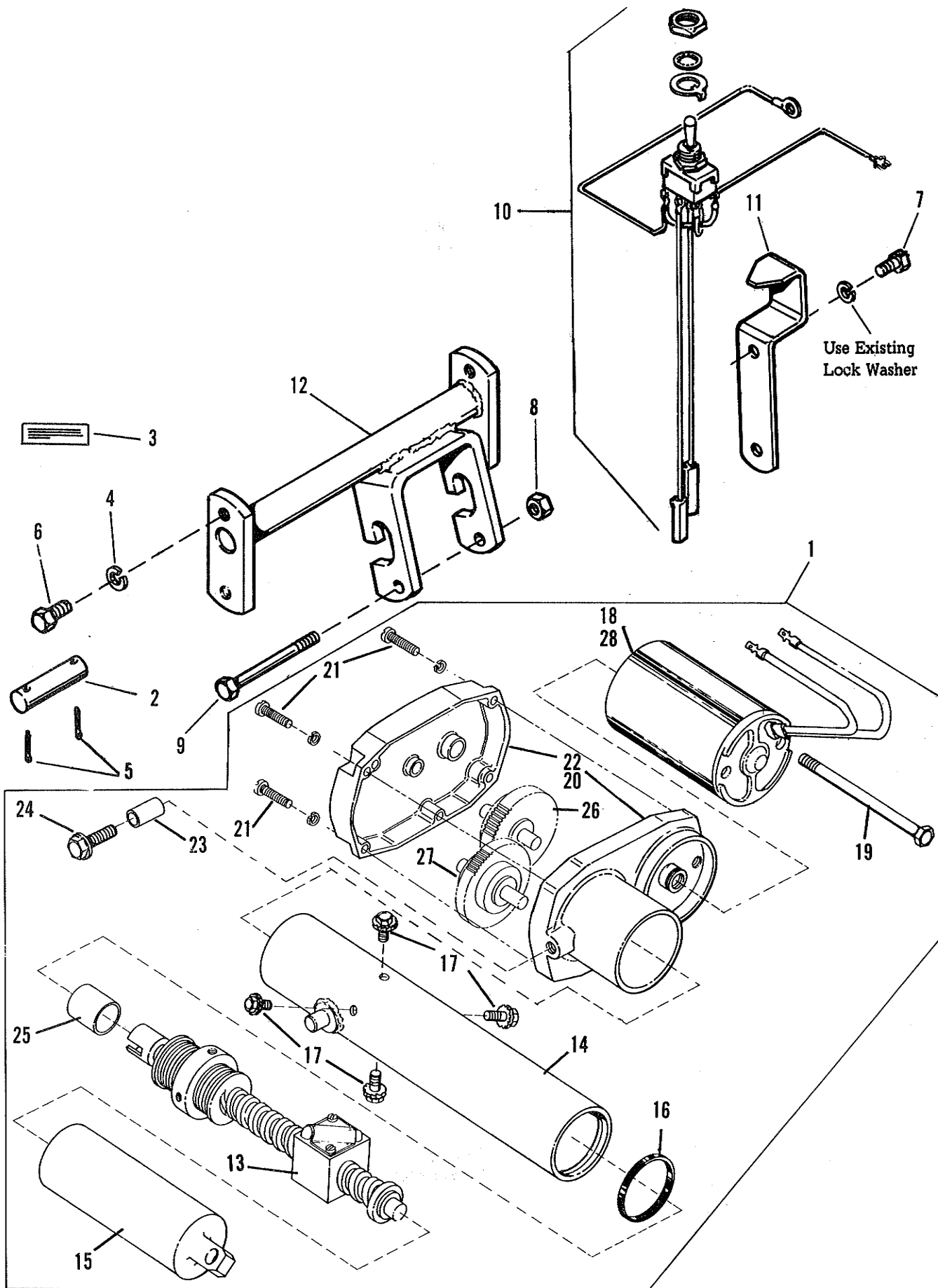

**POWER LIFT KIT
MFG. NO. 1690043**

| Ref. No. | Part No. | Qty. | Description |
|----------|----------|------|--------------------------------|
| 1 | 170454 | 1 | LIFT ASSY., POWER |
| 2 | 171025 | 1 | PIN |
| 3 | 175527 | 1 | FILM, Lift Control |
| 4 | 916965 | 4 | LOCKWASHER, 3/8 |
| 5 | 918447 | 2 | PIN, Cotter, 3/32, x 3/4 |
| 6 | 922586 | 6 | CAPSCREW, Hex, 3/8-16 x 5/8 |
| 7 | 923299 | 2 | CAPSCREW, Hex, 3/8-16 x 1/2 |
| 8 | 923362 | 1 | LOCKNUT, full hex, 5/16-18 |
| 9 | 926106 | 1 | CAPSCREW, Hex, 5/16-18 x 3-1/4 |
| 10 | 1651166 | 1 | SWITCH & HARNESS |
| 11 | 1652736 | 1 | POINTER, Stop |
| 12 | 1652747 | 1 | SUPPORT ASSY., Pump |

| Ref. No. | Part No. | Qty. | Description |
|----------|----------|------|-----------------------|
| 13 | 173697 | 1 | BEARING, Ball |
| 14 | 173698 | 1 | TUBE ASSY., Outer |
| 15 | 173699 | 1 | TUBE ASSY., Inner |
| 16 | 1605772 | 1 | SEAL |
| 17 | 1605775 | 4 | SCREW, Thread cutting |
| 18 * | 1605776 | 1 | MOTOR |
| 19 | 1605777 | 2 | SCREW |
| 20 * | 1651819 | 1 | HOUSING |
| 21 | 1605780 | 4 | SCREW, Filister |
| 22 * | 173702 | 1 | HOUSING |
| 23 | 1605778 | 1 | PIN, Drive |
| 24 | 1605773 | 1 | SCREW, Thread forming |
| 25 | 1605779 | 1 | SLEEVE, Coupling |
| 26 | 173700 | 1 | GEAR ASSY. |
| 27 | 173701 | 1 | GEAR ASSY. |
| 28 * | 1651818 | 1 | MOTOR |

NOTE: Some power lift assemblies will be equipped with one of two motors. Numbers for the existing motor and housing will be determined by the color of wires off of the motor. A red and yellow wire will identify your motor as 1605776. A red and black wire will identify your motor as 1651818. Make sure motor 1651818 is used with housing 1651819. Motor 1605776 should be used with housing 173702.

IMPORTANT: These parts are Not interchangeable.

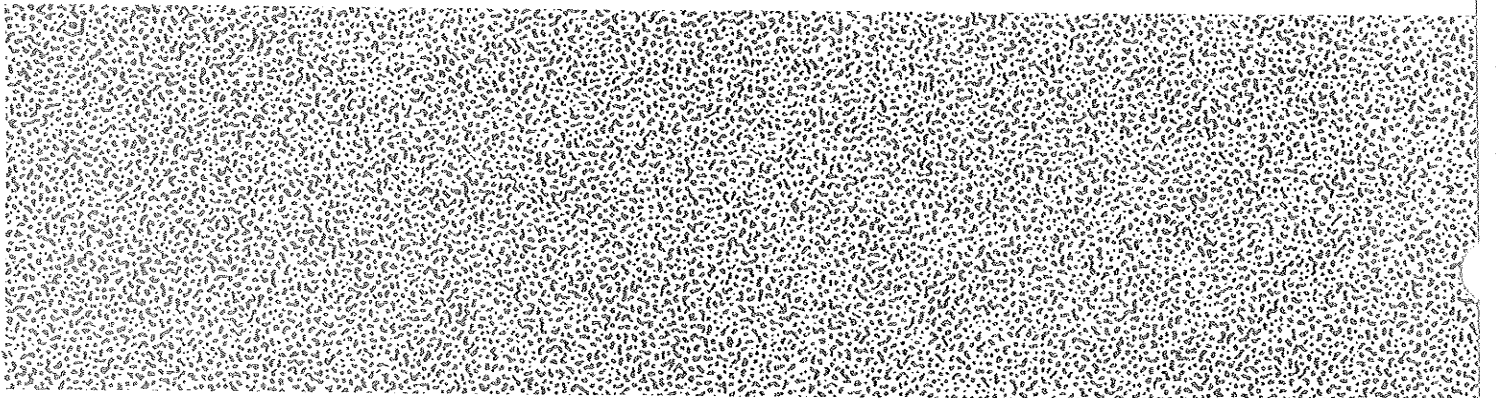

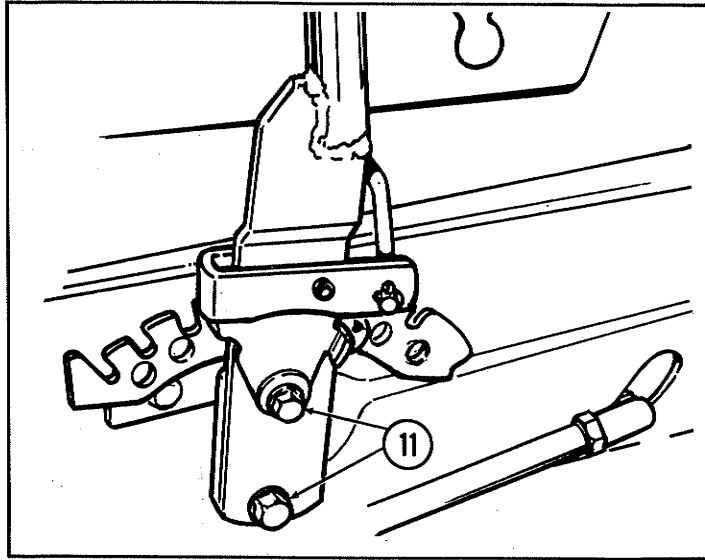

11. Remove the lift lever assembly.

12. Replace the lift lever assembly with the pointer and secure with 2 Hex Capscrews, 3/8"-16 x 1/2" lg. and old lockwashers.

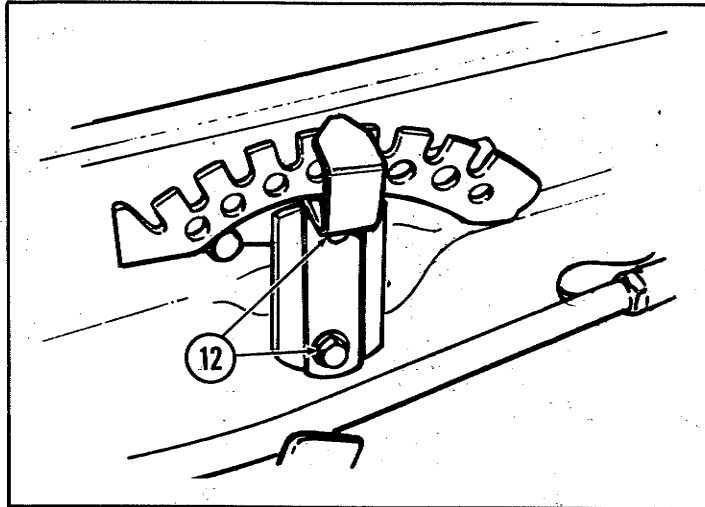

MFG. NO. 1690043 POWER LIFT KIT

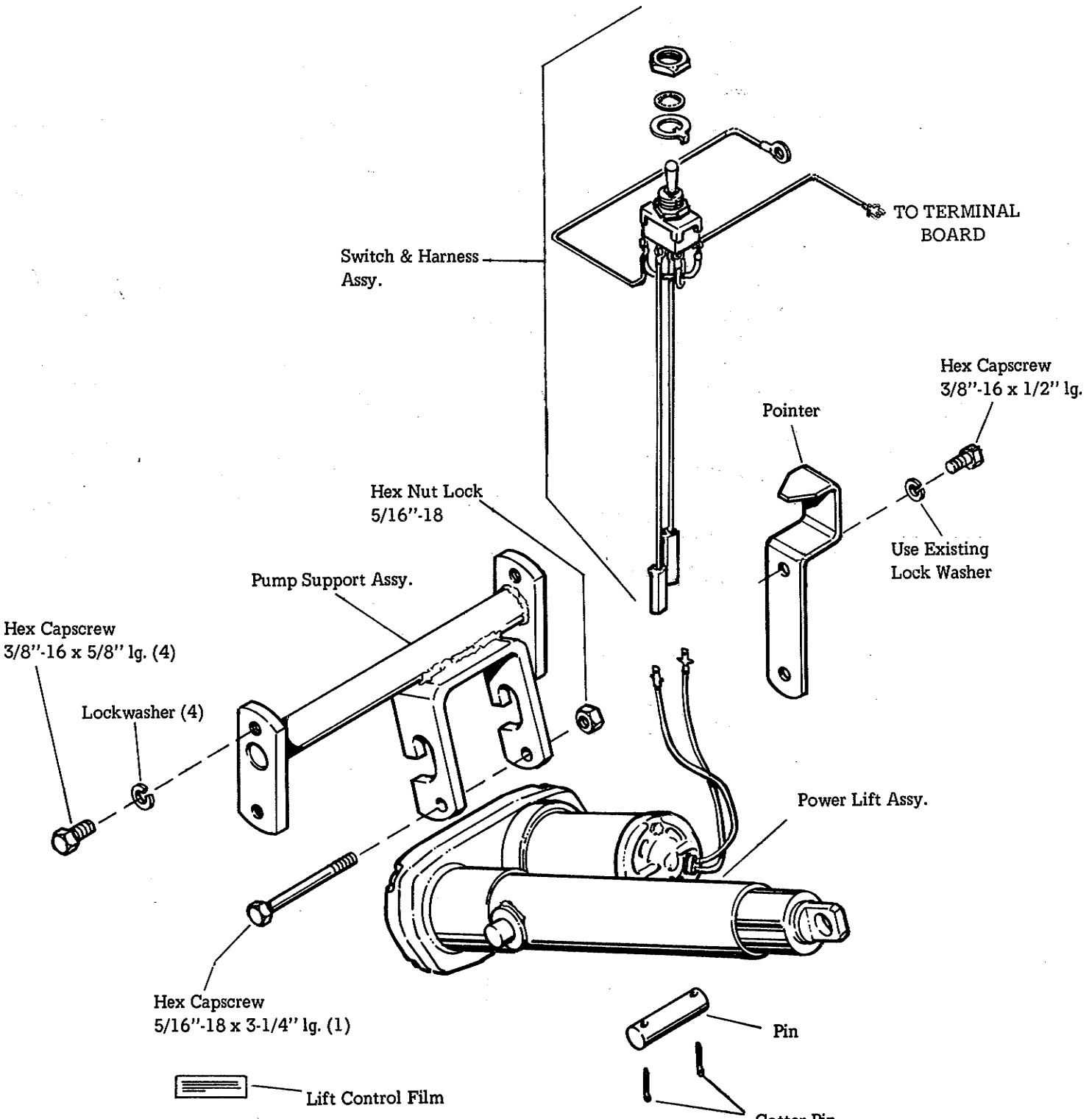

SPECIFICATIONS SUBJECT TO CHANGE WITHOUT NOTICE

Cotter Pin
3/32"x3/4" lg.