

brother®

Please read this manual thoroughly before using the printer.

Brother Laser Printer for Windows™

WL-660 Series

User's Guide

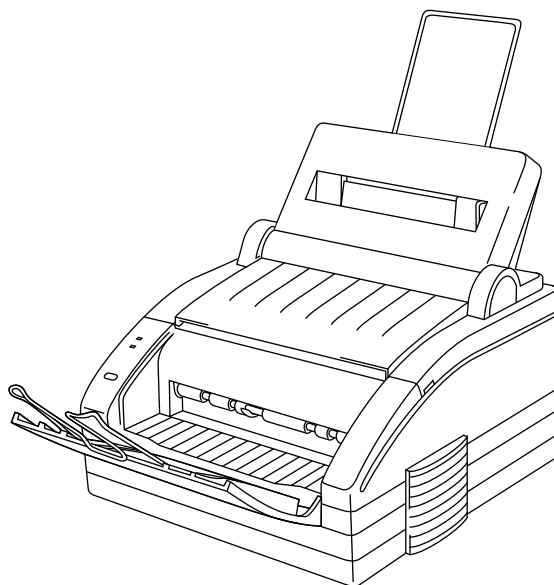

Keep this manual in a convenient place for quick and easy reference at all times.

Shipment of the Printer

If for any reason you must ship your Printer, carefully package the Printer to avoid any damage during transit. It is recommended that you save and use the original packaging. The Printer should also be adequately insured with the carrier.

Warning

When shipping the Printer, the DRUM UNIT assembly including the TONER CARTRIDGE must be removed from the Printer and placed in the plastic bag. **Failure to remove and place it in the plastic bag during shipping will cause severe damage to the Printer and will VOID THE WARRANTY.**

1 Remove the drum unit.

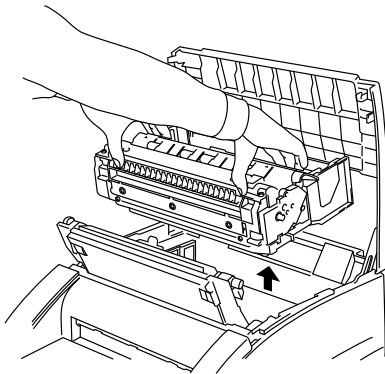

2 Place it in the plastic bag and fold the plastic bag under the drum unit.

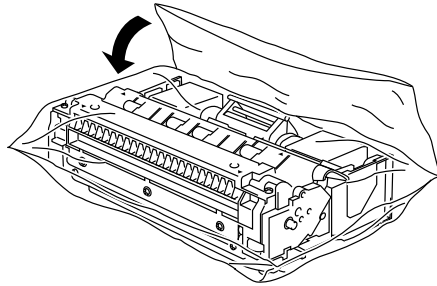

3 Wrap it in the corrugated cardboard.

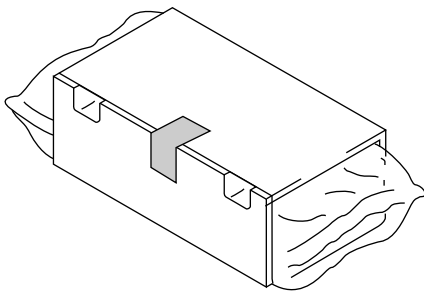

4 Re-pack the printer.
See "RE-PACKING THE PRINTER" in Chapter 5.

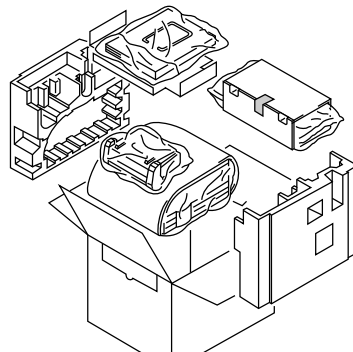



Laser Printer WL-660 Series for Windows®

User's Guide

(For USA & CANADA Only)

For technical and operational assistance, please call:

In USA	1-800-276-7746	(outside California)
	714-859-9700 Ext. 329	(within California)
In Canada	1-800-361-6466	

If you have comments or suggestions, please write us at:

In USA	Printer Customer Support Brother International Corporation 15 Musick Irvine, CA 92718
In Canada	Brother International Corporation, Ltd. 1, Rue Hôtel De Ville Dollard-des-Ormeaux P.Q. Canada H9B3H6

BBS

For downloading drivers from our Bulletin Board Service, call 1-714-859-2610. Please log on to our BBS with your first name, last name and a four digit number for your password. Our BBS supports modem speeds up to 14,400, 8 bits no parity, 1 stop bit.

DEALERS/SERVICE CENTERS

For the name of an authorized dealer or service center, call 1-800-284-4357.

USER'S GUIDE

Trademarks

The brother logo is registered trademark of Brother Industries, Ltd.

TrueType is a trademark of Apple Computer, Inc.

IBM and IBM PC are registered trademarks of International Business Machines Corporation.

Microsoft and MS-DOS are registered trademarks of Microsoft Corporation. Windows is a registered trademark of Microsoft in the U.S. and other countries.

All other brand and product names mentioned in this User's Guide are registered trademarks of their respective companies.

Compilation and Publication Notice

Under the supervision of Brother Industries Ltd., this manual has been compiled and published, covering the latest product descriptions and specifications.

The contents of this manual and the specifications of this product are subject to change without notice.

Brother reserves the right to make changes without notice in the specifications and materials contained herein and shall not be responsible for any damages (including consequential) caused by reliance on the materials presented, including but not limited to typographical and other errors relating to the publication.

©1995 Brother Industries Ltd.

Definitions of Warnings, Cautions, and Notes

The following conventions are used in this User's Guide:



Warning

Indicates warnings that must be observed to prevent possible personal injury.



Caution

Indicates cautions that must be observed to use the printer properly or prevent damage to the printer.



Note

Indicates notes and useful tips to remember when using the printer.

To Use the Printer Safely



Warning

After you have used the printer, some internal parts of the printer are extremely hot. When you open the top cover of the printer, never touch the shaded parts shown in the following diagram.

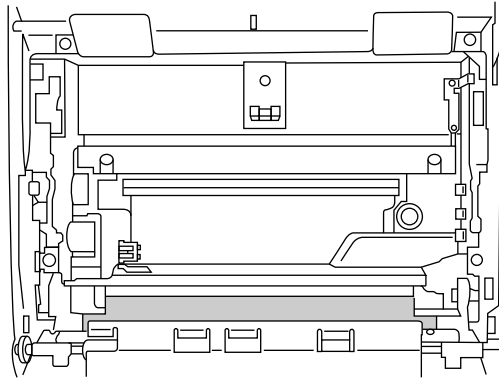

Inside the printer



Warning

Before cleaning the printer, unplug the power cord.

TABLE OF CONTENTS

REGULATIONS vi

CHAPTER 1 INTRODUCTION

ABOUT THE GUIDEBOOKS	1-1
Learning How to Use the Printer	1-1
ABOUT YOUR PRINTER	1-2
Printer Overview	1-2
System Requirements	1-3
Features	1-3
OPERATING AND STORAGE ENVIRONMENT	1-5
Power Supply	1-5
Environment	1-5

CHAPTER 2 PAPER HANDLING

PAPER SPECIFICATIONS	2-1
MULTI-PURPOSE SHEET FEEDER	2-4
MANUAL FEED SLOT	2-8
OUTPUT TRAY AND PAPER SUPPORT WIRE	2-9

CHAPTER 3 PRINTER CONTROL

CONTROL PANEL	3-1
Lamps	3-1
READY Lamp	3-1
ALARM Lamp	3-1
READY↔SLEEP Switch	3-2
Sleep Mode	3-2
Test Page	3-3
SETUP DIALOG BOX	3-4
Paper	3-6
Duplex	3-7
Half Tone	3-7
Printer Configuration	3-8
Quality	3-8

CHAPTER 4 OPTIONS

MEMORY BOARD	4-1
--------------	-----

CHAPTER 5 MAINTENANCE

- REPLACING THE TONER CARTRIDGE 5-1
- REPLACING THE DRUM UNIT 5-6
- ADJUSTING THE PRINT DENSITY 5-10
- CLEANING THE PRINTER 5-11
 - Cleaning the Printer Exterior 5-11
 - Cleaning the Printer Interior and Drum Unit 5-12
- RE-PACKING THE PRINTER 5-15

CHAPTER 6 TROUBLESHOOTING

- ALARM INDICATIONS AT A GLANCE 6-1
 - Operator Calls 6-1
 - Service Calls 6-2
- PAPER JAMS 6-3
- Q & A 6-7
 - Setting up the Printer Hardware and Software 6-7
 - Paper Handling 6-8
 - Printing 6-8
 - Print Quality 6-9

APPENDICES

- PRINTER SPECIFICATIONS Appendix-1
 - Printing Appendix-1
 - Functions Appendix-1
 - Electrical and Mechanical Appendix-2
- PARALLEL INTERFACE SPECIFICATION Appendix-3

INDEX Index-1

REGULATIONS

Federal Communications Commission Compliance Notice (For USA Only)

This equipment has been tested and found to comply with the limits for a Class B digital device, pursuant to Part 15 of the FCC Rules. These limits are designed to provide reasonable protection against harmful interference in a residential installation. This equipment generates, uses, and can radiate radio frequency energy and, if not installed and used in accordance with the instructions, may cause harmful interference to radio communications. However, there is no guarantee that interference will not occur in a particular installation. If this equipment does cause harmful interference to radio or television reception, which can be determined by turning the equipment off and on, the user is encouraged to try to correct the interference by one or more of the following measures:

- Reorient or relocate the receiving antenna.
- Increase the separation between the equipment and receiver.
- Connect the equipment into an outlet on a circuit different from that to which the receiver is connected.
- Consult the dealer or an experienced radio/TV technician for help.

Important – About the Interface Cable

This printer has been certified to comply with FCC standards, which are applied to the U.S.A. only. A shielded interface cable should be used according to FCC 15.27(C). In addition, a grounded plug should be plugged into a grounded AC outlet after checking the rating of the local power supply for the printer to operate properly and safely.

Caution

Changes or modifications not expressly approved by Brother Industries, Ltd. could void the user's authority to operate the equipment.

Laser Safety (For 110–120 V Model Only)

This printer is certified as a Class I laser product under the U.S. Department of Health and Human Services (DHHS) Radiation Performance Standard according to the Radiation Control for Health and Safety Act of 1968. This means that the printer does not produce hazardous laser radiation.

Since radiation emitted inside the printer is completely confined within protective housings and external covers, the laser beam cannot escape from the machine during any phase of user operation.

FDA Regulations (For 110-120 V Model Only)

U.S. Food and Drug Administration (FDA) implemented regulations for laser products manufactured from August 2, 1976. These regulations apply to laser products manufactured from August 1, 1976. Compliance is mandatory for products marketed in the United States. The label shown on the back of the printer indicates compliance with the FDA regulations and must be attached to laser products marketed in the United States.

MANUFACTURED:
 BROTHER INDUSTRIES, LTD.
 15-1 Naeshiro-cho Mizuho-ku Nagoya, 467 Japan
 This product complies with FDA radiation performance standards, 21 CFR
 chapter 1 subchapter J

Caution

Use of controls, adjustments or performance of procedures other than those specified in this manual may result in hazardous invisible radiation exposure.

DECLARATION OF CONFORMITY (EUROPE)

We, Brother International Europe Ltd.,
 Brother House 1 Tame Street, Guide Bridge, Audenshaw, Manchester M34 5JE, UK.

declare that this products is in conformity with the following normative documents.

Safety:	EN 60950,	EN 60825
EMC:	EN 55022 Class B,	EN 50082-1

following the provisions of the Low Voltage Directive 73/23/EEC and the Electromagnetic Compatibility Directive 89/336/EEC (as amended by 91/263/EEC and 92/31/EEC).

Manufacture at the following facilities is carried out under a Quality System which is registered by BSI Quality Assurance and JQA Quality Assurance.

Brother Industries Ltd., Kariya Plant
 1-5, Kitajizoyama, Noda-cho, Kariya-shi,
 Aichi-ken 448, Japan
 BSI Certificate of Registration No. FM27391
 JQA Certificate of Registration No. 0340

Issued by:
 Brother International Europe Ltd.
 European Development and Technical Services Division

USER'S GUIDE

IEC 825 Specification (For 220–240 V Model Only)

This printer is a Class 1 laser product as defined in IEC 825 specifications. The label shown below is attached in countries where required.



This printer has a Class 3B Laser Diode which emits invisible laser radiation in the Scanner Unit. The Scanner Unit should not be opened under any circumstances.

Caution

Use of controls, adjustments or performance of procedures other than those specified in this manual may result in hazardous radiation exposure.

The following caution label is attached near the scanner unit.

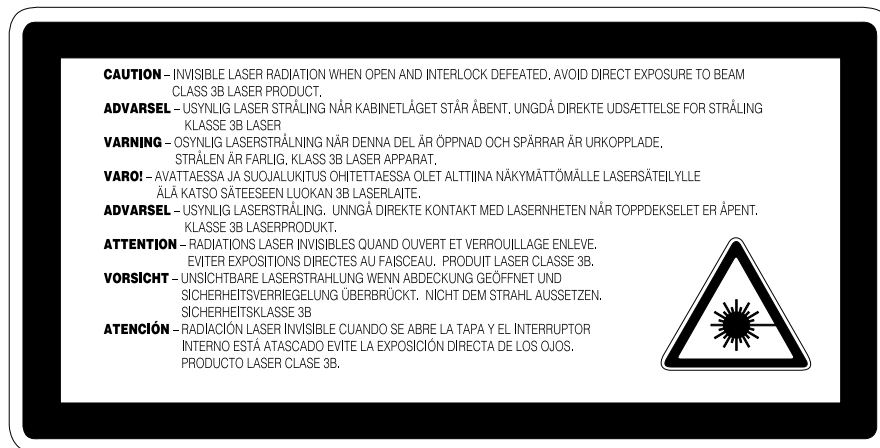

**For Finland and Sweden
LUOKAN 1 LASERLAITE
KLASS 1 LASER APPARAT**

Varoitus! Laitteen käyttäminen muulla kuin tässä käyttöohjeessa mainitulla tavalla saattaa altistaa käyttäjän turvallisuusluokan 1 ylittävälle näkymättömälle lasersäteilylle.

Varning – Om apparaten används på annat sätt än i denna Bruksanvisning specificerats, kan användaren utsättas för osynlig laserstrålning, som överskrider gränsen för laserklass 1.

For Your Safety

To ensure safe operation, the three-pin plug supplied must be inserted only into a standard three-pin power point which is effectively grounded through the normal household wiring.

Extension cords used with the equipment must be three-conductor and be correctly wired to provide connection to ground. Incorrectly wired extension cords are a major cause of fatalities.

The fact that the equipment operates satisfactorily does not imply that the power is grounded and that the installation is completely safe. For your safety, if in any doubt about the effective grounding of the power, consult a qualified electrician.

Disconnect device

The equipment must be installed near the socket outlet which must be easily accessible.

Manufactured at

Brother Industries Ltd.
Kariya Plant
1-5, Kitajizoyama, Noda-cho, Kariya-shi, Aichi-ken 448, Japan.

Manufacturing at Kariya Plant is carried out under a Quality System which is registered by JQA Quality Assurance and BSI Quality Assurance.

JQA Certificate of Registration No. 0340. BSI Certificate of Registration No. FM27391
--

Canadian Department of Communications Compliance Statement

This digital apparatus does not exceed the Class B limits for radio noise emissions from digital apparatus as set out in the interference-causing equipment standard entitled "Digital Apparatus", ICES-003 of the Department of Communications.

IMPORTANT (For U.K. only)

If the power cord supplied with this printer is not suitable for your electrical outlet, remove the plug from the mains cord and fit an appropriate three pin plug. If the replacement plug is intended to take a fuse then fit the same fuse as the original.

If a moulded plug is severed from the power cord then it should be destroyed because a plug with cut wires is dangerous if plugged into a live socket outlet. Do not leave it where a child might find it.

In the event of replacing the plug fuse, fit a fuse approved by ASTA to BS1362 with the same rating as the original fuse.

Always replace the fuse cover. Never use a plug with the cover omitted.

WARNING - THIS PRINTER MUST BE PROPERLY EARTHED.

The wires in the mains cord are coloured in accordance with the following code:

Green and yellow :	Ground
Blue :	Neutral
Brown :	Live

The colours of the wiring in the power lead of this printer may not correspond with the markings which identify the terminals in your plug. If you need to fit a different plug, proceed as follows.

USER'S GUIDE

Remove a length of the cord outer sheath, taking care not to damage the coloured insulation of the wires inside.

Cut each of the three wires to the appropriate length. If the construction of the plug permits, leave the green and yellow wire longer than the others so that, in the event that the cord is pulled out of the plug, the green and yellow wire will be the last to disconnect.

Remove a short section of the coloured insulation to expose the wires.

The wire which is coloured green and yellow must be connected to the terminal in the plug which is marked with the letter "E" or by the earth symbol or coloured green or green and yellow.

The wire which is coloured blue must be connected to the terminal which is marked with the letter "N" or coloured black or blue.

The wire which is coloured brown must be connected to the terminal which is marked with the letter "L" or coloured red or brown.

The outer sheath of the cord must be secured inside the plug. The coloured wires should not hang out of the plug.

CHAPTER 1 INTRODUCTION

ABOUT THE GUIDEBOOKS

Learning How to Use the Printer

You have two guidebooks for this printer. Read each guidebook in the following order:

1. Read the Quick Setup Guide to set up your printer and connect it to your computer. It also contains information about setting up your computer for your printer by installing the printer driver, fonts and Remote Printer Console Program.
2. Read the User's Guide to get information about the following:
 - Features and operating environment requirements of your printer – Chapter 1
 - Paper Handling – Chapter 2
 - Printer Control – Chapter 3
 - Options – Chapter 4
 - Maintenance – Chapter 5
 - Troubleshooting – Chapter 6
 - Specifications – Appendices
 - Index

ABOUT YOUR PRINTER

Printer Overview

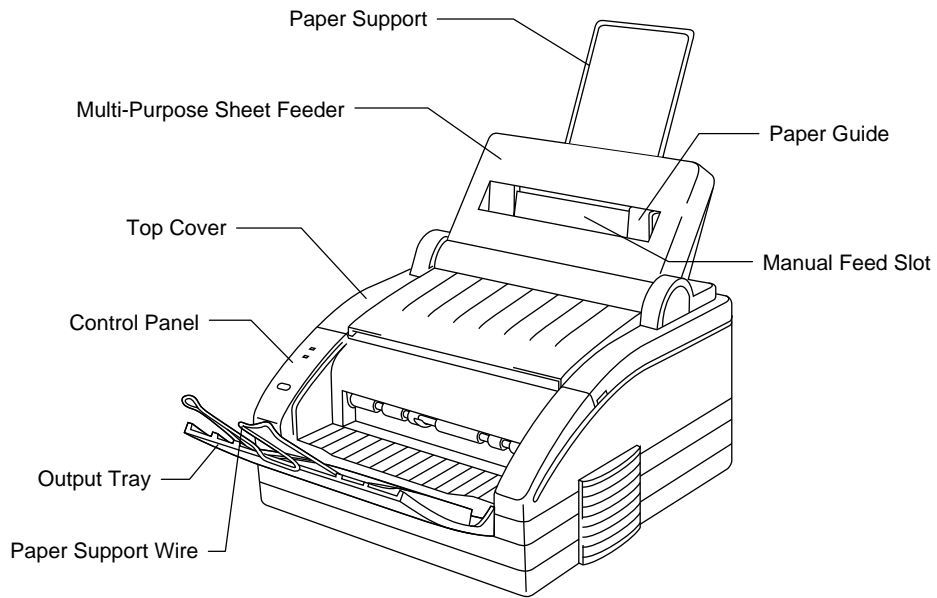

Fig. 1-1 Front View

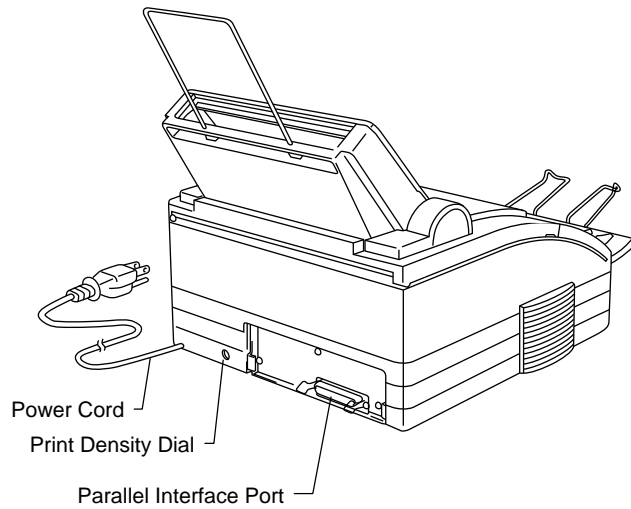

Fig. 1-2 Rear View

System Requirements

Check the following system requirements to setup and operate the printer:

- IBM PC or compatible with 80486 SX or higher microprocessor
- Parallel interface (or printer port)
- 4 MB or more of memory
- 10 MB of space available on your hard disk for the printer driver and all fonts
- Microsoft Windows 3.1/3.11

⚠ Caution

This printer has been designed specially for Windows 3.1. It cannot work in a DOS environment, such as MS-DOS.

Features

This printer has the following features:

- ❑ **600 dpi Resolution and 6 ppm Printing Speed**
600 dots per inch (dpi) with microfine toner and six pages per minute (ppm) printing speed (A4 or Letter size paper).
- ❑ **User-Friendly Operation for Windows**
The dedicated printer driver and TrueType™-compatible fonts for Microsoft® Windows 3.1 are available on the floppy disk supplied with your printer. You can easily install them into your Windows system using our installer program. The driver supports our unique compression mode to enhance printing speed in Windows applications and allows you to set various printer settings including toner savings mode, custom paper size, sleep mode, gray scale adjustment, resolution and so forth. You can easily set these print options in the graphic dialog boxes through Printer Setup within Windows Control Panel.
- ❑ **Printer Status Monitor with Bi-directional Parallel Interface**
The printer driver can monitor your printer's status using bi-directional parallel communications.

The program can show the current status of your printer. When printing, the animated dialog box appears on your computer screen to show the current printing process. If an error occurs, a dialog box will appear to let you know what to correct. For example: when your printer is out of paper, the dialog box will display "Paper Empty" and instructions for the corrective action to take.

USER'S GUIDE

❑ **Versatile Paper Handling**

The printer has a multi-purpose sheet feeder and straight paper path. Using this mechanism, you can load A4, letter, legal, B5, A5, and executive sizes of paper, as well as various other paper sizes including envelopes, postcards, organizer paper, or a custom paper size.

The multi-purpose sheet feeder also allows manual paper loading for printing labels and transparencies.

❑ **APT (Advanced Photoscale Technology)**

The APT feature of the printer driver allows you to print photographs with photographic quality output.

❑ **Auto Resolution Reduction**

When a printout is requested in 600 dpi mode with the standard amount of printer memory, the printer might not be able to print at 600 dpi due to insufficient memory. To prevent this memory error, the printer driver automatically reduces the resolution to 300 dpi or less for successful printing.

❑ **Environment-Friendly, Economy Printing Mode**

This feature will cut your printing cost by saving toner. It is useful to obtain draft copies for proof-reading. You can select from two economy modes—25% toner saving and 50% toner saving—through the Windows printer driver supplied with your printer.

❑ **Sleep Mode**

Sleep mode automatically reduces power consumption when the printer is not in use. The printer consumes less than 8W when in sleep mode. The time-out for auto sleep mode can be set through the Windows printer driver.

❑ **Low Running Cost**

The toner cartridge is separate from the drum unit. Each toner cartridge will give you approximately 3,000 pages, which is cost effective and ecologically friendly. (In some areas the printer is supplied with a starter toner cartridge which must be replaced after 1,000 pages.)

OPERATING AND STORAGE ENVIRONMENT

Please take note of the following before using the printer:

Power Supply

Use the printer within the specified power range.

AC power: $\pm 10\%$ of the rated power voltage in your district

Frequency: 50 Hz (220 V– 240 V) or 60 Hz (110–120 V)

The power cord, including extensions, should not exceed 5 meters (16.5 feet).

Do not share the same power circuit with other high-power appliances. Particularly an air conditioner, copier, shredder etc. If using the printer with these appliances is unavoidable, we recommend that you use a voltage transformer or a high-frequency noise filter.

Use a voltage regulator if the power source is not stable.

Environment

The printer should be installed near a power outlet, which is easily accessible.

Use the printer only within the following ranges of temperature and humidity:

Ambient temperature: 10°C to 32.5°C (59°F to 90.5°F)

Ambient humidity: 20% to 80% (without condensation)

Ventilate the room where you use the printer.

Place the printer on a flat, horizontal surface.

Keep the printer clean. Do not place the printer in a dusty place.

Do not block the ventilation hole of the printer.

Do not place the printer where it is exposed to direct sunlight. Use a blind or heavy curtain to protect the printer from direct sunlight when the printer is unavoidably set up near a window.

Do not place the printer near devices that contain magnets or generate magnetic fields.

Do not subject the printer to strong physical shocks or vibrations.

Do not expose the printer to open flames or salty or corrosive gasses.

Do not place objects on top of the printer.

Do not place the printer near an air conditioner.

Keep the printer horizontal when carrying.

USER'S GUIDE

CHAPTER 2 PAPER HANDLING

PAPER SPECIFICATIONS

The printer can handle paper that conforms to the following specifications:

Paper Type	Paper Size	Paper Weight	Sheet Feeder	Manual Feeder
Cut sheet	A4, Letter, Legal, B5, A5, Executive, Custom size 70-216 x 127-356 mm, 2.75"-8.5" x 5"-14"	60-135 g/m ² (16-36 lb.)	●	●
Envelopes	DL, C5, COM-10, Monarch		●	●
Organizer	Day-Timer [®] J, K, L, M 70-216 x 127-356 mm 2.75"-8.5" x 5"-11"		●	●
Labels Transparencies	70-216 x 127-356 mm, 2.75"-8.5" x 5"-14"			●

Paper Capacity in Feeder

Multi-purpose

Sheet Feeder : Up to 22 mm (0.87 inch) in Height (below the mark ▼.)
Approx. 200 sheets of 75 g/m² (20 lb.) A4/Letter paper or 10 envelopes

Output Tray : Approx. 100 sheets of 75 g/m² (20 lb.) A4/Letter paper

Remarks

It is recommended that you test paper, especially special sizes and types of paper, on this printer before purchasing large quantities.

Avoid feeding labels with carrier sheets exposed or your printer will be damaged. **Do not feed label sheets through the printer more than once.**

Use a recommended type of paper, especially plain paper and transparencies, for optimum printing. For more information on paper specifications, consult your nearest authorized sales representative or the place where you purchased your printer.

We recommend you use labels or transparencies which are designed for laser printers.

We recommend you use long-grained paper for the best print quality.

If the paper will not load from the multi-purpose sheet feeder, use the manual feed slot and try again.

USER'S GUIDE

Before using paper with holes such as organizer sheets, you must fan the stack well to avoid paper jams and misfeeds.

Before using any paper, make sure that it is not curled. If so, you should straighten the paper as much as possible. Feeding curled paper will cause paper jams and misfeeds.



Fig. 2-1 Fan the Paper and Straighten the Paper

The following types of envelopes are not recommended for use:

- Damaged, curled, wrinkled, or irregularly shaped envelopes
- Extremely shiny or highly textured envelopes
- Envelopes with clasps
- Envelopes of baggy construction
- Envelopes not sharply creased
- Embossed envelopes
- Envelopes already printed with a laser printer
- Envelopes pre-printed on the inside
- Envelopes that cannot be arranged uniformly when placed in a pile

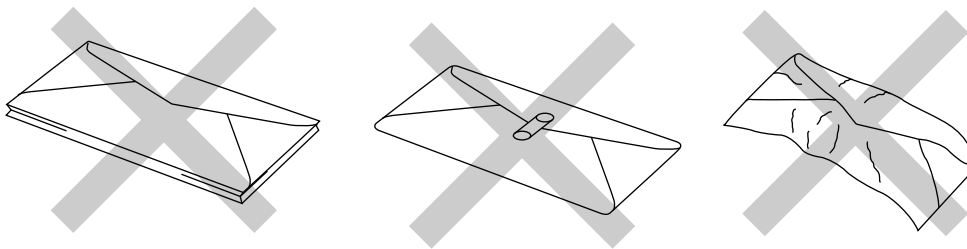
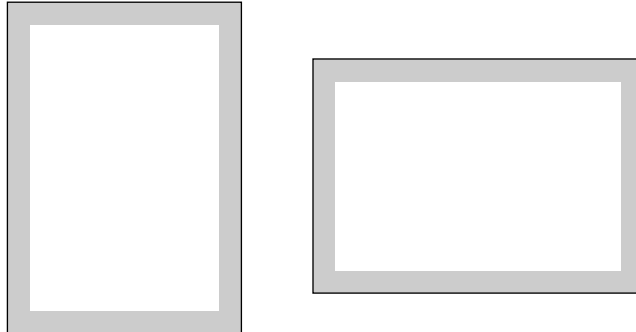

Fig. 2-2 Envelopes

Printable Area

The figure below shows the physical printable area.



□ Unprintable area
Approximately 4 mm (0.16 inch) from each edge for all sizes of paper

Fig. 2-3 Printable Area

MULTI-PURPOSE SHEET FEEDER

The printer has a multi-purpose sheet feeder that can feed plain paper, envelopes and organizer paper.

 **Caution**

When you use labels or transparencies for overhead projectors, be sure to use the manual feed slot. See the next section “MANUAL FEED SLOT” for more details.

To use the multi-purpose sheet feeder, follow these steps:

1. Make sure that you have selected the proper paper source, paper size and orientation in your software applications and/or the Windows printer driver.

 **Note**

If your application software does not support your custom paper size, select the next paper size up that is closest but larger than the custom size. Then adjust the print area by changing right and left margins in your application software.

2. Make sure that the multi-purpose sheet feeder contains the selected size of paper in the selected orientation. If necessary, change the paper in the feeder.
3. Make sure that the multi-purpose sheet feeder is properly placed in the printer.
4. Choose the print command in your software to send a document to the printer.

When the printer receives data, it begins the print process by loading paper from the multi-purpose sheet feeder. If the printer is in sleep mode when it receives data, it wakes up and starts the printing process automatically.

 **Note**

If the paper does not automatically feed, please check the Paper Source settings in the program you are printing from to make sure it is not set to Manual Feed.

Loading Paper into the Feeder

To load paper into the feeder, follow these steps.

1. Open the multi-purpose sheet feeder. (①)
2. Load paper into the multi-purpose sheet feeder with the printing surface face down. (②)

⚠ Caution

- The feeder can hold up to 200 sheets of plain paper. If you load too many sheets, paper jams might occur.
- Make sure that the paper is stacked below the ▼ mark.
- If there is still some paper in the feeder, you must first remove it, put it together with the new paper and then insert the stack into the feeder.

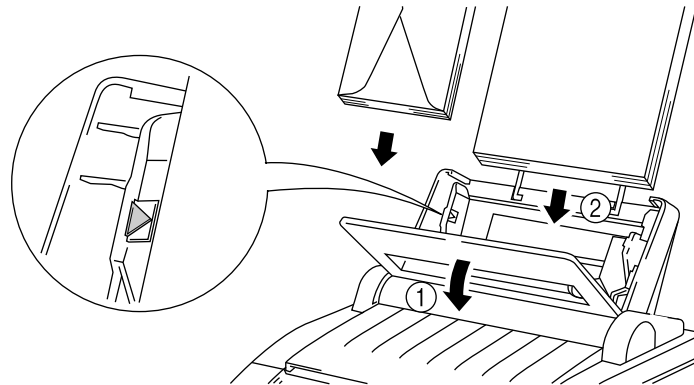

Fig. 2-4 Opening the Feeder and Loading Paper or Envelopes

🔪 Note

If you load envelopes in the feeder, make sure they are inserted in the direction shown above with the flap on the left side.

USER'S GUIDE

3. Move the paper guide to the appropriate paper width. (①)
4. Close the multi-purpose sheet feeder. (②)

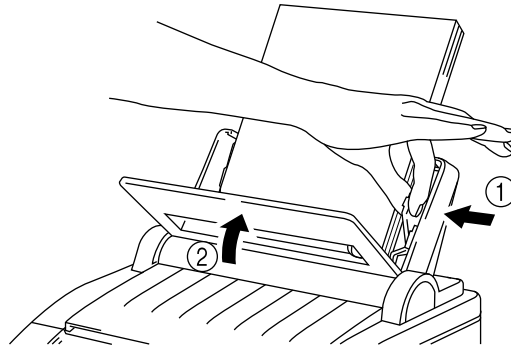

Fig. 2-5 Moving the Paper Guide and Closing the Feeder

Note

If the multi-purpose sheet feeder runs out of paper when you try to print, the ALARM lamp blinks to alert you with a paper empty error. The error status monitor with some instructions appears on your computer screen to inform you of the error status and how to correct it. If you are using Print Manger in Windows, you may need to check to see whether Print Manger registers your Print Job as "stalled". If so, click on "Resume" to continue the print job. Failure to do so may result in inconsistent printing.

Two Side Printing (Manual Duplexing)

The supplied printer driver for Windows 3.1 enables manual duplex printing. For more information about settings, see the help text of the printer driver which can be accessed through the Windows Control Panel.

The printer prints all the even numbered pages on one side of the paper first and then prints all the odd pages on the reverse side of the paper.

When you have finished printing on one side of the paper, the driver instructs you to re-insert the paper by a pop-up message on the computer. Follow the instructions on how to reinsert the paper.

⚠ Caution

- Before re-inserting the paper, you have to straighten it well or you may get paper misfeed errors.
- Use of very thin or very thick paper is not recommended.
- If you find that more than one sheet is fed through at one time, we recommend that you hold all the paper in the sheet feeder except for the front sheet so the printer will feed just one sheet.

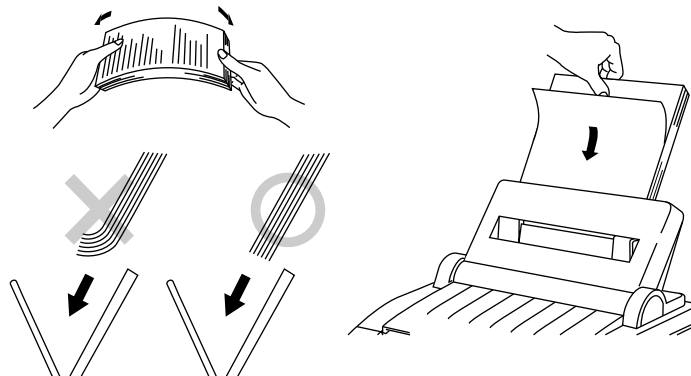

Fig. 2-6 Notes for Manual Duplexing

📌 Note

When you use the Manual Duplex function, it is possible that a paper jam may occur or print quality may not be satisfactory.

MANUAL FEED SLOT

The multi-purpose sheet feeder also has a manual feed slot. You can manually load paper sheet by sheet from this slot. You do not need to remove paper from the multi-purpose sheet feeder when using the manual feed slot.

When you use labels or transparencies, be sure to use the manual feed slot. For information on paper specifications, see “PAPER SPECIFICATIONS” in the previous section.

❑ When you load one sheet of paper manually:

You do not need to choose manual feed in the Setup dialog box of your printer driver. Holding the selected size of paper in the selected orientation (Portrait or Landscape), place the side of the paper you wish to print on face down into the manual feed slot. Align the paper to the left side of the manual feed slot, and be sure to insert it all the way. (①) Move the paper guide of the manual feed slot to the paper width you are using. (②)

❑ When you load more than one sheet of paper manually:

Open the Setup dialog box of your printer driver and choose Manual Feed in the Paper Source section. Follow the above instructions to load the first page. The printer automatically starts printing. After the first page is printed, the dialog box appears and prompts you to load the next page. Load a sheet and choose OK to resume printing. Repeat these steps until you finish printing all pages.

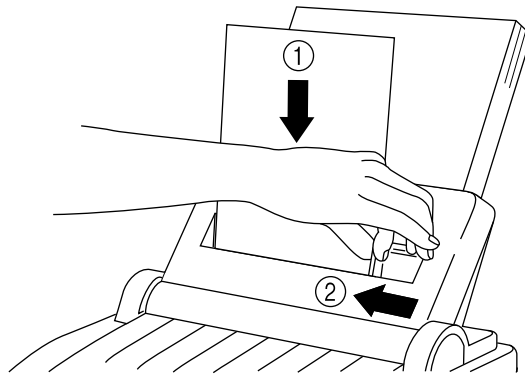

Fig. 2-7 Moving the Paper Guide

Note

- Insert paper firmly into the manual feed slot.
- Be sure to load sheet by sheet when using the manual feed slot.

OUTPUT TRAY AND PAPER SUPPORT WIRE

The printer ejects paper with the printed surface face down into the output tray at the front of the printer.

When the output tray is closed, the ejected paper comes out sheet by sheet through the slit in front. When you open the tray, sheets can be stacked on it.

Follow these steps to open the output tray:

1. Pull the top of the tray down.
2. Extend the paper support wire.

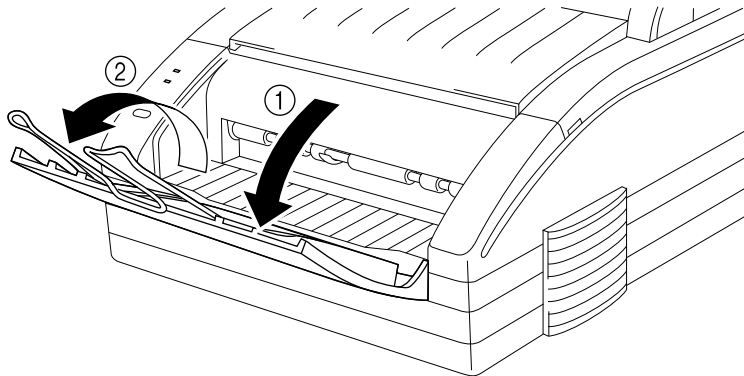

Fig. 2-8 Opening the Output Tray and Extending the Paper Support Wire

You can stack up to 100 sheets in the output tray.

⚠ Caution

- When you use transparencies, remove each sheet immediately after printing. Stacking sheets may cause toner to smear onto the back of the previous sheet.
- When the output tray is closed, you need to remove the ejected sheet or you will get a paper jam when the second sheet is ejected.

USER'S GUIDE

CHAPTER 3 PRINTER CONTROL

CONTROL PANEL

Lamps

This section refers to the following lamps on the printer control panel:

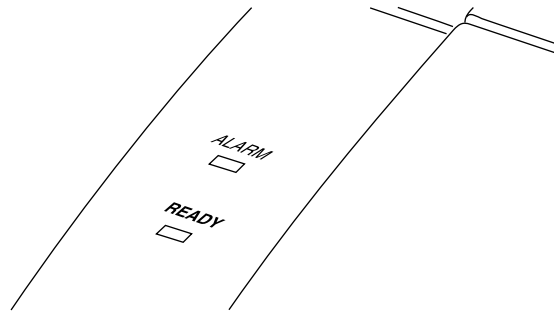

Fig. 3-1 Lamps on Control Panel

Note

When the power cord is not plugged into the AC outlet or the printer is in sleep mode, all lamps including the READY lamp are off.

READY Lamp

The green READY lamp indicates the current status of the printer. The printer will wake up automatically from sleep mode when data is received, a switch is pressed, or when the power cord is plugged in. The list below shows each printer status (● = on, ○ = off):

Lamp	Printer status
Off ○	The power cord is not plugged into the AC outlet or the printer is in the sleep mode.
Blinking ○↔●	The printer is receiving and processing data from the computer. (Blinking at 0.5 seconds intervals)
Blinking ○↔●	The printer is warming up. (Blinking at 1 seconds intervals)
On ●	The printer is on-line.

ALARM Lamp

The red ALARM lamp blinks to indicate a printer error status. If an error occurs, the printer indicates the error by causing the ALARM lamp to blink. At the same time (if your computer is turned on and attached to the printer), the status monitor appears on your computer screen to show you the error message.

READY↔SLEEP Switch

This printer has a READY↔SLEEP switch on the control panel.

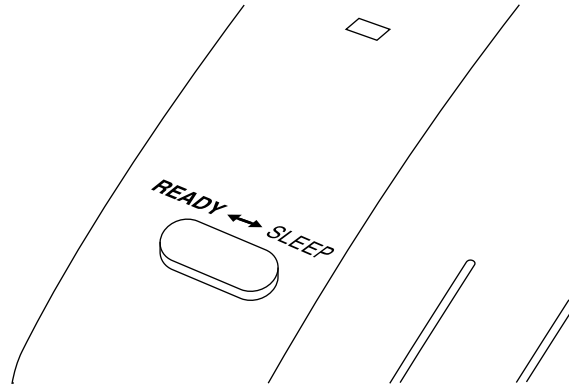

Fig. 3-2 Switch on Control Panel

Note

- This printer has no power switch. You just plug the power cord into the AC outlet. The sleep mode feature controls all power.
- If a recoverable error, such as *cover open* or *paper empty* should occur, take the appropriate action to correct it. The printer should automatically recover from the error without unplugging the printer.

The READY↔SLEEP switch can work in two ways: to enter sleep mode or to print a test page.

Sleep Mode

Sleep mode causes the printer to act as though it has been turned off. While the printer is in sleep mode, all the lamps are off, however the printer can still receive data from the computer.

If you press the READY↔SLEEP switch when the Ready light is a solid green, the printer enters sleep mode.

If you press the READY↔SLEEP switch during printing, the printer immediately stops printing, even if it has started a print job. It ejects the page, then enters sleep mode.

Caution

Remember that the READY↔SLEEP switch clears data from the printer memory and puts the printer into sleep mode.

When the printer is in the Ready mode and the printer does not receive data for a certain period of time (time-out), it automatically enters sleep mode. The default time-out has been factory set for 5 to 15 minutes.

To awaken the printer to Ready status, press the READY↔SLEEP switch again. Receiving a document automatically awakens the printer and causes it to start printing.

 **Note**

- This printer has no power switch. The sleep mode handles the power control.
- When the printer first enters sleep mode, the fan will not stop until the printer engine has cooled down.
- Sleep mode allows the print engine to cool, so the temperature of your room and the amount of time the printer has been in sleep mode affects the warm-up time. Warm-up time can take about 60 seconds. The READY lamp blinks to indicate that the printer is warming up.
- You can change the time-out for sleep mode with the printer driver. For more information, open the Setup dialog box of your printer driver in the Windows Control Panel and choose Help or press the F1 key.

Test Page

When you hold down the READY↔SLEEP switch for about 3 seconds, the printer will print a test page. You can check the print condition or print quality with it.

SETUP DIALOG BOX

You need to install the supplied printer driver before printing documents. If you have not installed the printer driver, be sure to install it referring to the Quick Setup Guide. The installed printer driver allows you to control the printer from within the Setup dialog box.

You can open the Setup dialog box from the Windows Control Panel or your application software.

Note

Application software has Print Setup or Print under the File menu. Choose either to open the Setup dialog box of this printer driver. For information, see the user's guide for your application software.

To open the Setup dialog box from Control Panel, follow these steps:

1. Start Windows.
2. Open Control Panel in the Main group window.
3. Open Printers in the Control Panel window.
4. Make sure that your printer has been selected and set as the default printer.
5. Choose Setup to open the Setup dialog box for your printer.

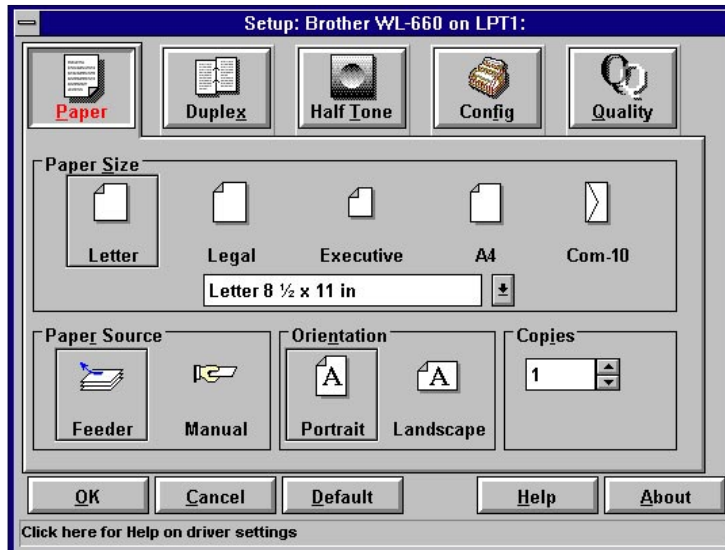

Fig. 3-3 Setup Dialog Box

The rest of this chapter briefly describes print options available in the Setup dialog box. For more information about print options, choose Help or press the F1 key while you see the options in the dialog box.

6. Click any icon button in the Setup dialog box to open the setting menu and choose Print Options.
7. Choose OK to close the dialog box and return to the Printers dialog box.
8. Choose Close to return to the Control Panel.
9. Close the Control Panel.

Your selected print options remain effective until you change them from within the Printers dialog box of the Control Panel or the Print Setup dialog box of your application software.

 **Note**

Some Windows applications have Printer Setup options that do not coincide with Control Panel settings. If you receive an error message when trying to print, please consult the User's Guide for the program you are trying to print from or contact the software manufacturers user support department.

Paper

When you click Paper in the Setup dialog box, you can:

- Choose paper size
- Choose paper tray
- Choose page orientation
- Choose the number of copies you wish to print



Fig. 3-4 Paper Options in the Setup Dialog Box

Note

- For printing envelopes, orientation should generally be set to Landscape.
- When an envelope is selected as the paper size, some applications will automatically set the paper source to Manual Feed.

Duplex

When you click Duplex in the Setup dialog box, you can:

- Choose options for duplex printing
- Set binding offset



Fig. 3-5 Duplex Options in the Setup Dialog Box

Half Tone

When you click Half Tone in the Setup dialog box, you can:

- Adjust brightness and contrast of gray scale graphics
- Choose the type of gray scale graphics

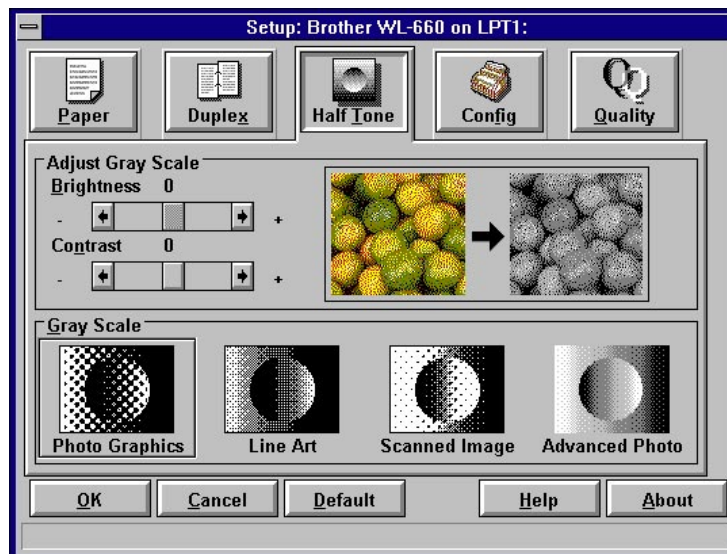

Fig. 3-6 Half Tone Options in the Setup Dialog Box

Printer Configuration

When you click Configuration in the Setup dialog box, you can:

- Perform a test print
- Choose time-out for sleep mode
- Confirm the printer memory size
- Turn error recovery operation on or off
- Turn the Printer Status on or off

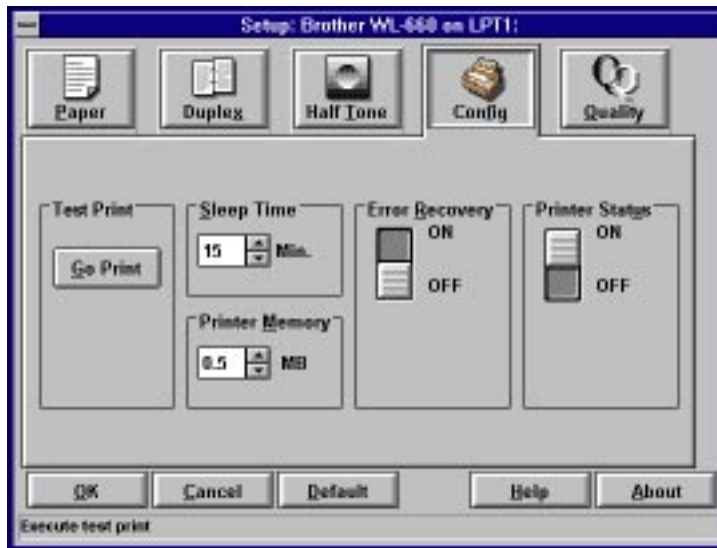

Fig. 3-7 Test Options in the Setup Dialog Box

Quality

When you click Quality in the Setup dialog box, you can:

- Choose resolution (600 dpi, 300 dpi or 150 dpi)
- Choose toner saving modes

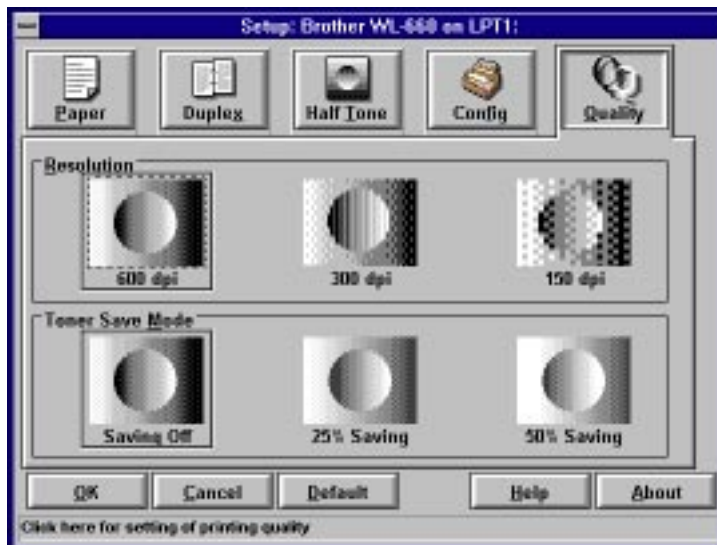

Fig. 3-8 Quality Options in the Setup Dialog Box

CHAPTER 4 OPTIONS

MEMORY BOARD

Additional memory is useful and maybe necessary if you are printing a very complex document.

The printer has 0.5 MB of memory as a standard feature. The memory can be expanded up to 4.0 MB with an optional memory board.

Two types of memory boards are available as options: 1.5 or 3.5 MB memory expansion. These options may be purchased directly from Brother or from an authorized Brother dealer.

 **Note**

The printer can recognize a maximum 4.0 MB of memory.

The memory board is installed onto the main controller board inside the printer. For more information about installation, please see the Instruction Guide that comes with the memory board.

USER'S GUIDE

CHAPTER 5 MAINTENANCE

REPLACING THE TONER CARTRIDGE

The printer includes a starter toner cartridge which is expected to yield 1,000 pages. (This may vary depending on the area where the printer is purchased.) With a new replacement toner cartridge (TN-100 or TN-100HL), the printer can print up to 3,000 pages.

When the toner cartridge is running low, the TONER LOW message appears on your computer screen.

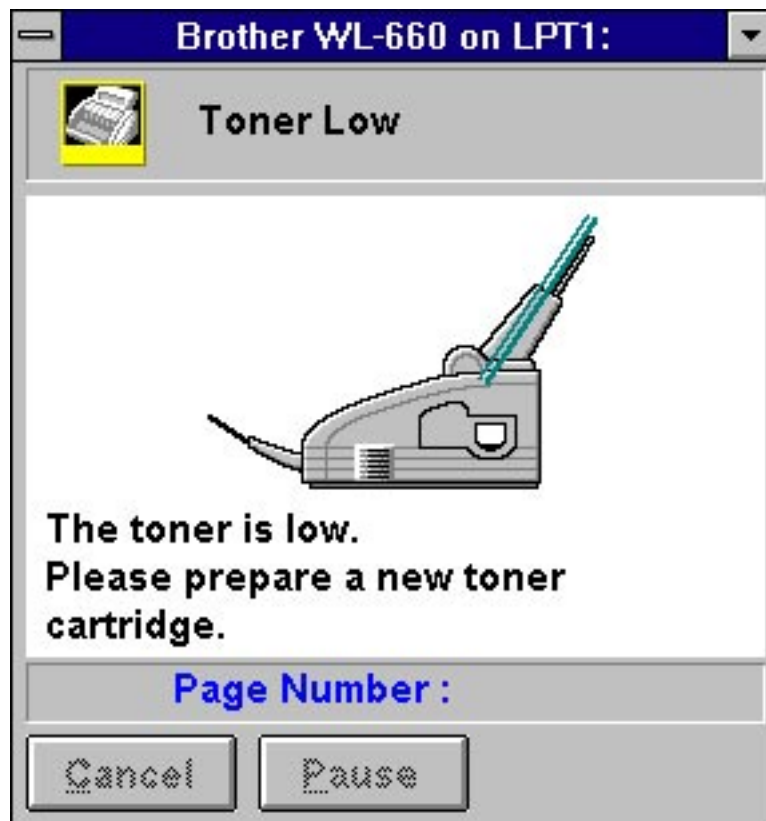

Fig. 5-1 Toner Low Indication

Note

After the first toner low indication, you can print about 100 pages. It is recommended that you always keep a new toner cartridge ready to use in case you get the toner low warning. Installing a new toner cartridge should eliminate the toner low indication.

USER'S GUIDE

When you see the TONER EMPTY message on the computer screen and the blinking ALARM lamp on the printer's control panel, you must replace the toner cartridge with a new one. **You cannot resume printing until you install a new toner cartridge.**

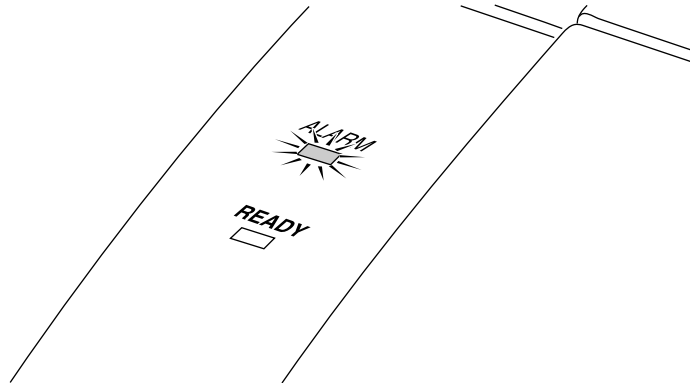

Fig. 5-2 Toner Empty Indication

Note

- Installing a new toner cartridge should eliminate the toner empty indication.
- Discard the used toner cartridge according to local regulations. If you are not sure of them, consult your local dealer.
- It is recommended that you clean the printer when you replace the toner cartridge. See “CLEANING THE PRINTER” in this chapter.

Follow these steps to replace the toner cartridge:

1. Lift the multi-purpose sheet feeder from the printer to remove it.

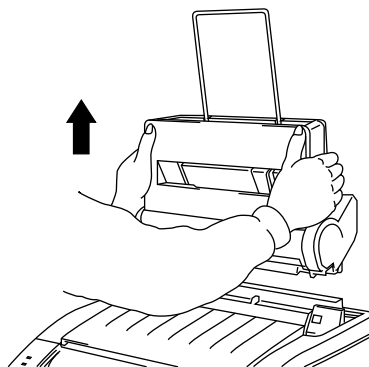

Fig. 5-3 Removing the Multi-Purpose Sheet Feeder

2. Gently push the toner cartridge shutter lever all the way to the rear of the printer.

Note

The toner cartridge cannot be removed unless the shutter is completely closed by pushing the lever fully to the rear.

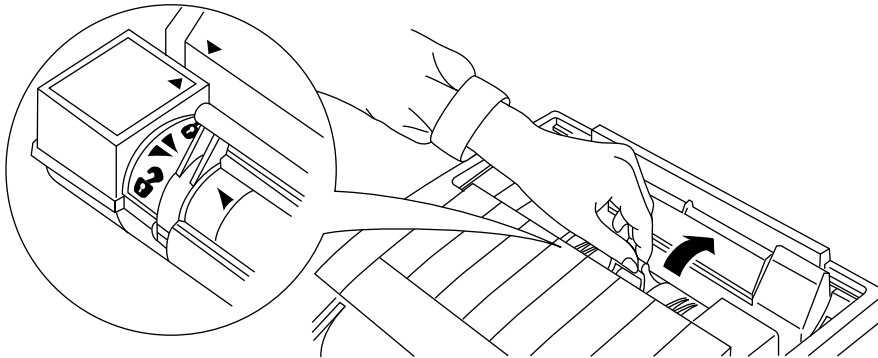

Fig. 5-4 Closing the Shutter of the Toner Cartridge

3. Remove the old toner cartridge from the printer.

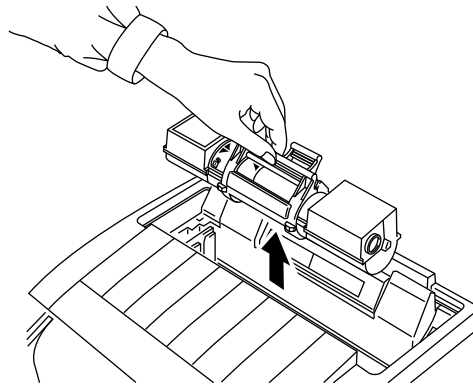

Fig. 5-5 Removing the Old Toner Cartridge

Caution

Handle the toner cartridge carefully. If toner scatters and your hands or clothes get dirty, wipe or wash it off with cold water immediately.

USER'S GUIDE

4. Unpack the new toner cartridge. Gently shake it well before installing. Then remove the protective seal.

⚠ **Caution**

- Unpack the toner cartridge immediately before installing it into the printer. If toner cartridges are left unpacked for a long period of time, the toner life is shortened.
- Do not remove the blue plastic shutter. Doing so will cause toner to spill and make the cartridge unusable.
- **You can use only a genuine Brother toner cartridge. Using another brand of toner cartridge could void your printer's warranty.**

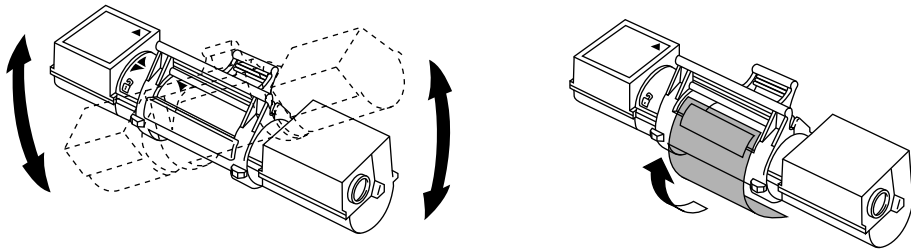

Fig. 5-6 Shaking the Toner Cartridge and Remove the Protective Parts

5. Install the new toner cartridge into the drum unit while the drum unit is inside the printer. Make sure that the ▲ marks are aligned.

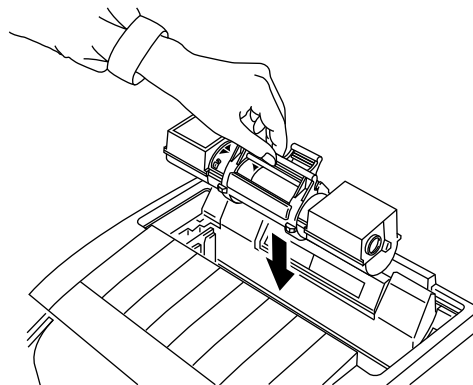

Fig. 5-7 Installing the Toner Cartridge into the Drum Unit

6. Gently pull the blue shutter lever on the toner cartridge forward until the red arrow marks are aligned.

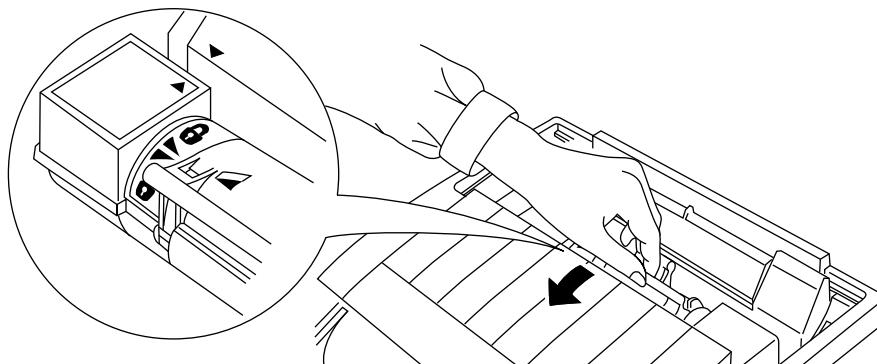

Fig. 5-8 Opening the Toner Cartridge Shutter

7. Re-install the multi-purpose sheet feeder.
See the section “MULTI-PURPOSE SHEET FEEDER” in Chapter 2.

⚠ Caution

The toner cartridge must be removed from the printer and placed in the reusable storage bag before transporting the printer. Failure to do so will void the warranty.

REPLACING THE DRUM UNIT

The printer uses a drum unit to create print images. To decide when you should replace the drum, you should check the print quality. If there has been a noticeable deterioration in the output print quality, then the drum unit should be replaced.

Note

- When removing the drum unit, handle carefully as it may contain loose toner.
- You should clean the printer when you replace the drum unit. See “CLEANING THE PRINTER” in this chapter.
- Discard the used drum unit according to local regulations. If you are not sure of them, consult your local dealer.

Follow these steps to replace the drum unit:

1. Unplug the printer.
2. Remove the multi-purpose sheet feeder. Remove the toner cartridge and keep it in a safe place. See the chapter “REPLACING THE TONER CARTRIDGE” for more information.

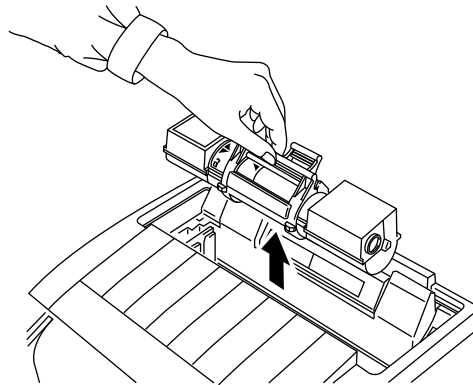

Fig. 5-9 Removing the Toner Cartridge

3. Open the top cover and drum cover of the printer.

Warning

After you have used the printer, some internal parts of the printer are extremely hot. When you open the top cover of the printer, never touch the shaded parts shown in the following diagram.

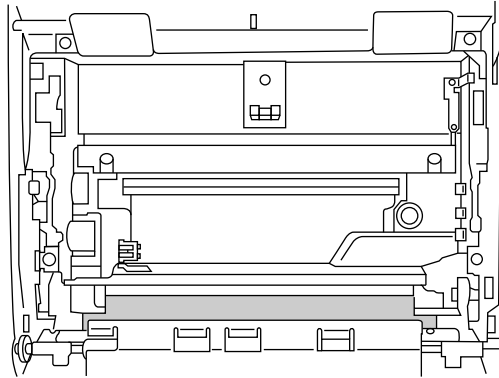

Fig. 5-10 Inside the printer

4. Remove the old drum unit by lifting it gently. Make sure that you grasp the ▲ marks.

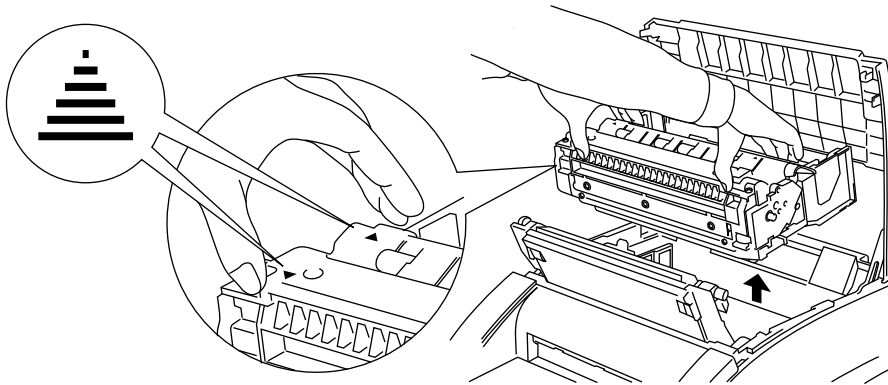

Fig. 5-11 Removing the Drum Unit

USER'S GUIDE

5. Unpack the new drum unit and gently shake it from side to side five or six times.

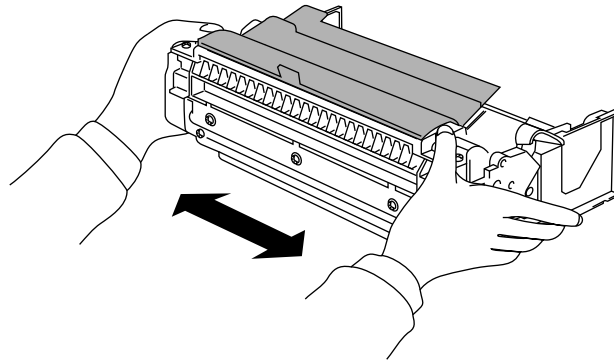

Fig. 5-12 Unpacking the Drum Unit

6. Remove the protective parts ① - ⑥ in order as shown below.

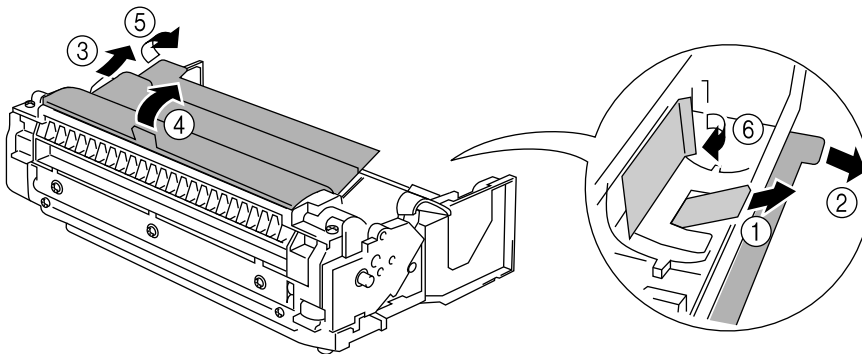

Fig. 5-13 Removing the Protective Parts

Caution

- Unpack a drum unit immediately before installing it into the printer. Exposing an unpacked drum unit to direct sunlight or room light may damage the unit.
- Be sure all protective parts are removed. Failure to remove every one can result in unacceptable print quality or may damage your printer.
- Handle the toner cartridge and the drum unit carefully as it may contain loose toner. If toner scatters and your hands or clothes get dirty, wipe or wash it off with cold water immediately.

7. Hold the drum unit flat and install it into the printer.

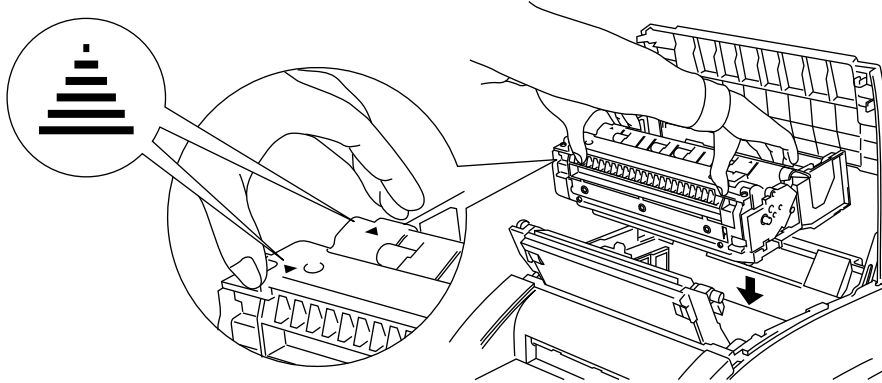

Fig. 5-14 Installing the Drum Unit

8. Close the drum cover. Press down firmly on both sides of the blue levers to ensure that it is locked securely in place, then close the top printer cover.
9. Install the toner cartridge into the drum unit once the drum unit is inside the printer. See the chapter “REPLACING THE TONER CARTRIDGE” for more information. Install the multi-purpose sheet feeder.
10. Plug in the power cord.

ADJUSTING THE PRINT DENSITY

The print density dial is located near the power cord on the back of the printer. You can use it to adjust the amount of toner applied to the paper.

When the toner cartridge and drum unit are replaced or if the operating temperature and humidity are high or low, print conditions may change causing darker or lighter printouts.

Use a screwdriver to turn the print density dial clockwise for darker printouts and counterclockwise for lighter printouts. The dial has been set to the middle position.

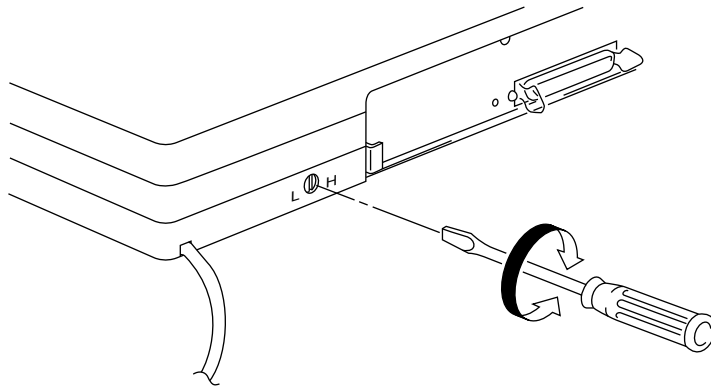

Fig. 5-15 Adjusting the Print Density Dial

CLEANING THE PRINTER

Clean the printer exterior and interior periodically. If printed pages get stained with toner, clean the printer interior and drum unit.



Warning
Before cleaning the printer, unplug the power cord.

Cleaning the Printer Exterior

Clean the printer exterior as follows:

1. Unplug the power cord.
2. Remove the paper from the multi-purpose sheet feeder.
3. Use a damp cloth for cleaning.

 **Caution**

Use water or neutral detergents for cleaning. Cleaning with volatile liquids such as thinners or benzene will damage the surface of the printer.

4. Wipe dirt and dust away from the printer exterior and feeder with a cloth.
5. Load paper into the multi-purpose sheet feeder and plug in the power cord.

Cleaning the Printer Interior and Drum Unit

Clean the printer interior and the drum unit as follows:

1. Unplug the power cord.
2. Remove the multi-purpose sheet feeder.
3. Open the top cover of the printer.
4. Open the drum cover.



Warning

After you have used the printer, some internal parts of the printer are extremely hot. When you open the top cover of the printer, never touch the shaded parts shown in the following diagram.

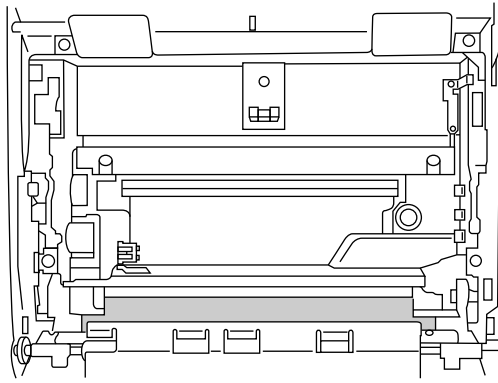

Fig. 5-16 Inside the printer

5. Use a soft cloth to remove any dirt or dust from the drum cover and inside of the printer. You may use cleaning alcohol (isopropyl) with a cotton swab to wipe the rollers (①) and pinch rollers (②) of the drum cover.

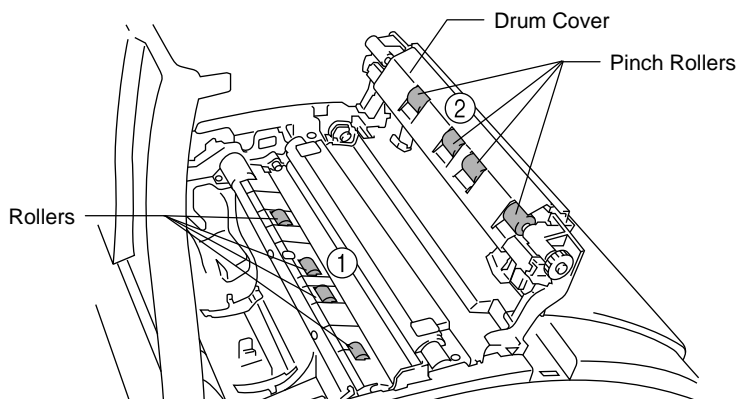

Fig. 5-17 Cleaning the Drum Cover and Rollers

⚠ Caution

Use water or neutral detergents for cleaning. Cleaning with volatile liquids such as thinners or benzene will damage the internal surfaces of the printer.

6. Take the drum unit out of the printer.
7. Wipe the following electric plates ③, ④, ⑤ with cleaning alcohol on a cotton swab. Wipe the scanner window ⑥ and the toner sensor ⑦ with a soft dry cloth.

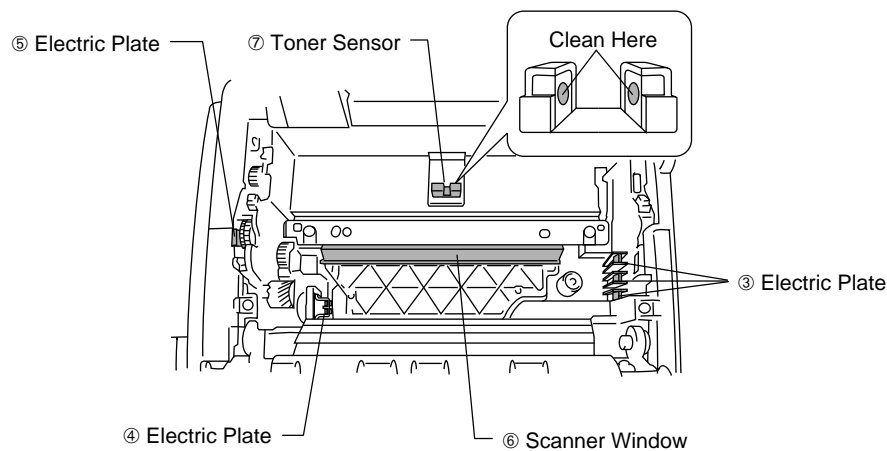

Fig. 5-18 Cleaning the Printer Interior

⚠ Caution

- Do not wipe the scanner window with cleaning alcohol (isopropyl).
- Make sure that the arrow marks on the toner cartridge are aligned with each other before turning the drum unit upside down. See the section "REPLACE THE TONER CARTRIDGE" in Chapter 5.

8. Turn the drum unit upside down carefully.

⚠ Caution

Handle the drum unit carefully as it contains toner. If toner scatters and your hands or cloths get dirty, wipe or wash it off with cold water immediately.

USER'S GUIDE

9. Clean the primary corona wire inside the drum unit by gently sliding the tab right and left several times.

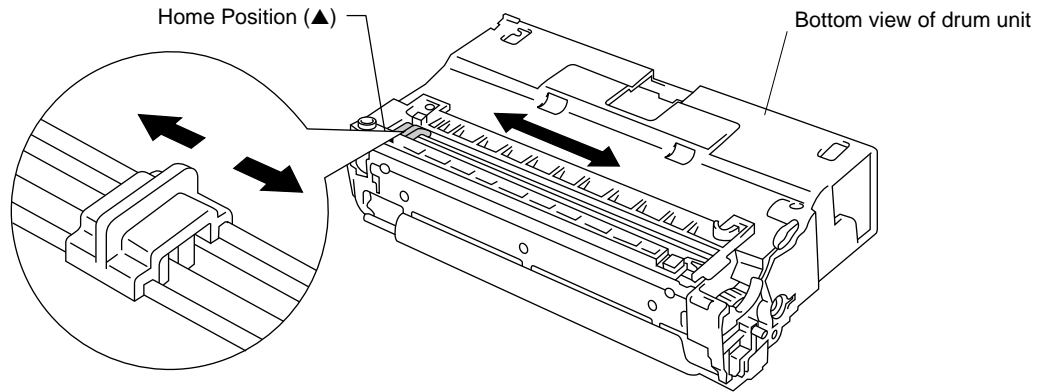

Fig. 5-19 Cleaning the Primary Corona Wire

10. When cleaning is completed, position the tab at the left end of the drum unit (▲ mark position.)

⚠ Caution

Be sure to position the tab at the home position or to the left end of the drum after cleaning.

11. Re-install the drum unit into the printer.
See the section “REPLACING THE DRUM UNIT” in Chapter 5.

12. Close the drum cover and top cover.

⚠ Caution

Be sure to close the drum cover securely by pressing down firmly on both sides next to the blue tabs.

13. Install the multi-purpose sheet feeder.
See the section “MULTI-PURPOSE SHEET FEEDER” in Chapter 2.
14. Plug in the power cord.

RE-PACKING THE PRINTER

⚠ Caution

Whenever you transport the printer, use the packing materials which are provided with your printer. Also, follow the steps below to re-pack the printer to avoid damage which could invalidate your warranty.

1. Unplug the printer from the AC outlet.
2. Remove the multi-purpose sheet feeder and wrap it in the plastic bag.
3. Open the top cover and the drum cover.
4. Remove the drum unit assembly, referring to the previous section.

✍ Note

Remove the drum unit assembly with the toner cartridge still inside.

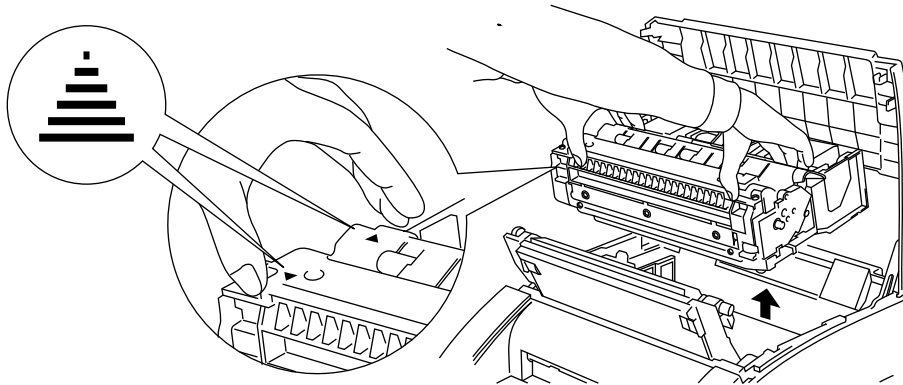

Fig. 5-20 Removing the Drum Unit Assembly

USER'S GUIDE

5. Place the drum unit assembly in the plastic bag. Hold the plastic bag with your hand under the drum unit assembly and wrap it in the corrugated cardboard.

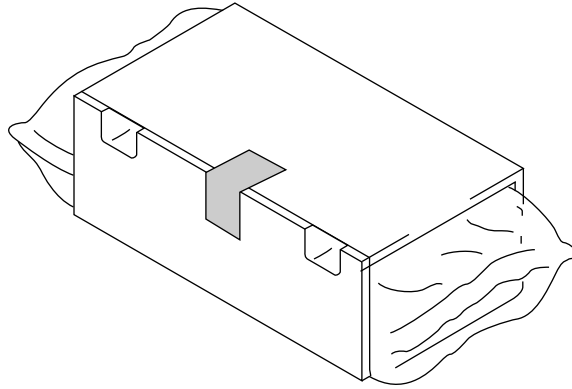

Fig. 5-21 Placing the Drum in the Plastic Bag and Wrapping it in the Corrugated Cardboard

6. Close the top cover, the drum cover, the paper support wire and the output tray.
7. Wrap the printer in the plastic bag included in the box, then place it in the carton inside the Styrofoam packing.
8. Place the multi-purpose sheet feeder, documents, and drum unit assembly in the carton as shown below.
9. Close the carton and tape it securely shut.

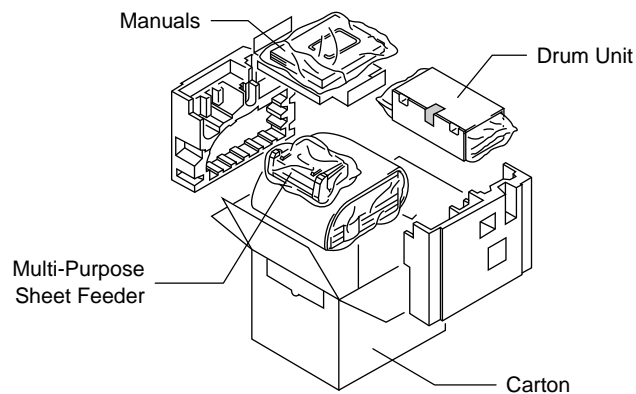

Fig. 5-22 Re-packing the Printer

CHAPTER 6 TROUBLESHOOTING

ALARM INDICATIONS AT A GLANCE

Operator Calls

If an error occurs, the printer indicates an “operator call” by blinking the ALARM lamp. The status monitor appears on your computer screen to indicate the error.

The printer can recover from most errors if you take the proper action following the displayed instructions.

Operator Call	Action
Cover Open	Close the top cover of the printer or press firmly on the multi-purpose sheet feeder to make sure it is properly installed.
Mis Feed	Reinstall the paper.
Paper Empty	Load paper into the printer referring to Chapter 2.
Paper Jam	Clear the paper jam referring to the next section “PAPER JAMS” and press the READY↔SLEEP switch if the printer does not automatically resume printing. Do not simply pull the paper out before referring to the next section.
Bi-Directional Error	Check that the connection between your computer and printer is secure and correct, and check the interface cable, to ensure it is screwed into the back of the computer and secured by the clips on the printer's port.
Print Overrun	<ul style="list-style-type: none"> • Turn error recovery operation on in the Setup dialog box. • Reduce the complexity of your document or reduce the print resolution. • Expand the printer memory by installing one of the optional memory boards.
Toner Empty	Replace the toner cartridge with a new one.

Note

If the printer does not operate as you expect it to, it is recommended that you unplug the printer, wait a few seconds and then plug it in again. If you still have problems, consult your dealer or our authorized service representative.

Service Calls

If an unrecoverable error occurs, the printer indicates the need for a service call by lighting both the ALARM and READY lamps and the status monitor appears on your computer screen to indicate the error.

Service Call	Error Status
FUSER MALF	The fixing assembly is out of order.
LASER BD MALF	The BD signals of the laser scanner cannot be detected.
SCANNER MALF	The laser scanner is out of order.
D-RAM ERROR	The D-RAM is out of order.
NV-RAM ERROR	The NV-RAM is out of order.

If you see any of the above service call indicators, reset the printer by unplugging it and plugging in the power cord again.

If you cannot clear the error and see the same service call indicator after resetting the printer, consult your dealer or contact your nearest Brother Authorized Service Center for repair.

 **Note**

Check the top cover, the multi-purpose sheet feeder and the main controller board to verify that they are firmly installed.

PAPER JAMS

If a paper jam occurs, the dialog box appears on your computer screen and instructs you to take appropriate action. After you remove the jammed paper, the error indicator disappears and the printer should automatically recover from the error.

Before you can clear a paper jam error, you need to find the location of the paper jam. Locate the position referring to the following figure.

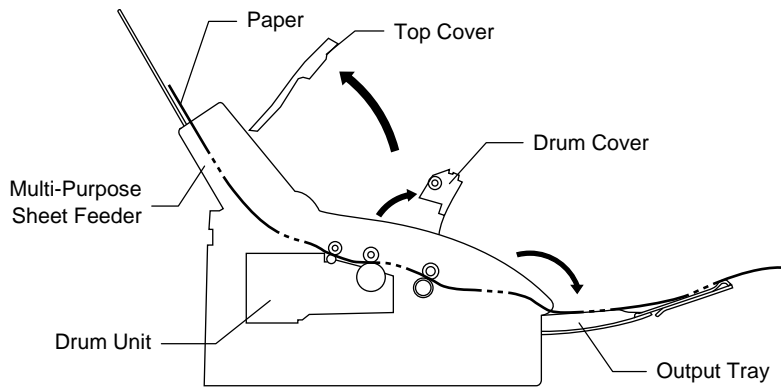

Fig. 6-1 Locating Paper Jam Position

After locating the position, clear the jammed paper, referring to the following descriptions. Once the jammed paper is removed completely, the printer may resume printing. If the printer does not resume printing, press the READY↔SLEEP switch or check the Print Manager in Windows to see if the print job registers as stalled. If the print job is stalled in Print Manager, click on RESUME to continue printing.

❑ Paper Jam at the Paper Output Tray

⚠ **Caution**

Do not pull the jammed paper from the output tray. Be sure to open the drum cover inside the printer to remove the jam or the jammed paper may tear and pieces of paper may remain inside the printer. See the next page for instructions on how to remove the jammed paper.

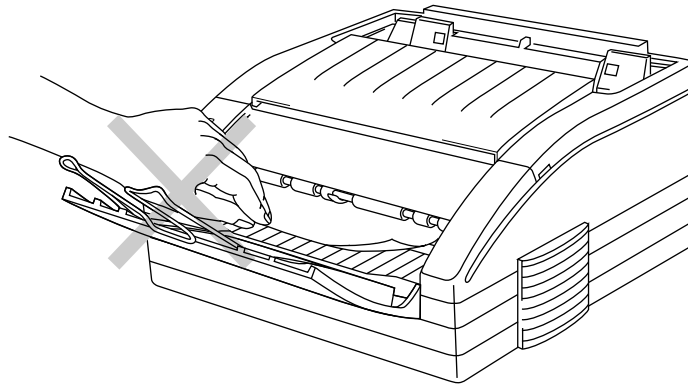

Fig. 6-2 Paper Jam at the Paper Output Tray

❑ Paper Jam in the Multi-Purpose Sheet Feeder

If a paper jam has occurred inside the multi-purpose sheet feeder, open the multi-purpose sheet feeder to pull the jammed paper upward out of the feeder; then close the multi-purpose sheet feeder. Also, open the top cover and check to make sure that a torn piece does not remain inside the printer. Refer to the next section for assistance.

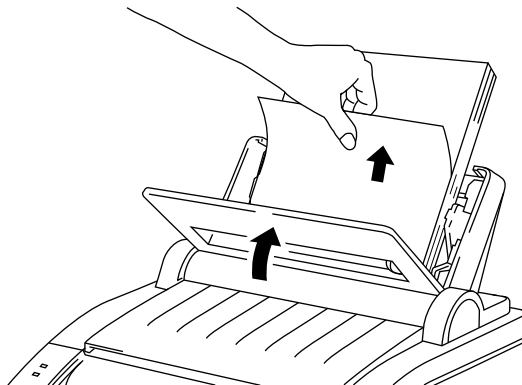

Fig. 6-3 Paper Jam in the Feeder

If the paper cannot be pulled up, see the next section “Paper Jam Under the Drum Cover.”

❑ Paper Jam under the Drum Cover

If a paper jam has occurred under the drum cover, remove the multi-purpose sheet feeder, open the top cover and the drum cover. Then pull the jammed paper upwards and out of the printer. Close the covers.

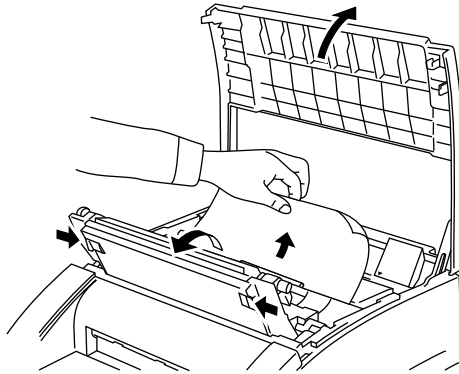

Fig. 6-4 Paper Jam under the Drum Cover

❑ Paper Jam Inside the Printer

If a paper jam has occurred under the drum unit, you must remove the multi-purpose sheet feeder, open the top cover and the drum cover, remove the drum unit, and pull the jammed paper out of the printer. Then re-install the drum unit and close the covers.

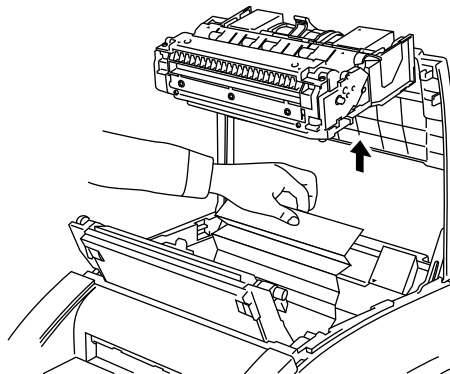

Fig. 6-5 Paper Jam Inside the Printer



Warning

After you have used the printer, some internal parts of the printer are extremely hot. When you open the top cover of the printer, never touch the shaded parts shown in the following diagram.

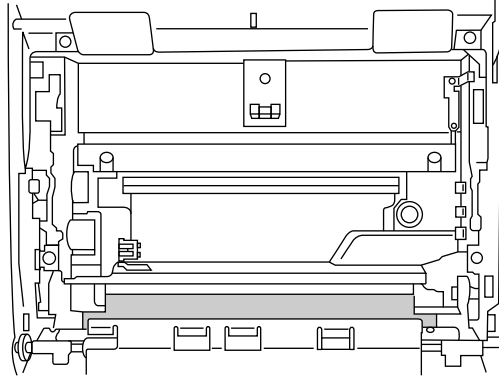

Fig. 6-6 Inside the Printer

Q & A

This section contains questions and answers for using your printer. If you have encountered a problem, find the question relating to your problem and take the steps recommended to correct the problem.

Setting up the Printer Hardware and Software

Question	Recommendation
The printer does not work. All lamps are off.	The printer may be in sleep mode. Press the READY↔SLEEP switch to wake up the printer. Check to see if the printer is plugged into a live power source.
The printer does not print.	Check the following: <ul style="list-style-type: none"> • All of the protective parts have been removed. • The toner cartridge and drum unit are installed properly. • The interface cable is securely connected between the printer and computer. • Check to see if the ALARM lamp is blinking. Refer to Operator Call section of this manual if it is. • Check your computer screen for any error message.
I cannot print from my Windows application software.	Make sure the supplied printer driver is installed and selected with your application software. Please refer to the Quick Setup Guide for instructions.
The cursor does not move with mouse movement, or a keyboard error occurs.	Turn off the PC, press the READY↔SLEEP switch to put the printer into sleep mode, and then turn on the PC power switch.
The status monitor does not appear on the computer screen.	<ul style="list-style-type: none"> • Make sure you are not using any printer buffer switches or switch boxes. Connect the printer directly to the PC. • The cable may be disconnected or defective. Replace it or try a different cable.
The printer is still in sleep mode when I send a print job from my software.	<ul style="list-style-type: none"> • Make sure you are not using any printer buffer switches or switch boxes. Connect the printer directly to the PC. • The cable may be disconnected or defective. Replace it or try a different cable.

USER'S GUIDE

Paper Handling

Questions	Recommendations
The printer does not load paper.	<ul style="list-style-type: none"> • Check to see if the “Paper Empty” message appears on your computer screen or the ALARM lamp is blinking on the printer control panel. If so, the multi-purpose sheet feeder may be out of paper or not properly installed. If it is empty, load a new stack of paper into the feeder. • If there is paper in the multi-purpose sheet feeder, make sure it is straight. If the paper is curled, you should straighten it before printing. Sometimes it is helpful to remove the paper, turn the stack over and replace it in the paper tray. • Reduce the stack of paper in the multi-purpose sheet feeder, then try again.
The printer does not load paper from the manual feed slot.	Re-insert the paper firmly, one sheet at a time.
How can I load envelopes?	You can load envelopes from either the multi-purpose sheet feeder or the manual feed slot. Your application software must be set up correctly to print on the envelope size you are using. This is usually done in the page setup or document setup menu of your software. Refer to your application user's guide for instructions.
What kind of paper can I use?	You can use plain paper, envelopes, transparencies, labels, and organizer paper. For information on loading paper, see “Paper Handling” in Chapter 2.
How can I clear paper jams?	See “PAPER JAMS” in this chapter.

Printing

Questions	Recommendations
Sometimes I get a Print Overrun error when printing certain documents from Windows.	<ul style="list-style-type: none"> • Turn error recovery operation on in the Setup dialog box and try again. • Reduce the print resolution or reduce the complexity of your document and try again. • Expand the printer memory by installing one of the optional memory boards.

<p>The printer prints unexpectedly or it prints garbage.</p>	<p>Make sure your Windows application software is correctly set up to use this printer. Check your Windows printer driver settings or printer settings in your application software. Be sure there are no stalled jobs in Print Manager.</p>
<p>My headers or footers appear when I view my document on screen but do not show up when I print them.</p>	<p>Most laser printers have a restricted area that cannot be printed on. Usually the first two lines and last two lines of the paper cannot be printed on. Adjust the top and bottom margins in your document to allow for this. The non-printable area for this printer is approximately 4 mm or 0.16 inches from each edge of the paper.</p>

Print Quality

<p>Questions</p>	<p>Recommendations</p>
<p>Printouts are too dark or light.</p>	<p>Turn the print density dial counterclockwise to make the image lighter and clockwise for darker images. It has been factory set to the middle position. See “ADJUSTING THE PRINT DENSITY” in Chapter 5.</p>
<p>Printed pages contain white stripes.</p>	<p>You may clear the problem by wiping the scanner windows with a soft cloth. (See “Cleaning the printer interior and Drum unit.”) If the same problem occurs after cleaning, try shaking the drum unit from side to side with the toner cartridge inside of it, or replace the drum unit with a new one.</p>



Fig. 6-7 White Stripes or Faint Images

USER'S GUIDE

<p>Printed pages have white spots in black text and graphics area.</p>	<ul style="list-style-type: none"> • Make sure that you use paper that meets the specifications. A rough surface or thick media can cause the problem. • If you still have the same problem, replace the drum unit with a new one.
--	--

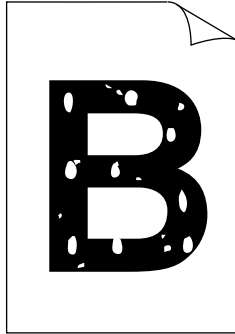

Fig. 6-8 White Spots

<p>Printed pages are stained with toner or have vertical stripes.</p>	<ul style="list-style-type: none"> • Clean the printer interior and the primary corona wire of the toner cartridge. See “Cleaning the Printer Interior and Drum Unit” in Chapter 5. • Make sure that the tab of the corona wire is at the home position. • Remove the drum unit with the toner cartridge installed. Hold it horizontally with both hands and tap it firmly against a flat surface 3 or 4 times. <p>If the same print problem occurs after cleaning, replace the drum unit with a new one.</p>
---	--

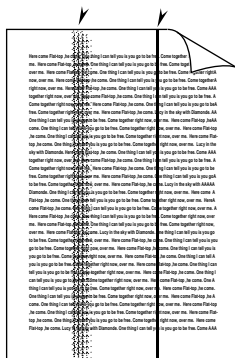

Fig. 6-9 Dark Stripes or Toner Stains

<p>The whole page is printed in black.</p>	<p>Wipe the contact plates with cleaning alcohol. See “Cleaning the Printer Interior and Drum Unit” in Chapter 5. Never use heat-sensitive paper as it will cause this problem.</p> <p>If the same problem occurs after cleaning, replace the drum unit with a new one.</p>
--	---

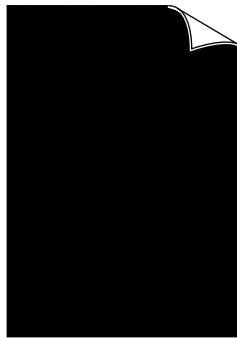

Fig. 6-10 Black Page

<p>Toner scatters and stains the printed page.</p>	<p>If toner scatters over the whole printing surface, adjust the print density dial inside the printer clockwise. See “ADJUSTING THE PRINT DENSITY” in Chapter 5.</p> <p>Clean the printer interior. See “Cleaning the Printer Interior and Drum Unit” in Chapter 5.</p> <p>Make sure that you use paper that meets specifications.</p> <p>If you still have the same problem, replace the drum unit with a new one.</p>
--	--

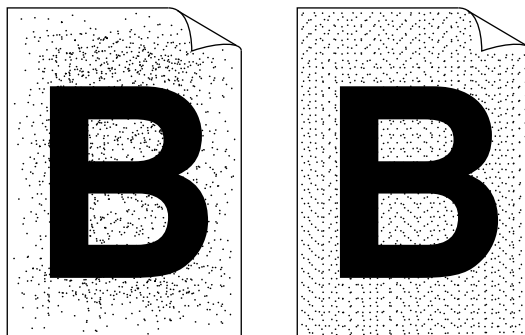

Fig. 6-11 Scattering Toner

USER'S GUIDE

<p>Nothing is printed on the page.</p>	<ul style="list-style-type: none">• Make sure that the toner cartridge is not empty and that the sealing tape has been removed from the toner cartridge.• Wipe the contact plates with cleaning alcohol. See “Cleaning the printer interior and Drum Unit” in Chapter 5.
--	---



Fig. 6-12 White Page

<p>Printed pages are stained at fixed intervals.</p>	<p>The problem may disappear. Try printing multiple pages to clear this problem if the printer has not been used for a long time. If the surface of the drum has been scratched or exposed to light, replace the Drum Unit with a new one.</p>
--	--

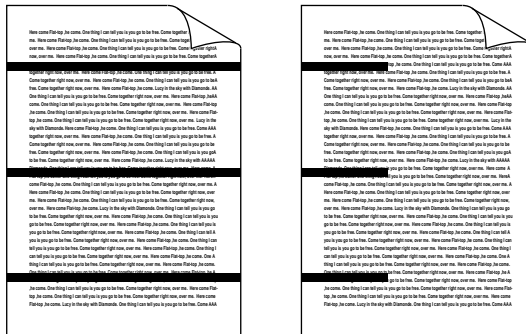

Fig. 6-13 Stained at Fixed Interval

Certain environmental conditions such as humidity, high temperatures, etc. may cause the following situation to occur.

<p>Printed pages are blurred at the center or either edge.</p>	<ul style="list-style-type: none">• Make sure that the printer is placed on a flat, horizontal surface.• Remove the drum unit with the toner cartridge installed. Hold the unit up 20 mm at a 45 degree with both hands. Tap it firmly against a flat surface a few times and then shake it sideways gently 5 or 6 times. Re-install the drum/toner unit and try printing again. If the print quality is not acceptable, please contact Brother customer service or your local authorized service center for further assistance.• You may clear the problem by wiping the scanner windows with a soft cloth. (See "Cleaning the printer interior and Drum unit.") If the same problem occurs after cleaning, replace the drum unit with a new one.
--	--

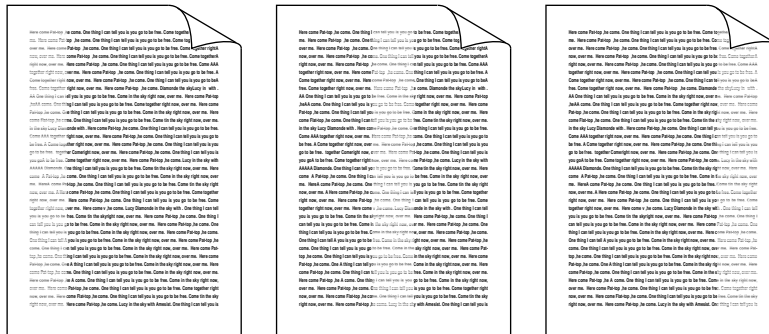

Fig. 6-14 Blurred Page

USER'S GUIDE

APPENDICES

PRINTER SPECIFICATIONS

Printing

Print Method	Electrophotography by semiconductor laser beam scanning
Laser	Wavelength: 780 nm Output: 5 mW max
Resolution	600 dots per inch with APT (Advanced Photoscale Technology)
Print Quality	Normal printing mode Economy printing mode (up to 50% toner saving)
Print Speed	6 pages per minute (when loading A4 or letter-size paper from the multi-purpose sheet feeder)
Warm-Up	Approximately 1 minute at 23°C (73.4°F)
First Print	20 seconds (when loading A4 or letter-size paper from the multi-purpose sheet feeder)
Print Media	Toner in a cartridge Life 3,000 pages per cartridge using a TN-100 or TN-100HL - Replacement toner cartridge 1,000 pages per cartridge when using the starter toner cartridge (printing on A4 or letter size paper at 5% print coverage).

Functions

Printer Driver	Windows 3.1/3.11 driver, supporting bi-directional capability TrueType™ compatible fonts for Microsoft Windows®
Interface	Bi-directional parallel
Memory	0.5 MB (subject to the printer model) Expandable up to 4.0 MB with the optional memory board
Control Panel	1 switch and 2 lamps
Diagnostics	Self-diagnostic program

USER'S GUIDE

Electrical and Mechanical

Power Source	U.S.A. and Canada:	AC 110 to 120 V, 60 Hz
	Europe and Australia:	AC 220 to 240 V, 50 Hz
Power Consumption	Printing:	480 W or less
	Stand-by:	55 W or less
	Sleep:	8 W or less
Noise	Printing:	50 dB A or less
	Stand-by:	41 dB A or less
Temperature	Operating:	10 to 32.5°C (59 to 90.5°F)
	Storage:	0 to 40°C (38 to 104°F)
Humidity	Operating:	20 to 80% (without condensation)
	Storage:	20 to 80% (without condensation)
Dimensions (W x H x D)	364.9 x 182.5 x 362.8 mm (14.4 x 7.2 x 14.3 inches) (when the output tray is closed and the Multi-purpose sheet feeder is removed.)	
Weight	Approx. 7.5 kg (16.6 lb.)	

PARALLEL INTERFACE SPECIFICATION

Interface Connector Printer Side: Amphenol 57RE-4036-7308 or equivalent
A shielded cable should be used.

Pin Assignment

Pin No.	Signal	Direction	Pin No.	Signal	Direction
1	<u>DATA STROBE</u>	Input	19	0V (S.G.)	–
2	DATA 1	Input	20	0V (S.G.)	–
3	DATA 2	Input	21	0V (S.G.)	–
4	DATA 3	Input	22	0V (S.G.)	–
5	DATA 4	Input	23	0V (S.G.)	–
6	DATA 5	Input	24	0V (S.G.)	–
7	DATA 6	Input	25	0V (S.G.)	–
8	DATA 7	Input	26	0V (S.G.)	–
9	DATA 8	Input	27	0V (S.G.)	–
10	<u>ACKNLG</u>	Output	28	0V (S.G.)	–
11	BUSY	Output	29	0V (S.G.)	–
12	PE	Output	30	0V (S.G.)	–
13	SLCT	Output	31	<u>INPUT PRIME</u>	Input
14	<u>AUTO FEED</u>	Input	32	<u>FAULT</u>	Output
15	N.C.	–	33	N.C.	–
16	0V (S.G.)	–	34	N.C.	–
17	0V (S.G.)	–	35	N.C.	–
18	+5V	–	36	<u>SLCT IN</u>	Input

Note

To use bi-directional communication, an interface cable which has the pin connection above should be used.

USER'S GUIDE

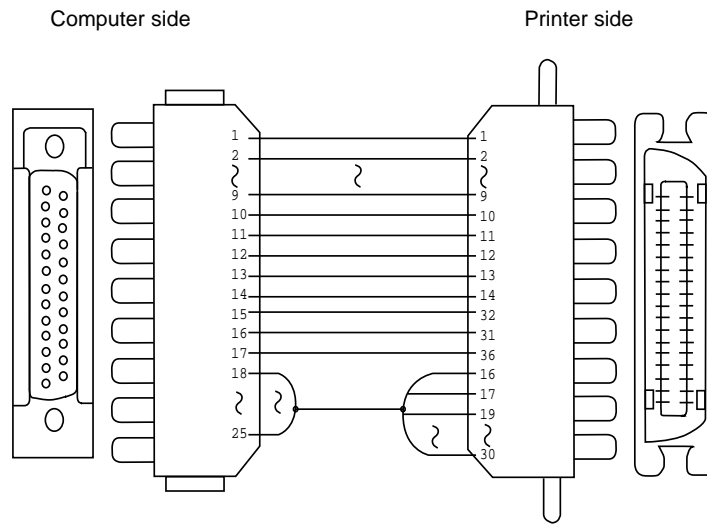

Fig. A-1 Parallel interface cable

INDEX**A**

additional memory 4-1
Advanced Photoscale Technology (APT)
1-4
ALARM lamp 3-1
Auto Resolution Reduction 1-4

B

bi-directional communication 1-3,
Appendix-3
bi-directional error 6-1

C

cleaning 5-11–14
control panel 3-1–3
cover open 6-1

D

density 5-10
drum unit 5-6–9
duplex 2-7

E

economy printing mode 1-4
envelopes 2-1–2, 2-5
environment 1-5
error 3-1, 6-1–3, 6-7–8
error recover 3-8

F

factory set 3-3
features 1-3–4
feeder 2-1, 2-4–8
font 1-3
front view 1-2

I

interface 1-3

L

label 2-1, 2-8
lamps 3-1
loading paper 2-5–6

M

manual duplexing 2-7
manual feed 2-8
memory (Option) 4-1
mis feed 6-1
multi-purpose sheet feeder 1-4, 2-4–7

O

operator calls 6-1
option 1-3, 4-1
organizer sheet 2-1
output tray 2-9
overview 1-2

P

packing the printer 5-15–16
paper 2-1
paper empty 2-6, 6-1
paper guide 2-6, 2-8
paper handling 1-4, 2-1–9
paper jam 6-1, 6-3–6
paper source 2-4
paper specifications 2-1
paper support wire 2-9
parallel interface 1-3, Appendix-3–4
power 1-5
power control 3-3
power supply 1-5

USER'S GUIDE

power switch 3-2, 3-3
printable area 2-3
print density 5-10
printer driver 1-3, 1-4
printing speed 1-3
print overrun 6-1
print quality 6-9-13

R

READY lamp 3-1
READY↔SLEEP switch 3-2-3
rear view 1-2
resolution 1-3, 1-4

S

service calls 6-2
sleep mode 1-4, 3-2-3
switch 3-2-3

T

test page 3-3
toner cartridge 1-4, 5-1-5
toner empty 5-2, 6-1
toner low 5-1
transparency 2-1, 2-8
two side printing 2-7

W

warm-up 3-3

(For USA & CANADA Only)

For technical and operational assistance, please call:

In USA	1-800-276-7746	(outside California)
	714-859-9700 Ext. 329	(within California)
In Canada	1-800-361-6466	

If you have comments or suggestions, please write us at:

In USA	Printer Customer Support Brother International Corporation 15 Musick Irvine, CA 92718
In Canada	Brother International Corporation, Ltd. 1, Rue Hôtel De Ville Dollard-des-Ormeaux P.Q. Canada H9B3H6

BBS

For downloading drivers from our Bulletin Board Service, call 1-714-859-2610. Please log on to our BBS with your first name, last name and a four digit number for your password. Our BBS supports modem speeds up to 14,400, 8 bits no parity, 1 stop bit.

DEALERS/SERVICE CENTERS

For the name of an authorized dealer or service center, call 1-800-284-4357.

brother[®]