

SAMSUNG

Digital Video Camcorder

SC-D351/D352/D353/D354/D355

<i>Features</i>	<i>2</i>
<i>Notes and Safety Instructions</i>	<i>3</i>
<i>Getting to Know Your Camcorder</i>	<i>4</i>
<i>Playback</i>	<i>7</i>
<i>Basic Recording</i>	<i>8</i>
<i>Maintenance</i>	<i>8</i>
<i>Troubleshooting</i>	<i>9</i>

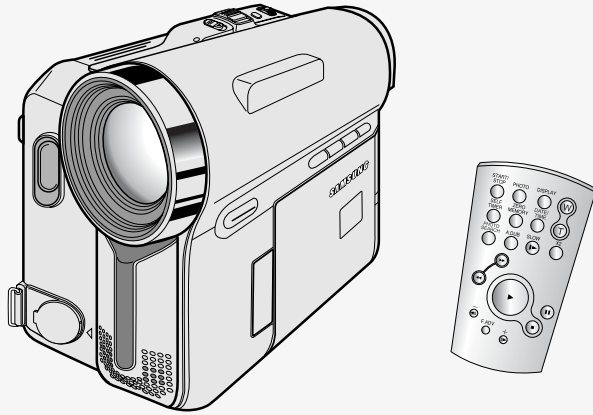

Multi OSD Language

You can select the desired OSD language among English, French, Spanish, German, Italian, Portuguese, Polish and Dutch.

Digital Data Transfer Function with IEEE1394

By incorporating the IEEE 1394 (i.LINK™: i.LINK is a serial data transfer protocol and interconnectivity system, used to transmit DV data) high speed data transport port, both moving and still images can be transferred to a PC, making it possible to produce or edit various images.

USB Interface for Digital Image Data Transfer (SC-D352/D353/D354/D355 only)

You can transfer images to a PC using the USB interface without an add-on card.

PHOTO

The photo function lets you capture an object as a still along with sound, while in camera mode.

900x Digital Zoom

Allows you to magnify an image up to 900 times its original size.

Color TFT LCD

A high-resolution color TFT LCD gives you clean, sharp images as well as the ability to review your recordings immediately.

Digital Image Stabilizer (DIS)

The DIS compensates for any handshake, reducing unstable images particularly at high magnification.

Various Digital Effects

The digital effects allows you to give your films a special look by adding various special effects.

Back Light Compensation (BLC)

The BLC function compensates for the bright background behind a subject you're recording.

Program AE

The program AE enables you to alter the shutter speed and aperture to suit the type of scene/action to be filmed.

NITE PIX (SC-D352/D354/D355 only)

The NITE PIX function enables you to record a subject in a dark place.

Digital Still Camera Function (SC-D353/D354/D355 only)

- Using Memory card, you can easily record and playback standard still images.
- You can transfer standard still images on the Memory card to your PC using the USB interface.

MPEG Recording (SC-D353/D354/D355 only)

MPEG recording makes it possible to record video onto a Memory card.

Multi Memory Card Slot (SC-D355 only)

Multi Memory card slot is able to use Memory stick, MMC and SD.

Notices regarding Copyright

Television programs, video tapes, DVD titles, films, and other program materials may be copyrighted.

Unauthorized copying of copyrighted material may be against the law.

All the trade names and registered trademarks mentioned in this manual or other documentation provided with your Samsung product are trademarks or registered trademarks of their respective holders.

Notes regarding Moisture Condensation

1. A sudden rise in atmospheric temperature may cause condensation to form inside the Camcorder.

for example:

- When you move the Camcorder from a cold location to a warm location (e.g. from outside to inside during winter.)
 - When you move the Camcorder from a cool location to a hot location (e.g. from inside to outside during the summer.)
2. If the  (DEW) protection feature is activated, leave the Camcorder for at least two hours in a dry, warm room with the cassette compartment opened and the Battery pack removed.

Notes regarding Camcorder

1. Do not leave the Camcorder exposed to high temperatures (above 60°C or 140°F). For example, in a parked car in the sun or exposed to direct sunlight.
2. Do not let the Camcorder get wet. Keep the Camcorder away from rain, sea water, and any other form of moisture. If the Camcorder gets wet, it may get damaged. Sometimes a malfunction due to exposure to liquids cannot be repaired.

Notes regarding the Battery Pack

- Use only an approved Battery pack to replace a Battery pack.
- Make sure that the Battery pack is fully charged before starting to record.
- To preserve battery power, keep your Camcorder turned off when you are not operating it.
- If your Camcorder is in camera mode, and it is left in STBY mode without being operated for more than 5 minutes with a tape inserted, it will automatically turn itself off to protect against unnecessary battery discharge.
- Make sure that the Battery pack is fitted firmly into place. Do not drop the Battery pack. Dropping the Battery pack may damage it.
- A brand new Battery pack is not charged. Before using the Battery pack, you need to charge it completely.
- Fully discharging a Lithium-Ion battery damages the internal cells. The Battery pack may be prone to leakage when fully discharged.

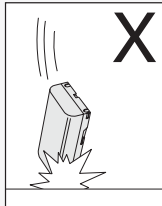

Notes regarding the battery pack

When the battery reaches the end of its life, please contact your local dealer. The batteries have to be dealt with as chemical waste.

Notes regarding the Video Head Cleaning

- To ensure normal recording and a clear picture, clean the video heads regularly. If a square block-shape distorts playback, or only a blue screen is displayed, the video heads may be dirty. If this happens, clean the video heads with a dry type cleaning cassette.
- Do not use a wet-type cleaning cassette. It may damage the video heads.

Note regarding the Lens

Do not film with the camera lens pointing directly at the sun. Direct sunlight can damage the CCD (Charge Coupled Device).

Notes regarding electronic Viewfinder

1. Do not position the Camcorder such that the Viewfinder is pointing towards the sun. Direct sunlight can damage the inside of the Viewfinder. Be careful when placing the Camcorder under sunlight or near a window exposed to sunlight.
2. Do not pick up the Camcorder by holding the Viewfinder.
3. Applying excessive force to the Viewfinder may damage it.

Notes regarding 'Record' or 'Playback' Using the LCD Screen

1. The LCD screen has been manufactured using high precision technology. However, there may be tiny dots (red, blue or green in color) that appear on the LCD screen. These dots are normal and do not affect the recorded picture in any way.
2. When you use the LCD screen under direct sunlight or outdoors, it may be difficult to see the picture clearly. If this occurs, we recommend using the Viewfinder.
3. Direct sunlight can damage the LCD screen.

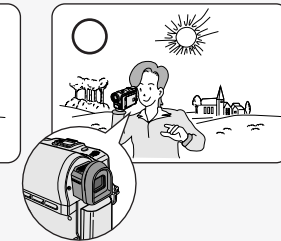

Notes regarding the Hand Strap

- To ensure a steady picture while filming, check that the hand strap is properly adjusted.
- Do not force your hand into the hand strap as you could damage it.

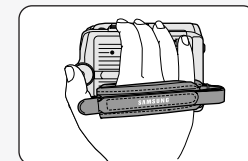

Front & Left View

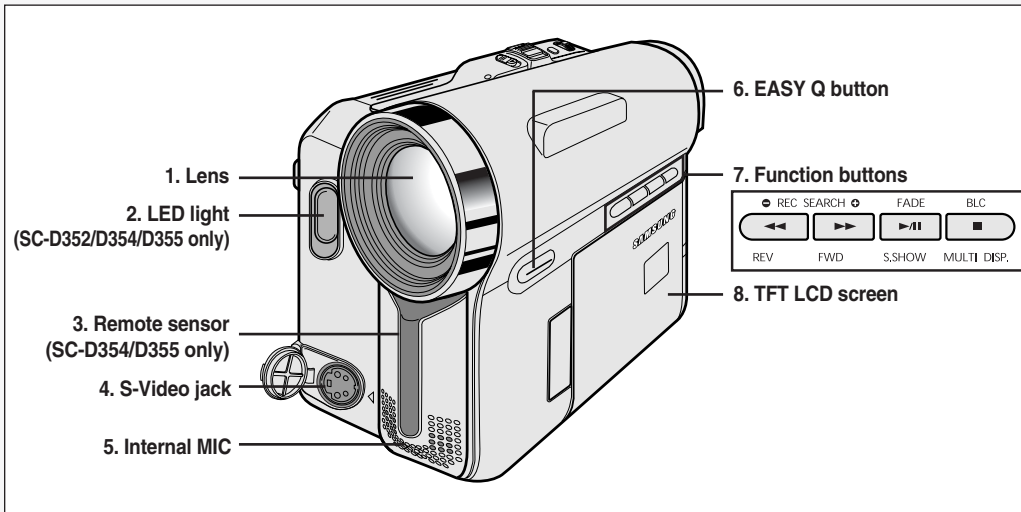

1. Lens
2. LED light (SC-D352/D354/D355 only)
3. Remote sensor (SC-D354/D355 only)
4. S-Video jack
5. Internal MIC
6. EASY Q button
7. Function buttons

PLAYER	CAMERA	M.Player (SC-D353/D354/D355 only)
-	EASY Q	-
◀◀ : REW	REC SEARCH -	REV
▶▶ : FF	REC SEARCH +	FWD
▶/ : PLAY/STILL	FADE	S.SHOW(SLIDE SHOW)
■ : STOP	BLC	MULTI DISP.

8. TFT LCD screen

Accessories Supplied with Camcorder

Make sure that the following basic accessories are supplied with your digital video camera.

1. Lithium Ion Battery Pack 	2. AC Power Adapter (AA-E8 TYPE) 	3. AC cord 	4. Audio/Video Cable
5. Instruction Book 	6. Lithium Battery (CR2025) 	7. Remote Control 	8. USB Cable
9. Software CD 	10. Lens Cover 	11. Lens Cover Strap 	
12. S-Video Cable 	13. Memory Stick 		

Basic Accessories

1. Lithium Ion Battery Pack
2. AC Power Adapter (AA-E8 TYPE)
3. AC Cord
4. Audio/Video Cable
5. Instruction Book
6. Lithium Battery for Remote Control (SC-D354/D355 only) or Clock. (TYPE: CR2025)
7. Remote Control (SC-D354/D355 only)
8. USB Cable (SC-D352/D353/D354/D355 only)
9. Software CD (SC-D352/D353/D354/D355 only)
10. Lens Cover
11. Lens Cover Strap

Basic Accessories

12. S-Video Cable
13. Memory Stick (SC-D353/D354/D355 only)

Left Side View

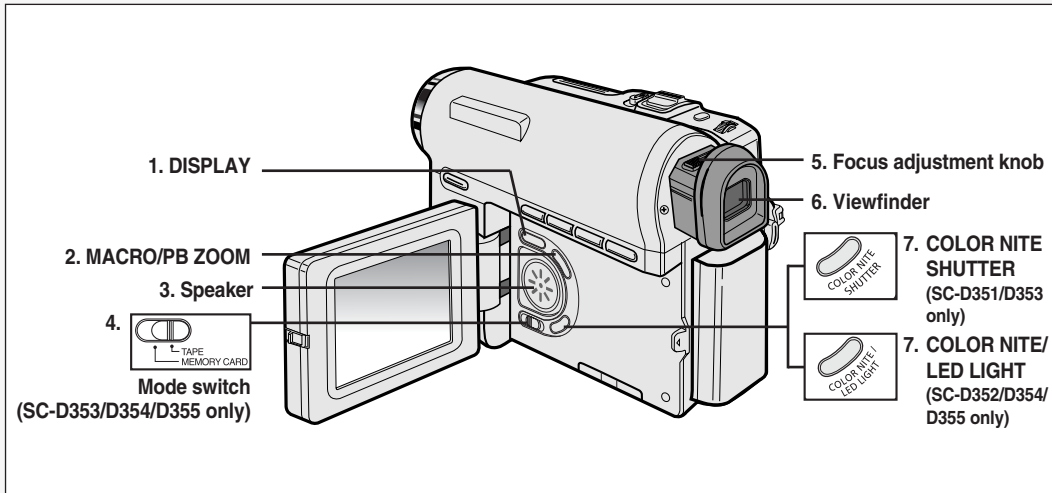

1. DISPLAY
2. MACRO/PB ZOOM
3. Speaker
4. Mode switch (MEMORY CARD/TAPE) (SC-D353/D354/D355 only)
5. Focus adjustment knob
6. Viewfinder
7. COLOR NITE SHUTTER (SC-D351/D353 only)
7. COLOR NITE/LED LIGHT (SC-D352/D354/D355 only)

Right & Top View

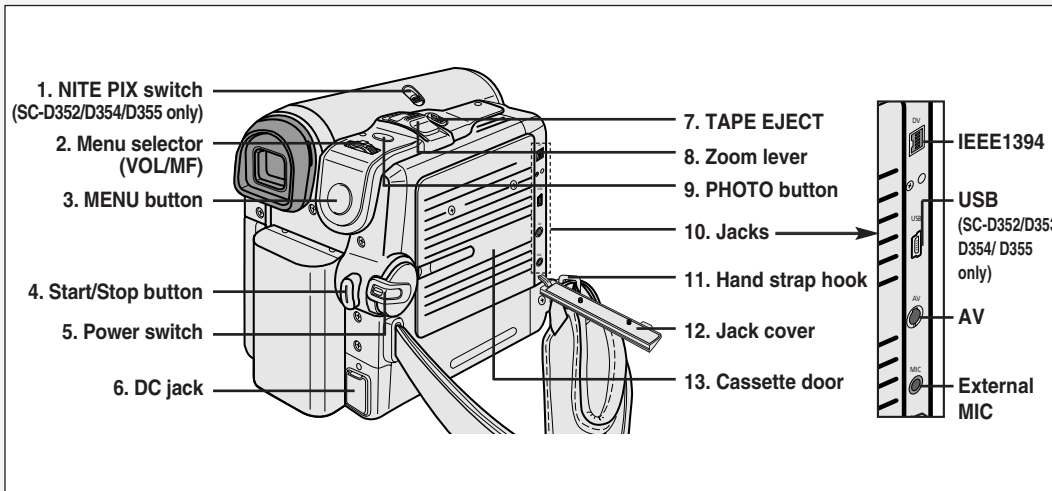

1. NITE PIX switch (SC-D352/D354/D355 only)
2. Menu selector (VOL/MF)
3. MENU button
4. Start/Stop button
5. Power switch (CAMERA or PLAYER)
6. DC jack
7. TAPE EJECT
8. Zoom lever
9. PHOTO button
10. Jacks
11. Hand strap hook
12. Jack cover
13. Cassette door

Rear & Bottom View

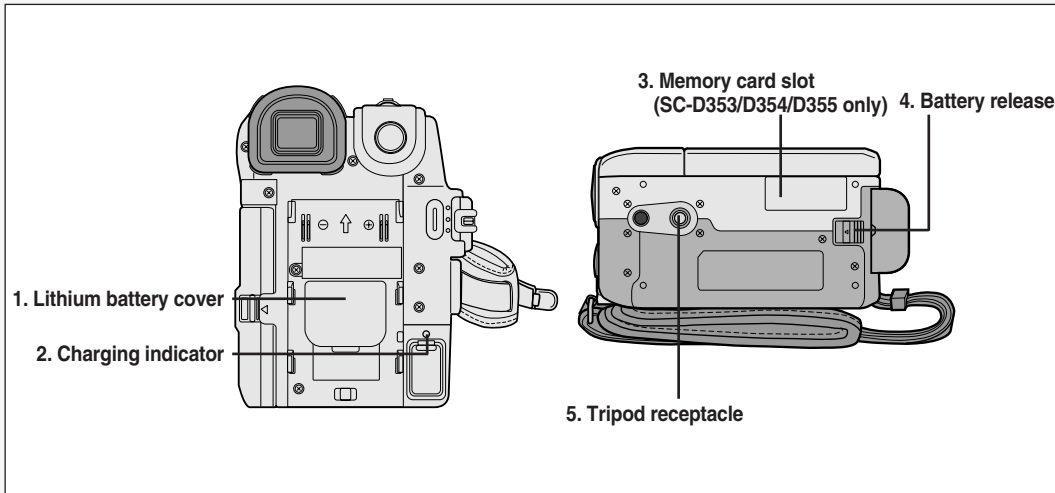

1. Lithium battery cover
2. Charging indicator
3. Memory card slot (SC-D353/D354/D355 only)
4. Battery release
5. Tripod receptacle

Memory Card slot (Usable Memory Card)

SC-D353/D354 only	SC-D355 only
 <p>Memory Stick Memory Stick PRO</p>	 <p>Memory Stick Memory Stick PRO</p>
	 <p>SD/MMC</p>

Remote Control

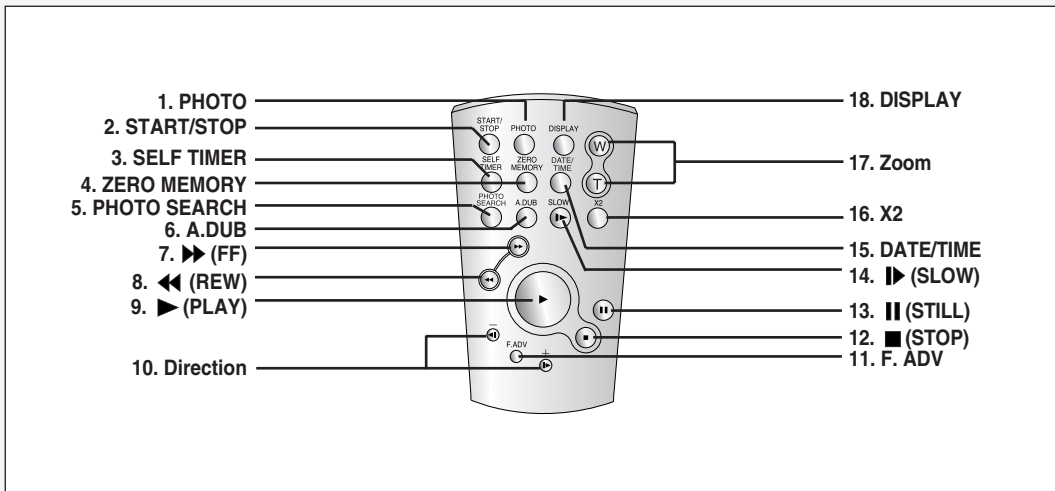

1. PHOTO
2. START/STOP
3. SELF TIMER
4. ZERO MEMORY
5. PHOTO SEARCH
6. A.DUB
7. ►► (FF)
8. ◀◀ (REW)
9. ► (PLAY)
10. Direction (◀||/||►)
11. F. ADV
12. ■ (STOP)
13. || (STILL)
14. ► (SLOW)
15. DATE/TIME
16. X2
17. Zoom
18. DISPLAY

Tape Playback

- ❖ The playback function works only in Player mode.

Playback on the LCD Screen

- ❖ It is practical to view a tape using the LCD screen when in a car or outdoors.

Playback on a TV Monitor

- ❖ To play back a tape, the television must be NTSC compatible.
- ❖ We recommend that you use the AC Power adapter as the power source for the Camcorder.

Connecting to a TV which has Audio/Video input jacks

1. Connect the Camcorder and TV with the Audio/Video cable.
 - The yellow jack: Video
 - The white jack: Audio(L)-mono
 - The red jack: Audio(R)
 - If you connect to a monaural TV, connect the yellow jack (Video) to the video input of the TV and the white jack (Audio L) to the audio input of the TV.

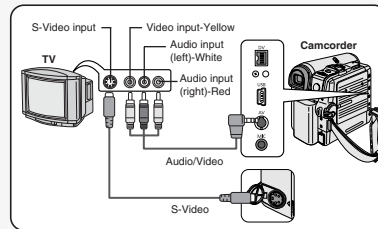

2. Set the **Power** switch to **PLAYER**.
3. Set the **Mode** switch to **TAPE**. (SC-D353/D354/D355 only)
4. Turn on the TV and set the TV/VIDEO selector on the TV to Video. Refer to the TV user's manual.
5. Play the tape.

Notes

- You may use an S-Video (optional) cable to obtain better quality pictures if you have a S-Video connector on your TV.
- Even if you use an S-Video (optional) cable, you need to connect an audio cable.
- If you connect the cable to the Audio/Video jack, you will not hear sound from the Camcorder's speakers.
- If only a mono audio input is available on the TV set, use the audio cable with the white jack (Audio L).

Connecting to a TV which has no Audio and Video Input Jacks

- ❖ You can connect your Camcorder to a TV through a VCR.

1. Connect the Camcorder to your VCR with the Audio/Video cable.
 - The yellow jack: Video
 - The white jack: Audio(L) - Mono
 - The red jack: Audio(R)
2. Connect a TV to the VCR.
3. Set the **Power** switch to **PLAYER**.
4. Set the **Mode** switch to **TAPE**. (SC-D353/D354/D355 only)
5. Turn on both the TV and VCR.
 - Set the input selector on the VCR to Line.
 - Select the channel reserved for your VCR on the TV set.
6. Play the tape.

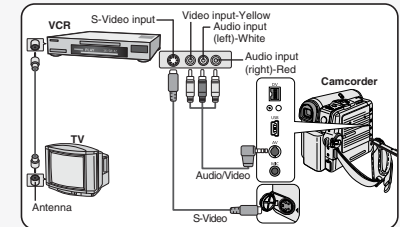

Playback

- ❖ You can play the recorded tape in Player mode.

1. Connect a power source and set the **Power** switch to **PLAYER**.
2. Set the **Mode** switch to **TAPE**. (SC-D353/D354/D355 only)
3. Insert the tape you wish to play back.
4. Using the ◀/▶ (REW/FF) buttons, find the first position you wish to play back.
5. Press the ▶/|| (PLAY/STILL) button.
 - The images you recorded will appear on the TV after a few seconds.
 - If a tape reaches its end while being played back, the tape will rewind automatically.

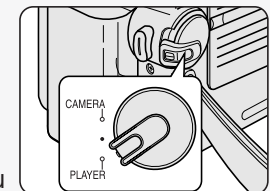

Note

- The playback mode (SP/LP) is selected automatically.
- If the VCR has an S-Video input terminal, you may use S-Video for better quality.
- The S-Video terminal transmits video only. Connect audio cables for sound.
- If only a mono audio input is available on the TV set, use the audio cable with the white jack (Audio L).

Making your First Recording

1. Connect a power source to the Camcorder.
(A Battery pack or a AC Power adapter)
 - Insert a cassette.
2. Remove the Lens cover.
3. Set the **Power** switch to **CAMERA**.
 - Open the **LCD** screen.
 - Set the **Mode** switch to **TAPE**.
(SC-D353/D354/D355 only)
Make sure that **STBY** is displayed.
 - If the write protection tab of the cassette is open (set to save), **STOP** and **Protection!** will be displayed.
Release the write protection tab to record.
 - Make sure the image you want to record appears on the LCD screen or Viewfinder.
 - Make sure the battery level indicates that there is enough remaining power for your expected recording time.
4. To start recording, press the **Start/Stop** button.
 - **REC ●** is displayed on the LCD screen.
 To stop recording, press the **Start/Stop** button again.
 - **STBY** is displayed on the LCD screen.

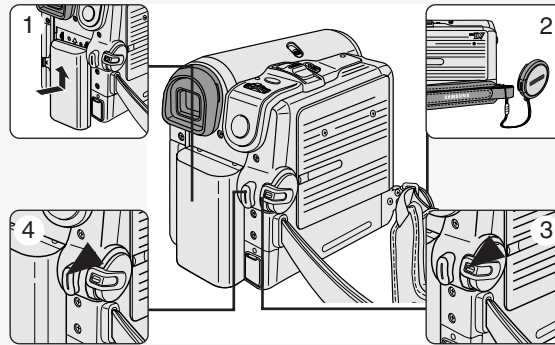

Notes

Detach the Battery pack when you are finished recording to prevent unnecessary battery power consumption.

Maintenance

Cleaning and Maintaining the Camcorder

Cleaning the Video Heads

To ensure normal recording and clear pictures, clean the video heads when the playback pictures display square block-shaped noise or distortion, or a blue screen appears.



1. Set the **Power** switch to **PLAYER**.
2. Set the **Mode** switch to **TAPE**. (SD-D353/D354/D355 only)
3. Insert the cleaning tape.
4. Press the **▶/II** (PLAY/STILL) button.
5. Press the **■** (STOP) button after 10 seconds.

Notes

- Check the quality of the picture using a videocassette.
- If the picture quality has not improved, repeat the operation.
- Clean the video heads with a dry type cassette cleaner.
- Some cleaning cassette products stop automatically. Refer to the cleaning cassette's instructions for detailed information. If the problem continues after the cleaning, consult your nearest Samsung dealer or Authorized Service Center.

Troubleshooting

- ❖ Before contacting a Samsung authorized service center, perform the following simple checks. They may save you the time and expense of an unnecessary call.

Self Diagnosis Display

Display	Blinking	Informs that..	Action
	slow	the Battery pack is almost discharged.	Change to a charged one.
Tape end!	slow	When the remaining time on the tape is about 2 minutes.	Prepare a new one.
Tape end!	no	the tape reached its end.	Change to a new one.
No Tape!	slow	there is no tape in Camcorder.	Insert a tape.
Protection!	slow	the tape is protected from recording.	If you want to record, release the protection.
▲...D L C R	slow	the Camcorder has some mechanical fault.	1. Eject the tape. 2. Set to OFF. 3. Detach the battery. 4. Reattach the battery. * If unresolved contact your local samsung service center.
	slow	moisture condensation has formed in the Camcorder.	see below.

Moisture Condensation

- ❖ If the Camcorder is brought directly from a cold place to a warm place, moisture may condense inside the Camcorder, on the surface of the tape, or on the lens. In this condition, the tape may stick to the head drum and be damaged or the unit may not operate correctly. To prevent possible damage under these circumstances, the Camcorder is fitted with a moisture sensor.
- ❖ If there is moisture inside the Camcorder, (DEW) is displayed. If this happens, none of the functions except cassette ejection will work. Open the cassette compartment and remove the battery. Leave the Camcorder for at least two hours in a dry warm room.

Self Diagnosis Display in M.Cam/M.Player Modes (SC-D353/D354/D355 only)

Display	Blinking	Informs that..	Action
No Memory Card!	slow	There is no Memory card in the Camcorder.	Insert a Memory card.
Memory Full!	slow	There is not enough memory to record.	Change to a new Memory card. Erase recorded image.
No image!	slow	There are no images recorded on the Memory card.	Record new images.
Write protect!	slow	The Memory card is record protected.	Release the write protect tab on the Memory card.
Protect!	slow	When you try to delete to protected image.	Cancel the protection of image.
Read error!	slow	The Camcorder can not playback.	Format a Memory card or insert Memory card recorded on this Camcorder.
Write error!	slow	The Camcorder can not record.	Format a Memory card or change to a new Memory card.
Not Formatted!	slow	The Memory card needs to format.	Format a Memory card. (see page 101)
Now deleted...	slow	When progressing file delete.	Wait until delete has been finished.
Memory Card error!	slow	If inserted Memory Card is not recognized by the Camcorder.	Eject and re-insert the memory card Try another Memory Card

Direct Print Related Messages

Display	Explanation
Paper error	There is a problem with the paper.
No paper	Paper is not correctly inserted or there is no paper.
Paper Jam	The paper jammed during printing.
Ink error	There is a problem with the ink cassette.
No Ink	The ink cartridge is not inserted or is out of ink.
Print error	Turn off the printer and turn it back on.
File error	You attempted to print an image that was made with another camcorder, has a different format, or was edited on a computer.