

Patent Pending

Model No. RBEX39010

Serial No. \_\_\_\_\_

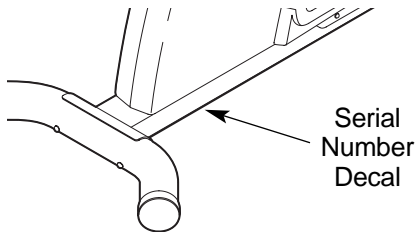

## QUESTIONS?

As a manufacturer, we are committed to providing complete customer satisfaction. If you have questions, or if there are missing or damaged parts, we will guarantee complete satisfaction through direct assistance from our factory.

**TO AVOID UNNECESSARY DELAYS, PLEASE CALL DIRECT TO OUR TOLL-FREE CUSTOMER HOT LINE.** The trained technicians on our customer hot line will provide immediate assistance, free of charge to you.

**CUSTOMER HOT LINE:**

**1-800-999-3756**

Mon.-Fri., 6 a.m.-6 p.m. MST

## CAUTION

Read all precautions and instructions in this manual before using this equipment. Keep this manual for future reference.

# USER'S MANUAL

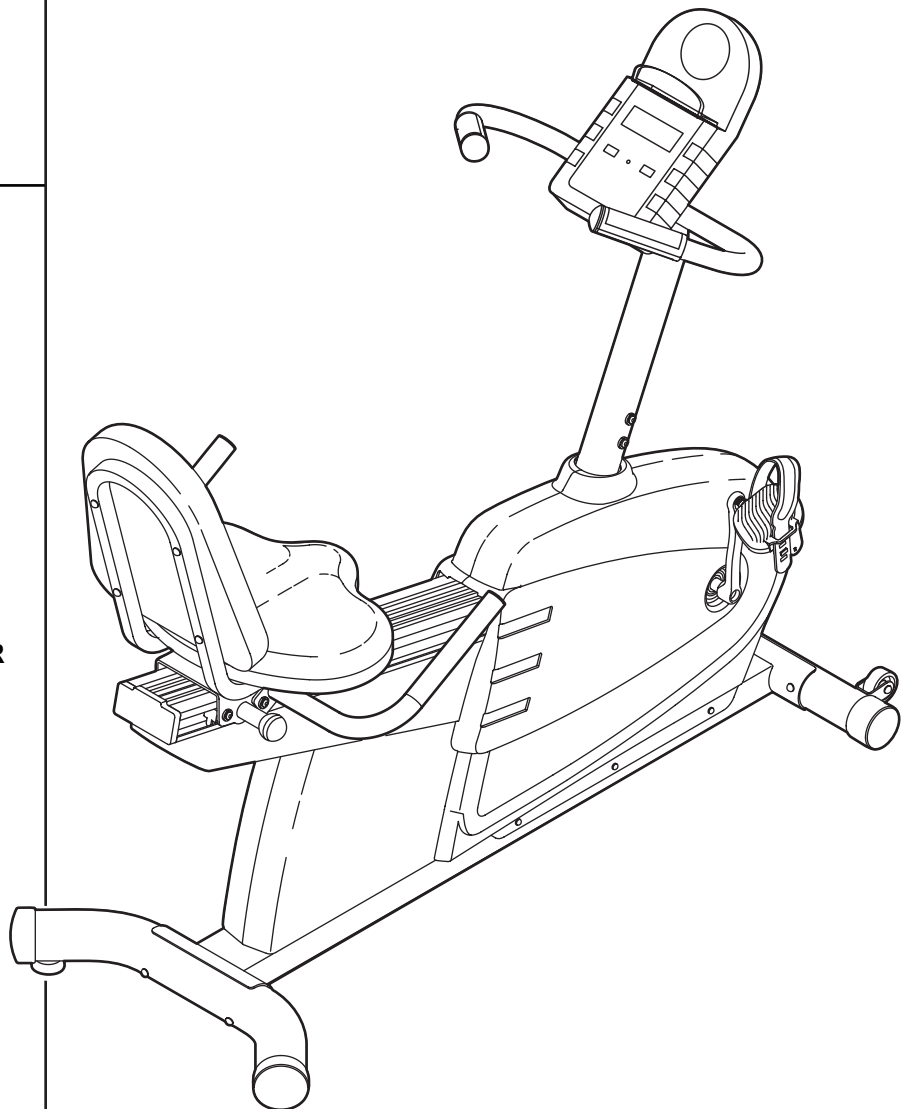

Visit our website at

[www.reebokhomefitness.com](http://www.reebokhomefitness.com)

*new products, prizes,  
fitness tips, and much more!*

# TABLE OF CONTENTS

IMPORTANT PRECAUTIONS	.2
BEFORE YOU BEGIN	.3
ASSEMBLY	.4
HOW TO OPERATE THE EXERCISE CYCLE	.8
MAINTENANCE AND TROUBLESHOOTING	.11
EXERCISE GUIDELINES	.12
PART LIST	.14
EXPLODED DRAWING	.15
HOW TO ORDER REPLACEMENT PARTS	.Back Cover
LIMITED WARRANTY	.Back Cover

## IMPORTANT PRECAUTIONS

**⚠ WARNING:** To reduce the risk of serious injury, read the following important precautions before using the REEBOK® CYC12 exercise cycle.

1. Read all instructions in this manual before using the exercise cycle.
2. It is the responsibility of the owner to ensure that all users of the exercise cycle are adequately informed of all precautions. Use the exercise cycle only as described in this manual.
3. Use the exercise cycle indoors on a level surface. Keep the exercise cycle away from moisture and dust. Place a mat under the exercise cycle to protect the floor or carpet.
4. Inspect and properly tighten all parts regularly. Replace any worn parts immediately.
5. Keep children under the age of 12 and pets away from the exercise cycle at all times.
6. The exercise cycle should not be used by persons weighing more than 250 pounds.
7. Wear appropriate clothing when exercising; do not wear loose clothing that could become caught on the exercise cycle. Always wear athletic shoes when using the exercise cycle.
8. Always keep your back straight when using the exercise cycle; do not arch your back.
9. If you feel pain or dizziness while exercising, stop immediately and cool down.
10. The pulse sensor is not a medical device. Various factors, including the user's movement, may affect the accuracy of heart rate readings. The pulse sensor is intended only as an exercise aid in determining heart rate trends in general.
11. The exercise cycle is intended for home use only. Do not use the exercise cycle in a commercial, rental, or institutional setting.

**⚠ WARNING:** Before beginning this or any exercise program, consult your physician. This is especially important for persons over the age of 35 or persons with pre-existing health problems. Read all instructions before using. ICON assumes no responsibility for personal injury or property damage sustained by or through the use of this product.

# BEFORE YOU BEGIN

Congratulations for selecting the new REEBOK® CYC12 exercise cycle. Cycling is one of the most effective exercises for increasing cardiovascular fitness, building endurance, and toning the entire body. The REEBOK® CYC12 offers an impressive array of features designed to let you enjoy this healthful exercise in the comfort and privacy of your home.

**For your benefit, read this manual carefully before you use the exercise cycle.** If you have additional questions, please call our Customer Service

Department toll-free at 1-800-999-3756, Monday through Friday, 6 a.m. until 6 p.m. Mountain Time (excluding holidays). To help us assist you, please mention the product model number and serial number when calling. The model number is RBEX39010. The serial number can be found on a decal attached to the exercise cycle (see the front cover of this manual).

Before reading further, please familiarize yourself with the parts that are labeled in the drawing below.

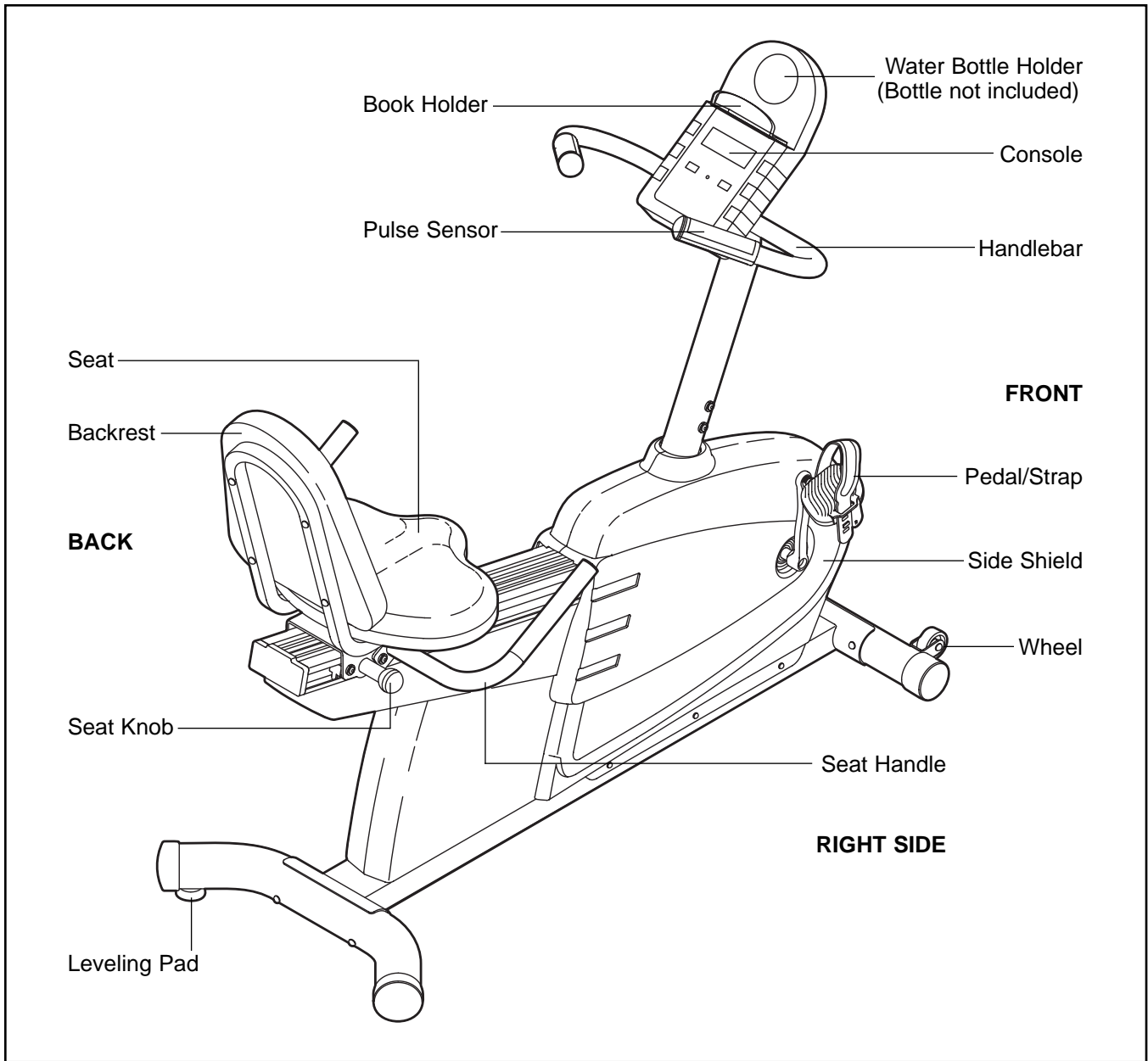

# ASSEMBLY

**Assembly requires two persons.** Place all parts of the exercise cycle in a cleared area and remove the packing materials. Do not dispose of the packing materials until assembly is completed.

**Assembly requires the included tools and your own adjustable wrench**  .

Use the part drawings below to identify the small parts used in assembly. The number in parenthesis below each drawing refers to the key number of the part, from the PART LIST on page 14. The second number refers to the quantity used in assembly. **Note: Some small parts may have been pre-attached for shipping. If a part is not in the parts bag, check to see if it has been pre-assembled.**

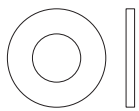

M6 Washer  
(25)–6

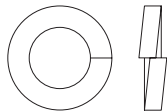

M8 Split  
Washer (70)–4

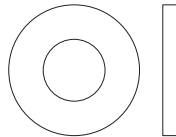

M8 Flat  
Washer (18)–4



M8 Nylon  
Locknut (56)–4

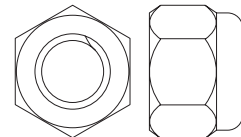

M10 Nylon  
Locknut (45)–4



M4 x 16mm  
Screw (90)–4

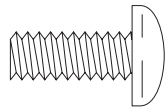

M6 x 16mm  
Screw (85)–2

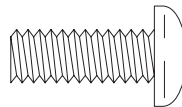

M8 x 19mm Button  
Bolt (43)–4

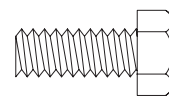

M6 x 16mm Hex  
Screw (29)–4

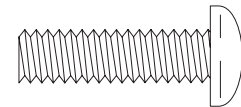

M8 x 25mm Button  
Screw (27)–4

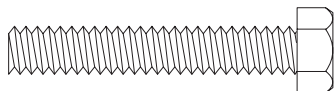

M6 x 38mm Hex  
Screw (78)–4

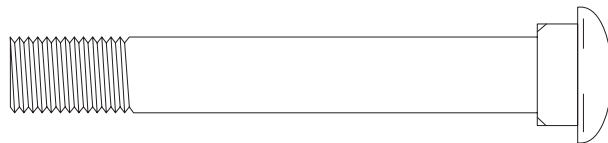

M10 x 75mm Carriage Bolt (72)–2

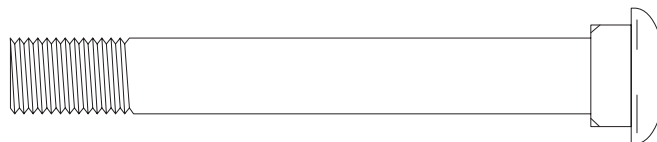

M10 x 82mm Carriage Bolt (63)–2

1. Identify the Front Stabilizer (2), which has Wheels (75) near its ends. Attach the Front Stabilizer to the front of the Frame (1) with two M10 x 75mm Carriage Bolts (72) and two M10 Nylon Locknuts (45). **Make sure that the Front Stabilizer is turned so the Wheels are not touching the floor.**

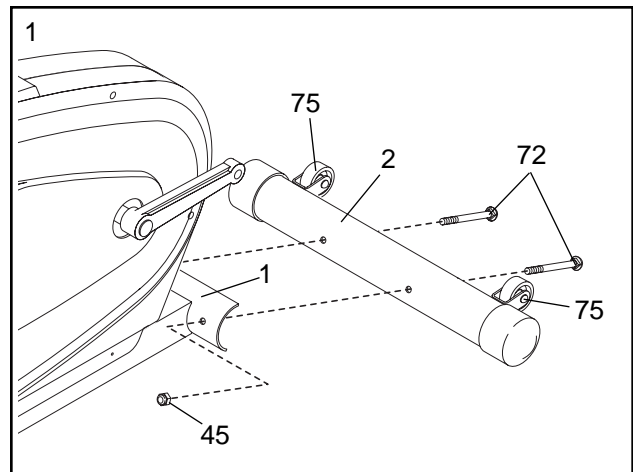

2. Attach the Rear Stabilizer (3) to the rear of the Frame (1) with two M10 x 82mm Carriage Bolts (63) and two M10 Nylon Locknuts (45).

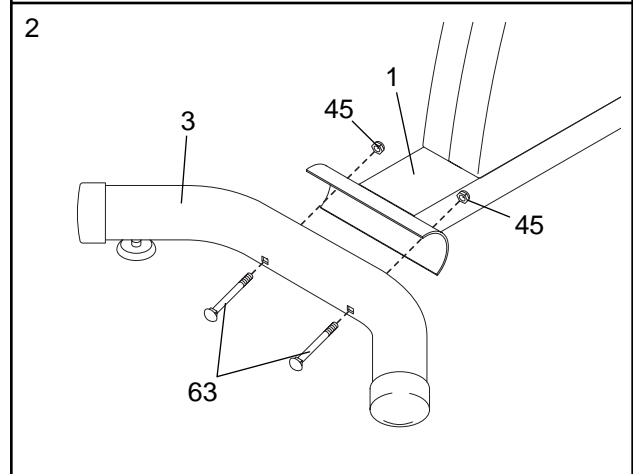

3. While a second person holds the Handlebar Post (6) near the Frame (1) as shown, connect the Upper Wire Harness (16) to the Lower Wire Harness (77).

Carefully slide the Handlebar Post (6) onto the Frame (1); **be careful to avoid pinching the Wire Harnesses (16, 77)**. Attach the Handlebar Post to the Frame with four M8 x 25mm Button Screws (27) and four M8 Split Washers (70).

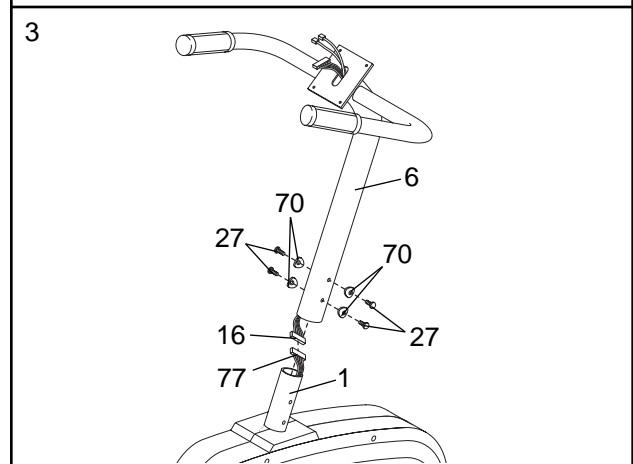

4. Connect the two Pulse Wires (86) to the two wires extending from the Console (9). Next, connect the Upper Wire Harness (16) to the back of the Console. Insert all wires into the Handlebar Post (6).

Attach the Console (9) to the Handlebar Post (6) with four M4 x 16mm Screws (90). **Be careful to avoid pinching the wires.**

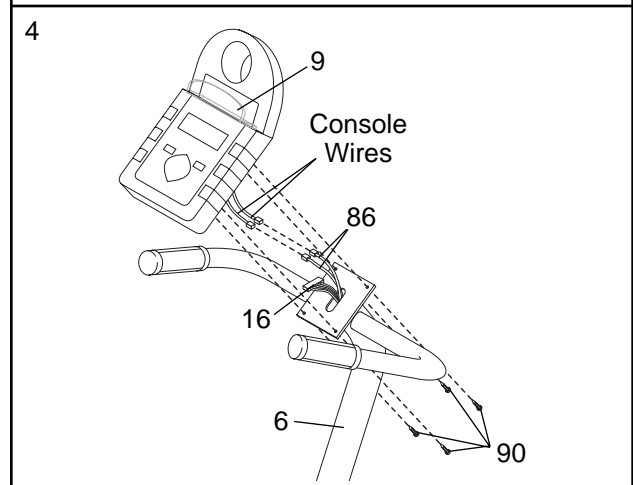

- Attach the Seat (12) to the Seat Carriage (11) with four M6 x 16mm Hex Screws (29) and four M8 Flat Washers (18).

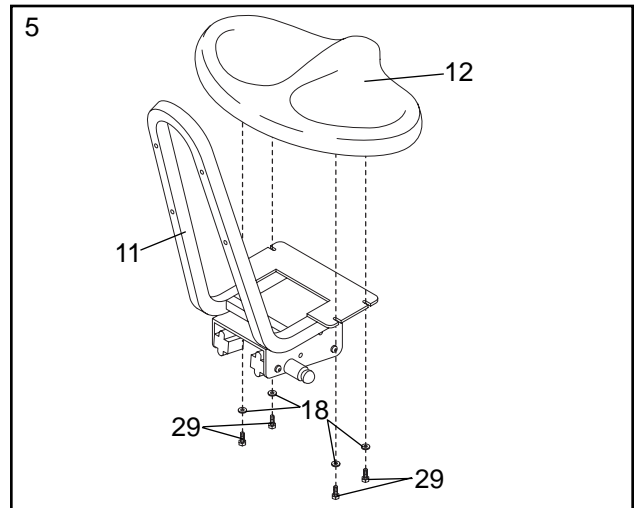

- Attach a Seat Handle (14) to the Seat Carriage (11) with two M8 x 19mm Button Bolts (43) and two M8 Nylon Locknuts (56).

Attach the other Seat Handle (14) to the Seat Carriage (11) in the same way.

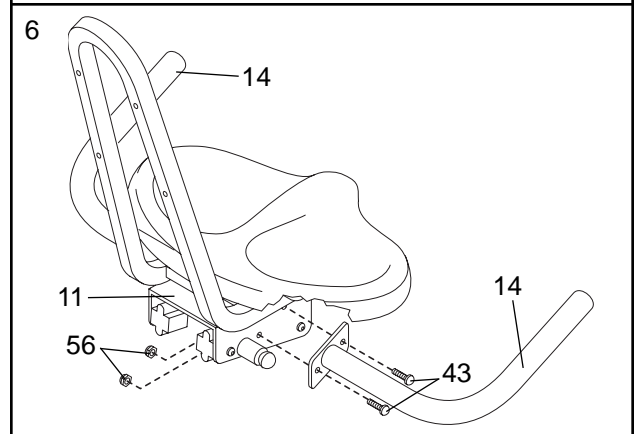

- Attach the Backrest (13) to the Seat Carriage (11) with four M6 x 38mm Hex Screws (78) and four M6 Washers (25).

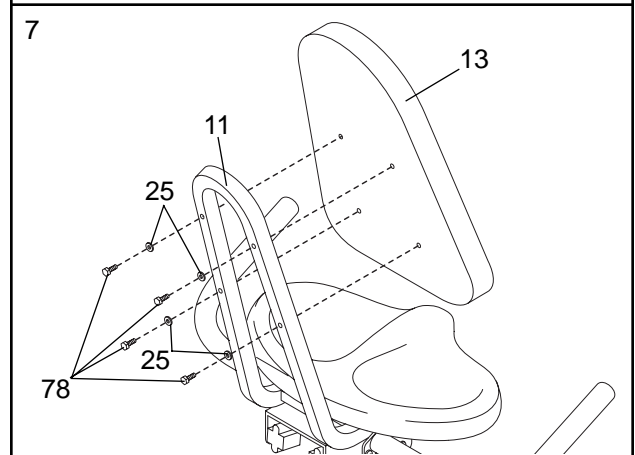

- Pull the seat knob and slide the Seat Carriage (11) onto the Seat Rail (7).

Refer to the inset drawing. Hold the Bumper Axle (82) inside of the Seat Rail (7). Attach the two Bumpers (84) to the ends of the Bumper Axle with two M6 x 16mm Screws (85) and two M6 Washers (25) as shown. Press the Seat Rail Endcap (23) into the end of the Seat Rail.

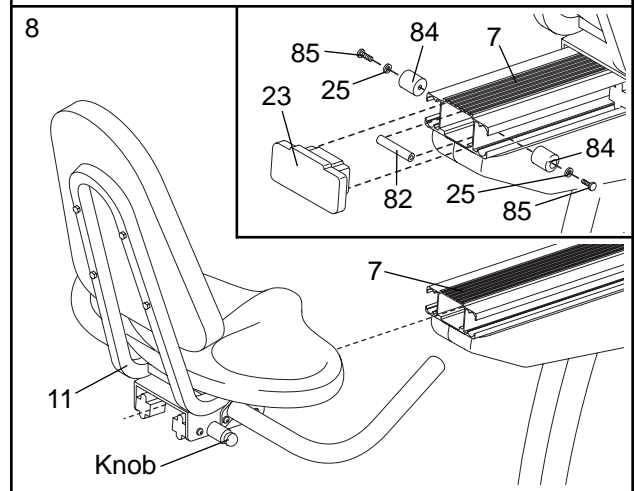

9. Firmly tighten the four M8 x 31mm Button Screws (80) in the Seat Carriage (11).

Pull the seat knob and slide the Seat Carriage (11) to the desired position. Release the seat knob and **slide the Seat Carriage back and forth slightly until it locks into position.**

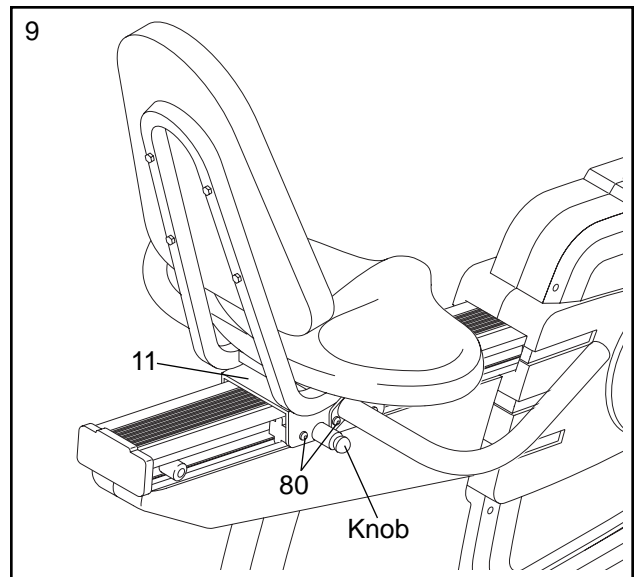

10. Identify the Right Pedal (37), which is marked with an "R." Using an adjustable wrench, tighten the Right Pedal *clockwise* into the Right Crank Arm (65). Tighten the Left Pedal *counterclockwise* into the Left Crank Arm (not shown).

Adjust the Right Pedal Strap (38) to the desired position, and press the end of the Pedal Strap onto the tab on the Right Pedal (37). Adjust the Left Pedal Strap (not shown) in the same way.

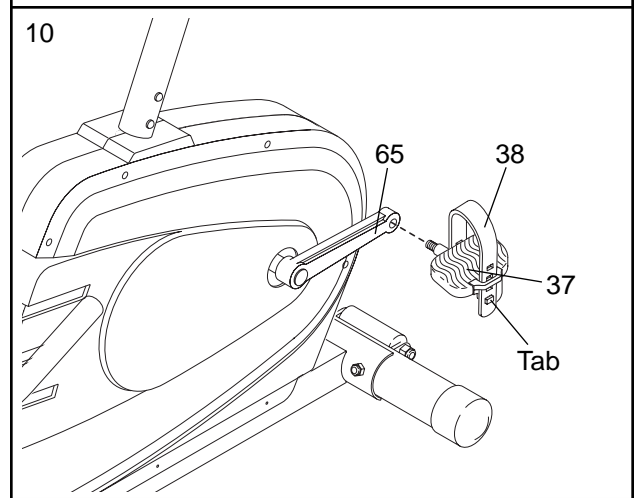

11. **Make sure that all parts are tightened before you use the exercise cycle. Place a mat beneath the exercise cycle to protect the floor.**

# HOW TO OPERATE THE EXERCISE CYCLE

## HOW TO ADJUST THE POSITION OF THE SEAT

For effective exercise, the seat should be in the proper position. As you pedal, there should be a slight bend in your knees when the pedals are in the farthest position.

To adjust the seat, pull the seat knob and slide the seat carriage to the desired position. Release the seat knob and **slide the seat carriage back and forth slightly until it locks into position.**

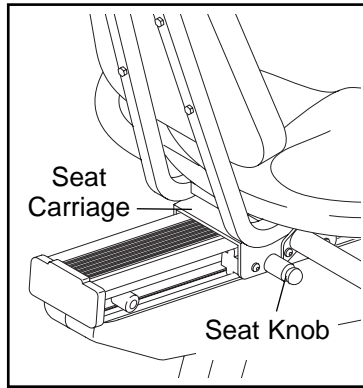

## HOW TO ADJUST THE PEDAL STRAPS

To adjust the pedal straps, first pull the ends of the straps off the tabs on the pedals. Adjust the straps to the desired positions, and then press the straps back onto the tabs.

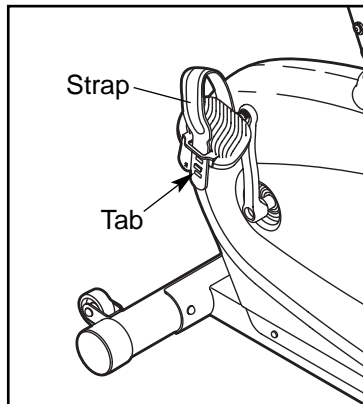

## DESCRIPTION OF THE CONSOLE

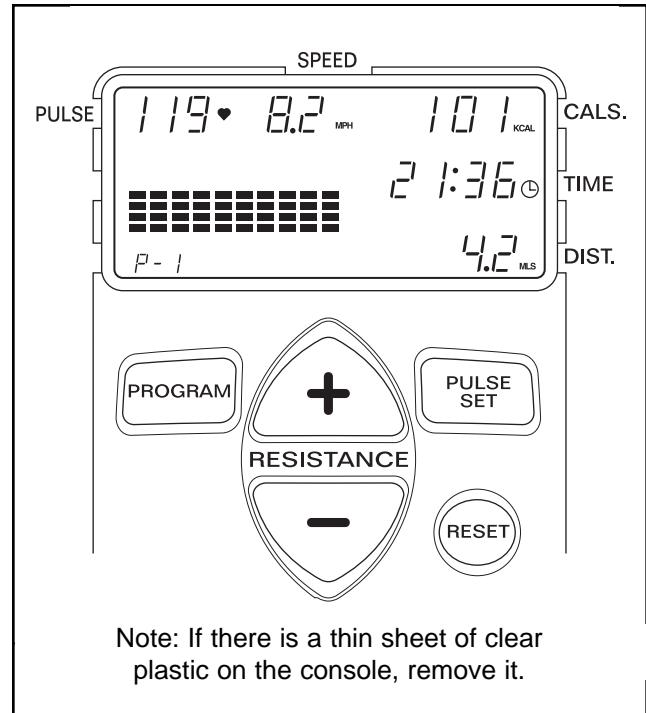

The innovative console offers an array of features designed to help you get the most from your workouts. When the manual program is selected, you can adjust the pedaling resistance with a touch of a button. As you exercise, the console will display your pedaling speed, the number of Calories you have burned, the elapsed time, and the distance you have pedaled. The console will also display your heart rate when you use the built-in pulse sensor.

The console also offers five preset workout programs. Each program automatically changes the pedaling resistance as it guides you through an effective workouts.



## HOW TO USE THE MANUAL PROGRAM

### 1 Begin pedaling to activate the console.

The exercise cycle requires no batteries or external power source. Instead, power is supplied by a generator as you pedal. To activate the console, begin pedaling. After a few seconds, the entire display will appear for a moment. The console will then be ready for use. **Note: Before the resistance buttons can be operated, you may have to pedal for up to five minutes.**

### 2 Set a heart rate goal, if desired.

If you do not wish to set a heart rate goal for your workout, go to step 3.

**To set a maximum heart rate goal,** first press the Pulse Set button. The High (H) indicator will appear in the display. Next,

press the Resistance + and – buttons to set a maximum heart rate goal, in beats per minute (refer to EXERCISE GUIDELINES on page 12). Each time a button is pressed, the goal will change by 5 beats per minute. Five seconds after you set a goal, the High indicator will disappear.

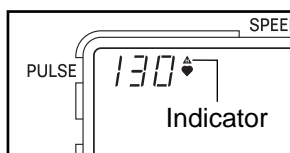

**To set a minimum heart rate goal,** press the Pulse Set button twice. The Low (L) indicator will appear. Next, press

the Resistance + and – buttons to set a minimum heart rate goal, in beats per minute (refer to EXERCISE GUIDELINES on page 12). Each time a button is pressed, the goal will change by 5 beats per minute. Five seconds after you set a goal, the Low indicator will disappear.

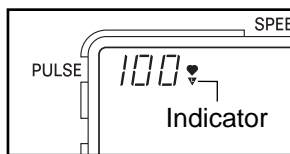

If you set a maximum or minimum heart rate goal, the console will sound a tone to alert you and the High or Low indicator will flash if your heart rate is above your maximum goal or below your minimum goal when you use the pulse sensor. **Important: Always make sure to exercise at a pace that is comfortable for you.**

To cancel a heart rate goal, first press the Pulse Set button until the High or Low indicator appears. Then, press the Reset button.

### 3 Select the manual program.

Each time the power is turned on, the manual program will automatically be selected, as shown by the “P-1” in the display. (P-1 is the manual program.) If you have selected a different program, select the manual mode again by pressing the Program button repeatedly until the “P-1” reappears.

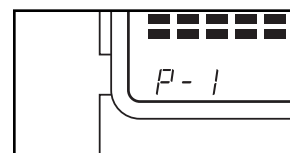

### 4 Adjust the resistance of the pedals as desired.

As you exercise, press the Resistance + and – buttons to adjust the resistance of the pedals. There are eight resistance settings. Note: After the buttons are pressed, it may take a moment for the pedals to reach the selected resistance setting.

### 5 Follow your progress with the console display.

As you exercise, the matrix on the left side of the display will show your progress. During the first minute that you pedal, the first column of the matrix will flash.

During the second minute, the second column will flash, and so forth, until the tenth column is flashing. After you have pedaled for ten minutes, the first column will again flash.

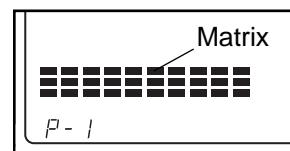

The matrix will also show the resistance level of the pedals. Each time you press the Resistance + or – button, the height of the columns in the matrix will increase or decrease.

In addition to the matrix, the display will show your pedaling speed, the number of Calories you have burned, the elapsed time, and the distance you have pedaled. The display will also show your heart rate when you use the pulse sensor (refer to step 6 on page 10).

Note: The console can display speed and distance in either miles or kilometers. The letters “MPH” or “KMH” will appear in the display to show which unit of measurement is selected. To change the unit of measurement, refer to HOW TO SELECT MILES OR KILOMETERS on page 11.

To reset the display, press the Reset button for three seconds.

## 6 Measure your heart rate, if desired.

**Note: If the metal contacts on the pulse sensor are covered with thin sheets of plastic, remove the plastic.**

To use the pulse sensor, place your hands on the metal contacts. Your palms must be touching the contacts closest to you and your fingers must be touching the opposite contacts. **Avoid moving your hands or squeezing the contacts too tightly.** After a moment, the heart indicator in the display will begin to flash and then your heart rate will be shown. For the most accurate heart rate reading, continue to hold the contacts for about 15 seconds.

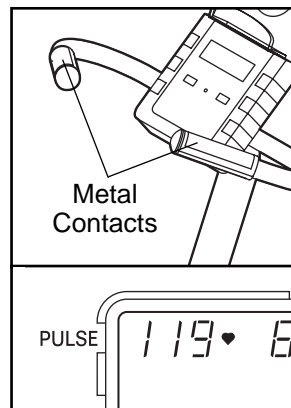

## 7 When you are finished exercising, turn off the power

**To turn off the power, simply wait for a few minutes.** If the pedals are not moved and the console buttons are not pressed for a few minutes, the power will turn off automatically.

### HOW TO USE A PRESET PROGRAM

#### 1 Begin pedaling to activate the console.

Refer to step 1 on page 9.

#### 2 Set a heart rate goal, if desired.

Refer to step 2 on page 9.

#### 3 Select one of the preset workout programs

Each time the power is turned on, the manual program will be selected. To select one of the preset programs, press the Program button repeatedly until a “P-2,” “P-3,” “P-4,” “P-5,” or “P-6” appears in the display.

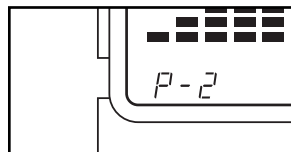

As you select each preset program, the matrix will show the resistance settings of the program you have selected. If you select program 2, for example, the matrix will show that the resistance will gradually increase during the first half of the program and then gradually decrease during the last half of the program.

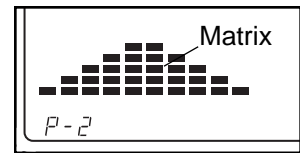

#### 4 Follow your progress with the console display.

As you exercise, follow your progress with the matrix on the left side of the display. During the first minute of the program, the first column of the matrix will flash. During the second minute, the second column will flash, and so forth. In addition, the resistance of the pedals will automatically change according to the height of the flashing column—the higher the column is, the greater the resistance will be. After ten minutes, the program will be completed. If you continue exercising, the first column will again flash.

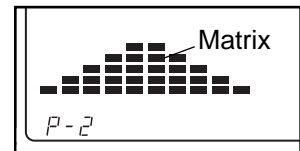

**Note:** If the program is too easy or too difficult, press the Resistance + or – button to adjust the intensity level of the program. Each time you press a button, the height of all of the columns in the matrix will increase or decrease.

In addition to the matrix, the display will show your pedaling speed, the number of Calories you have burned, the elapsed time, and the distance you have pedaled. The display will also show your heart rate when you use the pulse sensor.

#### 5 Measure your heart rate, if desired.

Refer to step 6 at the left.

#### 6 When you are finished exercising, turn off the power.

Refer to step 7 at the left.

## HOW TO SELECT MILES OR KILOMETERS

The console can display speed and distance in either miles or kilometers. The letters “MPH” or “KMH” will appear in the display to show which unit of measurement is selected. To change the unit of

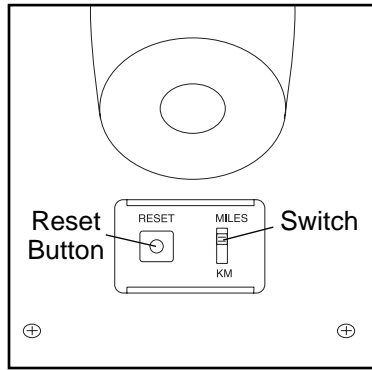

measurement, first remove the access door from the back of the console. Locate the Reset button and the switch inside the console. Slide the switch up or down to select miles or kilometers, and then press the Reset button. Reattach the access door to the back of the console.

## MAINTENANCE AND TROUBLESHOOTING

Inspect and tighten all parts of the exercise cycle regularly. The exercise cycle can be cleaned with a soft, damp cloth. To prevent damage to the console, keep liquids away from the console and keep the console out of direct sunlight.

Inspect and properly tighten all parts of the exercise cycle regularly. Make sure to keep the indicated screws tight (there are two screws on each side). In addition, make sure to keep the pedals tightened.

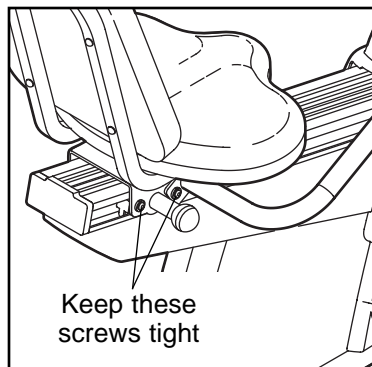

### HOW TO LEVEL THE EXERCISE CYCLE

If the exercise cycle does not sit flat on the floor, turn one or both of the leveling pads until the exercise cycle is level.

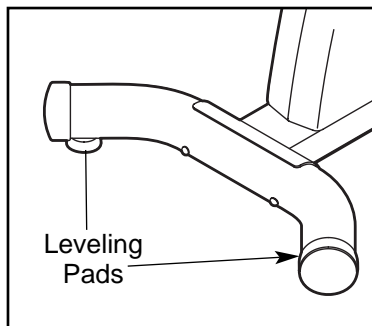

### PULSE SENSOR TROUBLESHOOTING

- Avoid moving your hands while using the pulse sensor. Excessive movement may interfere with heart rate readings.
- If your heart rate is not shown when the pulse sensor is used, press the resistance – button to reset the display.
- Do not hold the metal contacts too tightly; doing so may interfere with heart rate readings.
- For the most accurate heart rate reading, hold the metal contacts for about 15 seconds.
- For optimal performance of the pulse sensor, keep the metal contacts clean. The contacts can be cleaned with a soft cloth—never use alcohol, abrasives, or chemicals.

# EXERCISE GUIDELINES

**⚠ WARNING:** Before beginning this or any exercise program, consult your physician. This is especially important for individuals over the age of 35 or individuals with pre-existing health problems.

The pulse sensor is not a medical device. Various factors may affect the accuracy of heart rate readings. The pulse sensor is intended only as an exercise aid in determining heart rate trends in general.

Exercise has proven essential for good health and well-being. Regular participation in a well-rounded exercise program results in a stronger and more efficient heart, improved respiratory function, increased stamina, better weight management, increased ability to deal with stress, and greater self-esteem.

## EXERCISE INTENSITY

To maximize the benefits of exercising, it is important to exercise with the proper intensity. The proper intensity level can be found by using your heart rate as a guide. For effective aerobic exercise, your heart rate should be maintained at a level between 70% and 85% of your maximum heart rate as you exercise. This is known as your training zone. You can find your training zone in the table below. Training zones are listed according to age and physical condition.

AGE	TRAINING ZONE (BEATS/MIN.)	
	UNCONDITIONED	CONDITIONED
20	138–167	133–162
25	136–166	132–160
30	135–164	130–158
35	134–162	129–156
40	132–161	127–155
45	131–159	125–153
50	129–156	124–150
55	127–155	122–149
60	126–153	121–147
65	125–151	119–145
70	123–150	118–144
75	122–147	117–142
80	120–146	115–140

During the first few months of your exercise program, keep your heart rate near the low end of your training zone as you exercise. After a few months of regular exercise, your heart rate can be increased until it is near the middle of your training zone as you exercise.

To measure your heart rate, use the built-in pulse sensor. You can also measure your heart rate by placing two fingers on your wrist as shown. Stop exercising and take a six-second heartbeat count.

Multiply the result by ten to find your heart rate. (A six-second count is used because your heart rate drops quickly when you stop exercising.) If

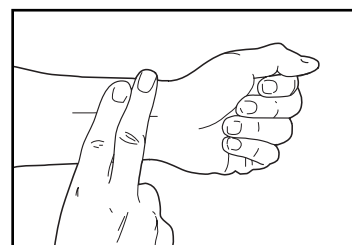

your heart rate is too high, decrease the intensity of your exercise. If your heart rate is too low, increase the intensity of your exercise.

## WORKOUT GUIDELINES

A well-rounded workout includes three important parts:

**A warm-up**, consisting of 5 to 10 minutes of stretching and light exercise. A proper warm-up increases your body temperature, heart rate, and circulation in preparation for exercise.

**Training zone exercise**, consisting of 20 to 40 minutes of exercising with your heart rate in your training zone. (During the first few weeks of your exercise program, do not keep your heart rate in your training zone for longer than 20 minutes.)

**A cool-down**, with 5 to 10 minutes of stretching. This will increase the flexibility of your muscles and will help to prevent post-exercise problems.

## EXERCISE FREQUENCY

To maintain or improve your condition, plan three workouts each week, with at least one day of rest between workouts. After a few months of regular exercise, you may complete up to five workouts each week, if desired. **CAUTION: Be sure to progress at your own pace and avoid overdoing it. Incorrect or excessive training may result in injury to your health.**

Remember, the key to success is make exercise a regular and enjoyable part of your everyday life.

## SUGGESTED STRETCHES

The correct form for several basic stretches is shown at the right. Move slowly as you stretch—never bounce.

### 1. Toe Touch Stretch

Stand with your knees bent slightly and slowly bend forward from your hips. Allow your back and shoulders to relax as you reach down toward your toes as far as possible. Hold for 15 counts, then relax. Repeat 3 times. Stretches: Hamstrings, back of knees and back.

### 2. Hamstring Stretch

Sit with one leg extended. Bring the sole of the opposite foot toward you and rest it against the inner thigh of your extended leg. Reach toward your toes as far as possible. Hold for 15 counts, then relax. Repeat 3 times for each leg. Stretches: Hamstrings, lower back and groin.

### 3. Calf/Achilles Stretch

With one leg in front of the other, reach forward and place your hands against a wall. Keep your back leg straight and your back foot flat on the floor. Bend your front leg, lean forward and move your hips toward the wall. Hold for 15 counts, then relax. Repeat 3 times for each leg. To cause further stretching of the achilles tendons, bend your back leg as well. Stretches: Calves, achilles tendons and ankles.

### 4. Quadriceps Stretch

With one hand against a wall for balance, reach back and grasp one foot with your other hand. Bring your heel as close to your buttocks as possible. Hold for 15 counts, then relax. Repeat 3 times for each leg. Stretches: Quadriceps and hip muscles.

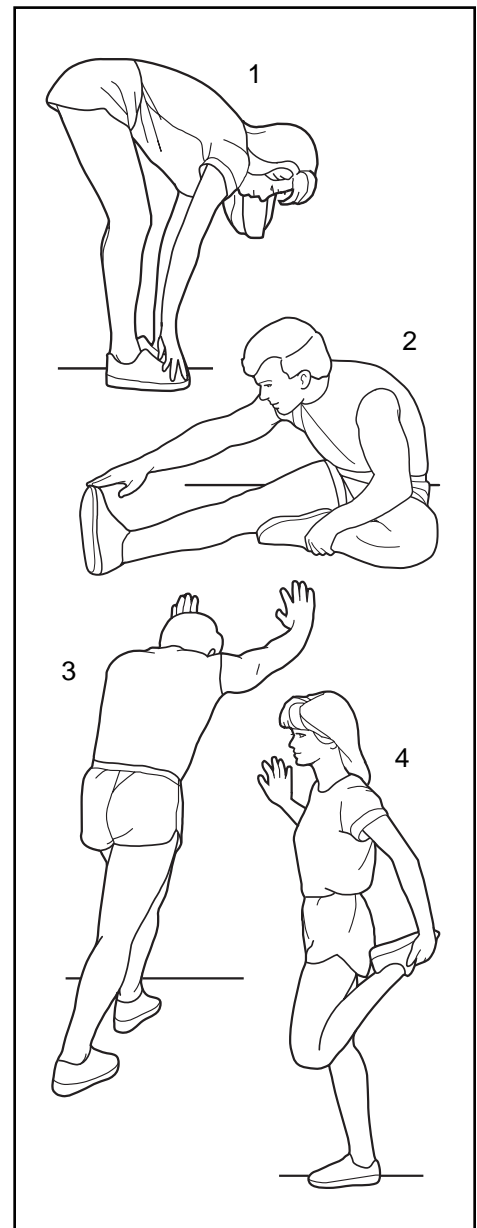

# PART LIST—MODEL NO. RBEX39010

R1101A

Key No.	Qty.	Description	Key No.	Qty.	Description	Key No.	Qty.	Description
1	1	Frame	33	1	Crank	65	1	Right Crank Arm
2	1	Front Stabilizer	34	1	Left Crank Arm	66	1	Flywheel Axle
3	1	Rear Stabilizer	35	2	M8 x 25.4mm Flange Screw	67	1	"J" Bolt
4	1	Left Side Shield	36	2	Crank Cap	68	1	Belt
5	1	Right Side Shield	37	1	Right Pedal	69	1	Access Door
6	1	Handlebar Post	38	1	Right Pedal Strap	70	8	M8 Split Washer
7	1	Seat Rail	39	1	Generator	71	2	Handgrip Pulse Sensor
8	1	"C" Magnet	40	1	Left Pedal	72	2	M10 x 75mm Carriage Bolt
9	1	Console	41	1	Left Pedal Strap	73	2	Snap Ring
10	2	Handlebar Foam	42	2	Front Stabilizer Endcap	74	1	Freewheel Bearing
11	1	Seat Carriage	43	4	M8 x 19mm Button Bolt	75	2	Wheel
12	1	Seat	44	1	Reed Switch/Wire	76	2	M10 x 45mm Bolt
13	1	Backrest	45	8	M10 Nylon Locknut	77	1	Lower Wire Harness
14	2	Seat Handle	46	1	Resistance Cable	78	4	M6 x 38mm Hex Screw
15	2	Handle Endcap	47	1	Idler Wheel	79	4	Seat Carriage Bushing
16	1	Upper Wire Harness	48	1	Idler Washer	80	4	M8 x 31mm Button Screw
17	1	Spring	49	1	Idler Arm	81	1	Magnet
18	4	M8 Flat Washer	50	1	M10 x 25mm Bolt	82	1	Bumper Axle
19	1	Pulley	51	3	M6 Nut	83	1	Clamp
20	5	M4 x 48mm Screw	52	3	M4 x 64mm Button Screw	84	2	Bumper
21	21	M4 x 16mm Screw	53	1	M6 x 38mm Bolt	85	2	M6 x 16mm Button Screw
22	1	Thrust Washer	54	2	Flywheel Bearing	86	2	Pulse Wire
23	1	Seat Rail Endcap	55	1	Console Plate	87	1	Control Board
24	1	Left Rear Side Shield	56	8	M8 Nylon Locknut	88	4	M8 x 14mm Button Screw
25	6	M6 Washer	57	1	M8.5 Washer	89	3	5/16" x 14mm Screw
26	1	Right Rear Side Shield	58	1	Adjustment Bracket	90	4	M4 x 16mm Screw
27	12	M8 x 25mm Button Screw	59	1	Eyebolt	#	1	User's Manual
28	4	M4 Washer	60	4	Offset			
29	4	M6 x 16mm Hex Screw	61	1	Flywheel			
30	1	Resistance Motor	62	2	Idler Bearing			
31	2	Leveling Pad	63	2	M10 x 82mm Carriage Bolt			
32	3	Crank Bearing	64	2	Rear Stabilizer Endcap			

Note: "#" indicates a non-illustrated part.  
 Specifications are subject to change without notice. See the back cover of this manual for information about ordering replacement parts.

# EXPLODED DRAWING—MODEL NO. RBEX39010

R1101A

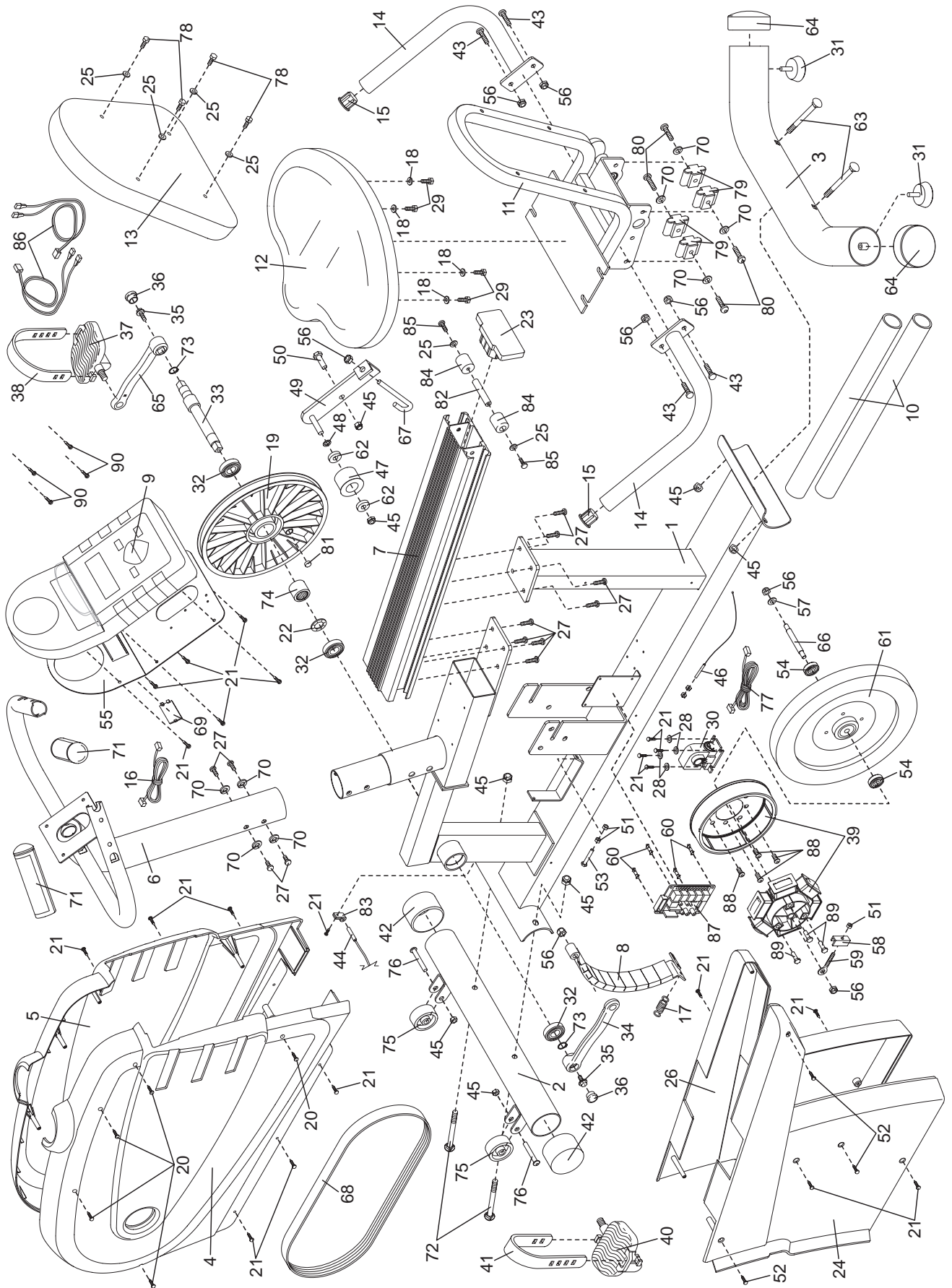

# HOW TO ORDER REPLACEMENT PARTS

To order replacement parts, call our Customer Service Department toll-free at 1-800-999-3756, Monday through Friday, 6 a.m. until 6 p.m. Mountain Time (excluding holidays). To help us assist you, please be prepared to give the following information:

- the MODEL NUMBER of the product (RBEX39010)
- the NAME of the product (REEBOK® CYC12 exercise cycle)
- the SERIAL NUMBER of the product (see the front cover of this manual)
- the KEY NUMBER and DESCRIPTION of the part(s) (see the PART LIST on page 14).

REEBOK and the Vector Logo  are registered trademarks and service marks of Reebok. This product is manufactured and distributed under license from Reebok International.

## LIMITED WARRANTY

ICON Health & Fitness, Inc. (ICON), warrants this product to be free from defects in workmanship and material, under normal use and service conditions, for a period of ninety (90) days from the date of purchase. This warranty extends only to the original purchaser. ICON's obligation under this warranty is limited to replacing or repairing, at ICON's option, the product through one of its authorized service centers. All repairs for which warranty claims are made must be pre-authorized by ICON. This warranty does not extend to any product or damage to a product caused by or attributable to freight damage, abuse, misuse, improper or abnormal usage or repairs not provided by an ICON authorized service center, products used for commercial or rental purposes, or products used as store display models. No other warranty beyond that specifically set forth above is authorized by ICON.

ICON is not responsible or liable for indirect, special or consequential damages arising out of or in connection with the use or performance of the product or damages with respect to any economic loss, loss of property, loss of revenues or profits, loss of enjoyment or use, costs of removal, installation or other consequential damages of whatsoever nature. Some states do not allow the exclusion or limitation of incidental or consequential damages. Accordingly, the above limitation may not apply to you.

The warranty extended hereunder is in lieu of any and all other warranties and any implied warranties of merchantability or fitness for a particular purpose is limited in its scope and duration to the terms set forth herein. Some states do not allow limitations on how long an implied warranty lasts. Accordingly, the above limitation may not apply to you.

This warranty gives you specific legal rights. You may also have other rights which vary from state to state.

**ICON HEALTH & FITNESS, INC., 1500 S. 1000 W., LOGAN, UT 84321-9813**