

AMP-12

NU-VU® Roll-In Rack Proofer

Project _____

Item _____

Quantity _____



SIZE:

AMP-12 - 77-1/2" High, 32" Wide, 37-3/8" Deep
1969 mm High, 813 mm Wide, 949 mm Deep

NU-VU's AMP-12 roll-in rack proofer features heavy-duty stainless steel construction, with solid doors. These units also feature the AutoMist humidity system. While these units do not come standard with a roll-in rack, they are available as an accessory item.

CONSTRUCTION:

- Stainless steel construction
- Fully insulated
- Control panel accessible through front and top of unit
- Heating elements accessible inside of cabinet and through top

CONTROLS:

- Solid state controls
- Indicator light for thermostat
- Separate heat and humidity controls

LABORATORY CERTIFICATION AND APPROVAL



NU-VU® AMP-12 Roll-In Rack Proofer

STANDARD FEATURES:

- Stainless steel construction
- Solid door
- Solid state controls
- AutoMist humidity system
- Magnetic door handle

OPTIONAL FEATURES:

- Stainless steel roll-in rack (20-1115)



NU-VU® Food Service Systems

www.nu-vu.com
5600 13th Street
Menominee, MI 49858

1-800-338-9886 Toll Free
1-906-863-4401 Phone
1-906-863-5889 Fax



Approval / Stamp

AMP-12 Roll-In Rack Proofer

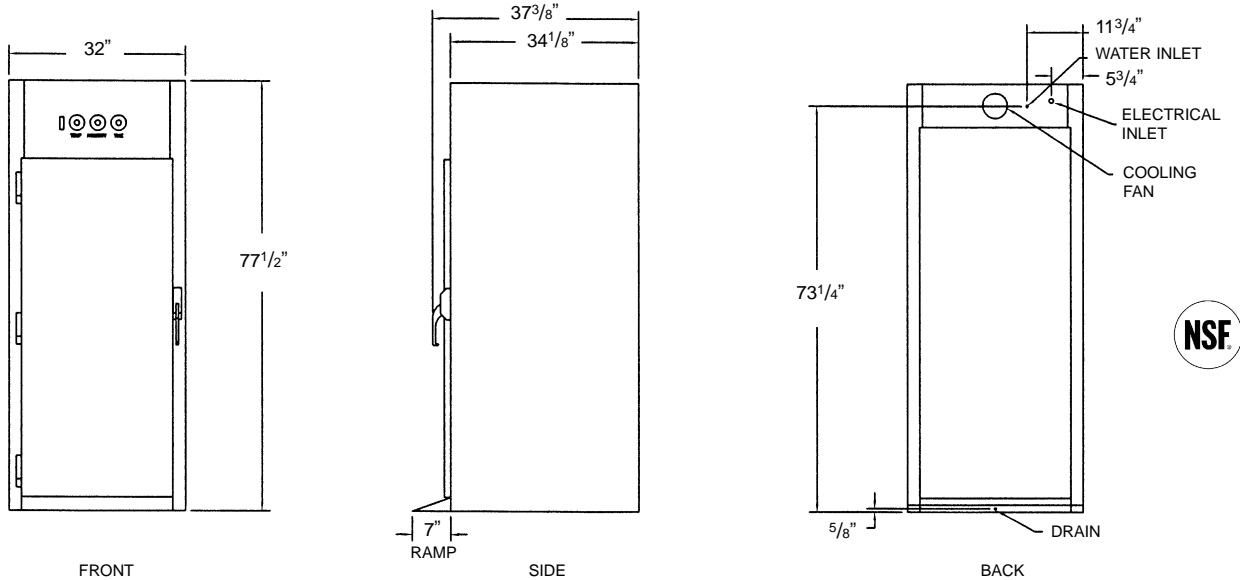

NU-VU® AMP-12 Roll-In Rack Proofer

SPECIFICATIONS:

ELECTRICAL:

SERVICE CONNECTIONS:

- Unit is shipped from factory to be hard wired on site. Single phase uses three-wire system. Three phase uses four-wire system.
- 208 or 240-Volt single or three phase is standard. Please specify at time of order.
- A 1/4" waterline is required. A water softening system should be used to minimize build-up.

ELECTRICAL:

Amp Draw	208/1	208/3	240/1	240/3
	13	10	12	9

INSTALLATION:

Allow four inches on each side and back of unit for ventilation of oven.

CAPACITY:

	18"x26" Sheet Pans	13"x18" Sheet Pans	Spacing
Proofer	12	24	n/a

DIMENSIONS:

	Height	Width	Depth
Exterior	77-1/2"	32"	37-3/8"
Interior	63-1/2"	24"	32"

DOOR SWING: Proofer - 30" (762 mm)

PACKING SIZE:

83" High, 40" Wide, 40" Deep
(2108 mm High, 1016 mm Wide, 1016 mm Deep)

SHIPPING WEIGHT:

600 Pounds (272 Kg), FOB Menominee, MI 49858

LISTINGS:

The AMP-12 has NSF and C-ETL-US listings.

