

Hotpoint Service and Spares

FOR SERVICE: If you have a problem with your appliance ring your local Service Office.
FOR SPARES and ACCESSORIES: To purchase spares and accessories send your Accessories Order Form to your Spares Centre. If the accessory or spare part you want is not on the form, contact your Spares Centre for prices and availability.
 Please address all correspondence to Hotpoint Spares Centre or Hotpoint Service Office as applicable.

Service Offices and Spares Centres are open between 8.00am-5.00pm Monday to Friday, except on Public Holidays. 8.30am-12.30pm on Saturdays.

- Service Office and Spares Centre
- Service Office only

EAST

● ESSEX:

Industrial Buildings, Beehive Lane, Chemsford, CM2 9TF.
 Post Codes RM 8 (6) Tel: (0245) 462433

Remainer of Essex Tel: (0245) 269331

Chula Road, PE2 9JB. Tel: (0753) 64741

Spares Administration Dept. Tel: (0733) 556520

LONDON

■ WEMBLEY:

69 East Lane, HA9 7PD. Tel: 081-904 4399

S. Hains and Middlesex. Tel: 081-908 4722

Post Codes N, NW, E, EC. Tel: 081-908 4722

Post Codes W, WC, SE, SW Tel: 081-908 2511

Tel: 081-904 0201

MIDLANDS

● BIRMINGHAM:

Westgate, Aldridge, W Midlands, WS9 8UX.
 Post Codes B Tel: (0922) 743374

All other Post Codes Tel: (0922) 743376

Tel: (0922) 743377

■ NOTTINGHAM:

Ashting Street, NG2 3JB. For Spares Tel: (0602) 869387

Tel: (0602) 862431/864322. For Spares Tel: (0602) 869387

West Ave, Nelson Estate, Tulse, S17 7TN. Tel: (0782) 774511

NORTH EAST

● WASHINGTON:

8 Bede House, Tower Road, Glover East, District 11, NE37 2SH.
 Tel: 091-477 2500/419 3535

Sandbeck Lane, LS22 4TW.

Tel: (0937) 581261/581444. For Spares Tel: (0937) 581221

NORTH WEST

● KENDAL:

Munford House, 26 Highgate, LA9 4SX. Tel: (0539) 724483

44/46 Station Road, Heaton Mersey, Stockport, SK4 3DT.

Manchester North Tel: 061-432 0513

Manchester South Tel: 061-442 8677

Tel: 061-432 0255

● NETHERTON:

7 Bridle Way, Messydale. Tel: 051-355 2342/524 2339

SCOTLAND

● ABERDEEN:

Holbeck House, 68 Carden Place, AB1 1UL. Tel: (0224) 642283

35 West Bowling Green Street, Leith, EH6 5NX. Tel: 031-554 1431

West Lodge Road, Blythwood Estate, PA4 9EN.

Tel: 041-586 6241. For Spares Tel: 041-586 5611

SOUTH

■ KENT:

Larkfield Trading Est., New Hythe Lane, Larkfield, ME20 6SW.
 CT DA ME & TN Kent Post Codes Tel: (0822) 716571

CR K1, RH, SM Surrey & BB Kent Post Codes (0822) 790707

GU Post Codes in Surrey Tel Southampton (0703) 867374

Tel: (0822) 716631

SOUTHAMPTON:

Unit R, S Hammsline Ind Park, Salisbury Rd, Totton, SO40 3SA.
 Tel: (0703) 861981/667374. For Spares Tel: (0703) 867933

1 Kingswood, North St, Hantsham, BU27 10D. Tel: (0323) 842733

69 Mulvey Plain, P 4 6JH. Tel: (0752) 262631

WALES

● NORTH:

Conwy Rd, Llandudno Junction, LL31 9PE. Tel: (0492) 573636

18 Western Ave, Bridgend Ind. Estate, Bridgend, CF31 3SL.

Post Codes CF, SA & SY23-25 Tel: (0656) 664121

Post Codes BS, GL (ind 59), HR, SY15-18, LD1-8, NP. Tel: (0656) 655554

Tel: (0656) 786111

For Spares

IRELAND	
● NORTHERN:	256 Ormeau Road, Belfast, BT7 2FZ. Tel: (0232) 647111
■ EIRE:	49 Airways Ind. Estate, Dublin 17. Tel: Dublin 426008 Tel: Dublin 426536
For Service	
For Spares	

CHANNEL ISLANDS – Service provided by Agents. Normal Guarantees apply and all Service Schemes are available	
JERSEY:	19 Don Street, St. Helier. Tel: (0534) 21625 Clos D'Ormes, Pontie. St Clements. Tel: (0534) 54808
GUERNSEY & SARK:	Valois Stores, Grande Rue, St Martins, Guernsey. Tel: (0461) 38422
or	Barras Lane, Vale. Tel: (0481) 51610
ALDERNEY:	32 High Street, Tel: (0481) 822686

ISLE OF MAN – Service provided by Agents. Normal Guarantees apply and all Service Schemes are available	
from	5 Dunningd St., Douglas. Tel: (0624) 673233
or	Tromode Works, Crombourne Village, Douglas. Tel: (0624) 676066
or	17 Ridgeway Street, Douglas. Tel: (0624) 25817/25848

SHETLAND, ORKNEY & WESTERN ISLES – Service provided by Agents. Normal Guarantees apply, but Service Schemes are NOT available.	
SHETLAND: Fort Road, Lerwick Tel: (0896) 2557	
ORKNEYS: Hastone Ind. Estate, Kirkwall. Tel: (0856) 5457	
WESTERN ISLES: 27 Bayhead Street, Stornoway, Isle of Lewis Tel: (0851) 3387	
OTHER ISLANDS: Local Hydro Electric Shops. EXCEPT ARRAN, BUTE & SKYE – Which are covered by Hotpoint.	

In accordance with its policy of progressive product design, the Company reserves the right to alter specifications.

Hotpoint Ltd, Peterborough, PE2 9UB, England

229/271/733

Printed in England C94

HOTPOINT HANDBOOK

FREEZER FRIDGE

MODEL 8642

Hotpoint®

Your new Hotpoint Freezer Fridge

Using your new freezer fridge is very simple. Nevertheless, for your own safety and to get the best results it is important that you read right through this handbook **before** using your freezer fridge for the first time. Do not load the freezer compartment immediately the freezer fridge is switched on, but wait until the correct storage temperature has been reached (see page 9).

ELECTRICAL REQUIREMENTS

We recommend that this appliance is connected to the mains supply via a suitable switched socket in a readily accessible position.

All Hotpoint appliances come complete with a fitted plug. The plug on your freezer fridge has a 13A fuse. If the plug does not fit your sockets, a new plug can be fitted. Cut off the old plug and throw it away, do not insert it into a socket elsewhere in the house as this could cause a shock hazard.

WARNING: THIS APPLIANCE MUST BE EARTHED.

IMPORTANT: Fitting a Different Plug:

The wires in the mains lead are coloured in accordance with the following code:

Green and Yellow – Earth
Blue – Neutral
Brown – Live

If you fit your own plug the colours of these wires may not correspond with the identifying marks on the plug terminals. This is what you have to do:

1. Connect the green and yellow (Earth) wire to the terminal in the plug marked 'E' or with the symbol \perp , or coloured green or green and yellow.
2. Connect the blue (Neutral) wire to the terminal in the plug marked 'N' or coloured black.
3. Connect the brown (Live) wire to the terminal marked 'L' or coloured red.

With alternative plugs a 5A fuse must be fitted either in the plug or adaptor or in the main fuse box. In the event of replacing a fuse in the plug supplied, a 13A ASTA approved fuse to BS1362 must be fitted.

If the plug is the moulded on type the fuse cover must be refitted when changing the fuse. In the event of losing the fuse cover the plug must **not** be used until a replacement fuse cover has been obtained and fitted. A new fuse cover can be obtained from your nearest Hotpoint Spares Centre or local Electricity Company. The colour of the correct replacement fuse cover is that of the coloured marks or insert in the base of the plug.

Mains Lead Replacement

If the mains lead on this appliance needs replacing at any time, it must be replaced by a special lead which is obtainable from your nearest Hotpoint Service Office (see back page). A charge will be made for the replacement of the mains lead if you have damaged the lead or require a longer lead.

WARNING: HOW TO AVOID ACCIDENTS TO CHILDREN. WHEN DISCARDING AN OLD FRIDGE OR FREEZER BE CERTAIN TO MAKE THE LOCK UNSABLE. IF POSSIBLE, REMOVE THE DOORS AND DISCARD SEPARATELY. DO NOT ATTEMPT TO STAND ON TOP OF YOUR APPLIANCE. IT IS NOT DESIGNED FOR SUCH USE AND YOU COULD INJURE YOURSELF OR DAMAGE THE APPLIANCE BY SUCH ABUSE. CHILDREN SHOULD NOT BE ALLOWED TO PLAY WITH THE APPLIANCE OR TAMPER WITH THE CONTROLS.

Hotpoint Service Cover

Satisfaction Guaranteed or Your Money Back

Hotpoint gives you a unique 'Satisfaction Guaranteed' promise – valid for ninety days after you have purchased your Hotpoint product. If there is a problem with your Hotpoint appliance just call your Hotpoint Service Office. If necessary we will arrange for an engineer to call. If the problem is not resolved by us under this Guarantee, Hotpoint will replace your appliance or, if you prefer, give you your money back. This Guarantee is additional and subject to the terms of Hotpoint's Five Year Parts Guarantee.

Hotpoint's Free Five Year Guarantee

From the moment your appliance is delivered, Hotpoint guarantees it for **FIVE YEARS**.

- In the Five Years all replacement parts are **FREE** provided they are fitted by our own Service Engineer. During the first year our Engineer's time and labour is also free. Our Guarantee also covers loss of food in our Refrigeration and Freezer products up to £250 during the first year.
- After the first year we will charge for our Engineer's time and labour. We do however, operate a range of Service Plans (see opposite) which for an annual payment enables you to cover any repair costs which may be necessary.
- All our service repairs are guaranteed for twelve months in respect of our labour and any parts fitted.
- The appliance must be used in the United Kingdom and must not be tampered with or taken apart by anyone other than our own Service Engineer.
- You may, however, buy parts which can be safely fitted without specialist knowledge or equipment. The correct fitting of such parts, provided they are genuine Hotpoint spares, will not affect your Guarantee. Parts are available from our main Hotpoint Spares Centres (see back page).
- Our Guarantee does not cover the cost of any repair which is needed because of power cuts, accidents or misuse. Nor does it cover the cost of any visit to advise you on the use of the appliance. Please read the instruction book thoroughly.

- If at any time during the Guarantee period we are unable to repair your appliance, we will refund any repair costs paid to us in the previous twelve months. We will also offer you a new appliance at a reduced charge instead of a repair.
- Our Guarantee is in addition to and does not affect your legal rights.
- Should you need independent advice on your consumer rights, help is available from your Consumer Advice Centre, Law Centre, Trading Standards Department and Citizens Advice Bureau.

- All Hotpoint servicing is done by our own Service Organisation located throughout the United Kingdom and Southern Ireland. It will be happy to deal with any problems.

Hotpoint's Service Care

Whether you have just one or a number of Hotpoint appliances in your Kitchen Hotpoint has a range of Service Schemes to give you complete peace of mind.

Service Cover

A single payment covers you for all repairs during the period of cover, which can be from 1 to 4 years. There is also an option of Service Cover with Maintenance at an additional cost. This includes an annual Electrical and Safety check and replacement of any parts as necessary. For 1 year contracts this takes place towards the end of the contract period.

Kitchen Cover

An annual payment covers you for all repairs for all your Hotpoint appliances which are less than ten years old. It also covers the cost of loss of food up to £250 in our refrigeration and freezer products. There is also an option of Kitchen Cover with Maintenance at an additional cost. Any additional Hotpoint appliances purchased after you have joined Hotpoint Kitchen Cover will automatically be included during the annual period of cover without further charge.

Appliance Registration

To ensure that you have the opportunity to benefit from any of the above Service Schemes you should complete and return immediately the Appliance Registration Form supplied with your appliance. Full details and costs of our Service Schemes together with an application form will be sent to you at the end of the first year of the guarantee.

Annual Safety/Maintenance Checks

Hotpoint strongly recommends that all its appliances are regularly checked for electrical and mechanical safety whether or not they are covered by a Service Plan.

Proof of Purchase

For future reference please attach your purchase receipt to this booklet and keep it in a safe place.

Spares and Accessories

Spares and accessories can be ordered from your local Hotpoint Spares Centre (listed on the back page), using the order form enclosed.

NOTE: Our Engineer will use every effort to avoid damage to floor coverings and adjacent units when carrying out repairs/service work but in locations where the Engineer advises you that it will be impossible to move the appliance without risk of damage, he will only proceed with your approval that no liability is accepted.

Contents

THIS BOOK COVERS MODEL 8642

	Page
Get to know your Freezer Fridge	4
Installing your Freezer Fridge	5-6
Where to put your Freezer Fridge Fitting decor panels to match your kitchen units	
Getting your Freezer Fridge ready for use	7
Starting and Running In	
The Controls	8
Controlling the temperature Economy Switch	
Storing Food	9-12
Storing food in the fridge compartment Storing frozen food in the freezer compartment Freezing fresh foods – maximum freezing loads and how to freeze them Do's and Don'ts	
Caring for your Freezer Fridge	13-14
Defrosting Cleaning Going Away Replacing the interior light	
If your Freezer Fridge won't work	15-18
Repositioning the door hinges Hotpoint Service Cover	
Hotpoint Service Offices and Spares Centres	Back Page

Retention of the Instruction Book

This Instruction Book must be kept handy for reference as it contains important details on the safe and proper use of the appliance.

If you sell or pass the appliance to someone else, or move house and leave it behind, make sure this Book is also provided so the new owner can become familiar with the appliance and safety warnings.

If the Book is lost or damaged a copy may be obtained from Hotpoint Ltd, Celta Road, Peterborough, PE2 9JB.

Get to know your Freezer Fridge

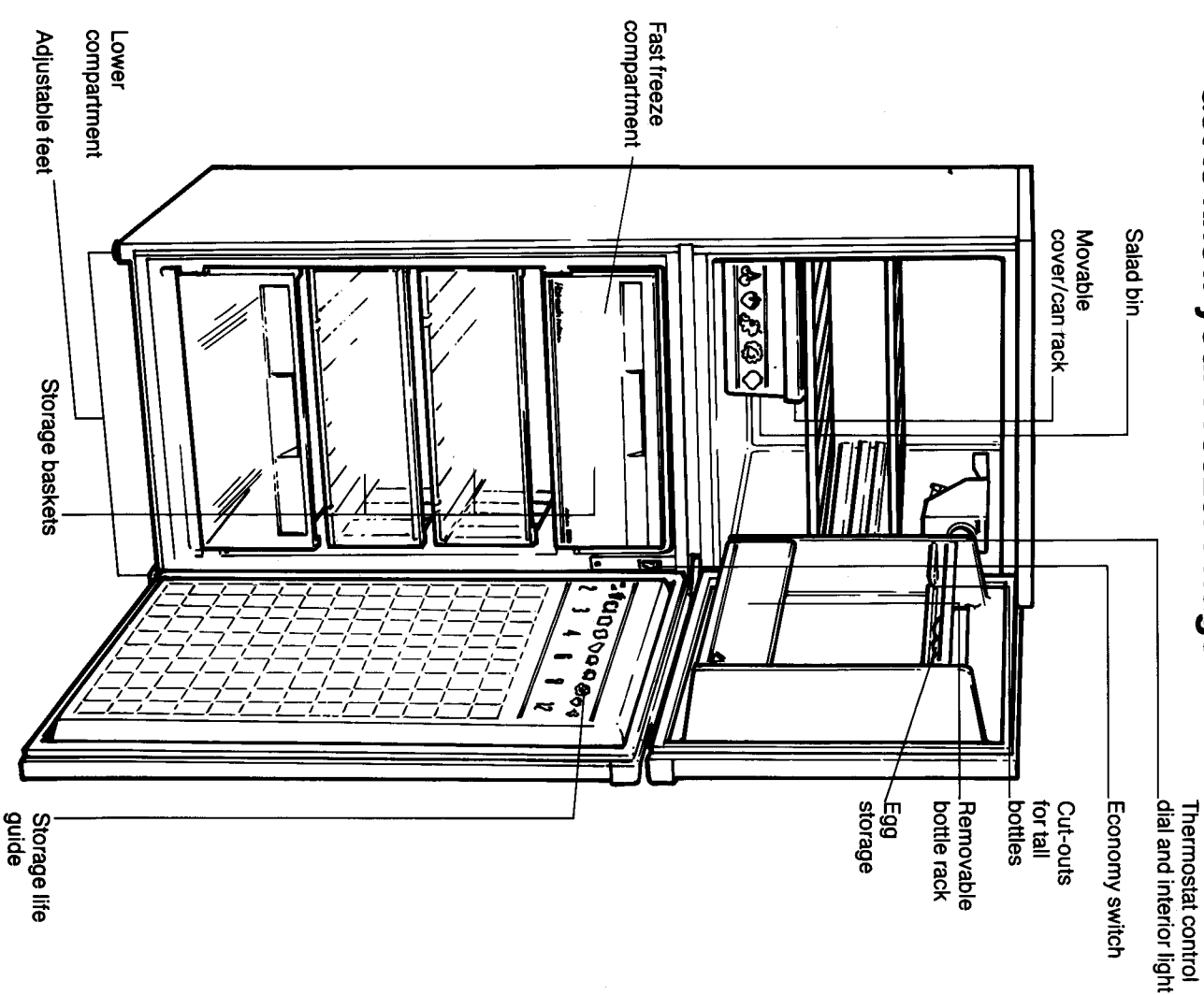

WARNING: CHILDREN SHOULD NOT BE ALLOWED TO PLAY WITH THE APPLIANCE OR TAMPER WITH THE CONTROLS.

18. Using the two fixing screws, secure the bottom hinge to the cabinet.
 19. Replace the adjustable front feet, setting them 36mm from the bottom of the cabinet to the bottom of the foot.
 20. Carefully stand your freezer fridge upright (you may need assistance for this) in the required location. Adjust the front feet until all four feet are in firm contact with the floor and the freezer fridge does not rock. (**See Installing Your Freezer Fridge**).
 21. Check the doors open and close freely. Ensure door seal is seated evenly around the cabinet.
 22. Finally put back all the loose items/fitings.
 23. The freezer fridge must be stood upright for at least 15 minutes before being switched on.
- NOTE:** If difficulties are encountered, contact your local Service Office.

Repositioning the door hinges

Just follow the step by step instructions below:

Tools Required: A 7mm/8mm A/F Spanner or a No. 2 Pozidriv.

1. Remove all loose items/fittings from inside the freezer fridge.
2. Carefully lay the freezer fridge on its back (you may need a second person to support the freezer fridge). **Take care to avoid damage to the pipework by keeping it clear of the floor or by laying it on some protective material (eg. its original packaging).**
3. Unscrew and remove the two front feet.
4. Unscrew and remove the bottom hinge. Ensure any spacing washers fitted, and the fixing screws, are kept with the hinge.
5. Remove the lower door by gently pulling it downwards. Stand the door carefully to one side.
6. Unscrew and remove the centre hinge, ensuring any spacing washers fitted, are kept with the hinge and screws.
7. Remove the top door and stand it carefully to one side.
8. Unscrew and remove the top hinge, then replace the screws.
9. Remove the two hinge fixing screws on the top left hand side and use them to refit the top hinge.
10. Remove the plate from the front/bottom left hand side of the cabinet and refit on the right hand side where the bottom hinge was.
11. Prise off the screw covers on the centre left hand side (using a thin blunt instrument). Remove the screws and cup washers and refit on the right hand side.
12. **Preparing the door for change over.**
 - a) Remove the top and bottom hinge

bushes and the blanking plug, with a thin blunt instrument taking care not to mark the handle. Reposition on the opposite side.

b) Unscrew and remove the handle insert and replace the screws. Refit the insert with the screws from the left hand side.

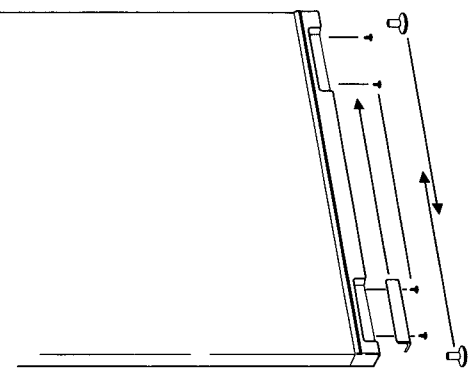

13. Refit the top door, sliding it upwards, locating the top hinge pin in the door hinge bush.
14. Fit the centre hinge (and spacing washers) into the bottom hinge bush of the top door, positioning the door so that it fits evenly with the cabinet sides.
15. Using the two fixing screws secure the centre hinge to the cabinet.
16. Refit the bottom door sliding it upwards locating the centre hinge in the door hinge bush.
17. Fit the bottom hinge (and spacing washers) into the bottom hinge bush, adjusting the door so that it fits evenly with the cabinet sides.

Installing your Freezer Fridge

Where to put your Freezer Fridge

Your Freezer Fridge should be placed where it is easy to use, alongside a work surface is often a good position. Avoid putting it near anything which gives off heat, a cooker or radiator for example. In such a position your Freezer Fridge will have to work harder and will cost more to run and may also be damaged by the heat.

Do not put your Freezer Fridge in a very cold room where the temperature goes below 6°C (43°F) for prolonged periods. In such a position the freezer compartment will run warmer and the storage time of frozen food may be reduced.

Once you have decided on the most suitable place, fit the two wall spacers supplied to the top of the condenser using the correct slot in the spacer for your particular type of condenser – your Freezer Fridge is fitted with one of two alternative condensers (a) or (b) as shown below. Push the Freezer Fridge back until the spacers are against the wall. This automatically ensures adequate air circulation at the back of the Freezer Fridge.

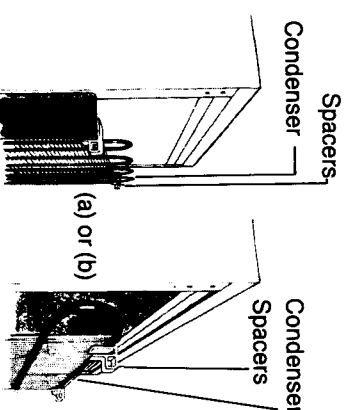

If your Freezer Fridge is placed underneath any wall cupboards, make sure that there is a gap of at least 100 mm (4") between the top of the Freezer Fridge and the underside of the cupboards.

Finally, make sure your Freezer Fridge is standing correctly by carefully adjusting the two front feet by turning them clockwise or anti-clockwise, until all four feet are in firm contact with the floor. Correct adjustment avoids excessive vibration and noise.



A Wheel Kit, Part No. 8031, for fitting to the back of your Freezer Fridge, is available from your retailer or nearest Hotpoint Spares Centre using the Accessories Order Form supplied.

Fitting decor panels to match your

Kitchen units

For that fully co-ordinated kitchen look it is possible to fit matching decor panels to your Freezer Fridge. Special trim kits are available from Hotpoint that attach to the edges of the appliance doors and enable decor panels, up to 4 mm (1/8") thick, to be fitted. Decor panels are available from most kitchen suppliers.

Each door requires a separate trim kit:

Top door requires trim kit Part No. 8003 (Brown) or Part No. 8006 (White).

Bottom door requires trim kit Part No. 8001 (Brown) or Part No. 8004 (White). These are available from your retailer or nearest Hotpoint Spares Centre (see back page) using the Accessories Order Form supplied with your Freezer Fridge.

If your Fridge Freezer won't work . . .

don't panic

Just run through these quick checks before calling your nearest Hotpoint Service Office:

1. Check that the plug is firmly in the wall outlet socket and that the power supply is on.
 2. Check the power supply to the socket by plugging in another appliance.
 3. If the other appliance works, check the fuse in the Freezer Fridge plug.
 4. If you have changed the plug, check the wiring (see page 2).
 5. If there is excessive noise or vibration, check that all four feet are firmly in contact with the ground (see page 5).
 6. If water appears down the inside back of the fridge compartment, check that the gutter drain hole has not become blocked and that there is nothing touching the cooling plate. (**NB** Water droplets on the cooling plate are quite normal.)
 7. If water droplets appear on the outside of the cabinet, check that you have the Economy switch set on 'H' (see page 10).
 8. You may find the freezer compartment door difficult to open just after you have used it. This is due to a pressure difference which will soon equalise. Wait a few minutes then open the door.
 9. If the interior light fails to work, refer to the section adjacent (page 16) for further instructions.
- If, after following all these instructions, you are still having problems, contact your nearest Hotpoint Service Office (or local importer if outside the United Kingdom). The telephone number is shown on the back page.

When you contact us we need to know:

1. Your name, address and post code.
 2. Your telephone number.
 3. Clear and concise details of the fault.
 4. The model number (8642), serial number (found on the label on the underside of the front top of the appliance), and colour.
 5. When it was purchased. Please put the date here
.....
 6. If you have subscribed to the Hotpoint Service Cover Plan (see opposite page).
- Make sure you have all these details before you call.

Spare Parts

Please remember your new appliance is a complex piece of equipment.

'DIY' repairs or unqualified and untrained service people may put you in danger, could damage the appliance and might mean you lose cover under Hotpoint's Parts Guarantee.

If you do experience a problem with the appliance don't take risks; call in Hotpoint's own Service Engineer. Our spare parts are designed exclusively to fit only Hotpoint appliances. Do not use them for any other purpose as you may create a safety hazard.

7. After defrosting remove the bowls and dry the interior thoroughly.
8. Replace the mains plug and switch on. Unwrap the frozen food and replace. Close the door.
9. Job done!

Cleaning your Freezer Fridge

It is a good idea to clean the inside of your Freezer Fridge after defrosting. **Always switch off and pull out the mains plug first.** Wipe out the inside of the Freezer Fridge using a clean cloth wrung out in either a solution of one teaspoonful of bicarbonate of soda to one pint of water or Milton diluted according to the manufacturer's instructions. The complete interior including the door, and removable parts, should be washed. The bottle and egg racks and ice cube tray may be washed in a dishwasher, but only if positioned on the top rack and on a low temperature programme. **Never** use any household cleaner or detergent, abrasive powders or wax polish. These not only damage the surfaces, but also leave a smell in the Freezer Fridge. Make sure that no particles of food are left in the gutter in the fridge compartment. Before you refill the Freezer Fridge ensure it is thoroughly dry.

Clean the outside of the Freezer Fridge, **but not the door seal**, with a damp cloth, using a small amount of detergent, followed by a wipe down with a clean cloth. **Do not** use an abrasive powder. **The rubber door seal must be cleaned with soap and water only as detergent will damage it.**

Finally, the compressor and condenser at the back of the Freezer Fridge can be carefully cleaned. Use a brush or vacuum cleaner to remove

any dust. **Always** check that the Freezer Fridge is disconnected from the mains when doing this. Remember to replace the mains plug and switch on after cleaning your Freezer Fridge.

Going away

If you expect to be away for any length of time and don't want to use your Freezer Fridge, switch off at the power point and pull out the plug. Remove all food and follow the defrosting instructions (see page 15). After defrosting dry out the interior. Always leave the doors ajar to prevent the accumulation of odours.

How to replace the interior light

Should the light fail to work, **switch off and pull out the mains plug**, then ensure the bulb is screwed securely into the bulb holder.

Replace the plug and switch on. If the light still fails to work, do not worry, it will not affect the working of your Freezer Fridge. Obtain a replacement SES 15 Watt bulb from a local electrical retailer or your nearest Hotpoint Spares Centre and then fit it as follows:

1. **Switch off and pull out the mains plug.**
2. Remove the wire shelves to make access easier.
3. Slacken off the lamp guard, undoing the pozidrive retaining screw by one turn.
4. Unclip and remove the lamp guard.
5. Unscrew the old bulb and fit the new one.
6. Refit the lamp guard, ensuring that the two legs opposite the retaining screw fit into the holes.
7. Retighten the retaining screw.
8. Replace the plug and switch on.

Getting your Freezer Fridge ready for use

Before using your Freezer Fridge for the first time the interior, including the door, and all removable parts should be wiped out. Use a damp cloth wrung out in either a solution of one teaspoonful of bicarbonate of soda to one pint of water or Milton diluted according to the manufacturer's instructions.

WARNING: NEVER USE ANY HOUSEHOLD CLEANER OR DETERGENT, ABRASIVE POWDERS OR WAX POLISH.

THESE NOT ONLY DAMAGE THE SURFACES, THEY ALSO LEAVE A SMELL IN THE FREEZER FRIDGE.

Final check

Before you start using the Freezer Fridge, check that

1. it is thoroughly dry inside,
2. air can circulate freely,
3. the feet have been adjusted, i.e. all four are firmly on the ground.

Starting

Insert the plug into the socket outlet and switch on the electricity supply. Open the fridge compartment door and the light will come on. There is a control dial on the right hand side of the interior. Turning the dial clockwise from 'O' (off) will start the Freezer Fridge working. You will hear a noise as the compressor starts up. A control setting of 4-5 is usually suitable, see below.

If you are going to store already frozen food allow at least two hours for the freezer compartment to reach the necessary storage temperature before you put in the frozen food.

If you are going to freeze fresh food, **wait at least three hours** before putting in your fresh food to be frozen. Do not put more than 10kg

(22 lb) of fresh food to be frozen in the Freezer compartment (see page 12).

Running-in the compressor

The liquid and gases sealed within the refrigeration system may give rise to noise, whether the compressor is running or not. This is quite normal.

Your Freezer Fridge is operated by a compressor which switches on and off in order to maintain the Freezer Fridge's temperature. The compressor is a precision piece of machinery and, like a car engine, requires a running-in period of up to 2 months. During this time the compressor has to work a little harder and this may result in more noise than usual.

Note: Your Freezer Fridge is designed only for domestic purposes; for the storage of food and drink and for the freezing and storage of food.

The Controls

Controlling the Temperature

The temperature inside your refrigerator should be 5°C or less, though some sections such as the Salad Crisper will be warmer. Frequent door openings cause higher temperatures inside.

We recommend using a thermometer to check the temperature, it should be left overnight on the centre of the middle shelf and read immediately the door is initially opened the following morning. If the temperature reading is not between 0°C and 5°C then the control dial should be adjusted (see below).

A fridge/freezer thermometer Part No. 8058 is available to ensure that you maintain your appliance at the correct temperature. This can be ordered from your local Hotpoint Spares Centre (see back page) using the order form enclosed.

WARNING: DO NOT USE A

MERCURY FILLED THERMOMETER.

The control dial, on the right-hand side of the fridge compartment interior, controls the temperature inside the fridge compartment and maintains the freezer compartment at the correct temperature. It is marked 'O' (off), 1, 2, 3 . . . 9.

Which setting is selected will depend on where the Freezer Fridge is located, how often you open the door and the room temperature.

A control setting of 4-5 is usually suitable, but if you find the interior of the fridge compartment is too warm turn the control clockwise to a colder setting (higher number). Similarly, if you find the interior is too cold, turn the control anti-clockwise to a

warmer setting (lower number). With a suitable fridge compartment temperature the freezer compartment will automatically be maintained at the correct temperature necessary for ******** frozen food storage (see Storing compartment – page 12).

In the summer months, or in conditions giving high temperatures around the Freezer Fridge, the compressor has to work harder and run for longer periods. This is quite normal. Conversely, during cold weather the compressor will run for much shorter periods.

Economy Switch

Press 'E' (Economy position) for normal conditions.

If the room is cold or humid or if freezing fresh food, water droplets may form on the outside of the Freezer Fridge. When this happens press 'H' (Humid position). A low energy heater will come on and the water droplets will disappear. When conditions return to normal reset the switch to 'E'.

Note: When the switch is set on 'H' the outside front edges of the Freezer Fridge may feel warm. This is normal.

Caring for your Freezer Fridge

Defrosting

The fridge compartment

The fridge compartment will **automatically** defrost itself and the defrost water will drain out through the hole in the gutter and into a special container where it evaporates. Water droplets will form on the cooling plate during the defrost periods and will freeze on the plate afterwards. If your kitchen becomes **exceptionally** warm the cooling plate may not defrost regularly. Do not worry. Periodic defrosting will begin again when conditions return to normal.

Do make sure that the gutter is always kept clear and that stored food does not come into contact with the cooling plate.

The freezer compartment

Frost forms on the cold surfaces from the moisture in the air and improperly wrapped food. The frost will build up first on the roof of the fast freeze compartment, towards the front, this is normal.

From time to time remove the frost from this, and other frosted surfaces, using the plastic scraper provided.

Never use sharp metal tools to remove the frost – they will damage your freezer beyond repair.

Periodically you will need to fully defrost your freezer, how often will be dependent on usage. Try to defrost when there is little or no food in the freezer compartment.

Defrosting must be carried out as quickly as possible since a rise in the temperature of your frozen food may reduce the recommended storage time. Just follow these steps:

1. **Switch off and pull out the mains plug.**

2. Remove any frozen food. Wrap it in several layers of newspaper or a blanket and put it in the fridge compartment or a cool place. Remove the empty baskets.

3. Remove the freezer and lower compartment doors. This is done by opening the compartment door 45 degrees and gently lifting and pushing the **left hand** corner so that the pin comes up and out of the special hinge. The door can then be removed from the right hand hinge by pulling the door to the left. To replace each door after cleaning: ensure the upper door pins are positioned in front of the hinges. Fit the right hand, bottom door pin into the bottom slot in the right hand hinge. Then pull the left hand bottom pin in through the back slot in the left

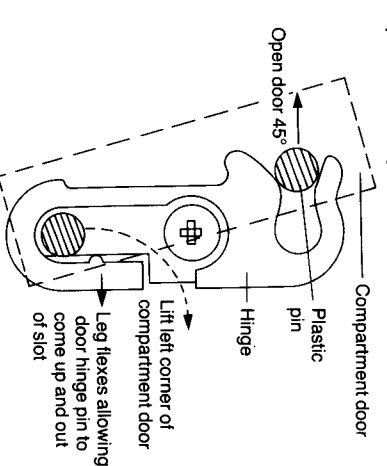

4. Place bowls of hot water (**Do not** use any other heat source) in the fast freeze compartment and lower compartment.
5. As soon as the frost begins to melt use the plastic scraper to remove it.
6. Sponge out the defrost water which collects in the bottom of the freezer.

Storing Food

Storing food in your fridge compartment

You can store most fresh foods in the fridge compartment. Recommended maximum storage times are given in the table below.
Store meat, cooked meats, ham, sausage, milk products in the area

just above the salad drawer; butter, eggs, preserves, cheese, margarines, etc. in the commodity racks on the door; convenience foods, baked items on the top and centre shelves; drinks in the bottle rack; fruit, vegetables, salad items in the salad bins.

		Days
Raw fresh meat	joints, steaks, chops	1
	offal (liver, kidney etc)	1
	minced meat, sausages	1
Cooked meat	cooked meat	1
	made-up dishes and left-overs	1
Poultry	fresh, whole (store giblets separately)	1
	cooked	1
	giblets	1
Fish	raw	1
	cooked	2
Bacon	joints (uncooked)	2-8
	rashers	2-10
	ham (unsmoked)	1-3
Milk	pasteurised and homogenized	1-3
	fresh	2
Cream	fresh	2-10
	yogurt, sour cream	14-28
Butter		21-28
		7-28
Margarine and cooking fats	hard	7-14
	semi hard, blue	7
	cream, cottage	7-28
Eggs	shell	1-3
	hard boiled	2-14
Vegetables		2-14
		1-3
Salad	vegetables	2-14
	prepared	1-3

Don't:- Exceed the maximum freezing loads when freezing fresh food (see page 12).

Don't:- Put hot food into the freezer or even in the fridge compartment. Let it cool down first.

Don't:- Leave the door open for long periods as this will cause excessive ice formation and make the freezer compartment more costly to run.

Don't:- Put liquid-filled bottles or sealed cans containing carbonated liquids (fizzy drinks, etc) into the freezer compartment as they may burst.

Don't:- Try to keep frozen food which has thawed; it should be eaten within 24 hours or cooked and refrozen.

Don't:- Give children lollipops and water ices direct from the freezer compartment. The low temperature may cause 'freezer burns' on their lips.

Don't:- Store poisonous or dangerous substances in the freezer. Your freezer has been designed for the storage of edible foodstuffs only.

Freezer compartment

Do:- Always choose high quality fresh food and be sure it is thoroughly clean before you freeze it.

Do:- Prepare fresh food for freezing in small portions to ensure rapid freezing.

Do:- Remember lean foods last longer than fat foods and salt will reduce storage life.

Do:- Wrap all foods in aluminium foil or freezer quality polythene bags and make sure any air is excluded. Keep the door shut when freezing fresh food.

Do:- Separate food in different baskets for easy identification.

Do:- Wrap frozen food when you buy it and put it into the freezer compartment as soon as possible.

Do:- Empty and refill the ice trays periodically to ensure freshness.

Do:- Store commercially frozen food in accordance with the instructions given on the packets that you buy.

Do:- Defrost the freezer compartment before the ice becomes thick (see page 15).

Do:- Ensure that cooked meat and raw meat are separately packaged.

Do:- Always defrost frozen food thoroughly before cooking unless the instructions on the packet state otherwise.

Do:- Ice cream should be removed from the freezer 15-30 minutes before serving.

Storing frozen food in your freezer compartment

Your freezer compartment carries the ******* symbol which indicates that it is suitable for the long-term storage of commercially-frozen foods and also can be used to freeze and store fresh food.

The freezer compartment will store up to 32kg (70lb) of frozen food. This figure is based on an average density of 0.32kg of mixed food per litre of net storage volume (20lb per cubic foot). In the case of meat it will take appreciably more.

Generally speaking long-term storage means up to 3 months, but this will vary with the nature of the packaged food, so always follow the manufacturer's recommended storage time given on the packet. For storing home frozen fresh food refer to the pictorial guide on the door liner.

If there is a power failure do not open the freezer compartment door. Frozen food should not be affected if the failure lasts for less than 15½ hours. If the failure is longer, then the food should be checked and either eaten immediately or cooked and then refrozen.

Freezing Fresh Foods

Maximum Freezing Loads

You can freeze up to 10kg (22lb) of fresh or cooked food in any 24 hours.

Freezing up to 10kg (22lb)

1. It is not necessary to alter the control setting. If your Freezer Fridge has not been in use follow the instructions given under Starting, page 9.
2. Transfer any frozen food from the fast freeze compartment to the storage baskets or lower

compartment.

3. Press 'H' on the Economy switch to avoid condensation on the outside of the freezer compartment.
4. Put the fresh food into the fast freeze compartment with as much food as possible in contact with the floor.
5. Reset the Economy switch to 'E' when freezing is complete.

Do's and Don'ts

Fridge compartment

- Do:-** Take off any unusable leaves on vegetables and wipe off any soil.
- Do:-** Leave lettuce, cabbage, parsley and cauliflower on the stem.
- Do:-** Wrap cheese firstly in greaseproof paper and then in a polythene bag excluding as much air as possible. For best results take out of the fridge compartment an hour before eating.
- Do:-** Wrap raw meat and poultry loosely in polythene or aluminium foil. This prevents drying.
- Do:-** Wrap fish and offal in polythene bags.
- Do:-** Wrap foods which have a strong odour or can dry out in polythene bags, aluminium foil or place in airtight containers.
- Do:-** Wrap bread well to keep it fresh.
- Do:-** Chill white wines, beer, lager and mineral water before serving.
- Do:-** Make sure the gutter at the back of the fridge compartment is always clear. Remove any particles of food which may collect there.
- Do:-** Keep food for as short a time as possible and adhere to 'sell by' dates.
- Do:-** Store raw meat and poultry below cooked foods and dairy products.
- Do:-** Clean out your salad crisper regularly.
- Do:-** Ensure that cooked meat and raw meat are separately packaged.
- Do:-** Ensure that cooked foods are allowed to cool before storing in the refrigerator.
- Don't:-** Store bananas in the fridge compartment.
- Don't:-** Store melon in the fridge compartment. It can be chilled for short periods as long as it is wrapped to avoid it flavouring other food.
- Don't:-** Wash eggs as this removes their natural protective film. Wipe them instead.
- Don't:-** Use eggs straight from the fridge compartment, especially when making cakes or mayonnaise. Allow them to reach room temperature before use.
- Don't:-** Let defrosting food or food juices drip onto food in your fridge.
- Don't:-** Leave the door open for long periods as this will make the fridge compartment more costly to run.
- Don't:-** Cover the shelves with any protective materials which may obstruct air circulation through them.
- Don't:-** Let anything touch the cooling plate at the back of the fridge compartment.
- Don't:-** Store poisonous or dangerous substances in the fridge. Your fridge has been designed for the storage of edible foodstuffs only.
- Don't:-** Consume food which has been stored for an excessive time in the fridge.