

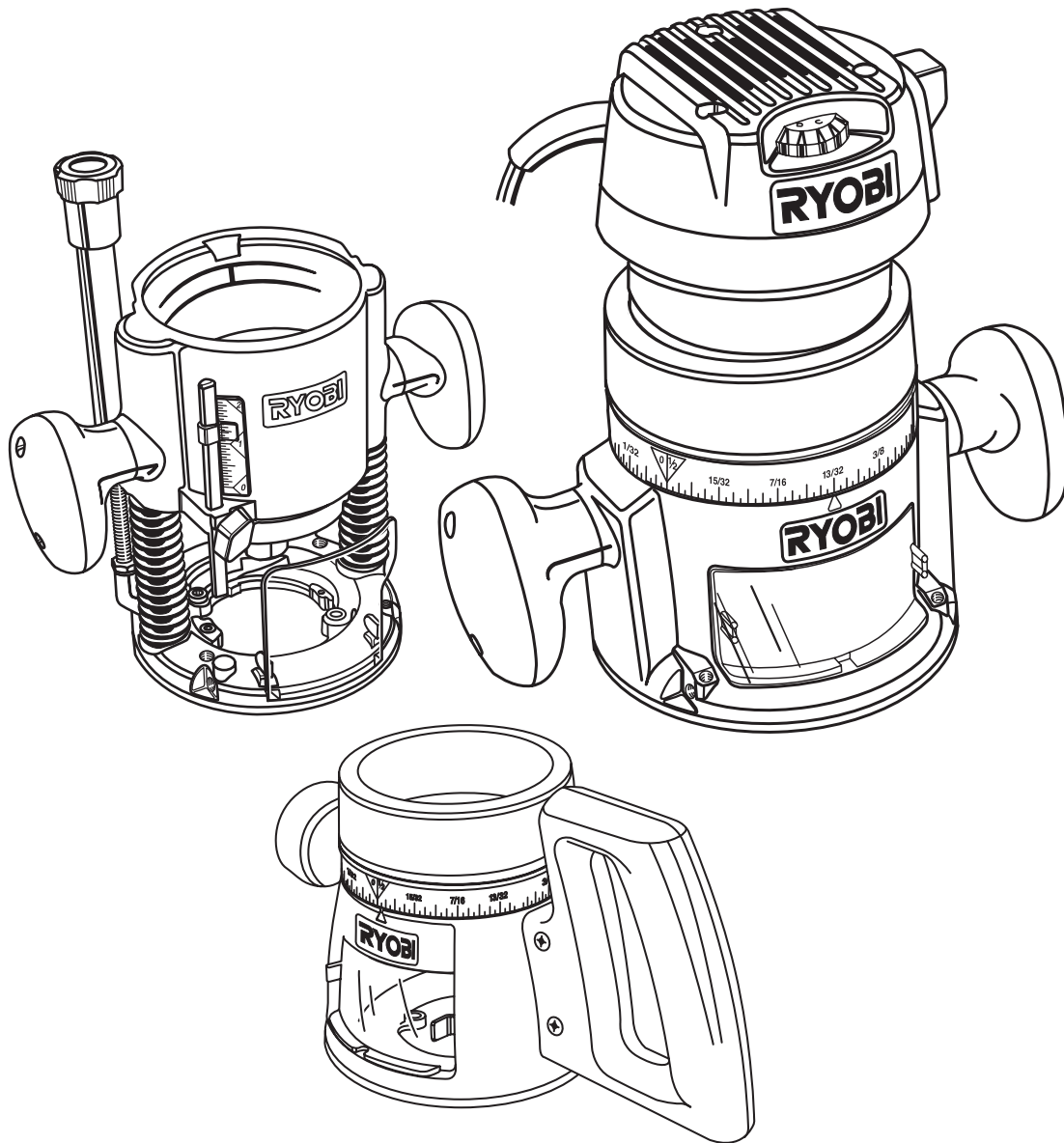

OPERATOR'S MANUAL

RE1802M1 ROUTER

With R181FB1 Fixed Base, R181PB1 Plunge Base, and R181DB1 D-Handle Base
Double Insulated



Your new router has been engineered and manufactured to our Ryobi's high standard for dependability, ease of operation, and operator safety. When properly cared for, the router will give you years of rugged, trouble-free performance.

⚠ WARNING:

To reduce the risk of injury, the user must read and understand the operator's manual before using this product.

Thank you for buying a Ryobi product.

SAVE THIS MANUAL FOR FUTURE REFERENCE

TABLE OF CONTENTS

■ Introduction	2
■ General Safety Rules	3-4
■ Specific Safety Rules	4
■ Symbols	5-6
■ Electrical	7
■ Features	8-9
■ Unpacking	9
■ Operation	10-22
■ Maintenance	23
■ Accessories	23
■ Parts, Ordering, and Service	24

INTRODUCTION

This router has many features for making its use more pleasant and enjoyable. Safety, performance, and dependability have been given top priority in the design of this tool making it easy to maintain and operate.

GENERAL SAFETY RULES

WARNING:

Read and understand all instructions. Failure to follow all instructions listed below, may result in electric shock, fire and/or serious personal injury.

SAVE THESE INSTRUCTIONS

WORK AREA

- **Keep your work area clean and well lit.** Cluttered benches and dark areas invite accidents.
- **Do not operate power tools in explosive atmospheres, such as in the presence of flammable liquids, gases, or dust.** Power tools create sparks which may ignite the dust or fumes.
- **Keep bystanders, children, and visitors away while operating a power tool.** Distractions can cause you to lose control.

ELECTRICAL SAFETY

- **Double insulated tools are equipped with a polarized plug (one blade is wider than the other). This plug will fit in a polarized outlet only one way. If the plug does not fit fully in the outlet, reverse the plug. If it still does not fit, contact a qualified electrician to install a polarized outlet. Do not change the plug in any way.** Double insulation  eliminates the need for the three-wire grounded power cord and grounded power supply system.
- **Avoid body contact with grounded surfaces such as pipes, radiators, ranges, and refrigerators.** There is an increased risk of electric shock if your body is grounded.
- **Don't expose power tools to rain or wet conditions.** Water entering a power tool will increase the risk of electric shock.
- **Do not abuse the cord. Never use the cord to carry the tools or pull the plug from an outlet. Keep cord away from heat, oil, sharp edges, or moving parts. Replace damaged cords immediately.** Damaged cords increase the risk of electric shock.
- **When operating a power tool outside, use an outdoor extension cord marked "W-A" or "W".** These cords are rated for outdoor use and reduce the risk of electric shock.

PERSONAL SAFETY

- **Stay alert, watch what you are doing and use common sense when operating a power tool. Do not use tool while tired or under the influence of drugs, alcohol, or medication.** A moment of inattention while operating power tools may result in serious personal injury.
- **Dress properly. Do not wear loose clothing or jewelry. Contain long hair. Keep your hair, clothing, and gloves away from moving parts.** Loose clothes, jewelry, or long hair can be caught in moving parts.

- **Avoid accidental starting. Be sure switch is off before plugging in.** Carrying tools with your finger on the switch or plugging in tools that have the switch on, invites accidents.
- **Remove adjusting keys or wrenches before turning the tool on.** A wrench or a key that is left attached to a rotating part of the tool may result in personal injury.
- **Do not overreach. Keep proper footing and balance at all times.** Proper footing and balance enables better control of the tool in unexpected situations.
- **Use safety equipment. Always wear eye protection.** Dust mask, non-skid safety shoes, hard hat, or hearing protection must be used for appropriate conditions.
- **Do not wear loose clothing or jewelry. Contain long hair.** Loose clothes, jewelry, or long hair can be drawn into air vents.
- **Do not use on a ladder or unstable support.** Stable footing on a solid surface enables better control of the tool in unexpected situations.

TOOL USE AND CARE

- **Use clamps or other practical way to secure and support the workpiece to a stable platform.** Holding the work by hand or against your body is unstable and may lead to loss of control.
- **Do not force tool. Use the correct tool for your application.** The correct tool will do the job better and safer at the rate for which it is designed.
- **Do not use tool if switch does not turn it on or off.** Any tool that cannot be controlled with the switch is dangerous and must be repaired.
- **Disconnect the plug from power source before making any adjustments, changing accessories, or storing the tool.** Such preventive safety measures reduce the risk of starting the tool accidentally.
- **Store idle tools out of the reach of children and other untrained persons.** Tools are dangerous in the hands of untrained users.
- **Maintain tools with care. Keep cutting tools sharp and clean.** Properly maintained tools with sharp cutting edges are less likely to bind and are easier to control.
- **Check for misalignment or binding of moving parts, breakage of parts, and any other condition that may affect the tool's operation. If damaged, have the tool serviced before using.** Many accidents are caused by poorly maintained tools.
- **Use only accessories that are recommended by the manufacturer for your model.** Accessories that may be suitable for one tool, may become hazardous when used on another tool.
- **Keep the tool and its handle dry, clean and free from oil and grease.** Always use a clean cloth when cleaning. Never use brake fluids, gasoline, petroleum-based products, or any strong solvents to clean your tool. Following this rule will reduce the risk of loss of control and deterioration of the enclosure plastic.

GENERAL SAFETY RULES

SERVICE

- **Tool service must be performed only by qualified repair personnel.** Service or maintenance performed by unqualified personnel could result in a risk of injury.
- **When servicing a tool, use only identical replacement parts. Follow instructions in the Maintenance section of this manual.** Use of unauthorized parts or failure to follow Maintenance Instructions may create a risk of electric shock or injury.

SPECIFIC SAFETY RULES

- **Hold tool by insulated gripping surfaces when performing an operation where the cutting tools may contact hidden wiring or its own cord.** Contact with a “live” wire will make exposed metal parts of the cutting tool “live” and shock the operator.

ADDITIONAL SAFETY RULES

- **Know your power tool. Read operator’s manual carefully. Learn its applications and limitations, as well as the specific potential hazards related to this tool.** Following this rule will reduce the risk of electric shock, fire, or serious injury.
- **Always wear safety glasses. Everyday eyeglasses have only impact-resistant lenses; they are NOT safety glasses.** Following this rule will reduce the risk of serious personal injury.
- **Protect your lungs. Wear a face or dust mask if the operation is dusty.** Following this rule will reduce the risk of serious personal injury.
- **Protect your hearing. Wear hearing protection during extended periods of operation.** Following this rule will reduce the risk of serious personal injury.
- **Inspect tool cords periodically and, if damaged, have repaired at your nearest authorized service center. Constantly stay aware of cord location.** Following this rule will reduce the risk of electric shock or fire.
- **Check damaged parts. Before further use of the tool, a guard or other part that is damaged should be carefully checked to determine that it will operate properly and perform its intended function. Check for alignment of moving parts, binding of moving parts, breakage of parts, mounting, and any other conditions that may affect its operation. A guard or other part that is damaged should be properly repaired or replaced by an authorized service center.** Following this rule will reduce the risk of shock, fire, or serious injury.
- **Do not abuse cord. Never carry the tool by the cord or yank it to disconnect it from the receptacle. Keep cord away from heat, oil, and sharp edges.** Following this rule will reduce the risk of electric shock or fire.
- **Make sure your extension cord is in good condition. When using an extension cord, be sure to use one heavy enough to carry the current your product will draw. A wire gage size (A.W.G.) of at least 14 is recommended for an extension cord 50 feet or less in length. A cord exceeding 50 feet is not recommended. If in doubt, use the next heavier gage. The smaller the gage number, the heavier the cord.** An undersized cord will cause a drop in line voltage resulting in loss of power and overheating.
- **Inspect for and remove all nails from lumber before routing.** Following this rule will reduce the risk of serious personal injury.
- **Drugs, alcohol, medication. Do not operate tool while under the influence of drugs, alcohol, or any medication.** Following this rule will reduce the risk of electric shock, fire, or serious personal injury.
- **Save these instructions.** Refer to them frequently and use them to instruct others who may use this tool. If you loan someone this tool, loan them these instructions also.

WARNING:









Some dust created by power sanding, sawing, grinding, drilling, and other construction activities contains chemicals known to cause cancer, birth defects or other reproductive harm. Some examples of these chemicals are:

- lead from lead-based paints,
- crystalline silica from bricks and cement and other masonry products, and
- arsenic and chromium from chemically-treated lumber.

Your risk from these exposures varies, depending on how often you do this type of work. To reduce your exposure to these chemicals: work in a well ventilated area, and work with approved safety equipment, such as those dust masks that are specially designed to filter out microscopic particles.



SYMBOLS

Some of the following symbols may be used on this tool. Please study them and learn their meaning. Proper interpretation of these symbols will allow you to operate the tool better and safer.

SYMBOL	NAME	DESIGNATION/EXPLANATION
V	Volts	Voltage
A	Amperes	Current
Hz	Hertz	Frequency (cycles per second)
W	Watt	Power
min	Minutes	Time
~	Alternating Current	Type of current
≡	Direct Current	Type or a characteristic of current
n_0	No Load Speed	Rotational speed, at no load
	Class II Construction	Double-insulated construction
.../min	Per Minute	Revolutions, strokes, surface speed, orbits etc., per minute
	Wet Conditions Alert	Do not expose to rain or use in damp locations.
	Read The Operator's Manual	To reduce the risk of injury, the user must read and understand the operator's manual before using this product.
	Eye Protection	Always wear safety goggles or safety glasses with side shields and a full face shield when operating this product.
	Safety Alert	Precautions that involve your safety.
	No Hands Symbol	Failure to keep your hands away from the blade will result in serious personal injury.
	No Hands Symbol	Failure to keep your hands away from the blade will result in serious personal injury.
	No Hands Symbol	Failure to keep your hands away from the blade will result in serious personal injury.
	No Hands Symbol	Failure to keep your hands away from the blade will result in serious personal injury.

SYMBOLS

The following signal words and meanings are intended to explain the levels of risk associated with this product.

SYMBOL	MEANING
	DANGER: Indicates an imminently hazardous situation, which, if not avoided, will result in death or serious injury.
	WARNING: Indicates a potentially hazardous situation, which, if not avoided, could result in death or serious injury.
	CAUTION: Indicates a potentially hazardous situation, which, if not avoided, may result in minor or moderate injury.
	(Without Safety Alert Symbol) Indicates a situation that may result in property damage.

SERVICE

Servicing requires extreme care and knowledge and should be performed only by a qualified service technician. For service we suggest you return the product to your nearest AUTHORIZED SERVICE CENTER for repair. When servicing, use only identical replacement parts.

WARNING:

Observe all normal safety precautions related to avoiding electrical shock.

WARNING:

To avoid serious personal injury, do not attempt to use this product until you read thoroughly and understand completely the operator's manual. Save this operator's manual and review frequently for continuing safe operation and instructing others who may use this product.

WARNING:



The operation of any tool can result in foreign objects being thrown into your eyes, which can result in severe eye damage. Before beginning operation, always wear safety goggles or safety glasses with side shields and a full face shield when needed. We recommend Wide Vision Safety Mask for use over eyeglasses or standard safety glasses with side shields. Always wear eye protection which is marked to comply with ANSI Z87.1.

SAVE THESE INSTRUCTIONS

ELECTRICAL

DOUBLE INSULATION

Double insulation is a concept in safety in electric power tools, which eliminates the need for the usual three-wire grounded power cord. All exposed metal parts are isolated from the internal metal motor components with protecting insulation. Double insulated tools do not need to be grounded.

Important: Servicing of a tool with double insulation requires extreme care and knowledge of the system and should be performed only by a qualified service technician. For service, we suggest you return the tool to your nearest authorized service center for repair. When servicing, use only identical Ryobi replacement parts.

WARNING:

The double insulated system is intended to protect the user from shock resulting from a break in the tool's internal wiring. Observe all normal safety precautions related to avoiding electrical shock.

ELECTRICAL CONNECTION

The router has a precision built electric motor. It should be connected to a power supply that is 120 volts, 60 Hz, AC only (normal household current). Do not operate this tool on direct current (DC). A substantial voltage drop will cause a loss of power and the motor will overheat. If your tool does not operate when plugged into an outlet, double-check the power supply.

EXTENSION CORDS

When using a power tool at a considerable distance from a power source, be sure to use an extension cord that has the capacity to handle the current the tool will draw. An undersized cord will cause a drop in line voltage, resulting in overheating and loss of power. Use the chart to determine the minimum wire size required in an extension cord. Only round jacketed cords listed by Underwriter's Laboratories (UL) should be used.

When working outdoors with a tool, use an extension cord that is designed for outside use. This type of cord is designated with "WA" on the cord's jacket.

Before using any extension cord, inspect it for loose or exposed wires and cut or worn insulation.

**Ampere rating (on tool faceplate)

0-2.0 2.1-3.4 3.5-5.0 5.1-7.0 7.1-12.0 12.1-16.0

Cord Length	Wire Size (A.W.G.)					
25'	16	16	16	16	14	14
50'	16	16	16	14	14	12
100'	16	16	14	12	10	—

**Used on 12 gauge - 20 amp circuit.

WARNING:

Keep the extension cord clear of the working area. Position the cord so that it will not get caught on lumber, tools or other obstructions while you are working with a power tool. Failure to do so can result in serious personal injury.

WARNING:

Check extension cords before each use. If damaged replace immediately. Never use tool with a damaged cord since touching the damaged area could cause electrical shock resulting in serious injury.

FEATURES

SPECIFICATIONS

Depth of Cut:

Plunge Base	0 - 2 in. (0 - 51 mm)
Fixed Base & D-Base	0 - 1-1/2 in. (0 - 38 mm)
Collet	1/2 in. (12.7 mm)
Collet Adaptor	1/4 in. (6 mm)
Peak Horsepower	2
Ampere	10 Amps
Input	120 Volts, 60 Hz, AC only
No Load Speed	15,000 - 25,000 RPM
Power Cord	10 ft. (3 m)
Total Net Weight	19 lbs. (8.6 kg.)

Before using this tool, familiarize yourself with all operating features and safety requirements. However, do not let familiarity with the tool make you careless.

This new router is equipped with the following features. See Figure 1.

MOTOR

The router kit has a powerful 10 amp motor with sufficient power to handle tough routing jobs. It delivers 2 peak horsepower for heavy duty performance.

SWITCH

The router has a conveniently located rocker switch.

SPINDLE LOCK

The spindle lock secures the spindle so that you only need one wrench to loosen the collet nut and change cutters.

DEPTH ADJUSTING RING

The depth adjusting ring allows you to adjust the depth of cut.

VARIABLE SPEED

The router's advanced electronic feature allow you to adjust the motor speed to required job conditions. The variable speed control is located on the front of the router and allows the router to develop a no load speed from 15,000 to 25,000/min.

LOCKING ARM

The locking arm secures the motor housing in the base.

CHIP SHIELD

A plastic chip shield on the base of the router provides protection against flying dust and chips.

ERGONOMIC DESIGN

The design of this tool provides for easy handling. It is designed for comfort and ease of grasp when operating in different positions and at different angles.

ELECTRICAL CONNECTION

Your router has a precision built electric motor. **It should be connected to a power supply that is 120 volts, 60 Hz, AC only (normal household current).** Do not operate this tool on direct current (DC). A substantial voltage drop will cause a loss of power and overheating. If your tool does not operate when plugged into an outlet, double-check the power supply.

DOUBLE INSULATION

Double insulation is a concept in safety in electric power tools, which eliminates the need for the usual three-wire grounded power cord. All exposed metal parts are isolated from the internal metal motor components with protecting insulation. Double insulated tools do not need to be grounded.

FEATURES

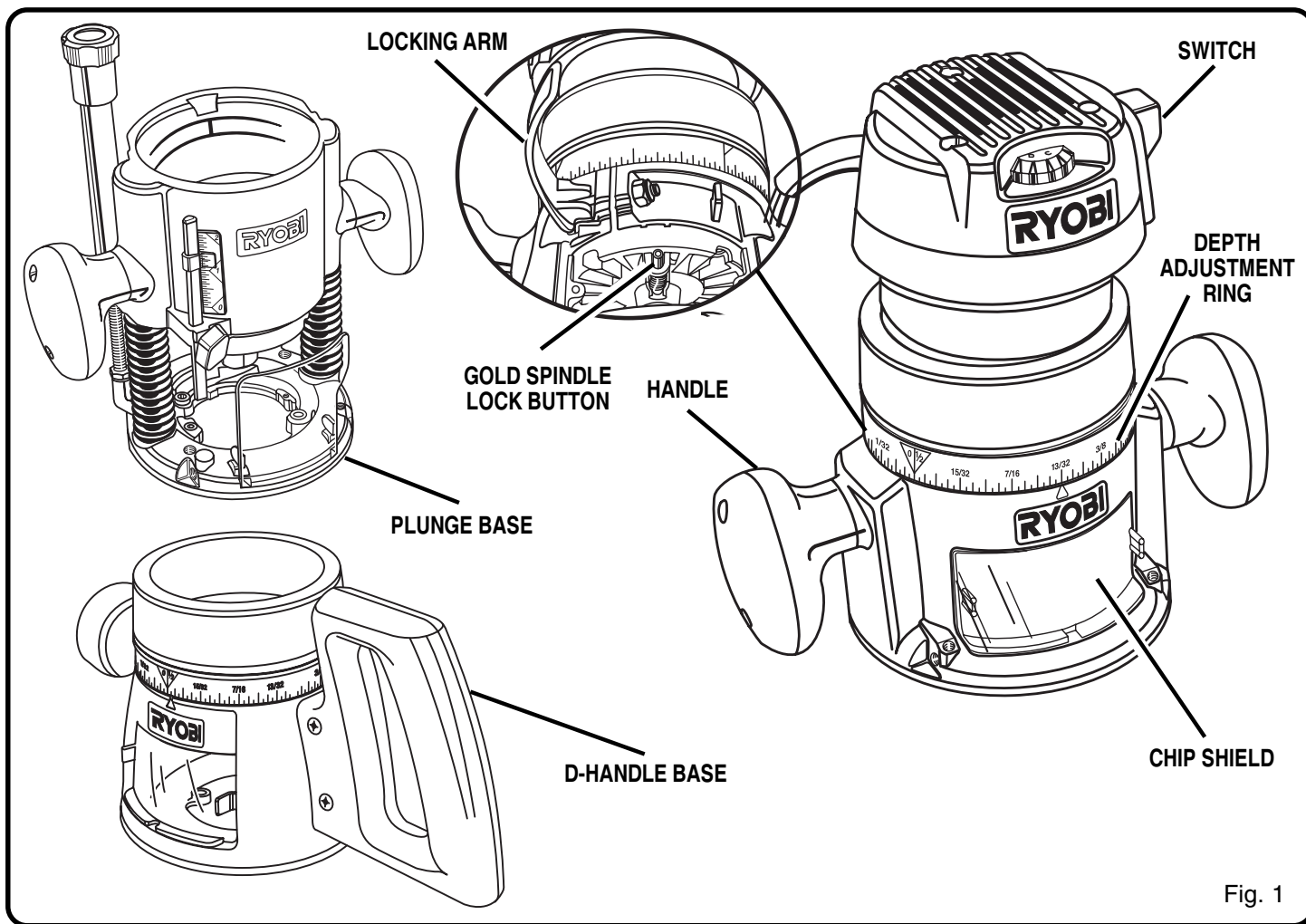

Fig. 1

UNPACKING

INSTRUCTIONS

When unpacking the tool:

- Carefully remove the tool and accessories from the box
- Make sure that all items listed in the packing list are included.
- Inspect the tool carefully to make sure no breakage or damage occurred during shipping.
- Do not discard the packing material until you have carefully inspected and satisfactorily operated the tool.
- If any parts are damaged or missing, please call 1-800-525-2579 for assistance.

⚠ WARNING:

If any parts are missing do not operate the tool until the missing parts are replaced. Failure to do so could result in possible serious personal injury.

PACKING LIST

- Router
- Fixed Base, Plunge Base, and D-Base
- Collet Adaptor
- Collet Wrench
- Tool Bag
- Template Guide Bushing Kit
- Straight Guide
- Operator's Manual
- Warranty Registration Card

⚠ WARNING:

The tool should never be connected to a power supply when you are assembling parts, making adjustments, cleaning, performing maintenance, or when the tool is not in use. Disconnecting the tool will prevent accidental starting that could cause injury.

OPERATION

⚠ WARNING:

Always wear safety goggles or safety glasses with side shields when using your router. Failure to do so could result in dust, shavings, chips, loose particles, or foreign objects being thrown in your eyes resulting in possible serious injury. If the operation is dusty, also wear a face or dust mask.

TURNING THE ROUTER ON/OFF

See Figure 2.

- To turn on the router: Move the switch to the **I** position.
- To turn off the router: Move the switch to the **O** position.

OPERATING THE ROUTER

See Figure 3.

Follow these steps to operate the router.

1. Unplug the router.

⚠ WARNING:

Failure to unplug the tool could result in accidental starting causing serious injury.

2. Securely tighten the cutter in the collet nut. Refer to "Removing/Inserting Cutters" later in this manual.
3. Set the desired depth of cut. Refer to "Adjusting Depth of Cut" later in this manual.
4. Secure the workpiece.
5. Plug the router into a power source.
6. Hold the router firmly with both hands.
7. Turn on the router and let the motor build to its full speed.
8. Feed the cutter slowly into the workpiece.

NOTE: Do not let the cutter contact the workpiece before starting the router and allowing it to develop full speed.

9. Turn off the router upon completion of cut, and let the motor come to a complete stop before removing the router from the workpiece.

⚠ WARNING:

Never place the router down on a work surface before the cutter stops.

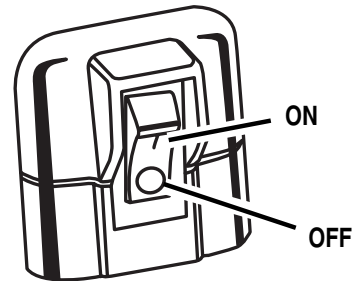

Fig. 2

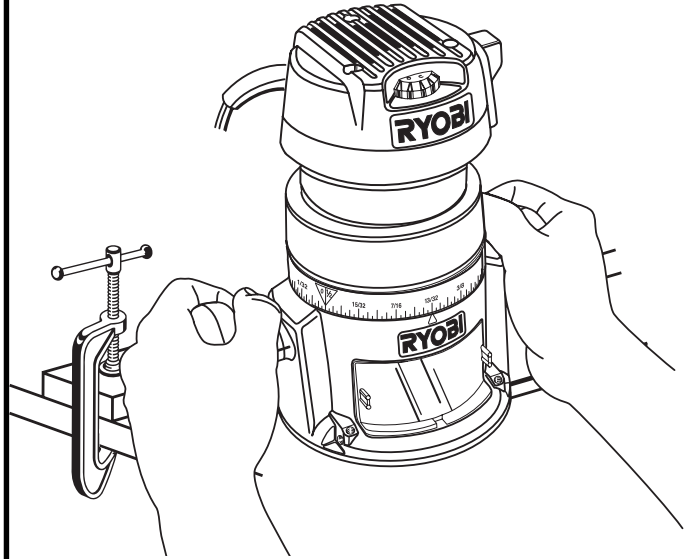

Fig. 3

⚠ WARNING:

Never attempt to use the router motor without first installing it in one of the approved bases. Failure to heed this warning could result in personal injury or damage to the motor.

OPERATION

⚠ WARNING:

Never connect the router to power supply when you are assembling parts, making adjustments, installing or removing cutters, or when not in use. Disconnecting the router prevents accidental starting that could cause serious injury.

REMOVING AND INSTALLING THE ROUTER BASE TO SWITCH FROM THE FIXED BASE OR D-HANDLE BASE TO THE PLUNGE BASE

See Figure 4.

TO REMOVE THE FIXED OR D-HANDLE BASE:

1. Unplug the router.

⚠ WARNING:

Failure to unplug the tool could result in accidental starting causing serious injury.

2. Place the router upside down with the Ryobi label away from you.
3. Loosen the locking arm on the base.
4. Depress and hold the gold spindle lock button. The gold spindle lock button will not depress fully unless it is in line with the hole in the collet.
5. If the gold spindle lock button does not depress fully, turn the collet nut while depressing the gold spindle lock button. As they align, the gold spindle lock button will depress fully.
6. Turn the depth adjusting ring counterclockwise until the motor is to its highest position. **NOTE:** As the motor is rising, the gold spindle lock button has to be depressed until it clears the rear window.
7. Align the indicator arrow on the depth adjustment ring with the indicator point on the base.
8. Pull the base until it dislodges from the motor housing.

TO INSTALL THE PLUNGE BASE

1. Unplug the router.
2. Place the plunge base on a flat surface.
3. Loosen the locking knob.
4. Align the groove in the motor housing with the rib inside the base. **NOTE:** The rib is located on the inside of the base in line with the handle.
5. Depress and hold the gold spindle lock button.
6. Slide the motor housing into the base.
7. Tighten the locking knob.

⚠ CAUTION:

Do not tighten the locking knob without the motor installed in the base. Failure to heed this caution may result in permanent damage to the locking mechanism.

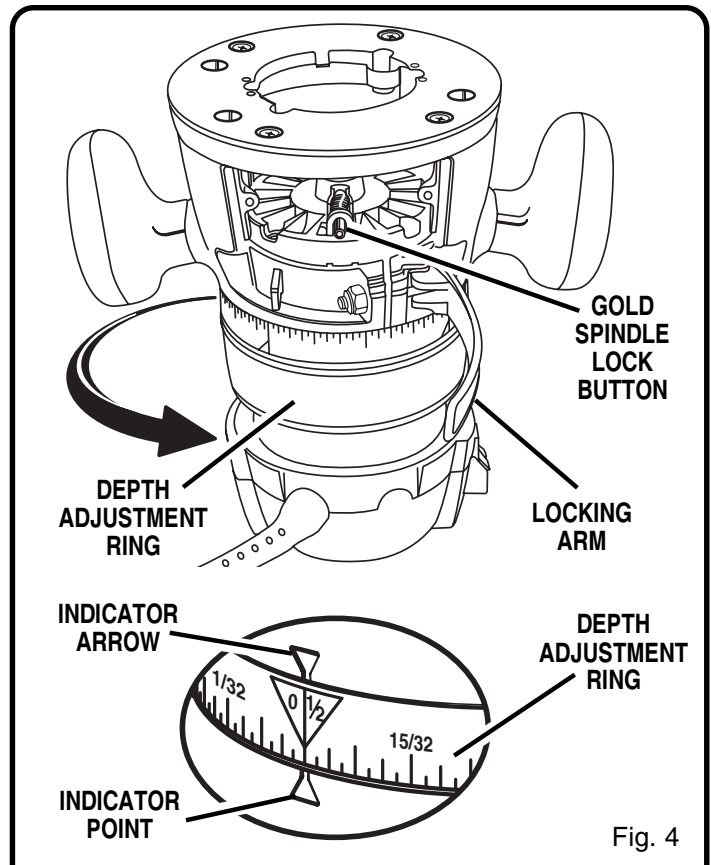

Fig. 4

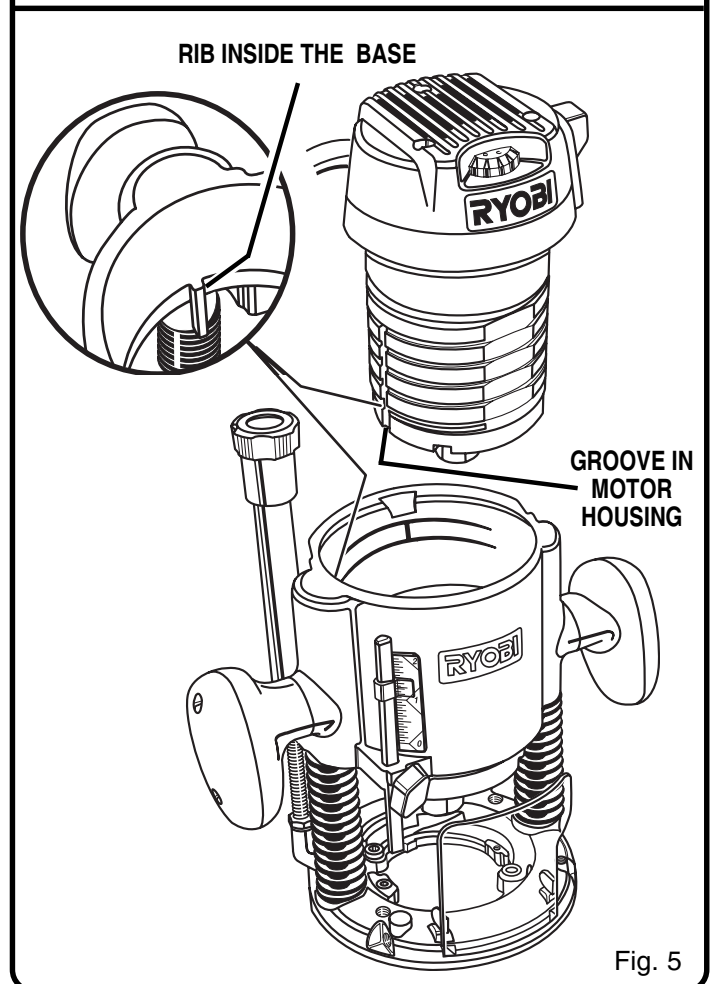

Fig. 5

OPERATION

TO SWITCH FROM PLUNGE BASE TO FIXED BASE OR D-HANDLE BASE

See Figures 6 and 7.

TO REMOVE THE PLUNGE BASE

1. Unplug the router.

⚠ WARNING:

Failure to unplug the tool could result in accidental starting causing serious injury.

2. Place the router on a flat surface.
3. Loosen the locking knob.
4. Depress and hold the gold spindle lock button. The gold spindle lock button will not depress fully unless it is in line with the hole in the collet.
5. If the gold spindle lock button does not depress fully, turn the collet nut while depressing the gold spindle lock button. As they align, the gold spindle lock button will depress fully.
6. Remove the motor housing from the plunge base.
NOTE: As the motor is being removed from the base, the gold spindle lock button has to be depressed until it clears the opening beneath the base.

TO INSTALL THE FIXED OR D-HANDLE BASE

1. Unplug the router.
2. Place the fixed or D-handle base on a flat surface.
3. Loosen the locking arm.
4. Align the indicator arrow on the depth adjustment ring with the indicator point on the base.
5. Align the groove in the motor housing with the tab inside of the base. **NOTE:** The tab is located on the inside of the base in line with the handle.
6. Depress and hold the gold spindle lock button on the motor.
7. Slide the motor housing into the base.
8. Turn the depth adjusting ring counterclockwise until the gold spindle lock snaps out as it clears the rear window, just below the locking arm.
9. Tighten the locking arm.

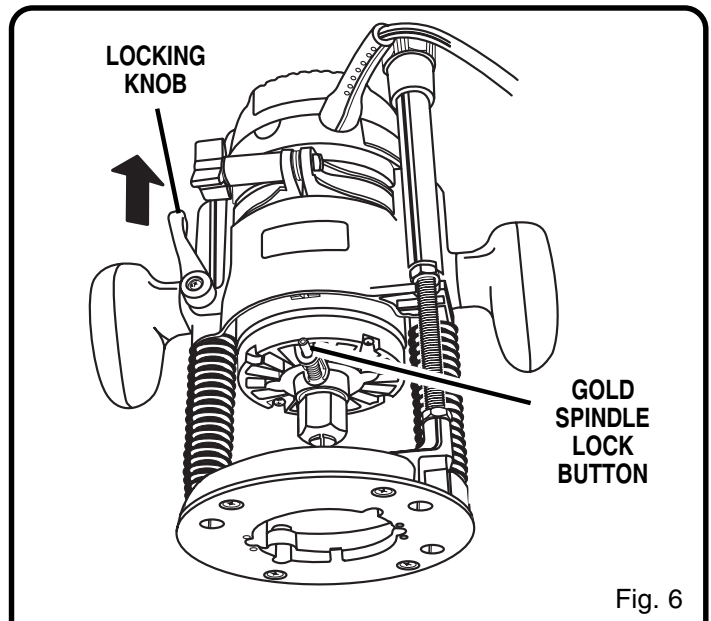

Fig. 6

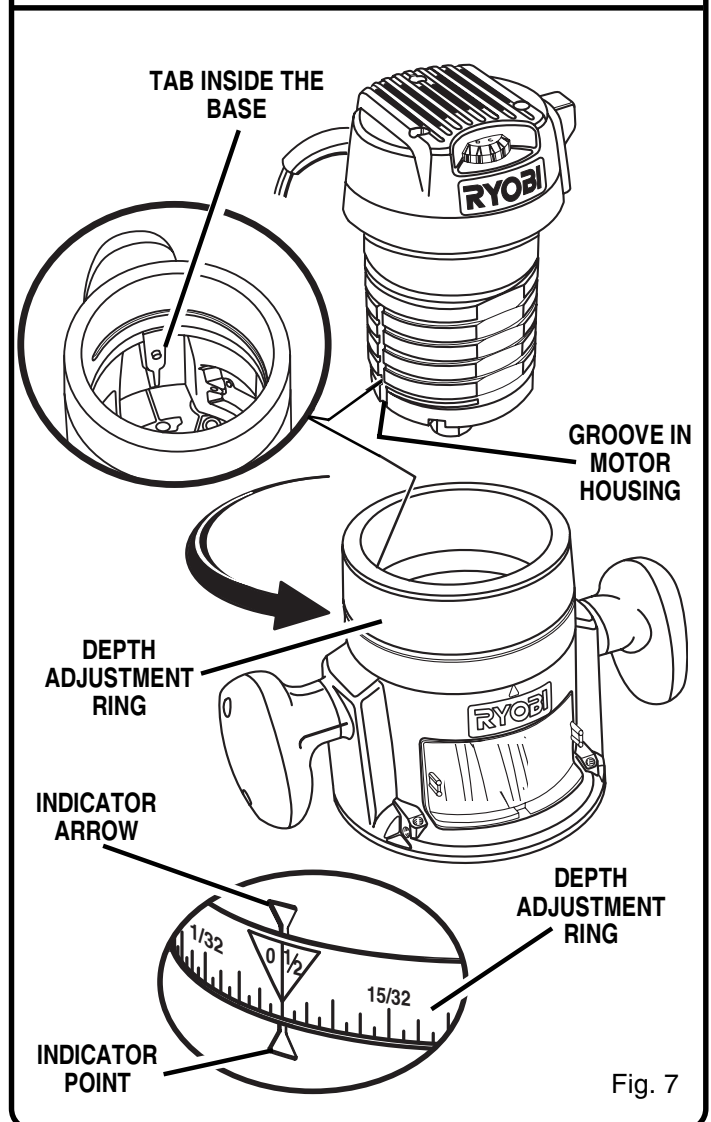

Fig. 7

OPERATION

REMOVING/INSERTING CUTTERS

See Figure 8.

Follow these steps to remove or insert cutters.

1. Unplug the router.

⚠ WARNING:

Failure to unplug the tool could result in accidental starting causing serious injury.

⚠ CAUTION:

To prevent damage to the spindle or spindle lock, always allow motor to come to a complete stop before engaging the spindle lock.

2. Place the router upside down on a workbench in order to gain easy access to collet nut.
3. Depress the gold spindle lock button.
4. Loosen the collet nut by turning it counterclockwise with the wrench provided.

⚠ WARNING:

If you are changing a cutter immediately after use, be careful not to touch the cutter or collet with your hands or fingers. They will get burned because of the heat buildup from cutting. Always use the wrench provided.

5. Choose one of these options:

■ *To remove the cutter:*

Remove the cutter from the collet.

■ *To insert the cutter:*

- a) Insert the shank of the cutter until the shank bottoms out, then pull it out 1/16 in. (1.6 mm) to allow for expansion when the bit gets hot.
- b) Tighten the collet nut securely by turning it clockwise with the wrench provided.
- c) Release the gold spindle lock button.

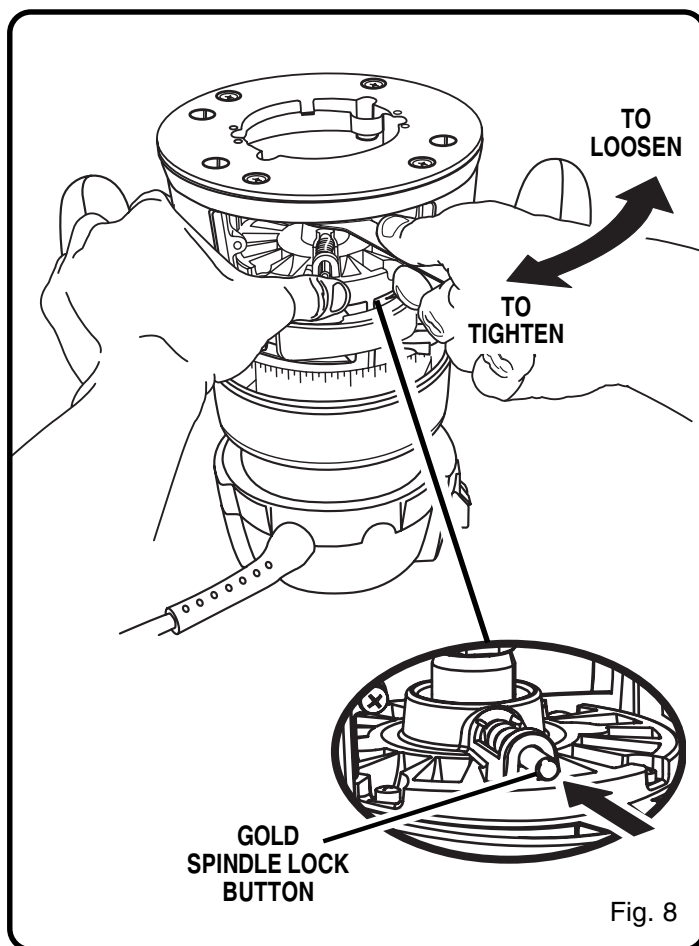

Fig. 8

⚠ WARNING:

If the collet nut is not securely tightened, the cutter may detach during use causing serious personal injury.

⚠ WARNING:

Do not use cutters with undersized shanks. Undersized shanks will not tighten properly and could be thrown from the tool causing injury.

⚠ WARNING:

Do not use cutters that are larger in diameter than the opening in router subbase. Use of such cutters will come in contact with the router subbase and damage both the cutter and router. The use of larger cutters could also cause possible loss of control or create other hazardous conditions that could result in serious personal injury or death.

OPERATION

ADJUSTING DEPTH OF CUT

Proper depth of cut depends on several factors: the peak horsepower of the router motor, the type of cutter, and the type of wood. A lightweight, low horsepower router is designed for making shallow cuts. A router with a high horsepower rating can safely cut deeper. Small cutters, such as veining bits with 1/16 in. (1.6 mm) cutting diameters, are designed to remove only small amounts of wood. Large cutters, such as straight-flute bits, are made to remove larger amounts of wood. You can make deeper cuts in soft woods, such as white pine, than in hardwoods, like oak or maple.

Based on these considerations, choose a depth of cut that will not place excessive strain on the router motor. If you find that extra force is needed or that the motor speed slows down considerably, turn off the router and reduce the depth of cut. Then, make the cut in two or more passes.

When routing a groove that is too deep to safely cut in one pass, it is best to make the cut in several passes. We recommend that cuts be made at a depth not exceeding 1/8 in. (3.2 mm) and that several passes be made to reach deeper cuts.

Adjusting the depth of cut for the plunge router is different from adjusting the depth of cut for the fixed router.

TO ADJUST DEPTH OF CUT FOR FIXED BASE OR D-BASE ROUTERS

See Figures 9 and 10.

Follow these steps to adjust depth of cut for fixed routers.

1. Unplug the router.

⚠ WARNING:

Failure to unplug the tool could result in accidental starting causing serious injury.

2. Place the router on a flat surface.
3. Loosen the locking arm.
4. Turn the depth adjusting ring counterclockwise until the tip of the cutter touches the flat surface.
5. Turn the depth indicator ring until the zero lines up with the indicator point on the base.
6. Position the router so that the cutter can extend below the subbase for desired depth of cut.
7. Turn the depth adjusting ring to obtain the desired depth of cut.
8. Tighten the locking arm securely.

NOTE: To adjust the depth of cut when the router is mounted to a router table, turn the depth adjustment ring until the cutter reaches the desired depth of cut.

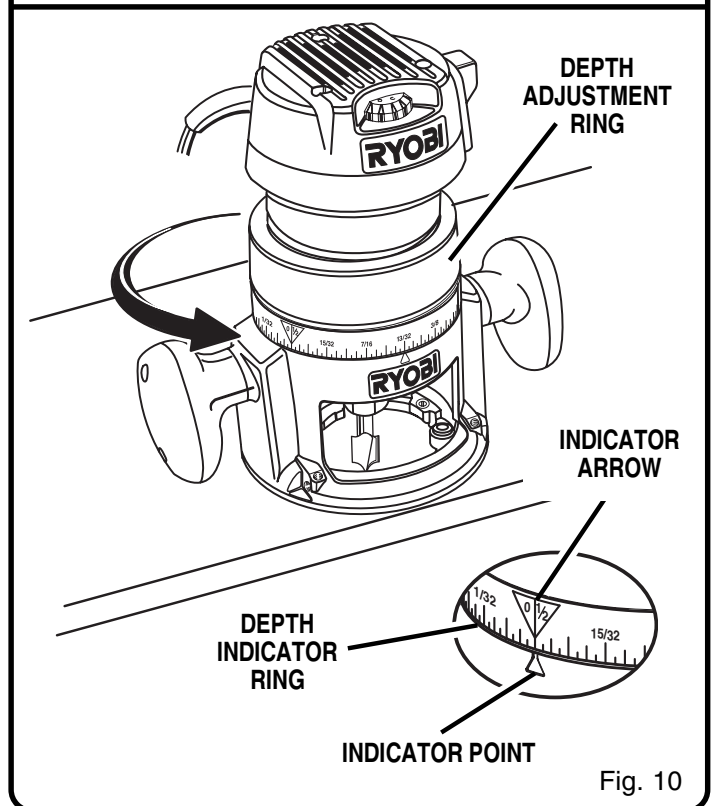
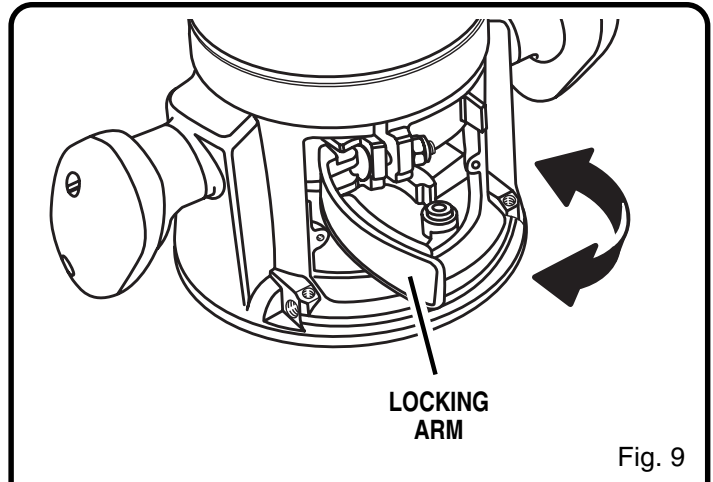

OPERATION

TO ADJUST DEPTH OF CUT FOR PLUNGE BASE ROUTERS

See Figures 11, 12, and 13.

Follow these steps to adjust depth of cut for plunge base routers.

1. Unplug the router.

⚠ WARNING:

Failure to unplug the tool could result in serious injury due to accidental starting.

2. Place the router on a flat surface.
3. Loosen the stop bar knob.
4. Unlock the plunge lock lever.
5. Plunge the router until the tip of the cutter touches the flat surface.
6. Lock the plunge lock lever.
7. Move the stop bar down so it touches the depth stop.
8. Tighten the stop bar knob securely.
9. Set the depth indicator to zero.
10. Loosen the stop bar knob.
11. Set the depth indicator to the desired depth of cut.
Note: Each mark on the scale indicates 1/16 in. (1.6 mm).
12. Tighten the stop bar knob securely.
13. Unlock the plunge lock lever.
14. Position the router so that the cutter can extend below the subbase for desired depth of cut.
15. Plunge the router until the stop bar touches the depth stop.
16. Lock the plunge lock lever to position the cutter at the desired depth of cut.

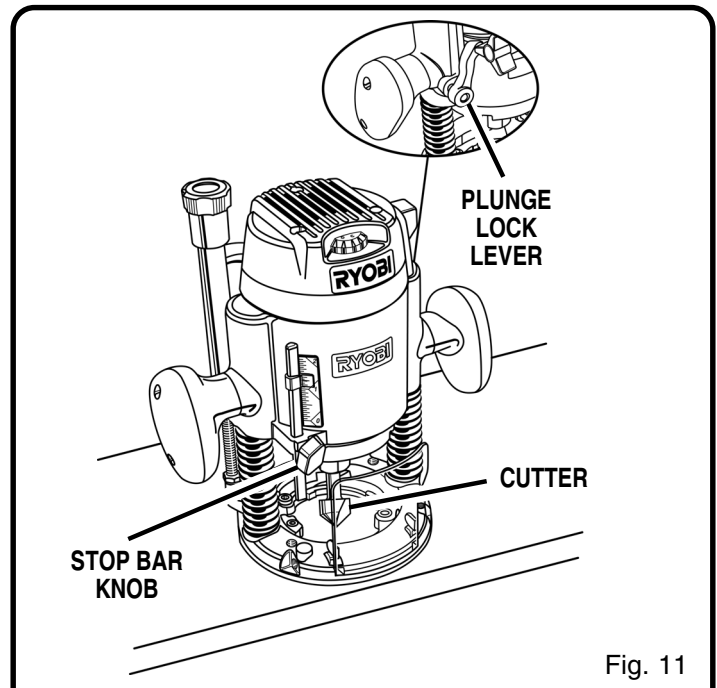

Fig. 11

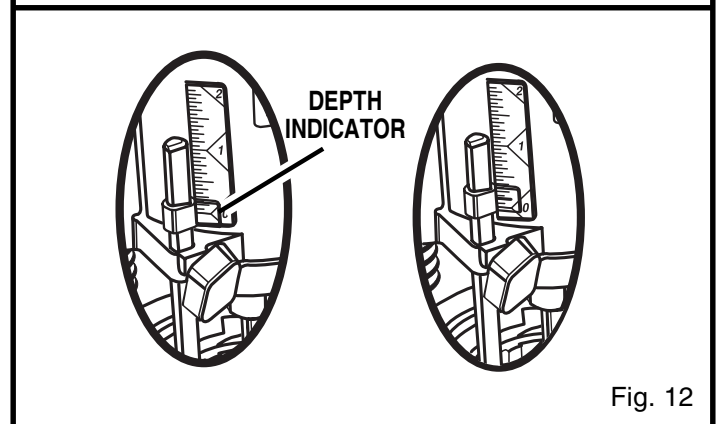

Fig. 12

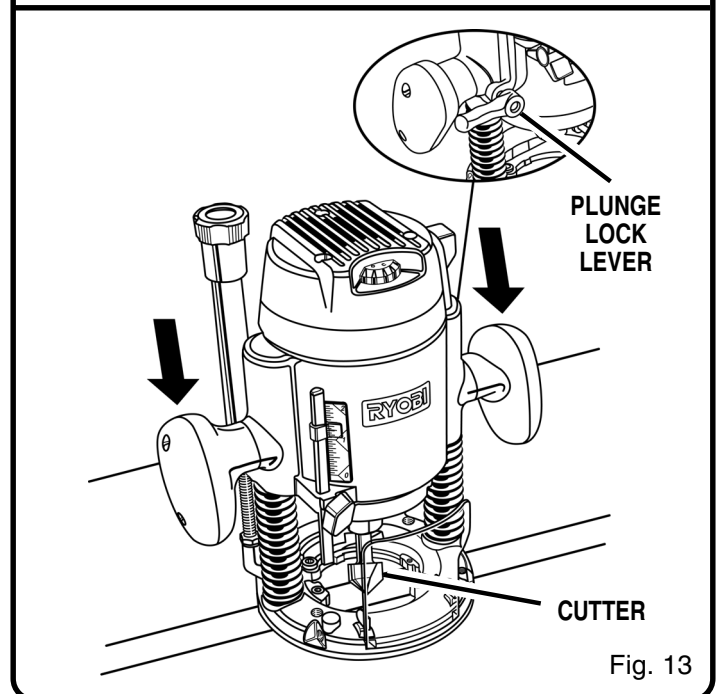

Fig. 13

OPERATION

FEEDING THE ROUTER

The “secret” of professional routing and edge shaping lies in making a careful set-up for the cut and in selecting the proper rate of feed.

DIRECTION (EXTERNAL)

See Figures 14 and 15.

When routing, the cutter rotates clockwise. Therefore, you should feed the router into the workpiece from left to right. When you feed the router from left to right, the rotation of the cutter pulls the router against the workpiece. If you feed the router in the opposite direction, the rotational forces of the spinning bit tend to throw the router away from the workpiece. This action could cause you to lose control of the router.

The router motor and bit revolve in a clockwise direction. This gives the tool a slight tendency to twist in a counterclockwise direction, especially when the motor revs up.

Because of the extremely high speed of bit rotation during a proper feeding operation, there is very little kickback to contend with under normal conditions. However, if the bit strikes a knot, hard grain, foreign object, etc. that affects the normal progress of the cutting action, there will be a slight kickback. This kickback is sufficient to spoil the trueness of your cut if you are not prepared. Such a kickback is always in the direction opposite to the direction of bit rotation.

To guard against such a kickback, plan your setup and direction of feed so that you will always be thrusting the tool—to hold it against whatever you are using to guide the cut—in the same direction that the leading edge of the bit is moving. In short, the thrust should be in a direction that keeps the sharp edges of the bit continuously biting straight into new (uncut) wood.

DIRECTION (INTERNAL)

See Figure 16.

Whenever you are routing a groove, your travel should be in a direction that places whatever guide you are using at the right-hand side. That is, when the guide is positioned as shown in the first part of the figure, tool travel should be from left to right and counterclockwise around curves. When the guide is positioned as shown in the second part of the figure, tool travel should be right to left and clockwise around curves. If there is a choice, the first setup is generally the easiest to use. In either case, the sideways thrust you use is against the guide.

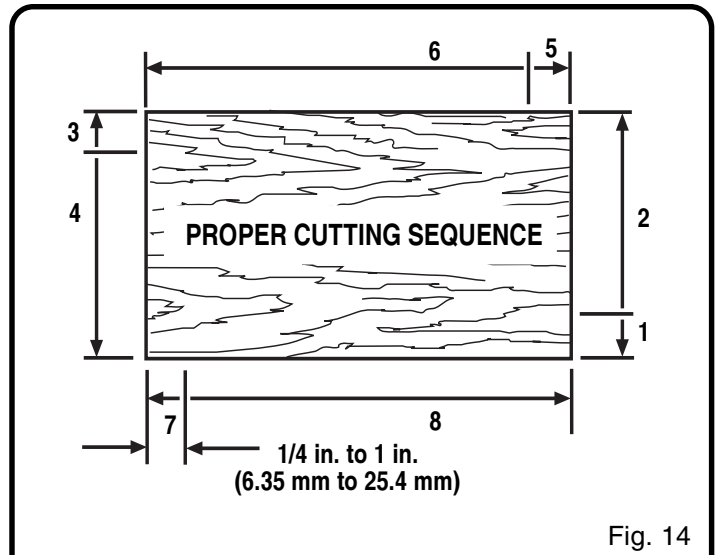

Fig. 14

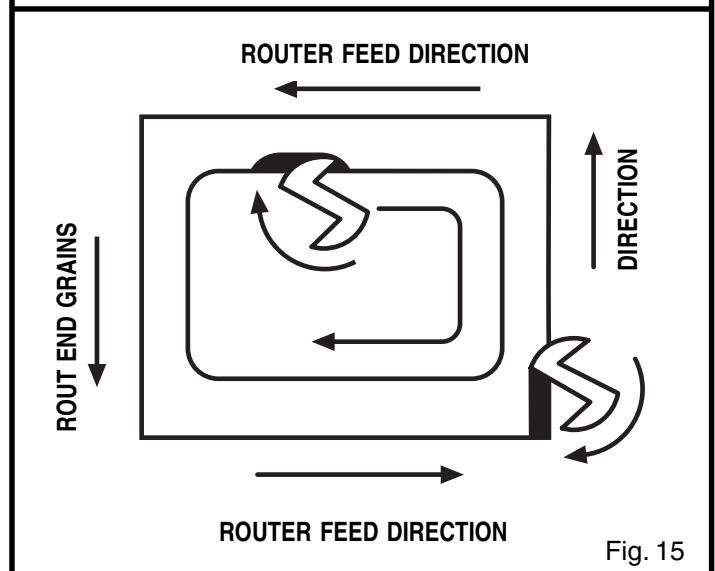

Fig. 15

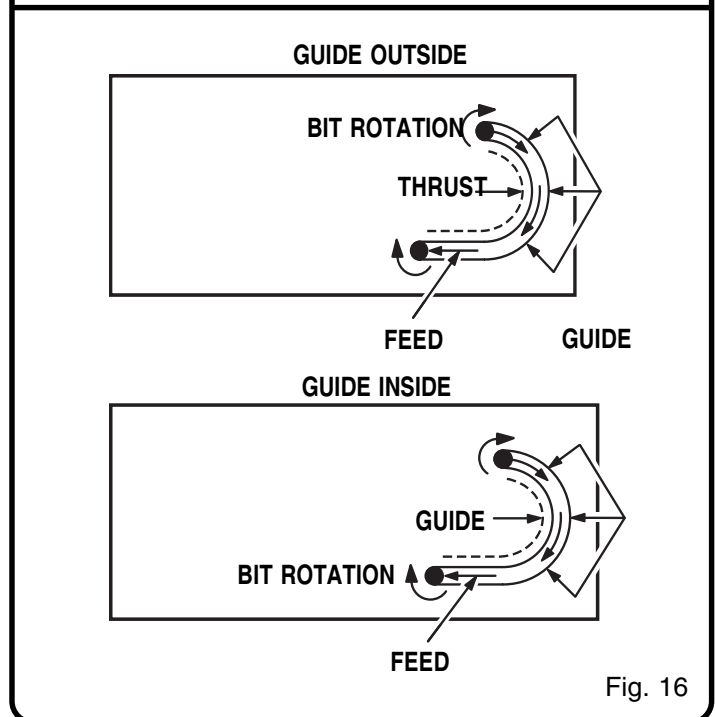

Fig. 16

OPERATION

RATE OF FEED

The proper rate of feed depends on several factors: the hardness and moisture content of the wood, the depth of cut, and the cutting diameter of the bit. When cutting shallow grooves in soft woods such as pine, a faster rate of feed can be used. When making deep cuts in hardwoods such as oak, a slower rate of feed should be used.

The best rate of feed is one that does not slow down the router motor more than one-third of its no-load speed. If the router is fed too fast, it will take large chips out of the wood and leave gouge marks. If the router is fed too slow, it will scorch or burn the wood.

Feeding Too Fast

See Figure 17.

Clean, smooth routing and edge shaping can be done only when the bit is revolving at a relatively high speed and is taking very small bites to produce tiny, cleanly severed chips. If your router is forced to move forward too fast, the RPM of the bit becomes slower than normal in relation to its forward movement. As a result, the bit must take bigger bites as it revolves. "Bigger bites" mean bigger chips, and a rougher finish. Bigger chips also require more power, which could result in the router motor becoming overloaded.

Under extreme force-feeding conditions the relative RPM of the bit can become so slow—and the bites it has to take so large — that chips will be partially knocked off (rather than fully cut off), resulting in splintering and gouging of the workpiece.

Your router is an extremely high-speed tool (15,000 - 25,000 RPM no-load speed), and will make clean, smooth cuts if allowed to run freely without the overload of a forced (too fast) feed. Three things that cause "force feeding" are bit size, depth-of-cut, and workpiece characteristics. The larger the bit or the deeper the cut, the more slowly the router should be advanced. If the wood is very hard, knotty, gummy or damp, the operation must be slowed still more.

You can always detect "force feeding" by the sound of the motor. Its high-pitched whine will sound lower and stronger as it loses speed. Also, the strain of holding the tool will be noticeably increased.

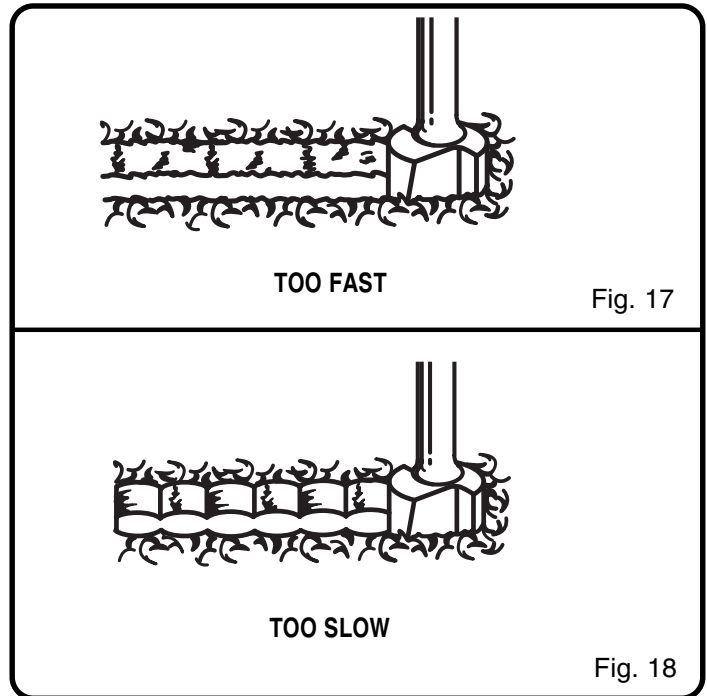

Feeding Too Slow

See Figure 18.

It is also possible to spoil a cut by moving the router forward too slowly. When it is advanced into the work too slowly, a revolving bit does not dig into new wood fast enough to take a bite; instead, it simply scrapes away sawdust-like particles. Scraping produces heat, which can glaze, burn, or mar the cut and in extreme cases, can even overheat the bit so as to destroy its hardness.

In addition, it is more difficult to control a router when the bit is scraping instead of cutting. With practically no load on the motor the bit will be revolving at close to top RPM, and will have a much greater than normal tendency to bounce off the sides of the cut (especially if the wood has a pronounced grain with hard and soft areas). As a result, the cut produced may have rippled, instead of straight sides.

"Too-slow feeding" can also cause your router to take off in a wrong direction from the intended line of cut. **Always grasp and hold your router firmly with both hands when routing.**

You can detect "too-slow feeding" by the runaway, high-pitched sound of the motor; or by feeling the "wobble" of the bit in the cut.

OPERATION

DETERMINING DEPTH OF CUT

See Figure 19.

As previously mentioned, the depth of cut is important because it affects the rate of feed that, in turn, affects the quality of the cut (and, also, the possibility of damage to your router motor and bit). A deep cut requires a slower feed than a shallow one, and a too deep cut will cause you to slow the feed so much that the bit is no longer cutting, it is scraping, instead.

Making a deep cut is never advisable. The smaller bits — especially those only 1/16 inch (1.6 mm) in diameter — are easily broken off when subjected to too much side thrust. A large enough bit may not be broken, but if the cut is too deep a rough cut will result — and it may be very difficult to guide and control the bit as desired. For these reasons, we recommend that you do not exceed 1/8 in. depth of cut in a single pass, regardless of the bit size or the softness or condition of the workpiece.

To make deeper cuts it is therefore necessary to make as many successive passes as required, lowering the bit 1/8 in. for each new pass. In order to save time, do all the cutting necessary at one depth setting, before lowering the bit for the next pass. This will also assure a uniform depth when the final pass is completed.

ROUTING

Your router is a versatile tool and can be used for many different applications. You may rout grooves, carve designs using a template, carve designs by freehand, taper table and chair legs, mortise door jambs, or create joints.

ROUTING GROOVES

See Figure 20.

When routing across the face of boards, set router at desired depth of cut, place the edge of router base against workpiece, and turn on the router. Slowly feed the cutter into the workpiece along desired line of cut.

⚠ WARNING:

If desired depth of cut is greater than can be safely cut in one pass, make cuts in two or more passes.

When routing straight cuts across stock, clamp a straight edge to the workpiece to use as a guide. Position the straightedge parallel to the line of cut and offset the distance between the cutting edge of the cutter and the edge of the router base. Hold the router base against the straightedge and rout the groove.

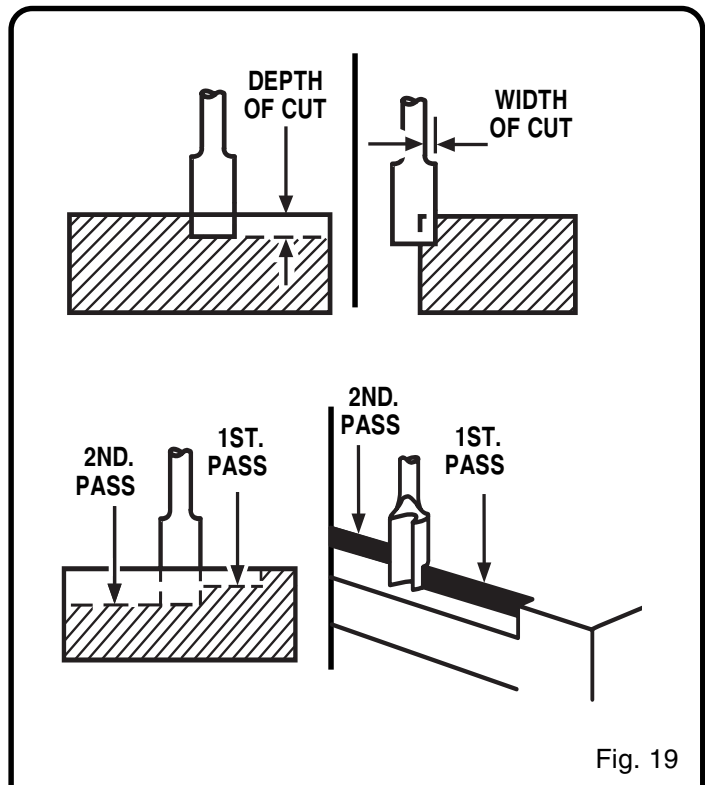

Fig. 19

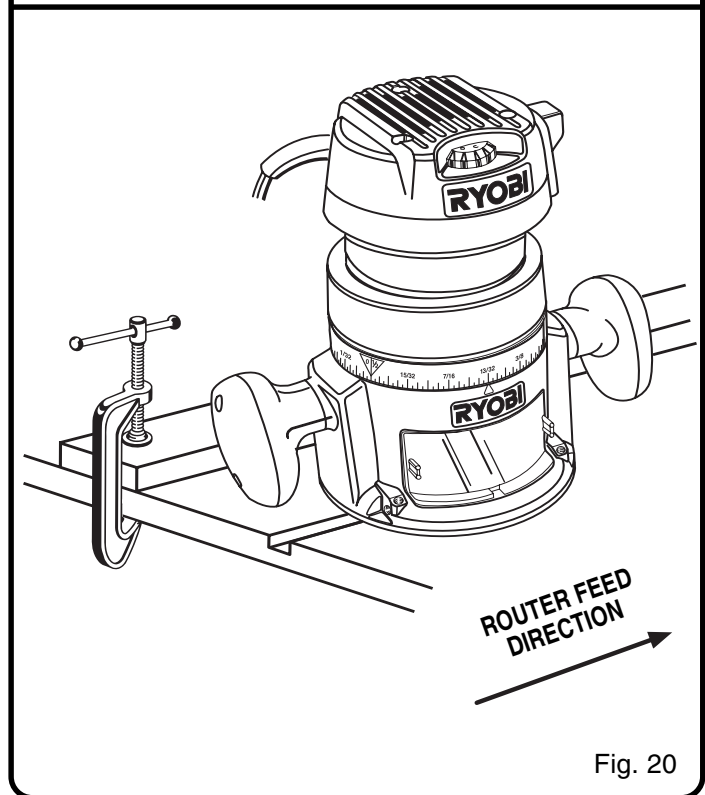

Fig. 20

OPERATION

When routing a groove wider than the diameter of the cutter, clamp a straightedge on both sides of the cutlines. Position both guides parallel to the desired line of cut and spaced equal distances from the desired edges of the groove. Rout along one guide; then, reverse direction and rout along the other guide. Clean out any remaining waste in the center of the groove freehand.

ROUTING BY FREEHAND

See Figure 21.

When used freehand, your router becomes a flexible and versatile tool. This flexibility makes it possible to easily rout signs, relief sculptures, etc.

There are two basic techniques for freehand routing:

- Routing letters, grooves, and patterns into wood.
- Routing out the background, leaving the letters or pattern raised above the surface.

When freehand routing, we suggest the following:

- Draw or layout the pattern on workpiece.
- Choose the appropriate cutter.

NOTE: A core box or V-groove bit is often used for routing letters and engraving objects. Straight bits and ball mills are often used to make relief carvings. Veining bits are used to carve small, intricate details.

- Rout the pattern in two or more passes. Make the first pass at 25% of the desired depth of cut. This will provide better control as well as being a guide for the next pass.

NOTE: Do not rout deeper than 1/8 in. per pass.

⚠ WARNING:

Do not use large router bits for freehand routing. Use of large router bits when freehand routing could cause loss of control or create other hazardous conditions that could cause possible serious personal injury. When using a router table, large router bits should be used for edging only. Do not use router bits that are larger in diameter than the opening in router subbase for any purpose.

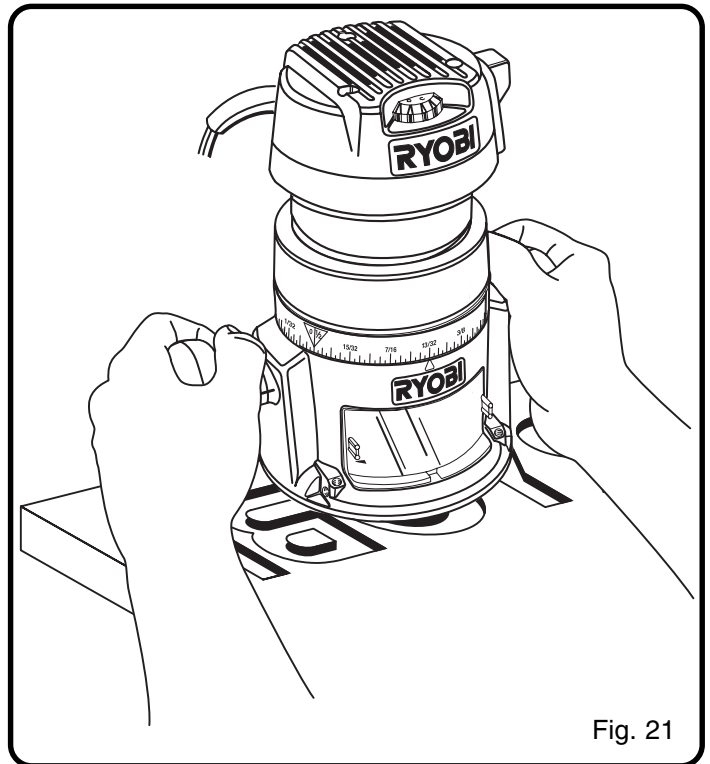

Fig. 21

OPERATION

EDGING WITH PILOTS

See Figure 22.

You can cut rabbets and molded edges using piloted cutters. The pilot, which extends below the cutter, allows the cutter to turn while the pilot follows the edge of the workpiece. Some pilots are solid extensions of the cutter. Others are ball bearing guides that are fastened to the end of the cutter.

Arbor-type bits with pilots are excellent for quick, easy edge shaping. They follow workpiece edges that are either straight or curved. The pilot prevents the bit from making too deep a cut. Holding the pilot firmly in contact with the workpiece edge throughout the cut prevents the cut from becoming too shallow.

Whenever the workpiece thickness together with the desired depth of cut (as adjusted by router depth setting) are such that only the top part of the edge is to be shaped (leaving at least a 1/16 inch [1.6 mm] thick uncut portion at bottom), the pilot can ride against the uncut portion, which serves to guide it. However, if the workpiece is too thin or the bit is set so low that there will be no uncut edge to ride the pilot against, an extra board must be placed under the workpiece to act as a guide. This guide board must have exactly the same contour — straight or curved — as the workpiece edge. If the guide is positioned so that its edge is flush with the workpiece edge, the bit will make a full cut (in as far as the bit radius). On the other hand, if the guide is positioned as shown (out from the workpiece edge), the bit will make less than a full cut — which will alter the shape of the finished edge.

NOTE: When edge shaping with guides, you can use any of the piloted bits without a pilot. The size (diameter) of the pilot determines the maximum cut width that you can make with the pilot against the workpiece edge. The small pilot exposes all of the bit; the large one reduces this amount by 1/16 inch (1.6 mm).

When routing all edges of a panel or board, rout the end grain first. Any splintering that occurs at the corners will then be removed when routing the sides. Start each side 1/4 in. (6.35 mm) away from the end. Feed the cutter into the wood until the pilot contacts the uncut edge. Then, slowly back the router to shape the corner. Next, move the router forward to shape the rest of the edge. Be careful to keep the pilot pressed against the uncut edge. Repeat this procedure on each side of the panel.

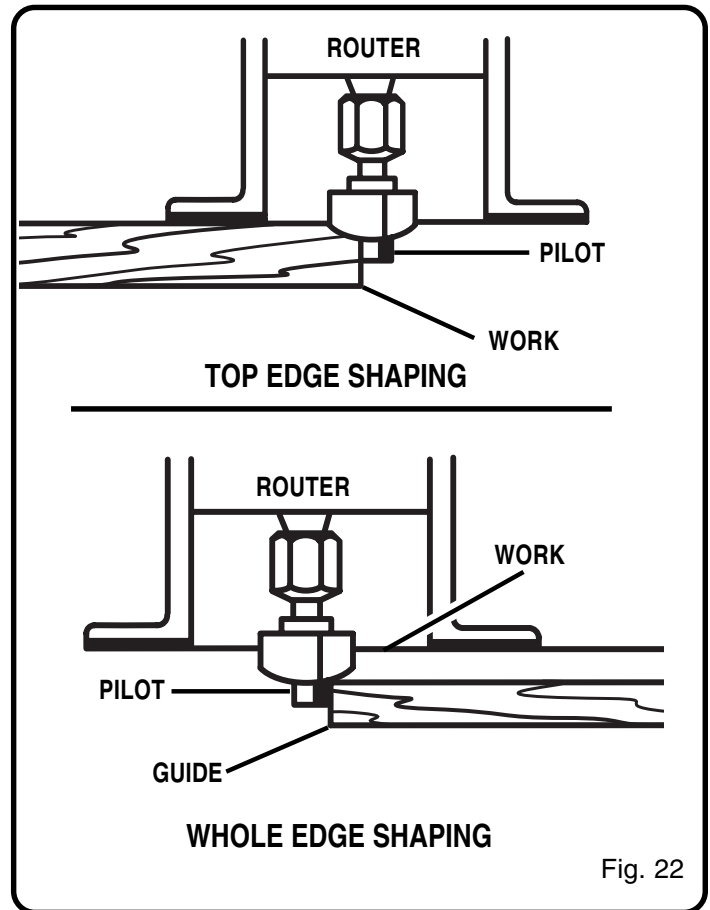

Fig. 22

OPERATION

ROUTER TEMPLATE GUIDE BUSHING KIT

Sizes: 5/16 in., 7/16 in. (Short), 7/16 in. (Long), 1/2 in., and 5/8 in.

ROUTING WITH THE GUIDE BUSHING

You can accurately duplicate curves and complex shapes by fitting your router with a template guide bushing that extends below the subbase. The router bit passes through the guide bushing. The guide bushing then rides against a template.

TO INSTALL THE TEMPLATE GUIDE BUSHING

See Figures 23 and 24.

- Unplug your router.

⚠ WARNING:

Failure to unplug your router could result in accidental starting causing serious injury.

- Place router upside down on workbench.
- Place template guide bushing in recessed portion of router subbase.
- Align the cutouts in guide bushing with threaded holes in subbase.
- Secure guide bushing to router subbase with screws provided.
- Tighten screws securely.
- Loosen the four subbase screws that secure the subbase to the router base.
- Set the cutter to desired depth and lock the depth lock.
- Adjust the subbase so that the end of the cutter is centered in the collar of the bushing.
- Tighten the four subbase screws securely.

⚠ WARNING:

Failure to tighten screws could cause the bit to come in contact with the bushing resulting in serious injury.

Secure the template to the workpiece. Set the router to the desired depth of cut and turn it on. Place the router subbase on the template with the collar of the guide bushing against the edge of the template. Lower the cutter into the workpiece and proceed around the template, keeping the guide bushing pressed against the template edge. When routing with the template guide bushings, it is necessary to allow for size differences between the cutting edge of the cutter and the face of the guide bushing collar. When making templates, always allow for this size difference.

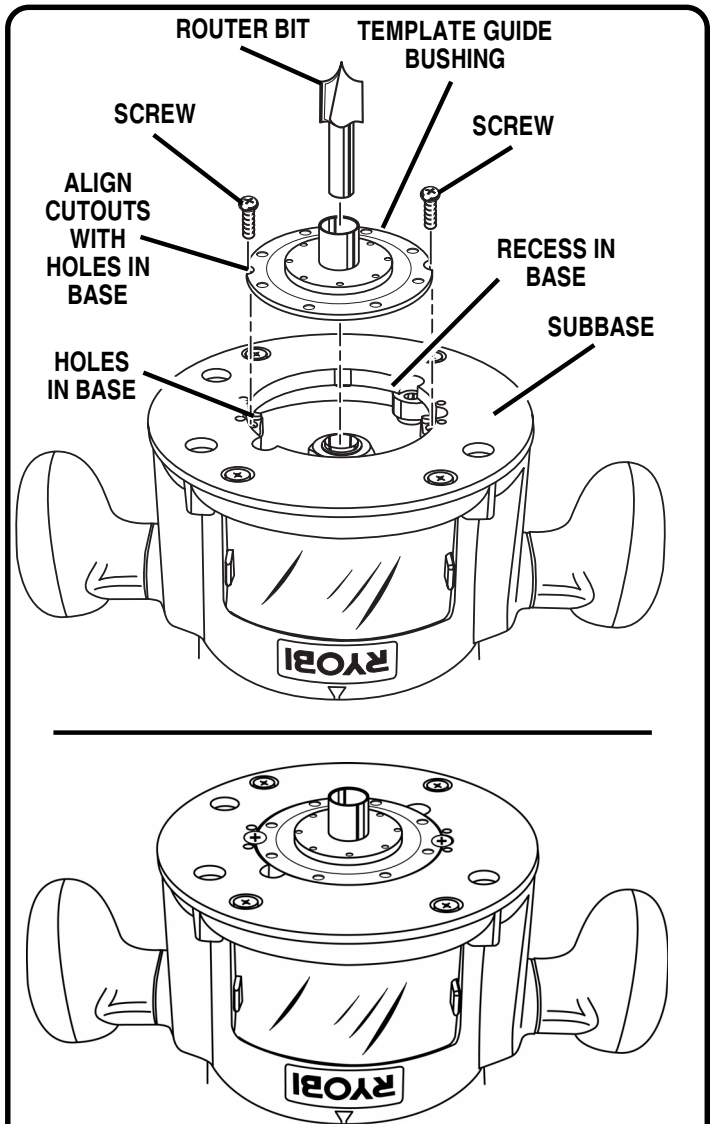

Fig. 23

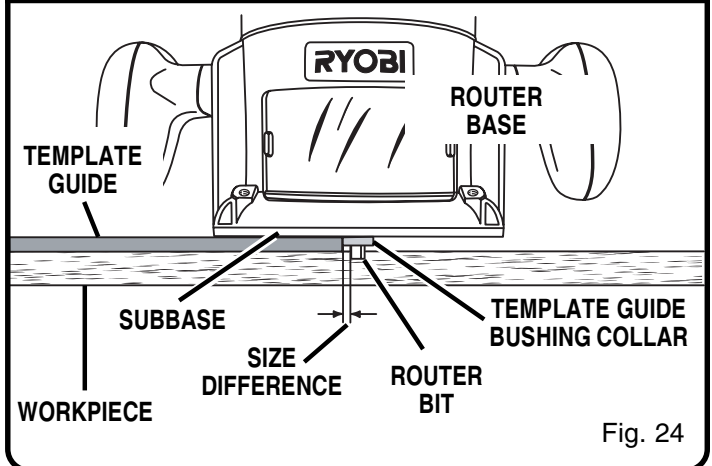

Fig. 24

OPERATION

STRAIGHT GUIDE

The straight guide is used as an edge guide that slides against the edge of a board to guide the cutter through the cut. The straight guide can be used from either side of the router base.

TO INSTALL THE STRAIGHT GUIDE

See Figures 25 and 26.

- Unplug your router.

⚠ WARNING:

Failure to unplug your router could result in accidental starting causing serious injury.

- Slide the two straight guide mounting posts into the holes in the side of the router base.
- Set the straight guide to a desired location.
- To secure the straight guide, install the two knob screws into the tapped holes in the base of the router.
- Tighten both knob screws securely.

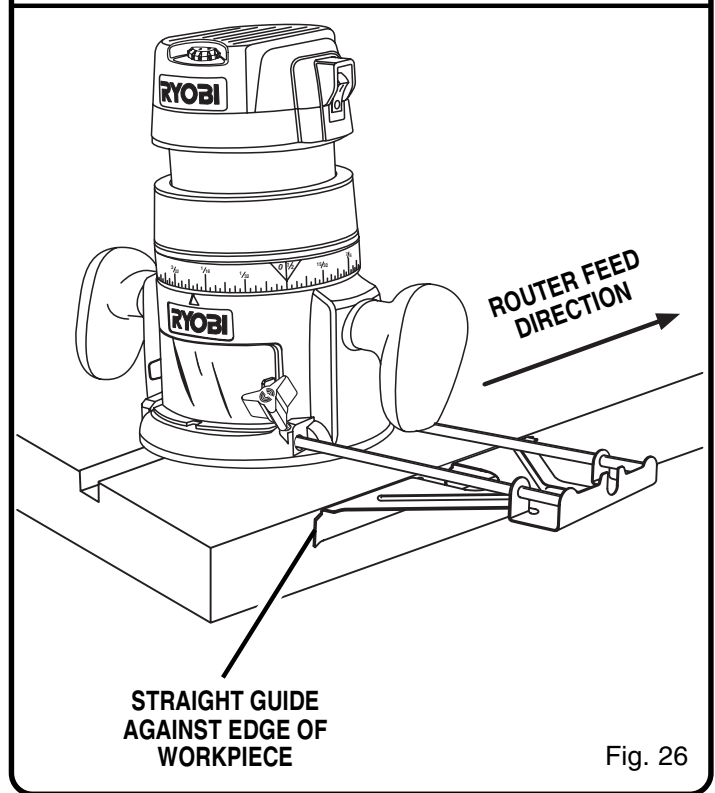
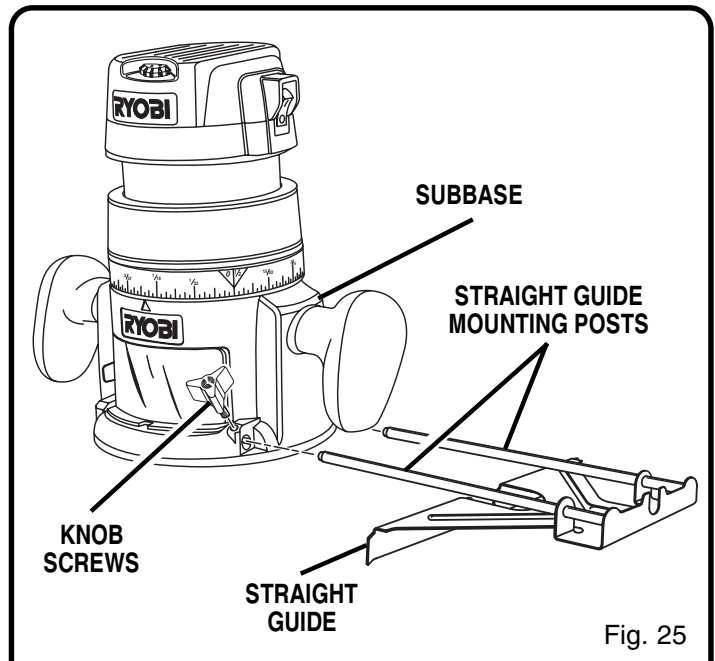

MAINTENANCE

WARNING:

When servicing use only identical Ryobi replacement parts. Use of any other parts may create a hazard or cause product damage.

GENERAL

Avoid using solvents when cleaning plastic parts. Most plastics are susceptible to damage from various types of commercial solvents and may be damaged by their use. Use clean cloths to remove dirt, carbon dust, etc.

WARNING:

Do not at any time let brake fluids, gasoline, petroleum-based products, penetrating oils, etc. come in contact with plastic parts. They contain chemicals that can damage, weaken, or destroy plastic.

Electric tools used on fiberglass material, wallboard, spackling compounds, or plaster are subject to accelerated wear and possible premature failure, as the fiberglass chips and grindings are highly abrasive to bearings, brushes, commutators, etc. Consequently, we do not recommend that this tool be used for extended work on these types of materials. If, however, you do work with any of these materials, it is extremely important that you clean the tool frequently by blowing it with an air jet.

WARNING:

Always wear safety goggles or safety glasses with side shields during power tool operation or when blowing dust. If operation is dusty, also wear a dust mask.

LUBRICATION

All of the bearings in this tool are lubricated with a sufficient amount of high grade lubricant for the life of the unit under normal operating conditions. Therefore, no further lubrication is required.

CUTTERS

Get faster and more accurate cutting results by keeping cutters clean and sharp. Remove all accumulated pitch and gum from cutters after each use.

When sharpening cutters, sharpen only the inside of the cutting edge. Never grind the outside diameter. Be sure when sharpening the end of a cutter to grind the clearance angle the same as originally ground.

COLLET

Dust and chips may collect on the collet from time to time, making it necessary to clean the collet. To do so, remove the collet assembly and wipe it with a clean dry rag. Clean the taper in the shaft in the same manner. Never immerse the collet or end of the shaft in a solvent or in water. Before replacing the collet assembly, put a drop of SAE30 motor oil on the inside of the nut, on the threads of the shaft, and on the taper in the shaft. Replace the collet assembly onto the shaft by hand only. Never tighten the collet nut without a bit in the collet. This action could permanently damage the collet.

ADJUSTING LOCKING ARM TENSION

Over time and with repeated use, the locking arm may become loose. When this occurs, tighten the elastic stop nut slightly. The elastic stop nut should be loose enough so there is some play in the locking arm when it is in the open position. Make sure the motor housing does not move up or down when clamped.

NOTE: Do not over tighten the elastic stop nut. The locking arm should clamp tightly to secure the motor housing.

If the locking arm becomes worn beyond adjustment, a repair kit is available. Please contact your service center to order the appropriate router locking arm repair kit.

ACCESSORIES

The following recommended accessories are included with the tool.

ACCESSORIES

Template Guide Bushing Kit 4070177
Straight Guide 6090080

WARNING:

The use of attachments or accessories not listed could be hazardous.

