

Washer-Extractors

Cabinet Hardmount
B-Series Microcomputer for OPL Models
2 Speed and Variable-Speed
Refer to Page 5 for Model Identification

— Operation/Maintenance —

NOTA: El manual en español aparece después del manual en inglés.

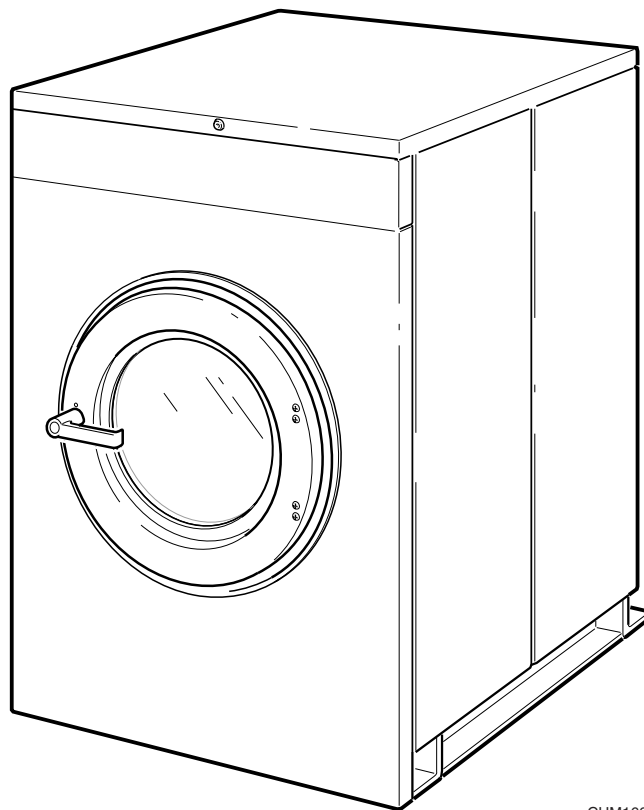

CHM166C

Keep These Instructions for Future Reference.

(If this machine changes ownership, this manual must accompany machine.)



www.comlaundry.com

Part No. F232219R1
November 2005

Table of Contents

Safety Information	3
Explanation of Safety Messages.....	3
Important Safety Instructions	3
Introduction	5
Model Identification	5
Introduction.....	5
Electronic Control Unit.....	5
Control Output Fuse Board.....	6
Harnessing.....	6
Nameplate Location.....	7
Replacement Parts	7
Customer Service.....	7
Summary of Control Outputs and Inputs.....	7
Outputs.....	7
Inputs.....	7
Control Voltage.....	7
Operation	9
Control Panel	9
Summary of Major Features	10
Display Indicators.....	11
Operating Instructions	13
Maintenance	15
Daily	15
Beginning of Day	15
End of Day	15
Weekly.....	16
Monthly.....	16
Quarterly	19
Care of Stainless Steel	20

© Copyright 2005, Alliance Laundry Systems LLC

All rights reserved. No part of the contents of this book may be reproduced or transmitted in any form or by any means without the expressed written consent of the publisher.

Safety Information

Explanation of Safety Messages

Precautionary statements (“DANGER,” “WARNING” and “CAUTION”), followed by specific instructions, are found in this manual and on machine decals. These precautions are intended for the personal safety of the operator, user, servicer and those maintaining the machine.

	DANGER
DANGER indicates the presence of a hazard that will cause severe personal injury, death, or substantial property damage if the danger is ignored.	

	WARNING
WARNING indicates the presence of a hazard that can cause severe personal injury, death, or substantial property damage if the warning is ignored.	

	CAUTION
CAUTION indicates the presence of a hazard that will or can cause minor personal injury or property damage if the caution is ignored.	

Additional precautionary statements (“IMPORTANT” and “NOTE”) are followed by specific instructions.

IMPORTANT: The word “IMPORTANT” is used to inform the reader of specific procedures where minor machine damage will occur if the procedure is not followed.

NOTE: The word “NOTE” is used to communicate installation, operation, maintenance or servicing information that is important but not hazard related.

Important Safety Instructions

	WARNING
To reduce the risk of fire, electric shock, serious injury or death to persons when using your washer, follow these basic precautions:	
W023	

1. Read all instructions before using the washer.
2. Refer to the GROUNDING INSTRUCTIONS in the INSTALLATION manual for the proper grounding of the washer.
3. Do not wash textiles that have been previously cleaned in, washed in, soaked in, or spotted with gasoline, kerosene, waxes, cooking oils, dry-cleaning solvents, or other flammable or explosive substances as they give off vapors that could ignite or explode.
4. Do not add gasoline, dry-cleaning solvents, or other flammable or explosive substances to the wash water. These substances give off vapors that could ignite or explode.
5. Under certain conditions, hydrogen gas may be produced in a hot water system that has not been used for two weeks or more. HYDROGEN GAS IS EXPLOSIVE. If the hot water system has not been used for such a period, before using a washing machine or combination washer-dryer, turn on all hot water faucets and let the water flow from each for several minutes. This will release any accumulated hydrogen gas. The gas is flammable; do not smoke or use an open flame during this time.
6. Do not allow children to play on or in the washer. Close supervision of children is necessary when the washer is used near children. This is a safety rule for all appliances.
7. Before the washer is removed from service or discarded, remove the door to the washing compartment.
8. Do not reach into the washer if the wash drum is moving.

Safety Information

9. Do not install or store the washer where it will be exposed to water and/or weather.
10. Do not tamper with the controls.
11. Do not repair or replace any part of the washer, or attempt any servicing unless specifically recommended in the user-maintenance instructions or in published user-repair instructions that the user understands and has the skills to carry out.
12. To reduce the risk of an electric shock or fire, DO NOT use an extension cord or an adapter to connect the washer to the electrical power source.
13. Use washer only for its intended purpose, washing textiles.
14. ALWAYS disconnect the washer from electrical supply before attempting any service. Disconnect the power cord by grasping the plug, not the cord.
15. Install the washer according to the **INSTALLATION INSTRUCTIONS**. All connections for water, drain, electrical power and grounding must comply with local codes and be made by licensed personnel when required.
16. To reduce the risk of fire, textiles which have traces of any flammable substances such as vegetable oil, cooking oil, machine oil, flammable chemicals, thinner, etc. or anything containing wax or chemicals such as in mops and cleaning cloths, must not be put into the washer. These flammable substances may cause the fabric to catch on fire by itself.
17. Do not use fabric softeners or products to eliminate static unless recommended by the manufacturer of the fabric softener or product.
18. Keep washer in good condition. Bumping or dropping the washer can damage safety features. If this occurs, have washer checked by a qualified service person.
19. Replace worn power cords and/or loose plugs.
20. Be sure water connections have a shut-off valve and that fill hose connections are tight. CLOSE the shut-off valves at the end of each wash day.
21. Loading door **MUST BE CLOSED** any time the washer is to fill, tumble or spin. **DO NOT** bypass the loading door switch by permitting the washer to operate with the loading door open.
22. Always read and follow manufacturer's instructions on packages of laundry and cleaning aids. Heed all warnings or precautions. To reduce the risk of poisoning or chemical burns, keep them out of the reach of children at all times (preferably in a locked cabinet).
23. Always follow the fabric care instructions supplied by the textile manufacturer.
24. Never operate the washer with any guards and/or panels removed.
25. **DO NOT** operate the washer with missing or broken parts.
26. **DO NOT** bypass any safety devices.
27. Failure to install, maintain, and/or operate this washer according to the manufacturer's instructions may result in conditions which can produce bodily injury and/or property damage.

NOTE: The WARNINGS and IMPORTANT SAFETY INSTRUCTIONS appearing in this manual are not meant to cover all possible conditions and situations that may occur. Common sense, caution and care must be exercised when installing, maintaining, or operating the washer.

Any problems or conditions not understood should be reported to the dealer, distributor, service agent or the manufacturer.

Introduction

Model Identification

Information in this manual is applicable to these models:

HC20BN2	HC50BN2	HC80BNV	SC40BN2	SC60BNF	UC30BN2	UC60BN2
HC30BN2	HC60BN2	SC20BN2	SC50BN2	SC80BNV	UC40BN2	UC60BNF
HC40BN2	HC60BNF	SC30BN2	SC60BN2	UC20BN2	UC50BN2	UC80BNV

Introduction

The “B” electronic control is composed of the electronic control unit and the control fuse board with wiring harness. Only an authorized person should look inside the machine. First TURN OFF POWER, open lid and remove any cover present. Make sure door lock circuit has fully discharged. The door unlock capacitor can retain high electrical charge, even when the machine’s electrical inputs are disconnected, until it has discharged. Some machines are equipped with an “amber” indicator light facing upward in the control compartment. If this is on, wait until it goes off (indicating when high voltage in the door lock circuit has discharged).

Electronic Control Unit

This portion of the control contains the “intelligence” – the micro-controller and the miscellaneous components on the printed circuit (PC) board. The board has a metal cover, which MUST be in place at all times during machine operation. Operation of the machine without this cover installed will void the warranty.

The control unit monitors and responds to input, gives information about the status of the washer and monitors and responds to inputs from the user interface (keypad). The control provides signals to the control output unit, which in turn operates the components that control the machine functions. This is located behind the machine control panel.

Introduction

Control Output Fuse Board

This portion of the control contains the power supply for the control unit, and also the switching devices which power the components in the machine, all of which are on the output PC board. The switching devices are controlled by the control unit, and are solid state.

Harnessing

Wiring harnesses are modular – harnesses common to various configurations are similar, while those specific to a certain configuration can be added. There are harnesses for inputs to the control unit, for outputs from the control power/output unit to the machine components, and for the main incoming power to the control power/output unit.

Nameplate Location

The nameplate is located at the rear of the machine and inside door. Always provide the machine's serial number and model number when ordering parts or when seeking technical assistance.

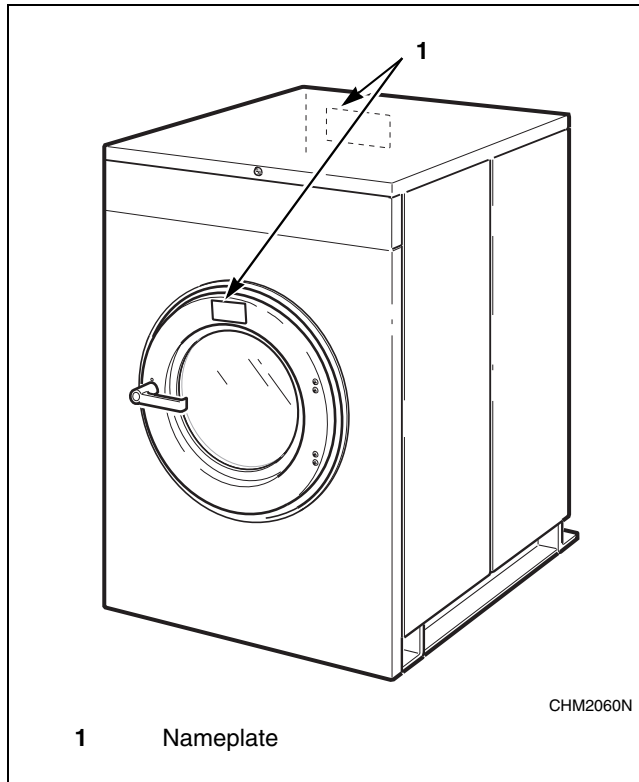

Figure 1

Replacement Parts

If literature or replacement parts are required, contact the source from whom the machine was purchased or contact Alliance Laundry Systems at (920) 748-3950 for the name and address of the nearest authorized parts distributor.

Customer Service

For technical assistance, call: (920) 748-3121 Ripon, Wisconsin.

Summary of Control Outputs and Inputs

Outputs

General outputs provide signals to operate the following components.

1. Hot Fill Valve
2. Cold Fill Valve
3. Drain Valve (normally open)
4. Door Lock Solenoid Coil
5. Door Unlock Solenoid Coil
6. Supply 1 (detergent)
7. Supply 2 (bleach)
8. Supply 3 (sour/softener)
9. Supply 4
10. Supply 5 or Optional 3rd (auxiliary) Fill Inlet (governed by the configuration settings)
11. Optional Heat

For standard models, the components for outputs shown as “optional” will not be populated on the output printed circuit board.

AC outputs are solid state outputs that operate either 120 Volt AC or 220 Volt AC (nominal voltage) components, depending on the control voltage configuration. Outputs are fused appropriately.

Inputs

1. Low Water Level
2. Medium Water Level
3. High Water Level
4. Door
5. Temperature Signal (only for machines with heat option)

Control Voltage

The control power supply can be configured to operate on 110 Volt AC nominal RMS input voltage 50/60 Hertz, OR 220 Volt AC nominal RMS input voltage 50/60 Hertz.

Introduction

Model Number Familiarization Guide	
Sample Model Number: *C60BN2OU60001	
*C	Model Number Prefix
60	Washer-Extractor Capacity (pounds dry weight of laundry)
B	Type of Electrical Control (B = B - Control)
N	Actuation (N = Non-Coin)
2	Washer-Extractor Speed Capability (2 = 2 speed)
O	Electrical Characteristics
U6	Design Series
0001	Option Identification (varies from machine to machine)

* Denotes Brand

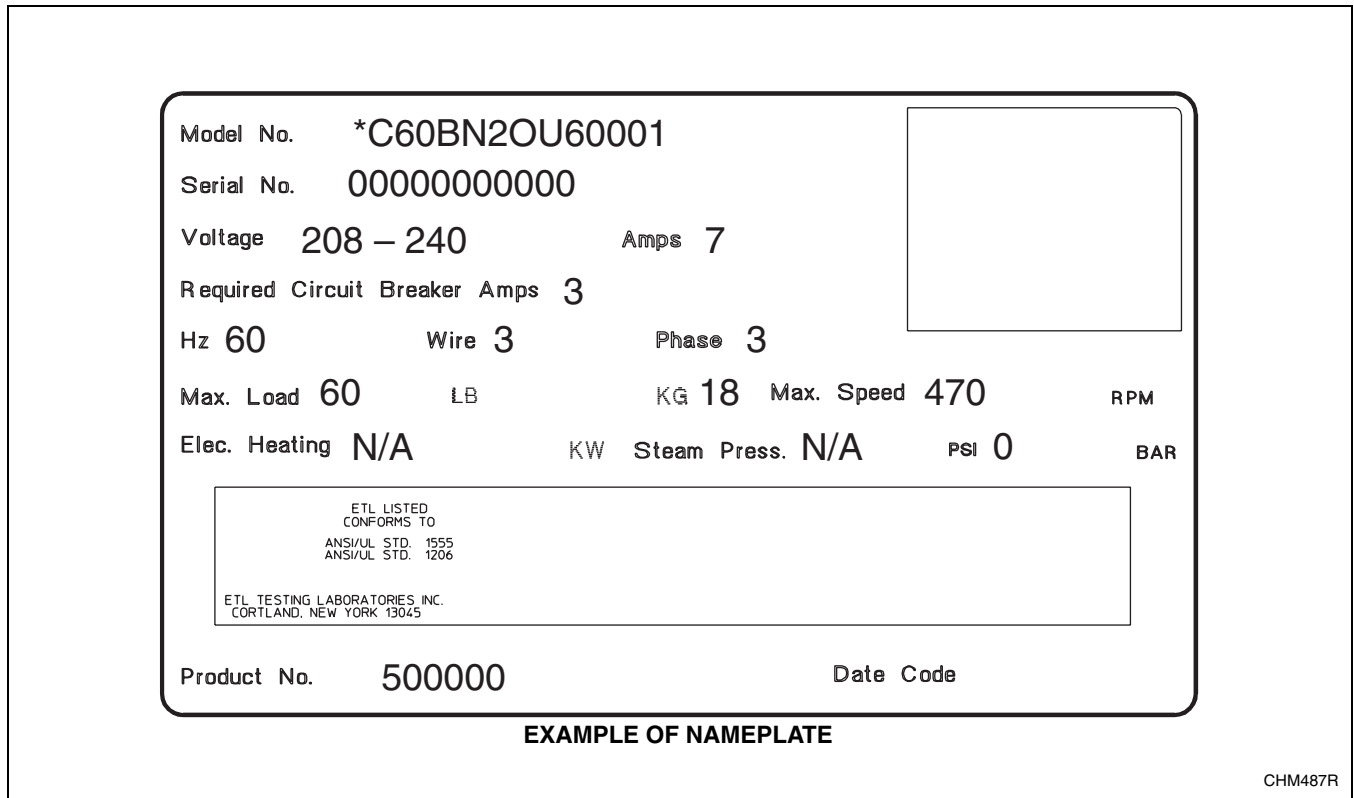

Figure 2

Operation

Control Panel

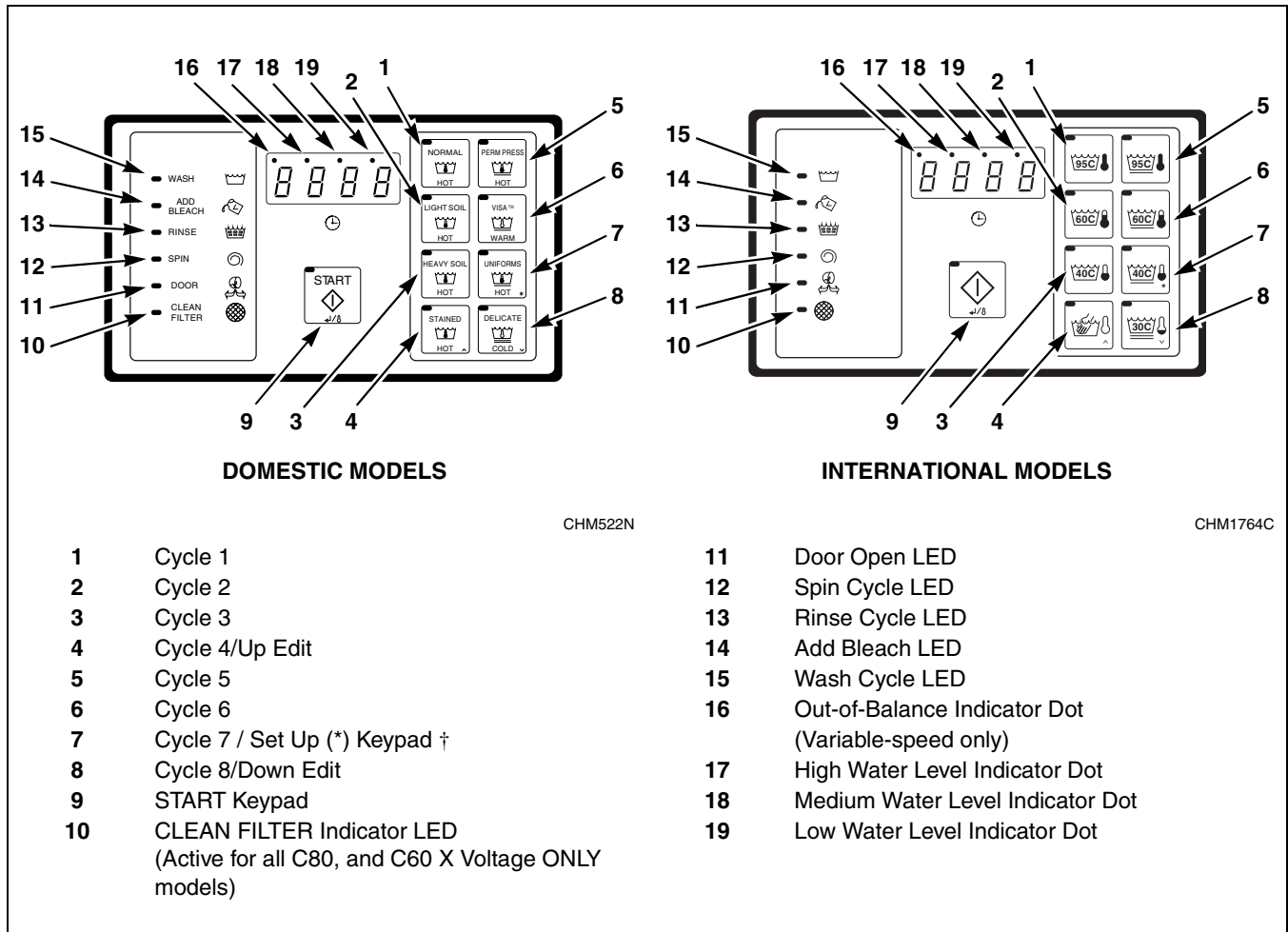

Figure 3

†Set Up(*) keypad is used in cycle programming in program mode. Refer to Programming Manual.

Operation

Summary of Major Features

LED for Machine Functions	LED lights inform operator which machine function is active. DOOR LED lights to inform operator that the door can be opened or should be closed. The circle LED indicates that the filter needs cleaning.
Water Levels	Three (3) – Contacts from pressure switch (test cycle)
Main LED display	4 digit LED display counts down cycle time. Lights in LED display indicate out-of-balance conditions and, in test cycle, water level. Display shows “01” as the final spin time.
Cycle selection keypads	Eight (8) cycle select keypads with LED indicator to show selected cycle. LED lights will flash to prompt user to press a keypad.
START keypad	Press to start a cycle after cycle selection is made. LED light will flash to prompt user to press keypad.
Test Cycle with “Advance”	For troubleshooting. Advance rapidly through test cycle by pressing the UP keypad. Refer to PROGRAMMING manual.
Fill Temperatures	Cold, Hot, Warm
Supplies	Five (5) or Four (4) with extra fill value option.
Agitation Types	Normal or Gentle
Drain Options	Normally open gravity drain
Cycle Count	0 to 9999 cannot be reset – Rolls over after 9999
Rapid Advance Mode	Rapid Advance can be enabled or disabled. Enabled allows user to advance through a cycle. Refer to the Programming Manual.

Table 1

Display Indicators

Table 2 lists the various displays and what they mean. The operator should become familiar with these machine displays.

Display	Meaning
tES _t	Diagnostic test cycle selected or enabled
SPIn	Spin (extract) step
SUP1	Supply signal 1 (“S1” output), normally detergent
SUP2	Supply signal 2 (“S2” output), normally bleach
SUP3	Supply signal 3 (“S3” output), normally softener
SUP4	Supply signal 4
SUP5	Supply signal 5
SdLY	Spin coast (motor coasts after high speed extract)
CFIL	Cold Fill
HFIL	Hot Fill
bFIL	Warm Fill (cold + hot)
bLCH	Control will also light “add bleach” indicator
PASS	Variable-speed ONLY – balance “PASS” condition; shows in “test” cycle only
FAIL	Variable-speed ONLY – balance “FAIL” condition; shows in “test” cycle only
bAL?	Variable-speed ONLY – meaning: “Do you wish to enter balance detection test routine?”
CY__	Cycle number (followed by a space and number 1 through highest cycle number)
nor \bar{n}	Normal agitation selected
gEnt	Gentle (reduced) agitation selected
SPn1	Variable-speed ONLY – low spin speed (the lower of 2 spin speeds)
SPn2	Variable-speed ONLY – high spin speed (the higher of 2 spin speeds)
For	Wash speed forward (during test cycle)
rEv	Wash speed reverse (during test cycle)
dIS _t	Variable-speed ONLY – distribution speed (during test cycle)
LO	Low water level
nEd	Medium water level
HI	High water level
CEL	Display all temperatures in degrees Celsius
FAR	Display all temperatures in degrees Fahrenheit
___C	The first 3 digits are reserved for temperature reading, C indicates “degrees Celsius”

Table 2 (Continued)

Operation

Table 2 (Continued)

Display	Meaning
___F	The first 3 digits are reserved for temperature reading, F indicates “degrees Fahrenheit”
FILL	“Fill error” – machine did not fill to programmed water level within 10 minutes; also displays during Rapid Advance Mode.
door	“Door” opened during cycle
SHUt/door	Machine user must “shut door” of the washer to allow the cycle to begin
CAnt/OPEn	Control cannot unlock the door
USH1	“Wash 1” segment
USH2	“Wash 2” segment
USH3	“Wash 3” segment
USH4	“Wash 4” segment
rIn1	“Rinse 1” segment
rIn2	“Rinse 2” segment
rIn3	“Rinse 3” segment
rIn4	“Rinse 4” segment (final rinse)
donE	Cycle has concluded
drAI	Drain selected for segment; also indicates in drain step during 2 speed version test cycle or during Rapid Advance Mode.
----	Flashes for a period of time (for safety) after power up while keeping outputs OFF
Adv	Machine set up for Rapid Advance
noAd	Machine is not set up for Radid Advance
Erdn	Drain count error (depending on model)
Erfl	Fill error count (depending on model)
E Pr	The number of times power has been interrupted during a cycle (will display in certain models)
CyC	Cycle counter

Operating Instructions

1. Turn on main power source (circuit breaker) with right hand.
2. With left hand, push and hold white rocker button. Refer to *Figure 4*.
3. Push button and turn handle clockwise to open. Refer to *Figure 4*.

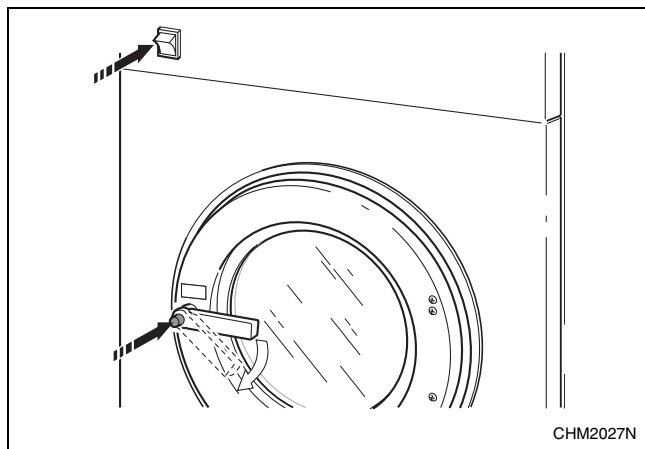

Figure 4

4. Load to capacity whenever possible. **DO NOT OVERLOAD.** Refer to *Figure 5*.

NOTE: Underloading can cause out-of-balance conditions that can shorten machine life.

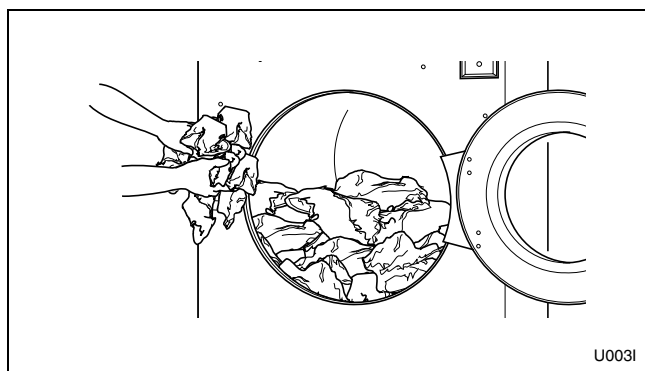

Figure 5

5. Close door and turn handle counterclockwise until button pops out. Refer to *Figure 6*.

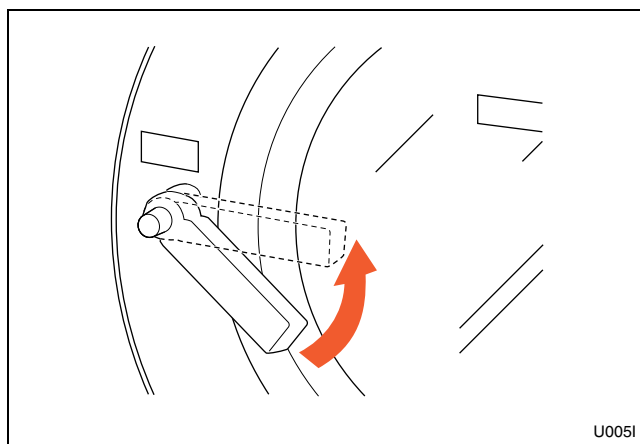

Figure 6

6. The default wash cycle will display.

NOTE: Perm Press Hot is the default cycle if none is selected.

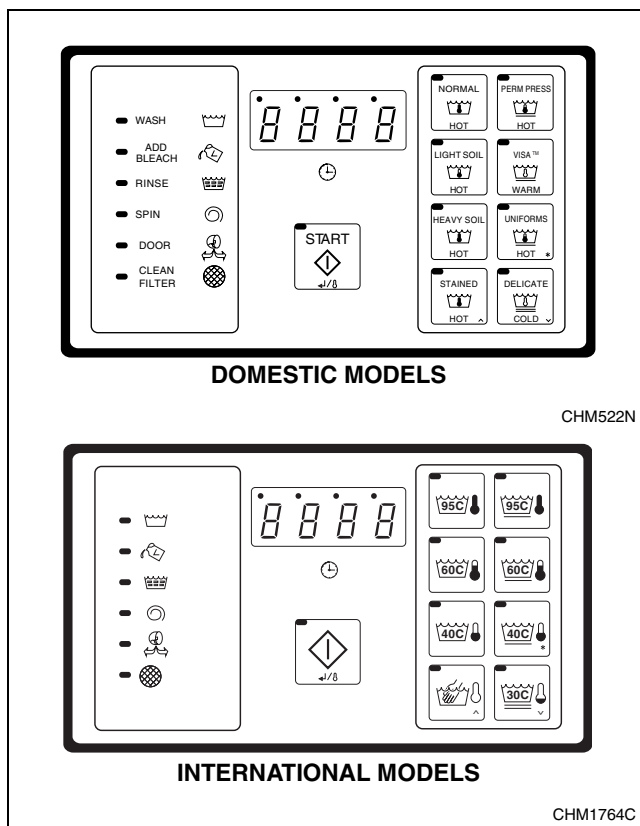

Figure 7

Operation

7. If desired, select a different cycle at this point. The LED indicator for that cycle will light.
8. Add liquid and/or powder supplies to supply dispenser. Refer to *Figure 8*.
 - a. Add detergent to compartment 1.
 - b. Add softener to compartment 3.

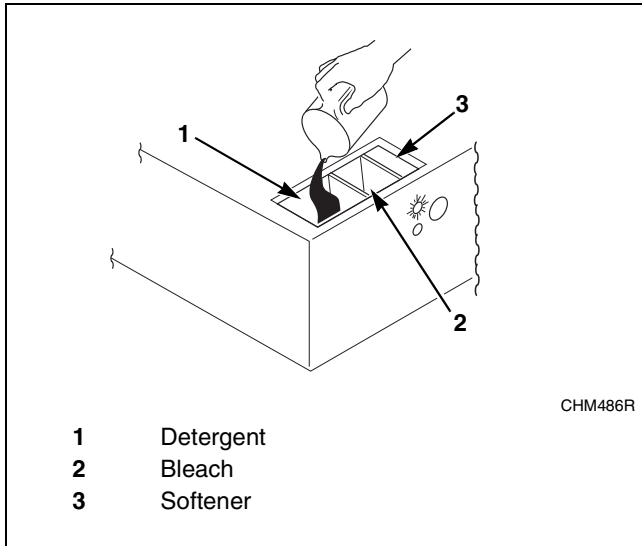



Figure 8

9. **When applicable**, add bleach to compartment 2 when the ADD BLEACH LED is lit.
10. Press the desired wash cycle keypad if none is selected.
11. Press the START keypad.
12. During first fill, the desired wash cycle can be changed. After first fill has ended, the wash cycle active at that moment remains the chosen wash cycle.
13. When cycle is complete, display shows “donE”.

Maintenance

	WARNING
Sharp edges can cause personal injury. Wear safety glasses and gloves, use proper tools and provide lighting when handling sheet metal parts.	
W366R1	

IMPORTANT: Replace all panels that are removed to perform service and maintenance procedures. Do not operate the machine with missing guards or with broken or missing parts. Do not bypass any safety devices.

Daily

IMPORTANT: Door lock should be checked daily to ensure proper operation. Also check that all safety and instruction stickers are on the machine. Any missing or illegible safety instructions stickers should be replaced immediately.

Beginning of Day

1. Inspect water inlet valve hose connections on the back of the machine for leaks.
2. Inspect steam hose connections for leaks (where applicable).
3. Verify that insulation is intact on all external wires and that all connections are secure. If exposed wire is evident, call a service technician.

4. Check door interlock before starting operation:
 - a. Attempt to start the machine with the door open. The machine should not start with the door open.
 - b. Close the door without locking it and attempt to start the machine. The machine should not start with the door unlocked.
 - c. Close and lock the door, and start a cycle. Attempt to open the door while the cycle is in progress. The door should not open.

If the door lock and interlock are not functioning properly, call a service technician.

End of Day

1. Clean the door gasket of residual detergent and all foreign matter.
2. Clean automatic supply dispenser lid and general area. Flush dispenser with clean water.
3. Clean the machine's top, front and side panels with mild detergent. Rinse with clean water.
4. Leave loading door open at the end of each day to allow moisture to evaporate.

NOTE: Unload the machine promptly *after each completed cycle* to prevent moisture buildup. Leave loading door open *after each completed cycle* to allow moisture to evaporate.

Maintenance

Weekly

1. For variable-speed models only, clean the AC drive box filter(s) weekly or more frequently as needed:

NOTE: If fan filter service indicator light is on, fan filter must be cleaned immediately to prevent possible damage. Thermostat automatically resets after drive compartment cools down. LED will then extinguish after cycle run.

IMPORTANT: If filter indicator is ignored, repeated resets might shorten life of drive. Clean filter regularly to avoid indicator prompt.

- a. Open the top cover.
- b. Grasp the filter handle and pull straight up to remove filter.
- c. Wash the filter with warm water and allow filter to air-dry. As an alternative, the filter may be vacuumed clean.

IMPORTANT: The control module cover and fan filter must be in place for the fan to properly cool the AC inverter drive. Failure to observe this warning will void the warranty and could lead to expensive AC inverter drive repair.

2. Check the machine for leaks.
 - a. Start an unloaded cycle to fill the machine.
 - b. Verify that door and door gasket do not leak.
 - c. Verify that the drain valve is operating and that the drain system is free from obstruction. If water does not leak out during the first wash segment, the drain valve is closed and functioning properly.

Monthly

NOTE: Disconnect power to the machine at its source before performing the monthly maintenance procedures.

1. Use the following procedures to determine if V-belt(s) require replacement or adjustment. Call a qualified service technician in either case.
 - a. Check V-belt(s) for uneven wear and frayed edges.
 - b. Verify pulley alignment by placing a straightedge across both pulley faces. The straightedge should make contact with the pulleys in four places. Refer to *Figure 9*.

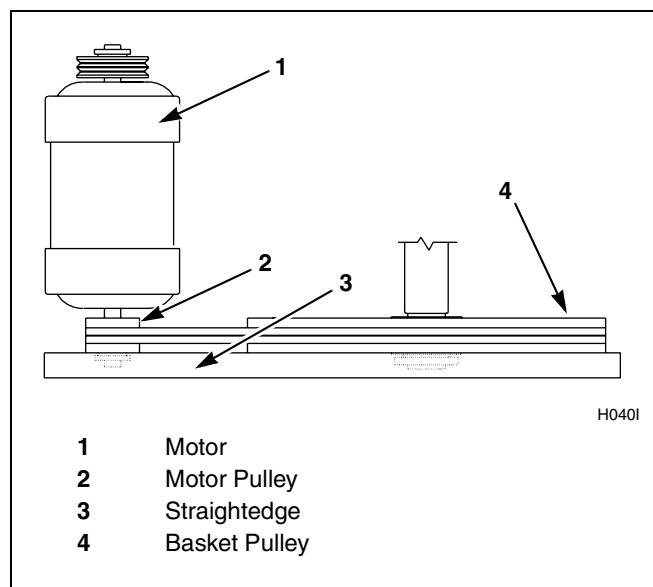

Figure 9

c. For flat-pulley drive systems, verify allowable distance of belt from edge of pulley. Refer to *Table 3* below.

Flat-Pulley Alignment	
Model	Allowable Distance from Edge
20	3/32 in. (2 mm)
25	3/32 in. (2 mm)
30	3/32 in. (2 mm)
40	3/32 in. (2 mm)
50 – 60	3/8 in. (10 mm)

Table 3

d. For variable-speed models only, verify that V-belts are properly tensioned by applying a set force to the belts and measuring the deflection to determine the belt tension. Refer to *Table 4* for the acceptable belt's tension ranges. Belt tension measurements should be taken as close to the center of the belt span as possible. Refer to *Figure 10*.

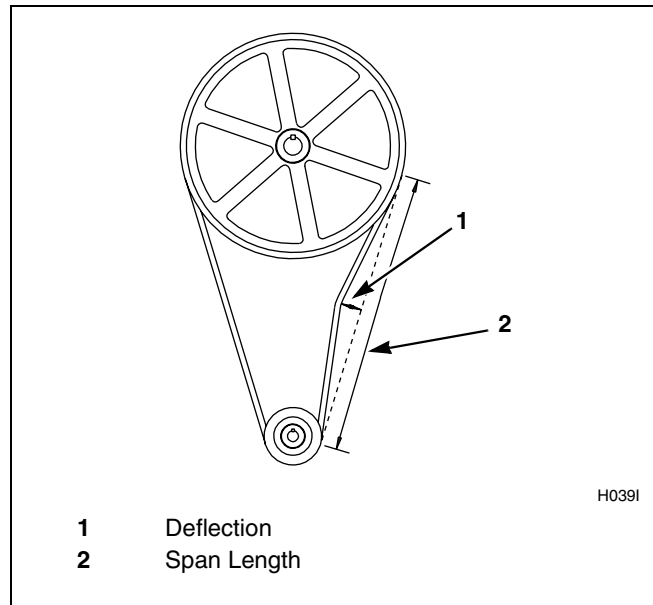

Figure 10

Belt Tension Testing for Variable-Speed Models				
Model	Belt	Belt Span	Deflection Range	Force Min – Max
35, 40	Motor-Basket	16.9 in. (428 mm)	5/16 – 11/32 in. (7.9 – 8.7 mm)	6.1 – 7.4 lbs. (27 – 33 N)
50, 60	Motor-Basket	16.8 in. (426 mm)	9/32 – 5/16 in. (7.1 – 7.9 mm)	6.1 – 7.4 lbs. (27 – 33 N)
80	Motor-Basket Single Belt	22.1 in. (561 mm)	15/32 – 1/2 in. (11.9 – 12.7 mm)	4.9 – 7.3 lbs. (21.8 – 31.5 N)
80	Motor-Basket Banded Belt	22.1 in. (561 mm)	7/32 – 1/4 in. (5.08 – 6.35 mm)	23 – 26 lbs. (102.3 – 115.6 N)

Table 4

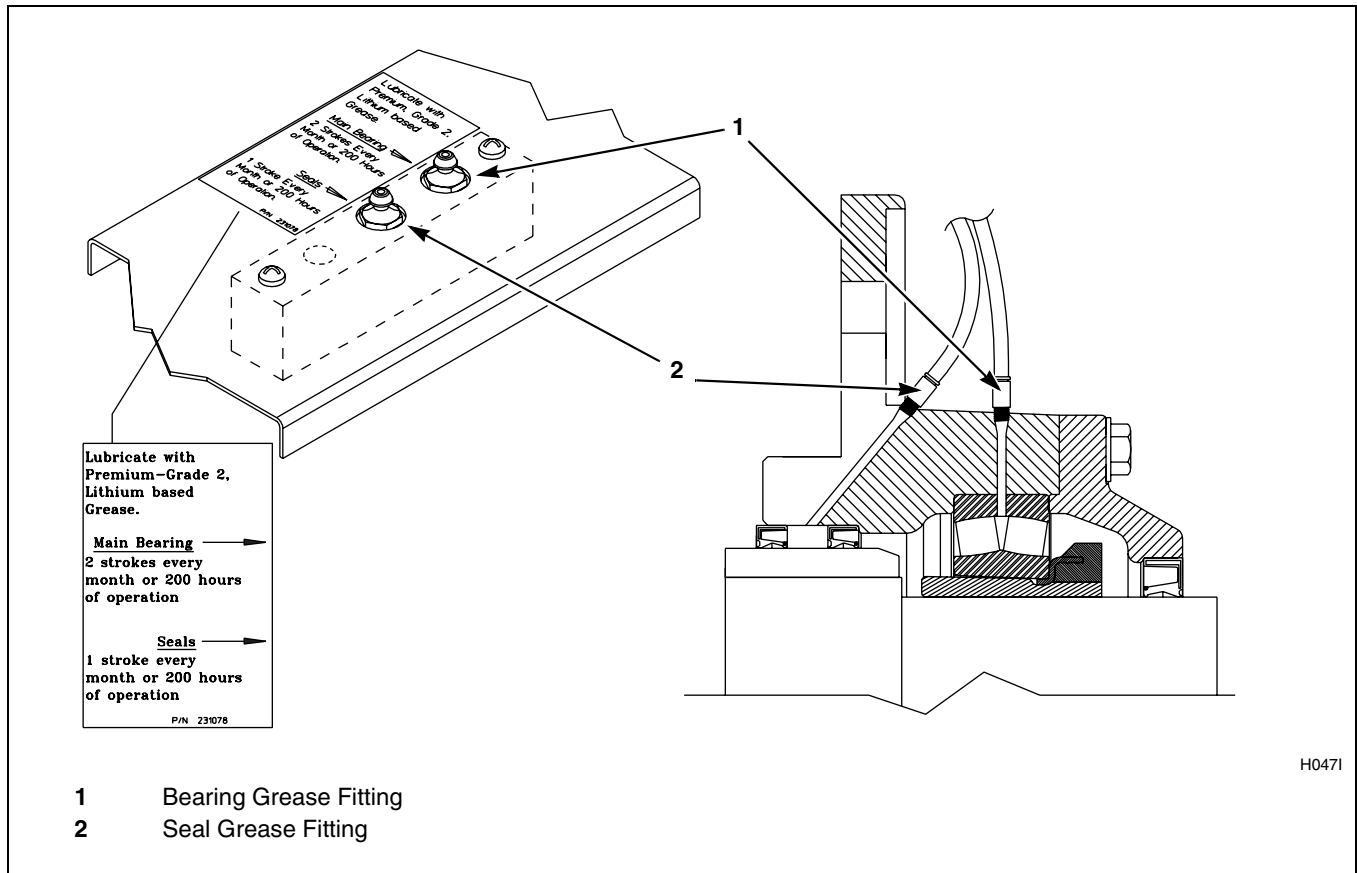

Figure 11

2. **For 80 pound capacity models only**, lubricate bearings and seals each month OR after every 200 hours of operation. Refer to *Figure 11*.
 - a. Use a premium-grade lithium-based #2 grease. Never mix two types of grease, such as petroleum and silicone.

- b. Pump the grease gun slowly, permitting only the following number of strokes:

- Bearing grease fitting, 2 strokes
- Seal grease fitting, 1 stroke

Do not pump the grease gun until grease comes out of the bearing housing. This can result in overlubrication, causing damage to bearings and seals.

3. Remove back panel and check overflow hose and drain hose for leaks.
 4. Unlock the hinged lid and check the supply dispenser hoses and hose connections.
 5. Clean inlet hose filter screens:
 - a. Turn water off and allow valve to cool, if necessary.
 - b. Unscrew inlet hose and remove filter screen.
 - c. Clean with soapy water and reinstall. Replace if worn or damaged.
 6. Tighten motor mounting bolt locknuts and bearing bolt locknuts, if necessary.
 7. Use compressed air to clean lint from motor.
 8. Clean interior of machine, both basket and shell, by wiping with a water-soaked sponge or cloth.
 9. Use compressed air to ensure that all electrical components are free of moisture and dust.
 10. **For variable-speed models only**, clean AC drive cooling fan blades monthly (more often if required by the condition of the air).
 - a. Open the top cover and remove the control module cover.
 - b. Gently wipe the fan blades clean with a dry cloth.
4. Check all painted surfaces for exposed metal. (Matching paint is available from the manufacturer.)
 - If bare metal is showing, paint with primer or solvent-based paint.
 - If rust appears, remove it with sandpaper or by chemical means.

Then paint with primer or solvent-based paint.
 5. Clean customer-supplied steam filter, where applicable. Refer to *Figure 12*.
 - a. Turn off steam supply and allow time for the valve to cool.
 - b. Unscrew cap.
 - c. Remove element and clean.
 - d. Replace element and cap.

Quarterly

NOTE: Disconnect power to the machine before performing the quarterly maintenance procedures.

1. Tighten door hinges and fasteners, if necessary.
2. Tighten anchor bolts, if necessary.
3. Verify that the drain motor shield is in place and secure, if so equipped.

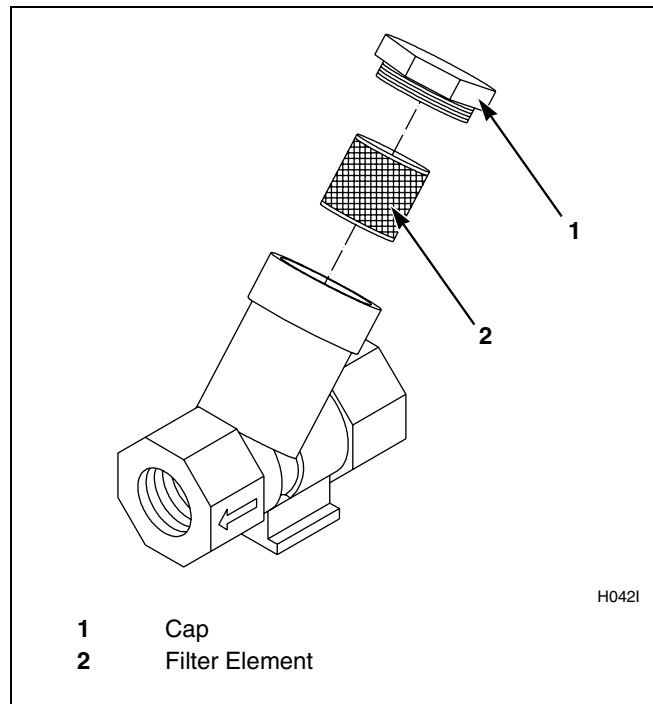

Figure 12

Maintenance

Care of Stainless Steel

- Remove dirt and grease with detergent and water. Thoroughly rinse and dry after washing.
- Avoid contact with dissimilar metals to prevent galvanic corrosion when salty or acidic solutions are present.
- Do not allow salty or acidic solutions to evaporate and dry on stainless steel. Wipe clean of any residues.
- Do not leave sanitizers or sterilizing solutions on stainless steel equipment for prolonged periods of time.
- When an external chemical supply is used, ensure no siphoning of chemicals occurs when the washer-extractor is not in use. Highly concentrated chemicals can cause severe damage to stainless steel and other components with the machine. Damage of this kind is not covered by the manufacturer's warranty. Locate the pump below the washer-extractor's injection point to prevent siphoning of chemicals into the machine.
- If the stainless steel appears to be rusting, the source of the rust may actually be a foreign piece of iron or steel part not made of stainless steel, such as a nail or screw contacting the stainless steel surface. Tip: Paint all carbon steel parts with a heavy protective coating. Stainless steel fasteners should be used whenever possible.