



EVERFOCUS

1/3" Color Rugged Dome Camera Operation Instructions

Model No. **EHD300**

Please read this manual first for correct installation and operation. This manual should be retained for future reference. The information in this manual was current when published. The manufacturer reserves the right to revise and improve its products. All specifications are therefore subject to change without notice.

PRECAUTIONS

1. Do not install the camera near electric or magnetic fields.

Install the camera away from TV, radio transmitter, magnet, electric motor, transformer, audio speakers since the magnetic fields generate from above devices will distort the video images.

2. Never disassemble the camera nor put impurities in it.

Disassembly or impurities may result in trouble or fire.

3. Never face the camera toward the sun.

Direct sunlight or severe ray may cause fatal damage to sensor and internal circuit.

4. Keep the power cord away from water and liquid.

Touching the wet power cord may result in electric shock.

5. Cleaning

Do not touch the surface of sensor by hand directly. Use a soft cloth to remove the dirt from the camera body. Use lens tissue or a cotton swab and ethanol to clean the sensor and the camera lens.

6. Do not operate the camera beyond the specified temperature, humidity or power source ratings.

Use the camera at temperatures within $-10^{\circ}\text{C} \sim 50^{\circ}\text{C}/14^{\circ}\text{F} \sim 122^{\circ}\text{F}$ and humidity between 20%~ 80%. The input power source is 12VDC/24VAC.

PREFACE

The most technically advanced EHD series are the newest vandal-resistant Color Rugged Dome Camera from EverFocus Electronics. The Color Rugged Dome Camera can withstand a blow from a 10-pound sledgehammer and has a built-in heater that allows for operation in low temperatures. It is perfect for all high-profile crime-prone applications such as building entrances, retail stores, and shopping malls. EHD series are unquestionably one of the world's toughest cameras and is your best choice for vandal resistance.

FEATURES

- 1/3" SONY Super HAD color CCD pick up device for more than 520 TV lines of horizontal resolution
- Low light sensitivity of 0.4 lux/F=1.2 is achieved by using 1/3" SONY Super HAD interline transfer color CCD
- The electronic shutter and AGC allow the camera to be used in environment with varying light levels
- 12VDC/24VAC switches automatically power supply
- S/N Ratio reaches 48 dB or more
- Built-in Vari-focal lens
- Flickerless, Mirror, AGC and D/N functions ON/OFF switchable
- With manual Pan/Tilt mechanism
- Rugged dome designed for vandal proof
- Rugged Dome designed with 3-axis which provides the best installation for ceiling and wall mount
- IP66 weatherproof

INSTALLATION

1. Loosen the 4 fix screws on the housing cover by using the attached wrench (Figure 1).

Please pay attention not to damage the lens.

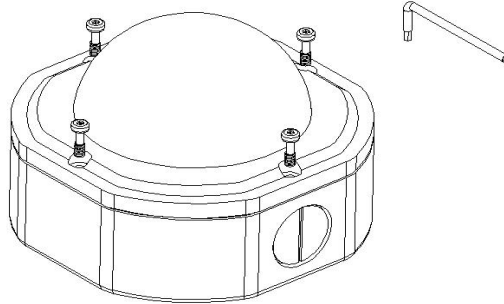

Figure 1

2. Remove the camera.

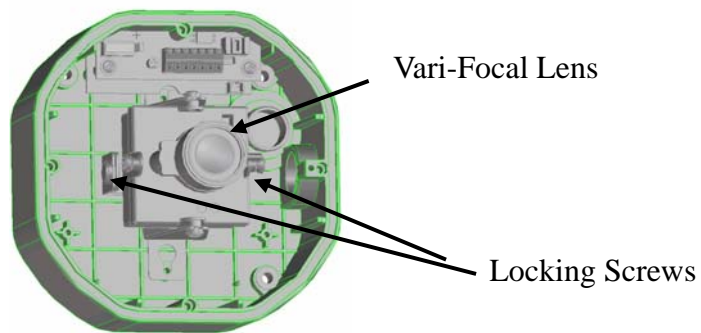

Figure 2

To remove the camera, first unplug the wire connection on the back of the camera. Then loosen the 2 locking screws on the camera base, push the camera base to the right (toward heater direction, as shown in Figure 2), remove the camera from the mounting base.

Reinstall the camera and the cable while the base mounting is completed.

3. Mounting the base.

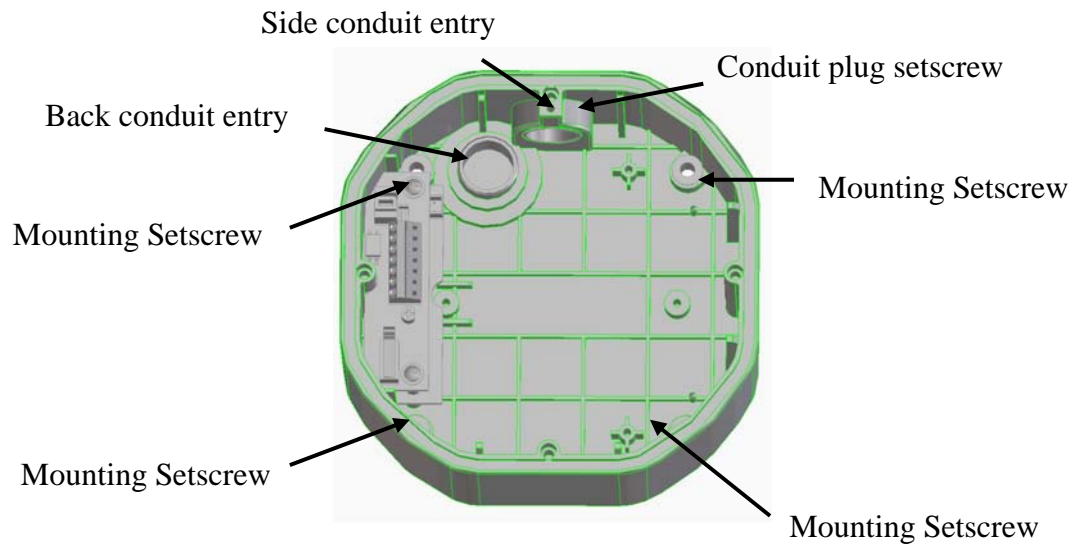
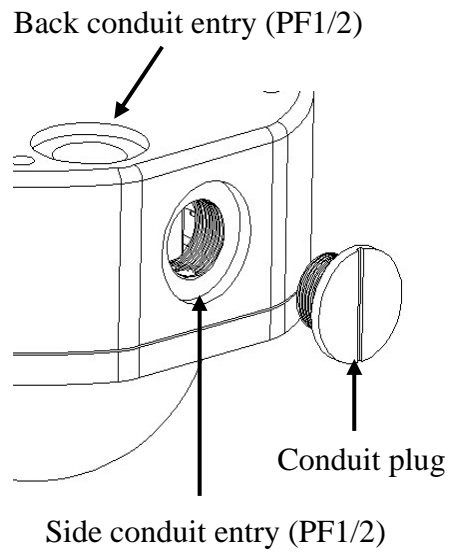

Figure 3

Attach the base to the wall or ceiling, fix the base by the 4 setscrews attached in the accessory pack. Please make sure if the mounting is strengthened enough to support it, if not, please reinforce the mounting according to the environment.

Note: The diameter of the screw hole is ϕ 4.7mm.



The camera comes with a conduit plug pre-installed in the PF 1/2 conduit entry on the side. The screw can be removed and installed in the back conduit entry. Loosen the conduit plug setscrew (as shown in Figure 4) before removing the conduit plug.

Figure 4

Caution: To prevent moisture leaking into the housing, apply an appropriate gasket or sealant around the conduit connection.

4. Wire Connection

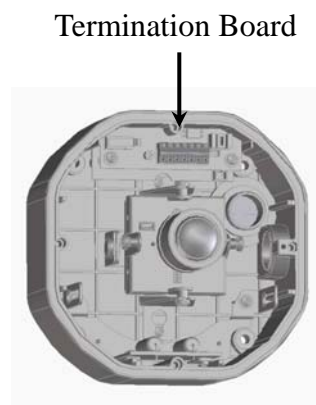

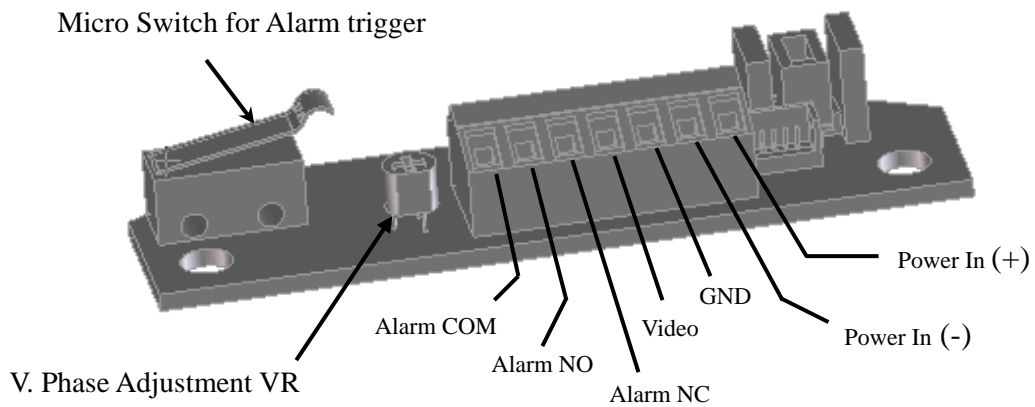

Figure 5

Connect the power supply cable (12VDC/24VAC), video output and alarm output to the proper connectors shown as Figure 5.

The V. Phase adjustment screw is located on the termination board. The vertical phase may require adjustment to synchronize the vertical phase of the camera with other camera in the system when it is to be used in the line-lock sync mode. Make the adjustment when the vertical phase of the camera does not match with other cameras.

5. View Angle Adjustment

The camera can be rotated 360° horizontally, 140° vertically and 60° 3rd axis view angles (as shown in Figure 6). Adjust the proper camera view angle as needed. If a vari-focal lens is used, you may adjust the focus and zoom of the lens to bring the object in focus. Be sure to loosen the locking screws on the lens before you make adjustment.

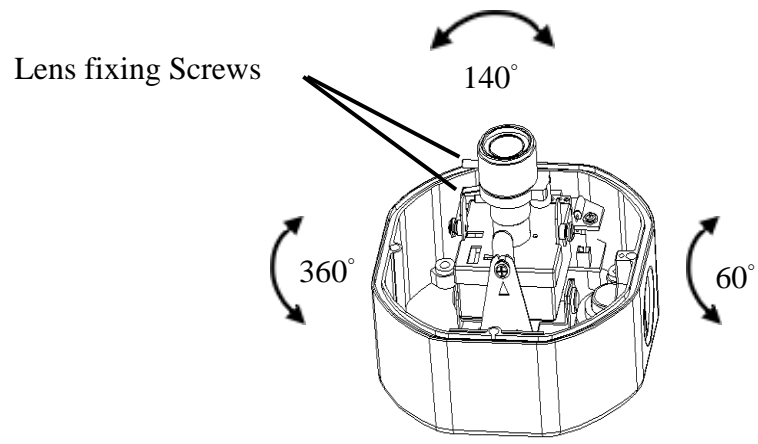
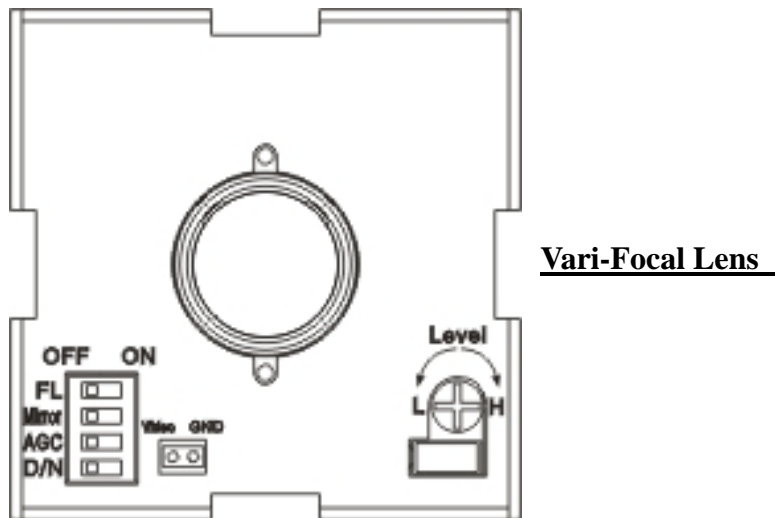

Figure 6

DIP SWITCH FUNCTION



FL (Flickerless Function) ON/OFF

When picture flicker fiercely, turn FL on, then the camera will stabilize the speed of electronic shutter at 1/100(NTSC) or 1/120(PAL) automatically, and reduce the flicker immediately.

The default setting is OFF.

Mirror ON/OFF

Mirror ON: Set a horizontal image inversion.

Mirror OFF: Disable the inversion.

The default setting is OFF.

AGC (Automatic Gain Control) OFF/ON

AGC ON: The sensitivity increases automatically when light is low.

AGC OFF: A low-noise picture is obtained under a low light condition.

The default setting is ON.

D/N (Day/Night) ON/OFF

D/N ON: When light environment is under 5 Lux, the camera will switch to black and white mode.

However, when light environment is over 10 Lux, the camera will switch to color mode.

Please be informed that any D/N switch will result a delay of 4~5 seconds.

D/N OFF: Camera stays in color mode.

Note: when AGC setting is OFF, then D/N function will be inactive.

The default setting is OFF.

IRIS Level Adjustment

Brightness Level can be adjusted from the IRIS level VR.

- Turn counterclockwise to L to get darker picture.
- Turn clockwise to H to get brighter picture.

SIMPLE INSTRUCTIONS FOR THE DESICCANT PACK

Due to the camera lens blurred from the humidity inside the camera.

The desiccant pack absorbs the humidity; please refer to the easy instruction as follows:

1. Adjust all settings first and place the desiccant pack on the horizontal rod, then bend the horizontal rod and fix it.
2. Install the outer cover and tighten the screws.

Installation steps for the camera:

Step 1

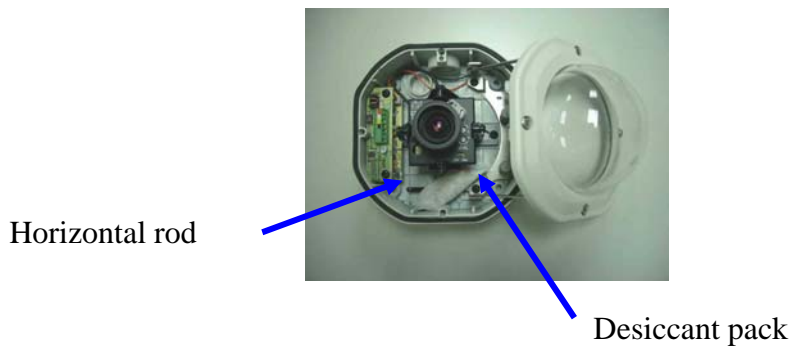

Step 2

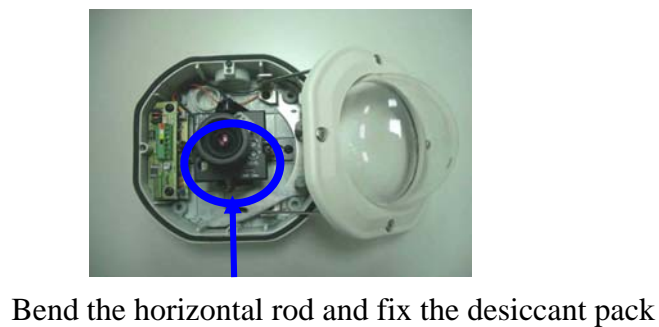

Step 3



SPECIFICATIONS

Pickup Device	1/3" SONY Super HAD CCD
Video Format	NTSC or PAL
Scanning System	NTSC: 525 TV lines, 60 fields/sec. PAL: 625 TV lines, 50 fields/sec.
Picture Elements	768 x 494(NTSC) ; 752 x 582(PAL)
Horizontal Resolution	520TVL
Sensitivity	0.4Lux/F=1.2
S/N Ratio	Over 48dB (AGC off)
Electronic Shutter	1/50(1/60)~1/100,000
Lens Type	Vari-focal lens, Auto Iris f=2.9~10mm f=3.7~12mm f=9~22mm
Auto Gain Control	ON/OFF Switch
Flickerless	ON/OFF Switch
H-Mirror	ON/OFF Switch
Day/Night Mode	ON/OFF Switch
Auto White Balance	Yes
Gamma Correction	0.45
Video Output	2 video outputs BNC 1.0Vp-p, 75ohm Additional testing video output 1.0Vp-p, 75ohm
Sync. Mode	Internal sync
Weatherproof	IP66
Vandal Resistant	Yes
Power Source	12VDC/24VAC
Power Consumption	24VAC: 4W max. 12VDC: 2W max.
Dimensions	130mm(W) x 98.8mm(H) x 130mm(D); 5.1"(W) x 3.87"(H) x 5.1"(D)
Weight	0.8kg ; 1.8lbs
Operating Temperature	-10°C~50°C ; 14°F~122°F (20%~80% Humidity)
Certifications	FCC/CE

CONTENT LIST

Standard Accessories

1. Camera Unit
2. Operation Instruction (this document)
3. Accessory Pack
4. Waterproof Connector
5. Power & Video Cable

Optional Accessory

1. Wall Mount Bracket (BA-EHD)

EverFocus Electronics Corp.

Headquarter Office

12F, No.79 Sec.1 Shin-Tai Wu Road,
Hsi-Chi, Taipei, Taiwan
Tel: +886-2-26982334
Fax: +886-2-26982380

Beijing office

Room 609, Technology Trade Building.
Shangdi Information Industry Base,
Haidian District, Beijing China
Tel: +86-10-62971096
Fax: +86-10-62971423

European Office

Albert-Einstein-Strasse 1,
D-46446 Emmerich, Germany
Tel: +49-2822-9394-0
Fax: +49-2822-939495

Japan Office

5F Kinshicho City Building , 2-13-4 Koto-bashi ,
Sumida-Ku , Tokyo , 130-0022 , Japan
Tel: +81-3-5625-8188
Fax: +81-3-5625-8189

USA California Office

1801 Highland Ave. Unit A
Duarte, CA 91010 ,U.S.A
Tel: +1-626-844-8888
Fax: +1-626-844-8838

USA New York Office

415 Oser Ave Unit S
Hauppauge, NY 11788
Sales: +1-631-436-5070
Fax: +1-631-436-5027

India Office

Suite 803, 8th Floor,
Housefin Bhavan,
C-21 Bandra Kurla Complex,
Bandra (East), Mumbai 400 051
Tel: +91 22 6128-8700

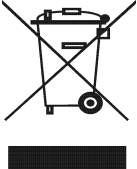
	<p>Your EverFocus product is designed and manufactured with high quality materials and components which can be recycled and reused. This symbol means that electrical and electronic equipment, at their end-of-life, should be disposed of separately from your household waste. Please, dispose of this equipment at your local community waste collection/recycling centre. In the European Union there are separate collection systems for used electrical and electronic product. Please, help us to conserve the environment we live in!</p>	<p>Ihr EverFocus Produkt wurde entwickelt und hergestellt mit qualitativ hochwertigen Materialien und Komponenten, die recycelt und wieder verwendet werden können. Dieses Symbol bedeutet, dass elektrische und elektronische Geräte am Ende ihrer Nutzungsdauer vom Hausmüll getrennt entsorgt werden sollen. Bitte entsorgen Sie dieses Gerät bei Ihrer örtlichen kommunalen Sammelstelle oder im Recycling Centre. Helfen Sie uns bitte, die Umwelt zu erhalten, in der wir leben!</p>
---	--	--



P/N: 4605XH0300002AR_Ver.B