

READ AND SAVE THESE INSTRUCTIONS

WARNING: A risk of fire and electrical shock exists in all electrical appliances and may cause personal injury or death. Please follow all safety instructions.

Choco Latte

Hot Beverage Machine

USE AND CARE GUIDE FOR
MODELS MECM1 AND MECM1CAN



IMPORTANT SAFEGUARDS

When using electrical appliances, basic safety precautions should always be followed to reduce the risk of fire, electric shock and injury to persons, including the following:

- Read all instructions before using appliance.
- Do not touch hot surfaces. Use handles or knobs.
- Do not immerse cord, plug or coffee-making unit in water or other liquid. See instructions for cleaning.
- This appliance is not for use by children.
- Close supervision is necessary when any appliance is used near children.
- Unplug from outlet when not in use. Unplug and allow to cool before attaching or removing parts and before cleaning the appliance.
- Do not let cord hang over edge of table or counter or touch hot surfaces.
- Do not place on or near a hot gas or electric burner or in a heated oven.
- Do not use appliance except as indicated in these instructions.
- Carafe must never be used on a range top. Use only the designated carafe for your coffeemaker.
- Do not use a cracked carafe or a carafe having a loose or weakened handle.
- Do not clean carafe with abrasive cleaners, steel wool pads or other abrasive material.
- Do not remove lid, filter basket or carafe during brewing cycle, scalding may occur. Allow filter basket to cool before removing it from coffeemaker.
- CAUTION: The milk discharge outlet gets hot when in use.
- To disconnect, switch off, then remove the plug from the wall outlet.
- Do not move entire unit when carafe contains hot liquid.
- Do not operate any damaged appliance. Do not operate with a damaged cord or plug, or after the appliance malfunctions or has been dropped or damaged in any manner. Return appliance to the nearest authorized service center for examination, repair, electrical or mechanical adjustment.
- Use accessory attachments only if recommended by manufacturer.
- Be certain lids are securely in place before operating appliance.
- Do not use outdoors or while standing in a damp area.
- WARNING: Do not remove bottom cover. No user serviceable parts inside. Repair must be done by authorized service personnel only.

SAVE THESE INSTRUCTIONS

THIS APPLIANCE IS FOR HOUSEHOLD USE ONLY

CAUTION: A short power supply cord is provided to reduce the risk of personal injury resulting from becoming entangled in or tripping over a longer cord. Extension cords are available from local hardware stores and may be used if care is exercised in their use. If an extension cord is required, special care and caution is necessary. Also the cord must be: (1) marked with an electrical rating of 125 V, and at least 13 A, 1625 W, and (2) the cord must be arranged so that it will not drop over the countertop or tabletop where it can be pulled on by children or tripped over accidentally.

POLARIZED PLUG: This appliance has a polarized plug, (one blade is wider than the other). As a safety feature to reduce the risk of electrical shock, this plug is intended to fit in a polarized outlet only one way. If the plug does not fit fully in the outlet, reverse the plug, If it still does not fit, contact a qualified electrician. Do not attempt to defeat this safety feature.

ELECTRIC POWER: If the electric circuit is overloaded with other appliances, your appliance may not operate properly. It should be operated on a separate electric circuit from other operating appliances.

FIGURE 1

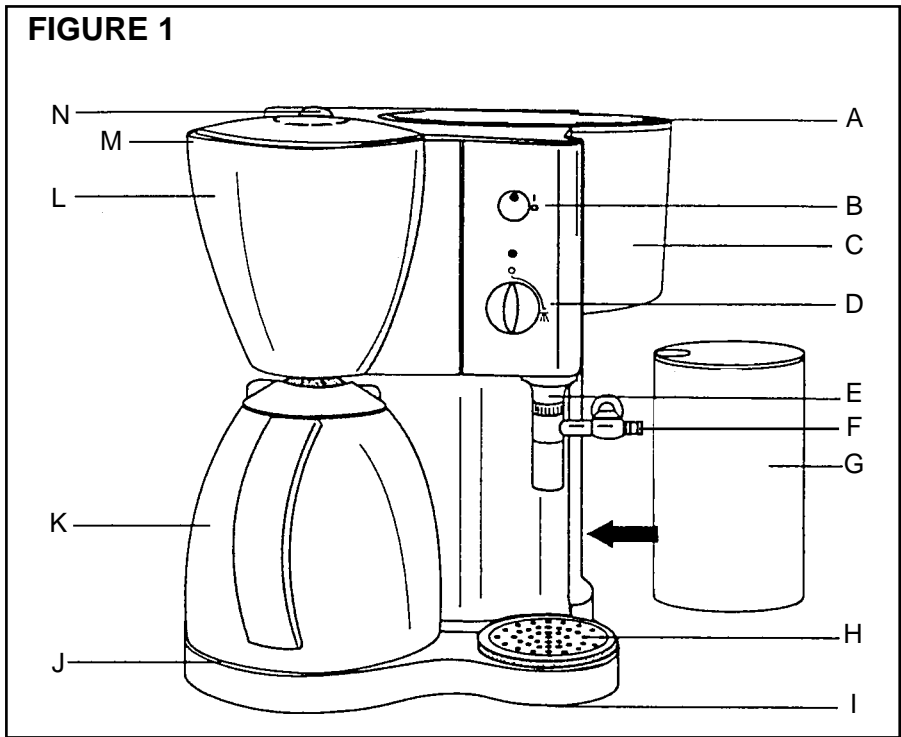
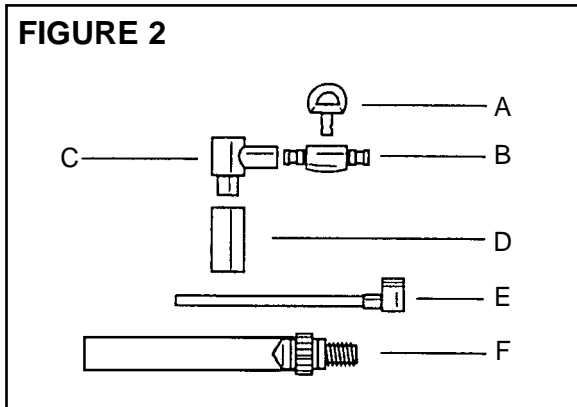

FIGURE 2



Features

Figure 1

- A Water tank lid
- B On/off switch with LED light
- C Water tank with cup markings
- D Steam selector ("OFF" position)
- E Steam nozzle
- F Feed pipe

- G Milk pitcher
- H Drip grid with drip tray
- I Base
- J Carafe base
- K Thermal Carafe
- L Swing-out filter
- M Removable filter liner
- N Button for opening the swing-out filter

Frothed milk spout

Figure 2

- A Froth regulator
- B Suction piece
- C Connector
- D Milk discharge outlet
- E Flexible hose
- F Descaling hose

Product may vary slightly from illustrations.

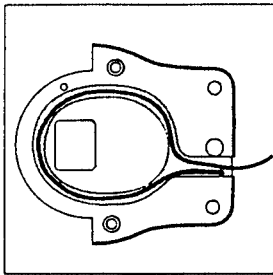

FIGURE 3

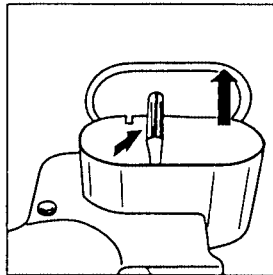

FIGURE 4

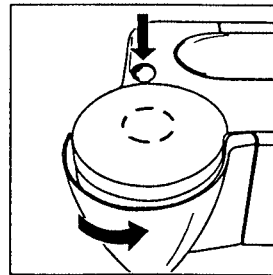

FIGURE 5

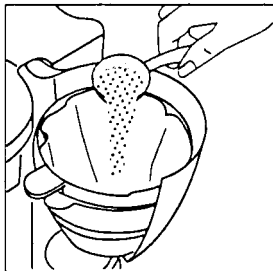

FIGURE 6

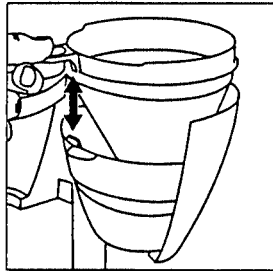

FIGURE 7

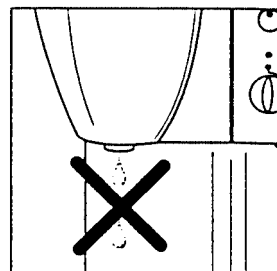

FIGURE 8

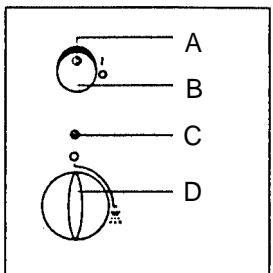

FIGURE 9

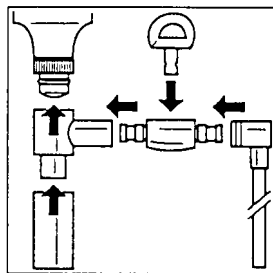

FIGURE 10

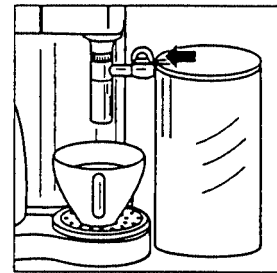

FIGURE 11

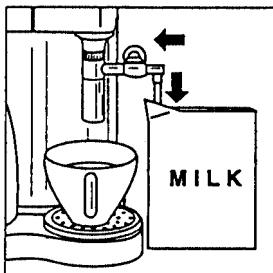

FIGURE 12

Congratulations on the purchase of your new Melitta® Choco Latte Hot Beverage machine. You have purchased an innovative and reliable appliance which we hope will give you years of enjoyment. As with every technical appliance, there are some fundamental aspects of this machine which should be observed. Please read the operating instructions carefully and keep them in a safe place. Above all, please pay attention to all safety instructions and warnings.

Cord Compartment (Figure 3)

Your machine has a cord storage compartment to hide excess cord and reduce countertop clutter.

Before Initial Use

Before you make coffee for the first time, you should perform the brewing procedure once or twice using the maximum quantity of water in order to clean your machine.

Fill the fresh water tank with cold water to the upper level marking. Without using ground coffee or filter paper, switch the appliance on and let the water run through it into the thermal carafe. Discard water after it has run through the machine.

Making Coffee

1. Fill with water (Figure 4)

Lift the lid above the water tank. Remove the water tank using the handle and fill it with cold tap water to the upper level marking.

Never use hot water. Never fill the water tank with milk, prepared coffee, tea, etc.

The cup markings are on the water tank (Figure 1/C). The markings refer to the quantity of fresh water. The actual yield amount of coffee will be less, because the ground coffee absorbs water.

Replace the water tank and close the lid.

Hint: To pre-warm the thermal carafe, rinse it out with hot water before making coffee. DO NOT fill the thermal carafe with cold water when it is still hot. All extreme temperature changes should be avoided.

2. Insert filter paper (Figure 5)

Press the button to open the swing-out filter (Figure 1/L). The filter automatically swings out to the right (Figure 5). Insert a Size 4 Melitta Cone paper filter into the filter holder. Fold the crimped edges over first.

3. **Fill with ground coffee (Figure 6).**

The amount of ground coffee to be used is a matter of taste. One measuring spoonful (approx. 6-7g/2 TBS) is recommended per cup for medium strength coffee. Swing back the filter until it clicks into position. Ensure that the filter liner is properly seated (Figure 7).

4. **Screw lid clockwise onto the thermal carafe and place on the carafe base.**

The lid must always be screwed onto the carafe because it activates the anti-drip valve (Figure 8). Although closed, coffee enters the carafe brew-through lid. It will remain hot and fresh for several hours.

5. **Switch on the appliance (Figure 9).**

Plug appliance into a 120V ~ 60 Hz outlet. Using the on/off switch (Figure 9/B), turn appliance on. The LED light (Figure 9/A) lights up.

6. **Remove the thermal carafe.**

When the carafe has been removed, the anti-drip valve (Figure 8) prevents surplus water from dripping on the carafe base. Therefore make sure that the filter liner (Figure 7) is properly seated.

To pour coffee, open the lid of the carafe by turning in a counter-clockwise direction (or until the raised round mark is over the spout). After pouring, close the lid by turning it in a clockwise direction until it is tight. This will help keep the rest of the coffee hot.

Unplug and allow to cool for 5 minutes between brewing cycles.

IMPORTANT: If coffeemaker is not allowed to cool before immediate repeated use, water placed in water carafe may become overheated. A spray of steam could be released from openings, creating a risk of burns.

Flavorings

Try adding 1 teaspoon of your favorite flavoring, e.g. vanilla, hazelnut, or caramel to coffee before adding frothed milk. Adjust to taste.

To froth or heat milk

You can make cappuccino, café latte and hot chocolate, or even just heat milk using the frothed milk spout (Figure 2/A, B, C, D).

Assemble the frothed milk spout as follows (Figure 10):

1. Insert the froth regulator (Figure 2/A) into the suction piece (Figure 2/B) and press it on firmly until froth regulator sits directly on top of suction piece.
2. Push the suction piece into the connector (Figure 2/C) and place the milk discharge outlet (Figure 2/D) onto the connector.
3. Firmly attach the complete frothed milk spout to the steam nozzle (Figure 1/E) until the red seal of the steam nozzle is no longer visible.
4. Leave the appliance switched on after the coffee has been made. (You will hear a gurgling sound when brewing is complete.)
5. Wait until the temperature indicator (Figure 9/C) lights up, indicating that the steam temperature has been reached.

Caution: During operation the temperature indicator (Figure 9/C) sometimes goes off. The required steam temperature is reached again within a short time by turning the Steam selector to the right (Figure 1D).

6. Fill the pitcher (Figure 1/G) with cold milk.
7. Replace the lid of the pitcher.
8. Securely connect the pitcher to the frothing nozzle (Figure 11).

You can also “vacuum” the milk directly out of a small milk container using the flexible hose (Figure 2/E).

Important: The small milk container must not be allowed to exceed the height of the steam nozzle. The flexible hose must be inserted down into the container.

Connect the flexible hose to the steam nozzle and insert the other end into the milk container (Figure 12).

Place an empty cup underneath the frothed milk spout (Figure 12).

9. Turn the Steam selector to the right (Figure 9/D). This “vacuums” the milk out of the milk pitcher or container. It is then mixed with steam in the frothed milk spout, and at the same time heated and frothed. The frothed milk flows through the milk discharge outlet into the cup. Return Steam selector to “OFF” position to stop milk flow.

Important: You can incorporate more or less air into the milk by using the froth regulator (Figure 2/A). To do this, turn the knob slowly to the left or the right until you achieve the desired result. More air in the milk will result in thicker froth.

10. After making the frothed milk, turn the steam selector to the off position.
11. You can froth as much milk as often as you like provided that there is enough excess water in the water tank. If necessary, simply add more water.

Caution: For frothing, do not fill the water tank above the top of the “well” at base of water tank, otherwise the water flows into the coffee brewing system.

Experiment to determine your preferences: first coffee, then adding frothed milk, or first frothed milk then adding coffee.

Making cocoa

You can make hot chocolate by adding chocolate syrup to taste (approximately 2-3 tablespoons per cup) to some milk in the milk pitcher and stirring it. Proceed as if frothing milk. The mixture will become completely heated by the hot steam in the frothing nozzle. The mixture can also be frothed if desired (see section “to froth or heat milk”).

Making Hot Tea

Tea leaves may be placed in the filter if you wish to make hot tea instead of coffee. To brew 40 ounces of hot tea, use 3½ tablespoons of fresh tea leaves or empty five 3¾ ounce bags of tea into paper filter.

To Heat Water

1. Fill the pitcher with water.
2. Connect the pitcher to the frothing nozzle.
3. Proceed as if frothing milk.
4. Switch off the appliance using the on/off switch.

Descaling to prolong the life of your machine

The service life of your hot beverage machine can be lengthened with regular descaling. We recommend descaling the appliance every three months. This will also result in better tasting coffee and other hot beverages.

If you use a permanent filter, remove it from the swing filter before descaling.

For descaling use a liquid, such as environmentally-friendly descaling agent available at retail outlets. Use it in accordance with the manufacturer’s instructions. Do not use a formic acid-based descaler.

Descaling your machine

Fill the water tank with water and then add the descaling agent in that order. Swing the swing-out filter back into the appliance. Place the carafe (with lid tightly screwed) onto the base (Figure 1/J). Please note that the lid serves to open the anti-drip valve, and is required to ensure that the water flows through correctly. Allow the descaling solution to take effect for about 15 minutes, then switch on the machine and allow the descaling solution to run through. Empty carafe. If necessary repeat the descaling procedure.

Remove the steam nozzle by turning it counter-clockwise. Screw on the descaling hose (Figure 2/F) and place a cup underneath. Switch on the steam selector several times for one minute. Switch off the appliance. If necessary repeat the descaling procedure. Rinse out the water tank with clear water to remove any possible traces of descaling solution.

Wait 5 minutes and then repeat the run-through process at least twice using clear water. Empty carafe after each run-through. Rinse the carafe, lid and filter liner thoroughly under running water. Repeatedly squeeze the anti-drip valve while rinsing.

Switch on the steam selector and allow clear water to flow through the steam system again to clean it. Remove the descaling hose and replace the steam nozzle.

Cleaning

Unplug from outlet. Clean all parts that come into contact with milk (frothed milk spout, pitcher, including lid and feed pipe, flexible hose, drip tray and drip grid) in warm, sudsy water immediately after each use. Dry the parts. Do not clean them in a dishwasher as this could damage the seals.

The filter liner can be removed for cleaning. Press button on top of machine (Figure 1N) and swing filter out to the right as far as it will go. The inner liner can then be removed (Figure 7). You should repeatedly press the anti-drip valve during cleaning, especially to remove all particles of coffee. Wipe the machine with a damp cloth, but **never immerse in water!** Wash out the carafe and lid with hot, sudsy water, using a brush if necessary. Rinse and dry it with a cloth. Do not clean it in a dishwasher.

What to do if . . .

- only steam but no frothed milk is produced:
 - Attach the pitcher or flexible hose correctly.
 - Put the frothed milk spout together correctly and firmly.

- Press the froth regulator firmly onto the suction piece and check the position of it (horizontal position for maximum amount of froth).
 - Too little or no milk in the pitcher.
 - The flexible hose in the milk carton does not reach far enough into the milk.
 - Steam nozzle or frothed milk spout requires cleaning.
- the volume of milk froth is too low or frothing takes too long:
 - Clean the frothed milk spout.
 - Clean the steam nozzle.
 - Descale the machine
 - Use skim or 1% milk.
- no steam is produced:
 - Refill the “well” in the water tank.
 - Insert the water tank correctly.

Spare parts / accessories

Thermal Carafe

If the glass in the thermal carafe breaks, you can purchase a new carafe without lid from the Consumer Relations Department by calling 1-800-947-3744.

Any servicing requiring disassembly other than the above cleaning must be performed by authorized service center.

IMPORTANT NOTICE

If any parts are missing or defective,

DO NOT return this product.

Please call our Customer Service Department for assistance.

800-233-9054 Monday - Friday 9:00 am - 5:00 pm CST

Thank You

LIMITED ONE YEAR WARRANTY

Warranty: This Melitta product is warranted by Salton, Inc. to be free from defects in materials or workmanship for a period of (1) year from the original purchase date. This product warranty covers only the original consumer purchaser of the product.

Warranty Coverage: This warranty is void if the product has been damaged by accident in shipment, unreasonable use, misuse, neglect, improper service, commercial use, repairs by unauthorized personnel, normal wear and tear, improper assembly, installation or maintenance abuse or other causes not arising out of defects in materials or workmanship. This warranty is effective only if the product is purchased and operated in the USA, and does not extend to any units which have been used in violation of written instructions furnished with the product or to units which have been altered or modified or to damage to products or parts thereof which have had the serial number removed, altered, defaced or rendered illegible.

Implied Warranties: ANY IMPLIED WARRANTIES WHICH THE PURCHASER MAY HAVE ARE LIMITED IN DURATION TO ONE (1) YEAR FROM THE DATE OF PURCHASE. Some states do not allow limitations on how long an implied warranty lasts, so the above limitation may not apply to you.

Warranty Performance: During the above one-year warranty period, a product with a defect will be either repaired or replaced with a reconditioned comparable model (at our option) when the product is returned to the Repair Center, or the purchase price refunded. The repaired or replacement product will be in warranty for the balance of the one-year warranty period and an additional one-month period. No charge will be made for such repair or replacement.

Service and Repair: Should the appliance malfunction, you should first call toll-free 1 (800) 233-9054 between the hours of 9:00 am and 5:00 pm Central Standard Time and ask for CONSUMER SERVICE stating that you are a consumer with a problem. Please refer to model number MECM1 when you call.

In-Warranty Service (USA): For an appliance covered under the warranty period, no charge is made for service or postage. Call for return authorization (1 800 233-9054).

Out-of Warranty Service: A flat rate charge by model is made for out-of-warranty service. Include \$ 15.00 (U.S.) for return shipping and handling. We will notify you by mail of the amount of the charge for service and require you to pay in advance for the repair or replacement.

For Products Purchased in the USA, but Used in Canada: You may return the product insured, packaged with sufficient protection, and postage and insurance prepaid to the USA address listed below. Please note that all customs duty / brokerage fees, if any, must be paid by you and we will require you to pay the cost of customs duty / brokerage fees to us in advance of our performing any service.

Risk During Shipment: We cannot assume responsibility for loss or damage during incoming shipment. For your protection, carefully package the product for shipment and insure it with the carrier. Be sure to enclose the following items with your appliance: any accessories related to your problem, your full return address and daytime phone number, a note describing the problem you experienced, a copy of your sales receipt or other proof of purchase to determine warranty status. C.O.D. shipments cannot be accepted.

To return the appliance, ship to:

Attn: Repair Center
Salton, Inc.
708 South Missouri Street
Macon, MO 63552
Email: Salton@Saltonusa.com

To contact us, please write to,
call, or email:

Salton, Inc.
P.O. Box 6916
Columbia, MO 65205-6916
1(800) 233-9054

Limitation of Remedies: No representative or person is authorized to assume for Salton, Inc. any other liability in connection with the sale of our products. There shall be no claims for defects or failure of performance or product failure under any theory of tort, contract or commercial law including, but not limited to negligence, gross negligence, strict liability, breach of warranty and breach of contract. Repair, replacement or refund shall be the sole remedy of the purchaser under this warranty, and **in no event shall Salton be liable for any incidental or consequential damages, losses or expenses.** Some states do not allow the exclusion or limitation of incidental or consequential damages, so the above limitation or exclusion may not apply to you.

Legal Rights: This warranty gives you specific legal rights, and you may also have other rights which vary from state to state.

For more information on Salton products:
Visit our website: www.salton-maxim.com