



Specifications: IW500b

System Type	5.25" Coax, in wall, sealed (32 Watt transformer for 25/70.7/100 Volt or 8 Ohm direct)
Impedance (nominal) ¹	8 ohm
Sensitivity dB @ 2.83V/1M	87.5 dB
Sensitivity dB @ 1W/1M ²	87.5 dB
Frequency Response (-3 dB) ³	140 Hz - 22 kHz
Frequency Response (-10 dB) ³	69 Hz - 22 kHz
Max. Program Power ⁴	150w
Max. Continuous Power RMS ⁵	75w
Max. Power SPL @ 1 M ⁶	106.5 dB
Coverage Angle (-6 dB @ 2 kHz)	90° horizontal / 100° vertical
Coverage Angle (-6 dB @ 10 kHz)	70° horizontal / 85° vertical
Coverage Angle (Avg. from 2 to 10 kHz)	115° horizontal / 115° vertical
Directivity Factor (Q)	4.9 (Avg. 100 Hz - 10 kHz) / 8.3 (2 kHz)
Directivity Index (DI) dB	6.0dB (Avg. 100 Hz - 10kHz) / 9.2dB (2 kHz)
Tap Selector	6-Position rotary switch with 8 ohm direct
Transducer - Low Frequency Driver	1 x 133 mm (5.25 in) Polypropylene cone, butyl rubber surround
Transducer - High Frequency Driver	25mm (1in) Convex aluminum tweeter with waveguide
Low Frequency Voice Coil	25.4 mm / 1.00 in
Crossover Frequency	3.0 kHz
Network Type: Low Pass	12 dB per octave, 2nd order
Network Type: High Pass	12 dB per octave, 2nd order
Motor-board	Cast aluminum
Grille	Iridite-plated steel with powder-coat finish
Inputs	Wire leads
Colors	White (only), Paintable
Height	11.84 in / 300.7 mm
Width	8.64 in / 219.5 mm
Depth	3.90 in / 99.1 mm
Weight	8.9 lb / 4.0 kg
Shipping Weight	11.0 lb / 5.0 kg
Included Accessories	1 UL listed 1/2" conduit connector, 2 wire nuts, paint mask, hole template
Optional Accessories	Preconstruction bracket (AC-IW-PCB)
Packaging	1 per box
Regulatory - UL	Backcan listed to UL1480
Regulatory - CE	Approved

¹ Impedance listed per IEC 60268-5 with a minimum less than 80% the nominal impedance

² 1w1m sensitivity determined using nominal impedance

³ Frequency response measured in half or full space as dictated by speaker mounting configuration

⁴ Max program power is 3 dB above max continuous power

⁵ Continuous power rating, EIA-426-B test

⁶ Max output based on max continuous power

⁷ Max useable SPL based on testing by NWA Labs

Transformers

70.7 V Output		100 V Output		25 V Output	
33 w	102.5 dB	33 w	102.5 dB	5 w	94.5 dB
17 w	100.0 dB	17 w	100.0 dB	2.5 w	91.5 dB
9 w	97.0 dB	9 w	97.0 dB	1.3 w	88.5 dB
6 w	95.5 dB	6 w	95.5 dB	0.63 w	85.5 dB
3 w	92.5 dB				

Key Features

- BroadBeam® waveguide technology delivers a consistent dispersion pattern up to 10 kHz for maximum coverage area per speaker (EASE™ documented).
- One 133 mm (5.25 in) polypropylene woofer and one 25 mm (1 in) convex aluminum tweeter with FerroFluid cooling mounted to an M5 Motorboard.
- 106.5 dB Max. SPL offers high output capabilities and reduced amplification costs.
- Rapid installation blind-mount system for quick and secure installation.
- Easy-access 6-position tap switch for 25, 70.7 & 100 Volt applications with voice coil/8 Ohm direct simplifies ordering & inventory tracking.
- Integrated UL-listed steel enclosure with conduit connections.
- Included accessories: Mounting hardware, paint mask, hole template and conduit connector.
- Optional accessory: Pre-construction bracket (AC-IW5-PCB).
- High-quality white paint finish. Custom paint colors optional.

Description

The IW500b is a 5.25" coax in-wall loudspeaker that delivers effective low-end response (69 Hz, -10 dB) and optimal off-axis performance (up to 10 kHz, EASE™ documented). SoundTube's proprietary BroadBeam® waveguide tweeter system delivers consistent high-performance audio across the operating bandwidth. The IW500b speaker design incorporates a low-profile grille and 6-position tap switch with an 8 Ohm bypass. Mounting hardware is included and features a fast and secure optimally engineered constant-tension mounting system and an integrated backcan for maximum efficiency and applications where UL approval is required. A pre-construction bracket is offered as an optional accessory.

Applications

Designed for in-wall applications, the IW500b is ideal for music and messaging in boardroom, church, corporate A/V and education applications. For additional bass response down to 41 Hz (-10 dB), the CM1001d subwoofer may be used.



Patented SoundTube Technologies

SoundTube Entertainment and the MSE Audio Group constantly develop new technologies which enhance audio product performance. SoundTube Entertainment innovations are protected by multiple U.S. & international patents, which explicitly cover SoundTube dome, enclosure and dispersion technologies. The MSE Audio Group actively defends its patents in order to protect SoundTube resellers and end-users.

Technical Data and Specification Tools

Technical Data

SoundTube Entertainment strives to provide complete and effective technical information and data to dealers, engineers and designers. All data are available from SoundTube Entertainment or at www.soundtube.com and includes EASE™ Data – 3-D polar plots and SoundTubeSPEC™ – Proprietary SoundTube speaker placement software.

Independent Data Acquisition and Verification

All data for SoundTube speakers are independently collected from and verified by NWAALabs (www.nwaalabs.com).

com) using their proprietary MACH testing system. All data is collected and analysed according to ASTM, ISO and AES standards using EASERA, TEF and MLSSA. Full balloon data including both phase and magnitude is compiled into a variety of formats including EASE 4.x, GLL and CLF.

Architectural Specifications

The loudspeaker shall consist of a 133 mm (5.25 in) low-frequency transducer and a 25 mm (1 in) high-frequency transducer with a frequency-dividing network installed in a sealed enclosure. The low-frequency transducer shall have a polypropylene cone with a butyl rubber surround. The high-frequency transducer shall be constructed of aluminum with a proprietary BroadBeam® waveguide.

The low-frequency voice coil diameter shall be 25.4 mm (1 in).

Performance specifications of a typical production unit shall be as follows: Useable frequency response shall extend from 69 Hz – 22 kHz (-10 dB, half space, no external equalization). Measured sensitivity (2.83 Volt, 1 meter) shall be at least 87.5 dB. The speaker shall have a nominal impedance of 8 Ohms and shall be available for 25/70.7/100 Volt modes with voice

coil/8 Ohm direct. The frequency-dividing network shall have a cross-over frequency of 3 kHz with slopes of 12 dB per octave (second order) for both low and high-pass filters. Rated power capacity shall be at least 75 Watts continuous power (RMS) and conform to EIA-426-B testing. Maximum continuous output at 1 meter shall be 106.5 dB.

Installation for the IW500b shall be by 4-screw, constant-tension optimally engineered mounting assembly. The external wiring input connector shall be by hard wired leads for 8 Ohm or distributed systems.

The grille shall be constructed of powder-coated steel for lasting performance and attach via pressure fit directly to the ABS bezel. The backcan shall be constructed of drawn steel.

The system shall be the SoundTube IW500b with mounting hardware for both low & high impedance applications.

SoundTube Entertainment

6430 North Business Park Loop
Park City, Utah 84098
Phone 435.647.9555
Fax 435.647.9666
Toll Free 800.647.TUBE
www.soundtube.com

Graphs and Plots

Frequency Response

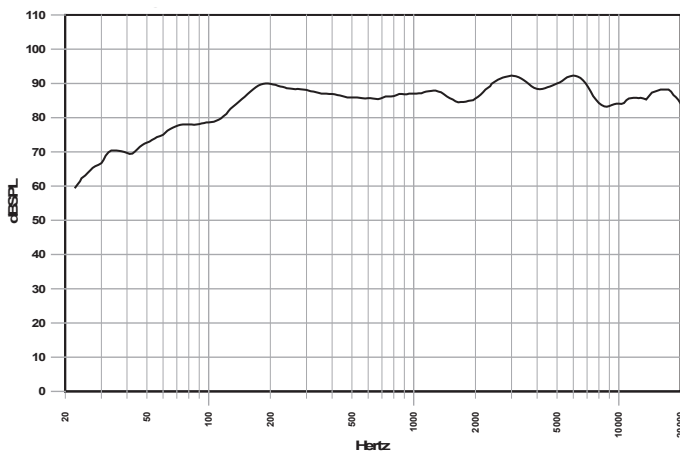

Phase/Impedance Response

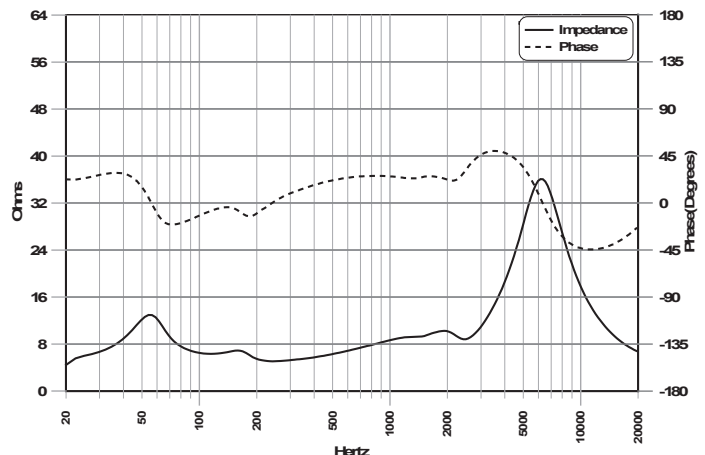



Horizontal Beamwidth

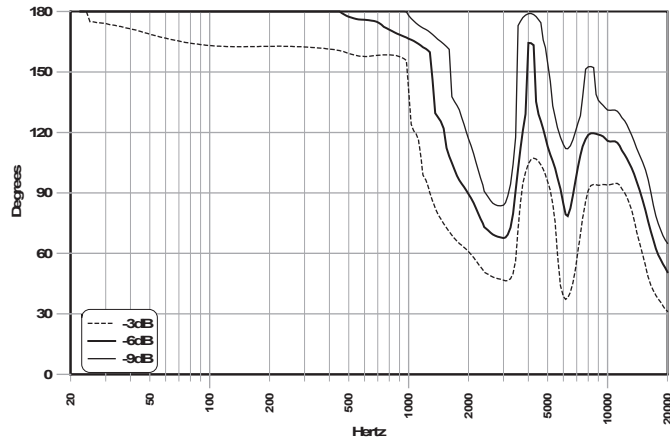

Vertical Beamwidth

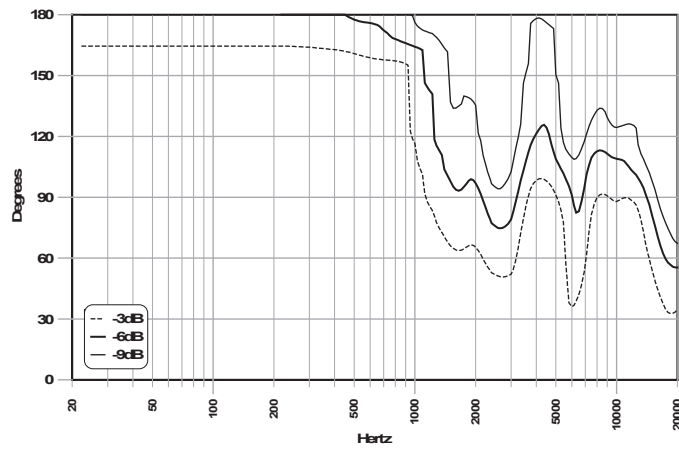

Directivity Index (DI)

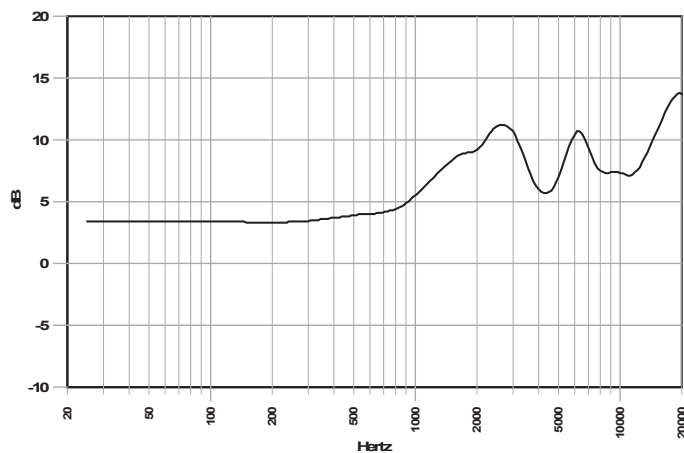

IW500b

In-Wall Speaker

Technical Information for System Engineers



SOUNDTUBE
ENTERTAINMENT

Polar Plots

— Horizontal
- - - Vertical

125 Hz

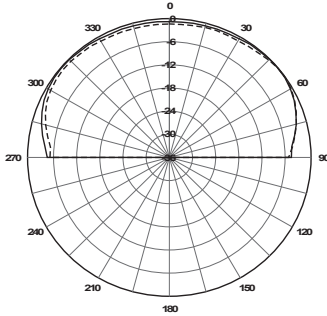

250 Hz

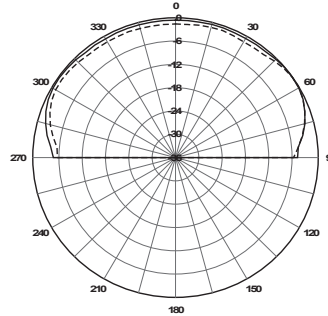

500 Hz

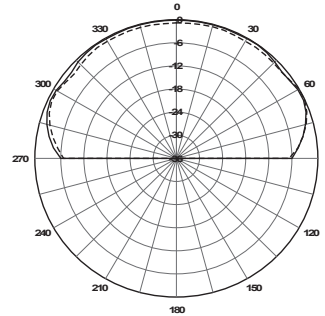

1,000 Hz

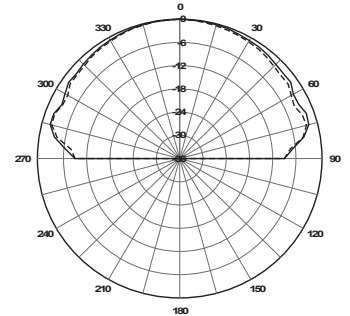

2,000 Hz

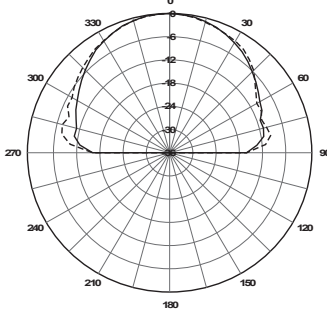

4,000 Hz

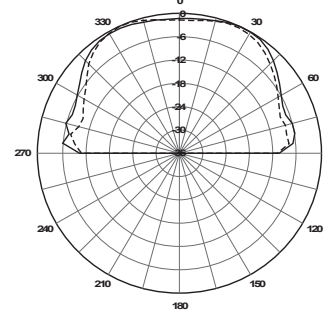

8,000 Hz

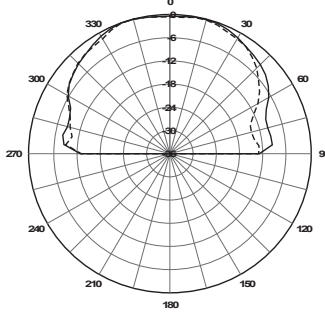

10,000 Hz

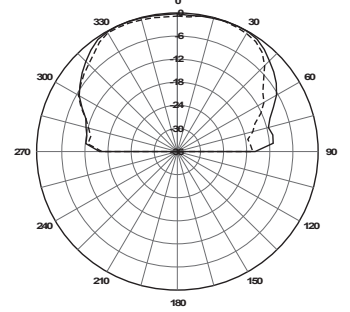

Technical data, EASE™ plots, SoundTubeSPEC™ software & product downloads available at www.soundtube.com

Mechanical Drawings

Side

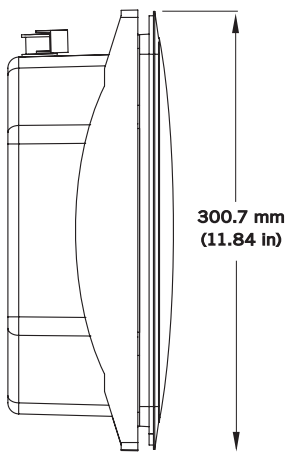

Top

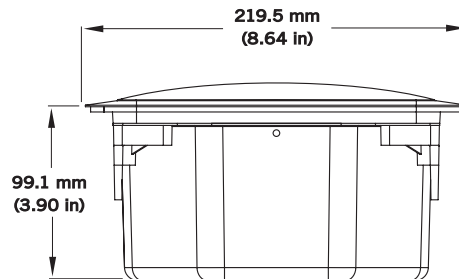

Front

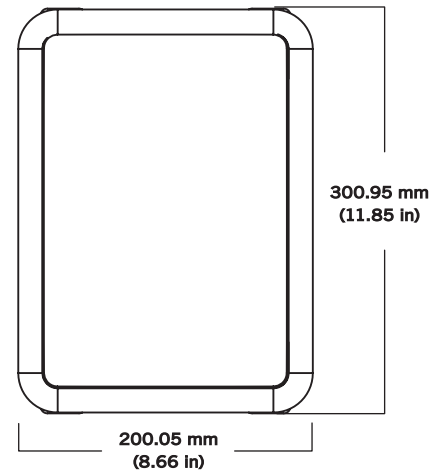

Included Accessories

N/A

Optional Accessories - Pre-Construction Bracket

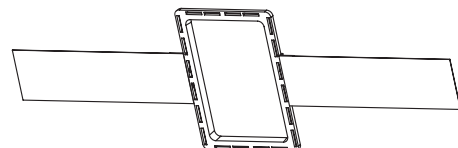

SoundTube Entertainment manufactures a complete line of speakers for:
Open-Ceiling • In-Ceiling • Surface-Mount • Outdoor • Sound-Focusing

All SoundTube products are designed and engineered in the USA.