

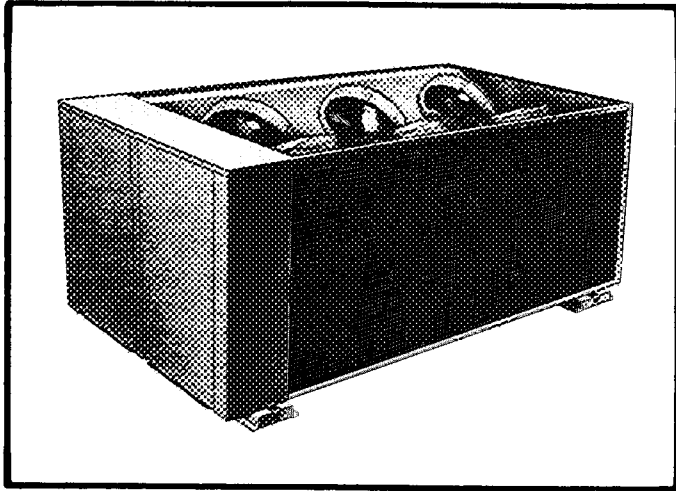

Advance Product Data

Nominal 60-Ton Capacity

Packaged Air-Cooled Flotronic™ Liquid Chiller **30GB060**



Features

- Unit nominal capacity serves virtually any large commercial or institutional air conditioning need or industrial process cooling requirement.
- High-tech solid-state electronic control circuitry tested to U.S. Government Space Agency standards.
- Microprocessor control maintains total control over chiller functions, permitting intelligent control of the refrigerant cycle.
- Diagnostic module with digital display included to permit rapid troubleshooting just by pressing a button.
- Electronic expansion valves (EXV) operate down to 15 psig (103 kPa) pressure differential. (Ordinary thermostatic expansion valve typically requires 100 psig [690 kPa] differential.) This reduces compressor motor power requirements and improves the unit EER.
- Flotronic™ chiller provides up to 28% efficiency improvement over standard 30GB chillers on an annual basis.
- Additional operating cost savings with precise multiple-step compressor capacity control.
- Multiple compressors and dual refrigerant circuits help to protect against the possibility of loss of total capacity.
- Semi-hermetic 06E compressors are serviceable in the field.

- Designed for outdoor installation to minimize required mechanical room space.
- Air-cooled condenser design saves condenser water and eliminates cooling tower.
- Domestic units will operate to 115 F (46 C).
- Protection against freeze-up — low water temperature cutoff and electric heaters protect cooler.
- Available as standard with aluminum fins and copper tubes for normal applications, or with all-copper coils.

Field-installed accessories

- Demand limit control module (required for remote ON/OFF control)
- Leaving chilled water temperature reset accessory board
- Sensor kit assembly for outdoor or space temperature reset of chilled water temperature
- Ground current refrigeration circuit protection
- Discharge and suction pressure gage panel
- Oil pressure switch package includes oil pressure switches (2) for unit
- Capacity control: accessory electric suction cutoff unloader
- Motormaster® head pressure control (requires unit modification for low-ambient operation)

Factory-installed option (FIOP)

Thermal expansion valves — For those situations where energy savings of the EXV are secondary and equipment first costs are most important. With this option, the electronic expansion valve and controls related to the EXV function, head pressure control and its related part-load energy savings, are deleted from unit and are replaced by thermal expansion valves and liquid line solenoid valves. Minimum operating ambient for FIOP TXV-equipped units with standard head pressure control is 32 F. Contact your Carrier representative for details on operation at temperatures below 32 F. The FIOP model continues to have microprocessor features and diagnostic capability. Standard accessories are useable.

Table of contents

	Page		Page
Features	1	Dimensions	10
Field-Installed Accessories	1	Mounting Weights	10
Factory-Installed Option (FIOP)	1	Electrical Data	11
Model Number Nomenclature	2	Controls	11,12
Physical Data	2	Control Sequence	13
Application Data	2-6	Typical Installation	14
Selection Procedure	6	Guide Specifications	15,16
Performance Data	7-9		

Model number nomenclature

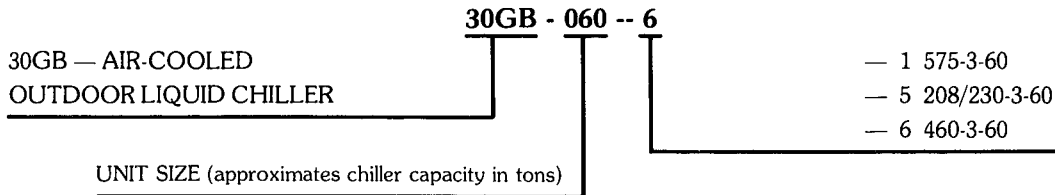

Physical data

MODEL 30GB	060
APPROX OPER WT — lb	4900
REFRIG CHG — lb	
Circuit 1	65
Circuit 2	85
COMPRESSORS, Type...Rpm	Reciprocating, Semi-Hermetic 1750
(No.) Circuit 1*	(1) 6275
(No.) Circuit 2	(1) A299
Capacity Control Steps	4
Circuit 1 (%)	43
Circuit 2 (%)	57
Minimum Step Capacity (%)	29
CONDENSER FANS — Type	Propeller, Direct Drive
Fan Speed — Rpm	1080
No. Blades...Diameter-in.	
Circuit 1/Circuit 2	4...26/3 ..30
No. Fans...Total kW	6. 1 92
Total Airflow — Cfm	46500
CONDENSER COILS — Type	Plate Fins (Aluminum†)
Tubes (Copper), OD-in.	½
Fins/in. Circuit 1/Circuit 2	14 2/15.0
No. Rows Circuit 1/Circuit 2	¾
Face Area (sq ft) Circuit 1	57.5
Circuit 2	57.5
Max. Working Pressure Refrig psig	450
COOLER — No. ...Type	One...Direct Expansion, Shell & Tube
Model 10HA400---	824
No. Refrigerant Circuits	2
Net Water Volume — Gal. (includes nozzles)	17.7
Max. Working Press. — psig	Refrigerant Side-235, Water Side-150
WATER CONNECTIONS	MPT
Inlet and Outlet — in.	3
Drain — in. FPT	¾

*6 prefix indicates one electric unloader.

†A" prefix indicates no unloader.

†Copper fins also available

Application data

Leveling unit

Unit must be level when installed to ensure proper oil return to the compressors.

While most outdoor locations are suitable for 30GB units, the roof is a common site that presents a problem if roof has been pitched to aid in water removal. To assure proper oil return, be sure that unit is level, particularly in its major lengthwise dimension, as compressor oil return piping runs in that direction.

It should be determined prior to installation if any special treatment is required to assure a level installation.

Cooler temperature

- Maximum leaving chilled water temperature (LCWT) for Model 30GB is 70 F (21 C). Unit can start and pull down with up to 95 F (35 C) entering water temperature due to MOP (maximum operating pressure) feature of the expansion valve. For sustained operation, it is recommended that entering water temperature not exceed 85 F (29.4 C).*
- Minimum LCWT for standard Model 30GB is 40 F (4.5 C). It is permissible to use a standard microprocessor-controlled Flotronic chiller with leaving water temperatures in the range of 34 F (1°C) to 39.9 F (4.4 C) only if a protective brine solution (20% antifreeze solution, or greater) is used and microprocessor dip switch is properly set. (See Controls and Troubleshooting book for further information.) Special order medium temperature brine units must be ordered for operation with leaving water temperatures in the range of 34 F (1°C) to 15 F (-9 C). For ratings below 40 F (4.5 C) LCWT, contact your local Carrier representative.*

Application data (cont)

MINIMUM COOLER WATER FLOW RATES AND MINIMUM LOOP VOLUME

UNIT 30GB	MINIMUM FLOW (1)	PRESSURE DROP	MINIMUM VOLUME (2)
	Gpm	ft of water	Gallons
060	67	3.8	180

NOTES.

1. Minimum flow based on 1.5 fps velocity in cooler without special cooler baffling
2. Minimum Loop Volumes:
Gallons = V x ARI Cap (tons)

APPLICATION	V
Normal Air Conditioning	3
Process Type Cooling	6
Low Ambient Unit Operation	6

Leaving water temperature reset

Accessory board* may be installed in 30GB chillers to provide reset of LCWT in constant water flow systems. Reset reduces compressor power usage at part load when design LCWT is not necessary. Humidity control should be considered since higher coil temperatures resulting from reset will reduce latent heat capacity. Three reset options are offered:

From return water temperature* — Increases LCWT temperature set point as return (or entering) water temperature decreases (indicating load decrease). Option may be used in any application where return water provides accurate load indication. Limitation of return water reset is: LCWT may only be reset to value of design return water temperature. Return reset is the simplest of 3 reset accessories available, as return water sensor is already installed.

From outdoor temperature* — Increases LCWT as outdoor ambient temperature decreases (indicating load decrease). This reset should be applied only where outdoor ambient is an accurate indication of load. An accessory thermistor is required.

From space temperature* — Increases LCWT as space temperature decreases (indicating load decrease). This reset should be applied only where space temperature is an accurate indication of load.

For details on applying a reset option, refer to 30GB Controls and Troubleshooting Instructions.

*Obtain ordering part numbers from current price pages.

Cooler flow range

Ratings and performance data in this publication are for a cooling range of 10°F or 6°C. Flotronic™ chillers with microprocessor control may be operated at a different temperature range provided flow limits are not exceeded. For minimum flow rates, see Table. High flow rate is limited by pressure drop that can be tolerated. If another range is used, apply LCWT correction as given in selection example.

Minimum cooler flow (maximum cooler temperature range) for standard units is shown in Table. When gpm (L/s) required is lower (or range higher), follow recommendations below:

- Multiple smaller chillers may be applied in series, each providing a portion of the design temperature range.
- Cooler water may be recirculated to raise flow rate. However, mixed temperature entering cooler must be maintained a minimum of at least 5°F (2.8°C) above the leaving chilled water temperature.

- Special cooler baffling is required to allow minimum flow rate to be reduced 12%.

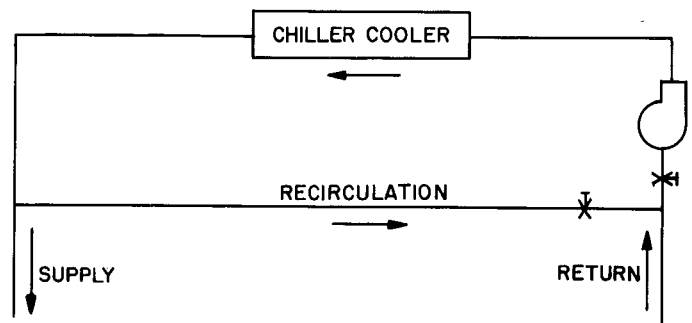

Maximum cooler flow (>5 gpm/ton or <5 F range [>0.09 L/s • kW or <2.7 C range]) results in practical maximum pressure drop through cooler.

- Return water may bypass the cooler to keep pressure drop through cooler within acceptable limits. This permits a higher ΔT with lower water flow through cooler and mixing after the cooler.
- Special cooler baffling is available by special order, to permit a cooler flow rate increase of 10%.

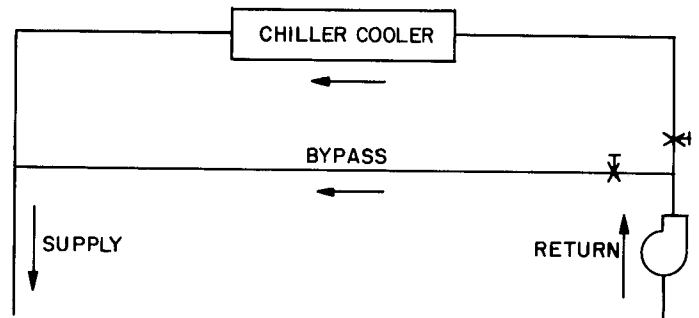

Variable cooler flow rates may be applied to a standard 30GB chiller. Unit will, however, attempt to maintain a constant leaving chilled water temperature. In such cases, minimum flow must be in excess of minimum flow given in Table and flow rate must change in steps of less than 10% per minute. Apply 6 gallons per ton (6.5 liters per kW) water loop volume minimum if flow rate changes more rapidly.

Water loop volume — In circulation must equal or exceed 3 gallons (11.4 liters) per nominal ton of cooling (3.25 liters per kW) for temperature stability and accuracy in normal air conditioning applications. (For example, a 30GB060 would require 180 gallons in circulation in system loop — see Table.) For process jobs where accuracy is vital or for operation at ambient below 32 F (0°C) with low unit loading conditions, there should be from 6 to 10 gallons

Application data (cont)

per ton (6.5 to 10.8 liters per kW). To achieve this volume, it is often necessary to install a tank in the loop. Tank should be baffled to insure that there is no stratification and that water (or brine) entering tank is adequately mixed with liquid in the tank.

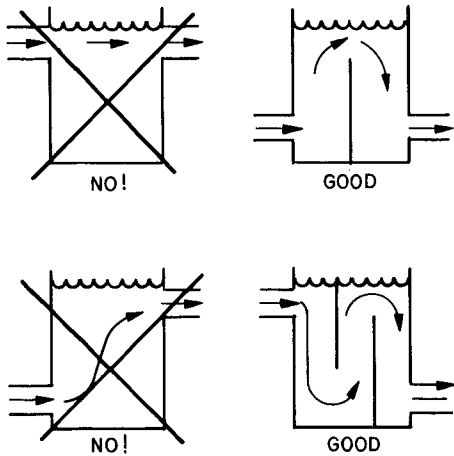

Cooler fouling factor used to calculate tabulated ratings was 0.0005 ft² · hr · °F/Btu (0.000088 m² · K/W). As fouling factor is increased, both unit capacity and compressor power decrease. Standard ratings should be corrected using following multipliers:

FOULING FACTOR		CAPACITY MULTIPLIER	COMPRESSOR POWER MULTIPLIER
ENGLISH (ft ² · hr · °F/Btu)	SI (m ² · K/W)		
0.0005	0.000088	1.00	1.00
0.001	0.000176	0.97	0.98
0.002	0.000352	0.91	0.91

Cooler protection in form of ethylene glycol (or other suitable brine) is recommended when operating in areas which experience temperatures below 32 F (0°C) to protect cooler should there be a loss of cooler heater power. Even though unit cooler is protected with insulation and an electric heater that protects the cooler down to 10 F (-12 C), it does not protect water piping external to unit. Use only antifreeze solutions approved for heat exchanger duty. Use of automotive antifreezes is not recommended because of the fouling that can occur once their relatively short-lived inhibitor breaks down.

Draining cooler and outdoor piping is recommended if system is not to be used during freezing weather conditions. See section below for low-ambient operation.

Condenser

Altitude correction factors must be applied to standard ratings at altitudes above 2000 ft (610m) using following multipliers:

ALTITUDE		CAPACITY MULTIPLIER	COMPRESSOR POWER MULTIPLIER
ENGLISH (ft)	SI (m)		
0	0	1.00	1.00
2000	610	0.99	1.01
4000	1220	0.98	1.02
6000	1830	0.97	1.03
8000	2440	0.96	1.04
10000	3050	0.95	1.05

Condenser airflow restrictions will affect the unit capacity, condenser head pressure and compressor power input. Correction factors to be applied for external static restrictions up to 0.2 in. wg (50 Pa) are shown below.

EXTERNAL STATIC RESISTANCE		CAPACITY MULTIPLIER	COMPRESSOR POWER MULTIPLIER
ENGLISH (in. wg)	SI (Pa)		
0.0	0.0	1.00	1.00
0.1	25	0.986	1.01
0.2	50	0.968	1.03

High-ambient temperature — Standard 30GB chillers can operate to 115 F (46 C) ambient temperature.

Low-ambient operation

Flotronic™ 30GB chillers with electronic expansion valves (EXV) will start and operate at ambients down to 0°F (-18 C) with following field provisions:

Wind baffles must be added for operation below 32 F (0°C).

⚠ WARNING

Operation at low ambient is not recommended if minimum load on chiller is below minimum step of unloading.

Protection against freeze-up — It is recommended that field-installed chilled water piping be protected at lower ambient temperatures by wrapping with field-supplied heating cable and covering with 2-in. (50-mm) thick closed-cell insulation.

Antifreeze solution must be added to water loop to protect loop down to 15 F (8 C) below minimum operating ambient temperature.

For operation of EXV-equipped chillers below 0°F (-18 C) and for operation of TXV-equipped (factory-installed option) chillers below 32 F (0°C), down to -20 F (-29 C), the Carrier Motormaster® condenser head pressure control and its associated components must be added. Consult your local Carrier representative for complete details.

Provide sufficient volume in the chilled water loop — At least 6 gallons per ton of refrigerant (6.5 liters per kilowatt) is recommended minimum, provided there is a moderate system load.

Capacity Correction (Antifreeze)

Ethylene glycol (or other suitable brine) should be used in installations where subfreezing temperatures are expected. Unit performance data must be corrected for the addition of ethylene glycol as shown in following example. Correction factors may be derived from following curves.

Example: Where a 5 F outdoor temperature is anticipated, determine concentration of ethylene glycol to protect system to -10 F ambient temperature at zero flow.

Enter the solution crystallization point curve at -10 F, read 40% concentration of ethylene glycol is required to prevent crystals from forming in solution.

Consider the 30GB060 unit from the Selection Procedure (Water) example (refer to correction curves at 40% solution).

Application data (cont)

Correct unit capacity — On glycol performance capacity correction curve, read 0.95.

$$\begin{aligned} \text{Corrected capacity} &= 0.95 \times \text{determined capacity} \\ &= 0.95 \times 61.3 \\ &= 58.2 \text{ tons} \end{aligned}$$

Correct chilled water flow — On the gpm correction factor curve, read 1.15.

$$\begin{aligned} \text{Chilled water flow (at corrected capacity)} &= \frac{24 \times \text{corrected capacity}}{\text{temperature rise}} = \text{U.S. gpm} \\ &= \frac{24 \times 58.2 \text{ tons}}{14 \text{ F}} = 99.8 \text{ U.S. gpm} \end{aligned}$$

$$\begin{aligned} \text{Chilled water flow (40\% solution)} &= 1.15 \times 99.8 \\ &= 114.7 \text{ U.S. gpm} \end{aligned}$$

Correct cooler pressure drop — On cooler pressure drop correction curve, read 1.33.

On cooler pressure drop curve, for 114.7 gpm, read PD = 10 ft water gage. The pressure drop for 40% solution = $1.33 \times 10.0 = 13.3$ ft water.

Correct compressor power input (kW) — On power correction curve, read 0.97 correction factor at 40% EG concentration.

Power input from Selection Procedure example = 71.1 kW.

$$\text{Corrected power input} = 0.97 \times 71.1 = 68.9 \text{ kW.}$$

ETHYLENE GLYCOL PERFORMANCE CORRECTION FACTORS AND SOLUTION CRYSTALLIZATION POINTS

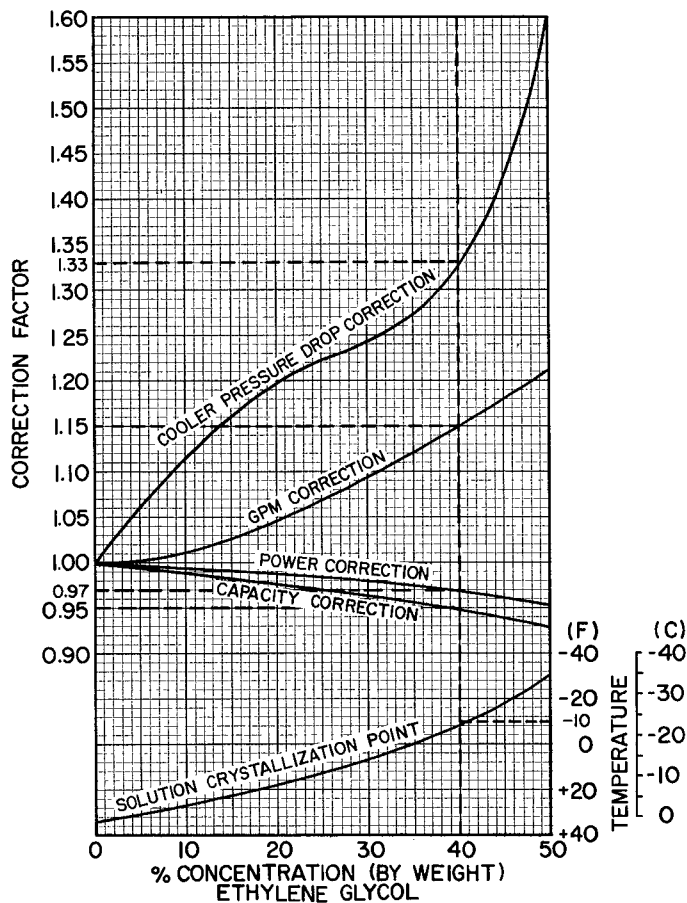

Oversizing chillers

Oversizing chillers by more than 15% at design conditions must be avoided as the system operating efficiency would be affected adversely (resulting in greater/excessive electrical demand). When future expansion of equipment is anticipated, it is strongly recommended that a single chiller be installed to meet present load requirements and a second chiller added to meet the additional load demand.

It is also recommended that the installation of 2 smaller chillers be considered where operation at minimum load is critical. The operation of a smaller chiller loaded to a greater percent of minimum is preferred to operating a single chiller at or near its minimum recommended value.

Multiple chillers

Where chiller capacities greater than 200 tons (703 kW) are required, or where stand-by capability is desired, chillers may be installed in *parallel*. Units should be of equal size to ensure balanced water flows. Where a large temperature drop ($>25 \text{ F}$ [13.9 C]) is desired, chillers may be installed in *series*. Water temperature sensors need not be moved for multiple chiller operation. A 10-ft (3-m) separation is required between units for airflow, and a 6-ft (1.8-m) distance is required from units to obstructions. See figure. See Physical Data for service clearances.

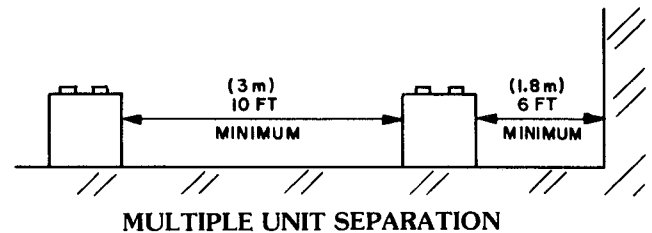

Electrical/utility interests

Energy management — See 30GB Controls and Troubleshooting manual and accessory installation instructions for details.

Demand limiting (also called load shedding) — When utilities demand for electricity exceeds a certain level, loads are shed to keep electricity demand below a prescribed maximum level. Typically, this happens on hot days when air conditioning is most needed.

Load shedding must be done intelligently. Demand may be limited on Model 30GB by resetting water temperature, or by using a demand limit accessory that unloads the chiller to a given predetermined percent of the load. Both features require signal from an intelligent central control. Do not cycle demand limiter for less than 10 minutes on and 5 minutes off.

Duty cycling cycles electrical loads at regular intervals regardless of need. This reduces electrical operating costs of a building by "fooling" demand indicating devices. Duty cycling of compressors or fans is *not* recommended since motor winding and bearing life suffer from constant cycling.

Application data (cont)

Time clock shutdown (or other controlled shutdown not associated with leaving chilled water temperature) requires use of accessory demand limit control module. Second step of the demand limit control (0-50% of capacity) is set for 0 (zero) capacity. This allows unit to go through a normal pumpout cycle at shutdown.

Part-wind start

Not generally required on 30GB chillers due to use of multiple compressors allowing smaller electrical load increments, but is available if required. Maximum instantaneous current flow (see ICF in Electrical Data) should be used in determining need.

Vibration isolation

Compressors are spring isolated. External vibration isolation is not generally required.

Selection procedure

I Determine unit size and operating conditions required to provide specified capacity at given conditions:

Capacity required 60 tons
Leaving chilled water temperature 45 F
Chilled water temperature rise 14 F
Condenser entering air temperature (CEAT) .. 95 F
Loop volume 230 gallons

Ratings are based on 10 F rise and are suitable for rise from 5 F to 15 F without adjustment. In this case, however, greater accuracy is desired.

II Correct LCWT for 14 F cooler water temperature rise.

Enter correction curve at 14 F and read a correction of 0.3 F. Corrected LCWT is, therefore, 45 + 0.3 = 45.3 F.

III Determine capacity, unit size and power input.

Enter rating table at given CEAT and LCWT — respectively 95 F and 45 F.

Read down capacity column until the capacity nearest to but higher than specified required capacity is reached. In this case, 60.9 tons is delivered by a 30GB060. Interpolate between 45 F and 46 F to find

Hot gas bypass usage (units with TXV only)

Hot gas bypass usage, while frequently specified, is not normally recommended because it results in equipment being applied below its normal application range. Before applying hot gas bypass, it is recommended that use of 2 machines be considered, including one that can be run at the system minimum load without addition of hot gas bypass. In those instances where there is no alternative, it is recommended that the appropriate hot gas bypass package can be used with the factory option TXV unit.

Medium temperature brine application — Application of 30GB outdoor chillers for brine duty within the 39.9 F to 34 F (4.4 C to 1°C) range is possible with proper field change of control configuration. Application in the range 34 F to 15 F (1°C to -9.4 C) requires 30GB unit with factory modification.

determined capacity and power input at corrected LCWT (45.3 F). Values are:

Capacity 61.3 tons
Power input 71.1 kW

IV Calculate corrected cooler water flow.

$$\begin{aligned} \text{Water flow} &= \frac{24 \times \text{corr capacity in tons}}{\text{temperature rise F}} = \text{U.S. gpm} \\ &= \frac{24 \times 61.3}{14} = 105.1 \text{ U.S. gpm} \end{aligned}$$

V Calculate the cooler pressure drop.

Enter cooler pressure drop curve at the corrected flow rate (105.1 U.S. gpm) and read, for the 30GB060, a pressure drop of 9 ft of water.

VI Check loop volume and cooler water flow rate.

Minimum loop volume, from application data, is 180 gallons for 30GB060. Therefore, given volume of 230 gallons is satisfactory. Minimum water flow rate, from application data, is 67 gpm for 30GB060. Flow rate of 105.1 gpm is well above minimum required.

Performance data

STANDARD RATINGS* — REFRIGERANT 22

UNIT 30GB	CAPACITY		COMPRESSOR POWER INPUT (kW)	FAN POWER (kW)	COOLER WATER PRESSURE DROP (ft water)	ENERGY EFFICIENCY RATIO (EER)
	(tons)	(Btuh)				
060	59.7	716,400	68.4	7.81	13.7	9.4

*Per ARI Standard 590-81, Section 7.2

NOTE: 95 F condenser entering air temperature; 54 F entering/44 F leaving cooler water; 0.0005 ft² • hr • °F/Btu cooler fouling allowance.

$$EER = \frac{\text{Capacity (Btuh)}}{\text{Input Power (W)}}$$

30GB060 PART-LOAD EFFICIENCY (EXV UNITS ONLY)

BUILDING COOLING LOAD PROFILE

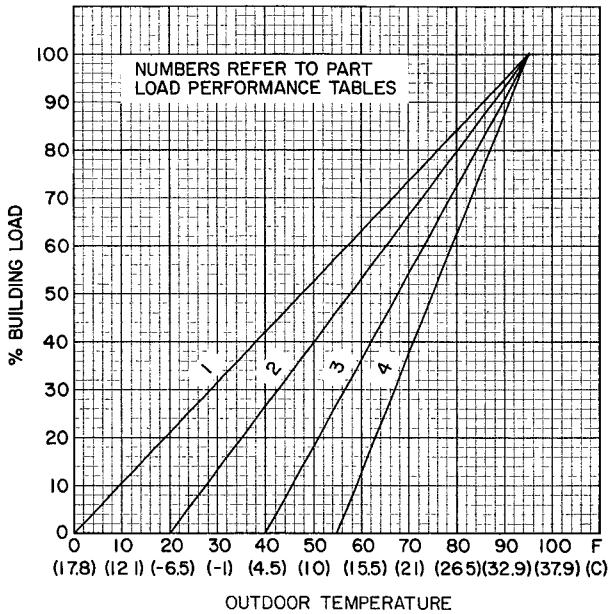

MINIMUM CAPACITY STEP (%)

MODEL 30GB	STANDARD UNIT*	STANDARD UNIT WITH ACCESSORY UNLOADER†
060	29	29

*Includes factory-furnished unloader where applicable.

†With field-installed accessory unloader

NOTE: See Table of Capacity Control Steps.

1 ZERO LOAD AT 0° F (-17.8 C) ODT			
% SYSTEM FULL LOAD	OUTSIDE AMBIENT TEMP		UNIT EER
	F	C	
100	95.0	35.0	9.4
90	85.5	29.8	10.6
80	76.0	24.3	11.8
70	66.5	19.0	13.0
60	57.0	13.9	14.2
50	47.5	8.5	16.9
40	38.0	3.1	21.6
30	28.5	-2.0	26.2

3 ZERO LOAD AT 40 F (4.4 C) ODT			
% SYSTEM FULL LOAD	OUTSIDE AMBIENT TEMP		UNIT EER
	F	C	
100	95.0	35.0	9.4
90	89.5	31.9	10.3
80	84.0	28.9	11.1
70	78.5	25.8	12.0
60	73.0	22.8	12.8
50	67.5	19.7	14.2
40	62.0	16.7	17.3
30	56.5	13.6	20.4

2 ZERO LOAD AT 20 F (-6.5 C) ODT			
% SYSTEM FULL LOAD	OUTSIDE AMBIENT TEMP		UNIT EER
	F	C	
100	95.0	35.0	9.4
90	87.5	30.9	10.0
80	80.0	26.5	10.5
70	72.5	22.3	11.1
60	65.0	18.2	11.6
50	57.5	14.0	12.6
40	50.0	10.0	14.7
30	42.5	5.9	16.9

4 ZERO LOAD AT 55 F (12.5 C) ODT			
% SYSTEM FULL LOAD	OUTSIDE AMBIENT TEMP		UNIT EER
	F	C	
100	95.0	35.0	9.4
90	91.0	32.8	9.8
80	87.0	30.6	10.2
70	83.0	28.3	10.6
60	79.0	26.1	10.9
50	75.0	23.9	11.2
40	71.0	21.7	12.7
30	67.0	19.3	14.4

ODT — Outdoor Temperature

NOTES:

- Above efficiency ratings obtained at 54/44 F (12.2/6.7 C) cooler water; full load at 95 F (35 C).
- The longer the time operating at low temperatures, the greater the difference in operating costs favoring a Flotronic™ unit over a standard TXV unit.

3 Contact your local Carrier representative for a computer analysis of operating costs.

EER = Energy Efficiency Ratio

$$= \frac{\text{Capacity (Btuh)}}{\text{Input Power (W)}}$$

Performance data (cont)

TOTAL COOLER PRESSURE DROP (Water Side)

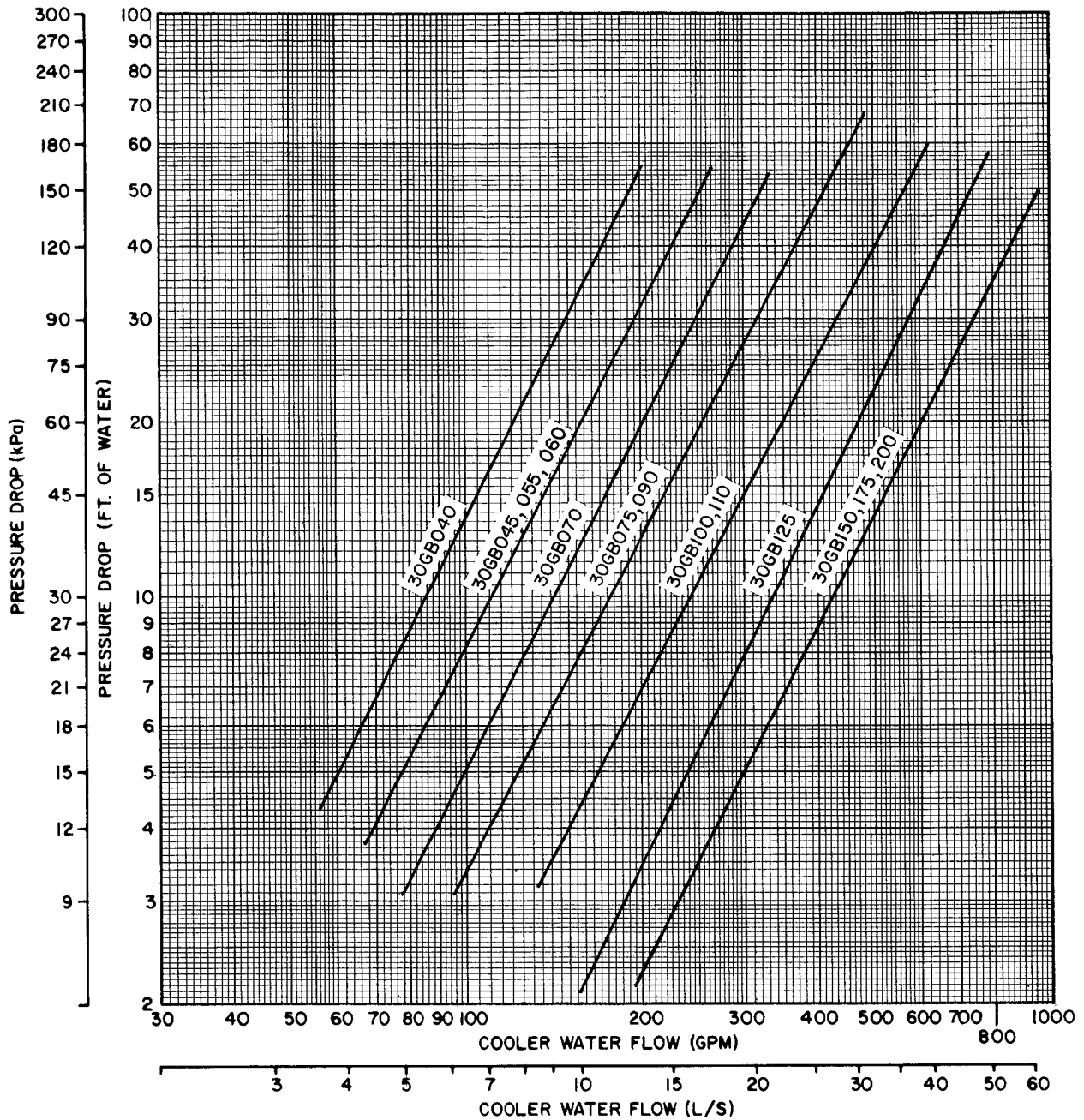

CAPACITY CONTROL STEPS

UNIT 30GB060	CONTROL STEPS	% DISPLACEMENT (Approximate)	LOADING SEQUENCE A (Note 1)				LOADING SEQUENCE B (Note 1)			
			Operating				Operating			
			No. of Compr	No. of Cyl	Compressor No.		No. of Compr	No. of Cyl	Compressor No.	
				Circuit 1	Circuit 2			Circuit 1	Circuit 2	
Standard (One Unloader)	1	29	1	4	1*	—	—	—	—	
	2	43	1	6	1	—	—	—	—	
	3	72	2	10	1*	2	—	—	—	
	4	100.0	2	12	1	2	—	—	—	
Accessory Unloader Added to Compressor No. 2	1	38	1	4	1*	—	1	4	—	2*
	2	66	2	8	1*	2*	2	8	1*	2*
	3	85	2	10	1*	2	2	10	1	2*
	4	100	2	12	1	2	2	12	1	2

*Compressor unloaded.

NOTES:

1. The microprocessor has a random number generator that selects loading sequence A or B, which in turn determines the compressor circuit that is energized first. This evens out operating hours on each circuit over an extended period of time

2. If unit operation is anticipated with system load below minimum unloaded capacity of chiller:

- Consider using 2 smaller units in place of larger unit.
- Increase water loop volume to ensure adequate run time (see Application Data).

Performance data (cont)

COOLING CAPACITIES — 30GB060

LCWT	CONDENSER ENTERING AIR TEMPERATURE (F)														
	85					90					95				
	Cap.	SDT	kW	Cooler		Cap.	SDT	kW	Cooler		Cap.	SDT	kW	Cooler	
				Flow Rate	PD				Flow Rate	PD				Flow Rate	PD
40	58.5	113.2	63.7	139.9	12.4	56.7	117.7	65.4	135.6	11.7	55.0	122.1	67.0	131.5	11.0
42	60.9	114.3	65.1	145.7	13.4	59.1	118.7	66.9	141.4	12.6	57.3	123.2	68.6	137.1	11.9
44	63.4	115.3	66.5	151.7	14.4	61.5	119.8	68.4	147.2	13.6	59.7	124.2	70.1	142.9	12.9
45	64.6	115.9	67.2	154.7	15.0	62.7	120.3	69.1	150.2	14.2	60.9	124.8	70.9	145.8	13.4
46	65.9	116.5	67.9	157.8	15.6	64.0	120.9	69.9	153.2	14.7	62.1	125.3	71.7	148.7	13.9
48	68.4	117.6	69.4	164.0	16.8	66.5	122.0	71.4	159.4	15.9	64.6	126.5	73.3	154.8	15.0
50	71.1	118.8	70.8	170.4	18.0	69.1	123.2	72.9	165.7	17.1	67.1	127.6	74.9	161.0	16.2
55	77.9	121.8	74.6	187.0	21.5	75.8	126.2	76.9	182.0	20.5	73.8	130.6	79.1	177.0	19.4
60	85.2	125.1	78.5	204.6	25.6	82.9	129.4	81.0	199.3	24.3	80.7	133.8	83.4	193.9	23.1

LCWT	CONDENSER ENTERING AIR TEMPERATURE (F)									
	105					115				
	Cap.	SDT	kW	Cooler		Cap.	SDT	kW	Cooler	
				Flow Rate	PD				Flow Rate	PD
40	51.6	131.1	70.0	123.3	9.7	48.1	140.0	72.6	114.9	8.5
42	53.8	132.1	71.7	128.7	10.5	50.2	141.0	74.4	120.1	9.2
44	56.1	133.2	73.4	134.2	11.4	52.4	142.0	76.3	125.4	10.0
45	57.2	133.7	74.3	137.0	11.9	53.5	142.5	77.3	128.1	10.5
46	58.4	134.2	75.1	139.9	12.4	54.6	143.1	78.2	130.8	10.9
48	60.8	135.3	76.9	145.7	13.4	56.9	144.1	80.1	136.3	11.8
50	63.2	136.4	78.7	151.6	14.4	59.2	145.2	82.1	142.0	12.7
55	69.5	139.3	83.2	166.8	17.3	—	—	—	—	—
60	76.2	142.4	87.8	183.1	20.7	—	—	—	—	—

LEGEND

- Cap. — Cooling Capacity Tons of Refrigeration
- Flow Rate — U S Gpm
- kW — Compressor Power Input
- LCWT — Leaving Chilled Water Temperature (F)
- PD — Pressure Drop (Ft of Water)
- SDT — Compressor Saturated Discharge Temperature (F)

NOTES:

- 1 Ratings apply to units with electronic or thermal expansion valves.
2. All ratings are based on.
 - a. A cooler chilled water temperature rise of 10°F. When greater accuracy is desired, correct design LCWT, before entering rating tables, by reference to the LCWT correction curve.
 - b. A fouling factor of 0.0005 in the cooler.
 - c. Refrigerant 22.
- 3 When a corrected LCWT is used, cooler pressure drop must also be corrected for new LCWT:
 - a. Enter rating table for corrected LCWT. By interpolation, determine corrected capacity (tons) and power input (kW) to compressor at its rated voltage.
 - b. Calculate corrected flow rate through the cooler.

$$= \frac{24 \times \text{capacity in tons}}{\text{temperature rise F}} = \text{U S gpm}$$
 - c. Enter cooler pressure drop curve at corrected flow rate and read pressure drop
4. When chilled water temperature rise is less than 5°F, high flow rate will normally be accompanied by an excessive pressure drop. In such cases, contact your Carrier representative for special selection of a cooler with wider baffle spacing.

LCWT CORRECTION

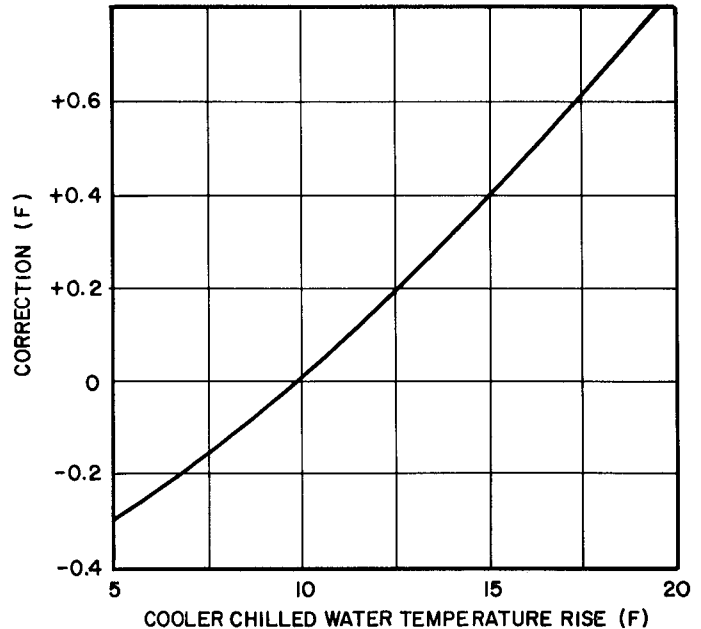

Above 10F, ADD correction to design LCWT, below 10 F, SUBTRACT

Dimensions

DIMENSIONS — ft-in.
(mm)

DIM.	UNIT 30GB060
A	13-7 $\frac{1}{8}$ (4162)
B	11-3 (3429)
C	12-5 $\frac{1}{2}$ (3797)
D	10-0 $\frac{1}{2}$ (3061)
E	5-8 $\frac{3}{32}$ (1730)
F	5-3 $\frac{3}{4}$ (1619)
G	4-6 $\frac{5}{8}$ (1387)
H	7-6 (2286)
J	5-0 (1524)

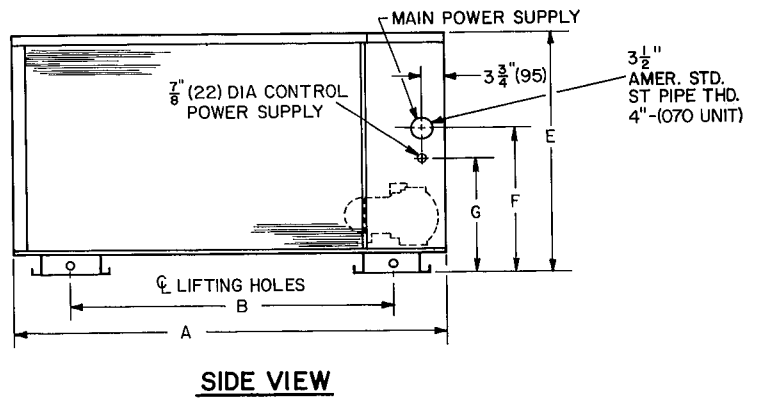
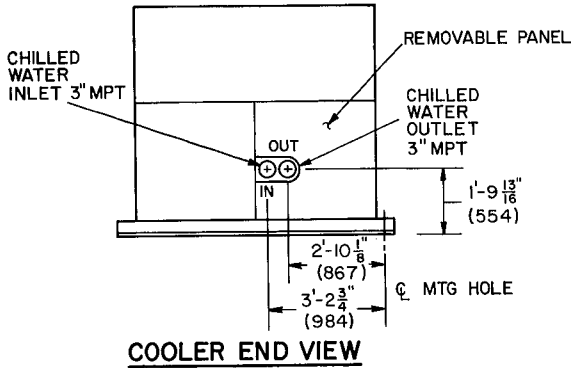
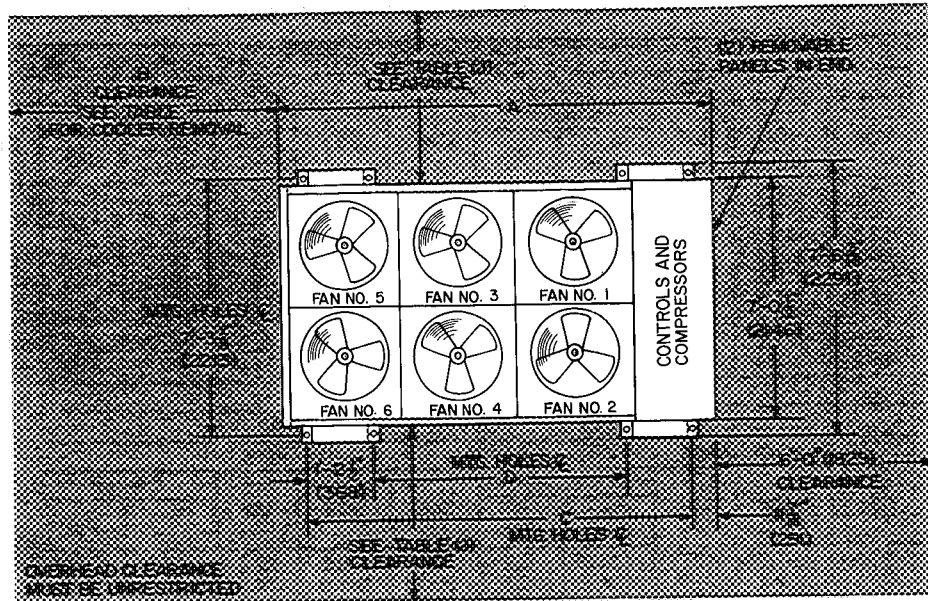

Space for service and airflow.

Mounting weights (approximate) lb

WEIGHT DISTRIBUTION

SUPPORT POINTS	UNIT 30GB060
1	1578
2	1528
3	922
4	872

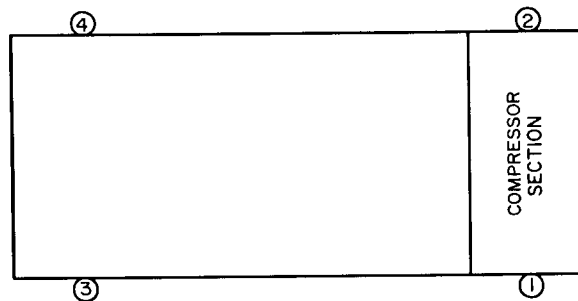

Electrical data — 60 Hz

30GB	UNIT						COMPRESSORS†						FAN MOTORS‡			
	Volts		MCA	MOPA (Fuse)	ICF	RLA (ea)		LRA (ea)		Total MTA		Total Fans (Ph)	FLA (ea) Fan No.		MTA (FCB)	
	Nameplate	Supplied*				Compressor No.		CB No.		Fan No.						
		Min	Max	1	2	1	2	1	2	1,2	3,4,5,6					
060	208-230	187	254	342	500	846	119	158.5	506	690	166	222	6 (1)	4.6	7.7	35
	460	414	508	155	225	415	53	73	253	345	73	90	6 (1)	2.3	3.3	18
	575	518	632	128	125	335	45	59	176	276	63	82	6 (1)	1.8	2.6	14

NOTE: As shipped, all units are XL (across the line) start.

*Units are suitable for use on electrical systems where voltage supplied to the unit terminals is not below or above the listed minimum and maximum limits.

†30GB060 has 2 compressors.

‡30GB060 has one FCB for all fans.

GENERAL ELECTRICAL NOTES:

- Unit listings are:
UL — Underwriters Laboratories: 30GB060
- Electrical data based on unit conforming to ARI Standard 590, Section 8.1. *Maximum Loading Conditions* (115 F ambient at -10% voltage)
- All units have single-location power connection to simplify field-power wiring. Main power must be supplied from a field-supplied fused disconnect. Unit must be properly grounded.
- Control circuit power must be supplied from a separate source through a field-supplied fused disconnect. (See Note 9.)
- Crankcase and cooler heaters are wired into the control circuit so they are always operable as long as the control circuit power supply disconnect is on, even if any safety device is open or the unit ON/OFF switch is off.

- Heaters are wired ahead of the control circuit fuse; thus, they are protected by the overcurrent protective device in the control circuit power supply.
- On all voltages, 30GB060 has one terminal block, with 3 conductors from the fused disconnect.
- Maximum incoming wire size for each terminal block is 500 MCM.
- Amperage required for control circuit is as follows:

UNIT 30GB	POWER SUPPLY	CONTROL CIRCUIT	
		Power	Amps
060	208/230-3-60	115-1-60	15
	460-3-60	115-1-60	15
	575-3-60	115-1-60	15

- Power draw of control circuits includes both crankcase heaters and cooler heaters. Each compressor has a crankcase heater that draws 200 watts of power.
Cooler heaters: 060 - 360 watts — band heaters (360 watts total).

Controls

Microprocessor — Microprocessor controls overall unit operation. Its central executive routine controls a number of processes simultaneously. These include internal timers, reading inputs, A to D conversions, fan control, display control, diagnostic control, output relay control, demand limit, capacity control, head pressure control and temperature reset. Some processes are updated almost continuously, others every 2 to 3 seconds, and some every 30 seconds.

The microprocessor routine is started by switching control circuit ON-OFF circuit breaker switch to ON. (This switch is also used to reset microprocessor should any safety trip and also functions as circuit breaker for electronic processor and relay boards.)

When the switch is closed, a 2-minute initialization routine is begun. During this time, inputs are checked, EXV and internal constants are initialized and a 20 appears on display. If display button is pushed during this period, control goes into a 42-step Quick Test routine, normally used for a readiness check during start-up, or for service.

Microprocessor controls capacity of chiller by cycling compressors and unloaders on and off at a rate to satisfy actual dynamic load conditions. Control will maintain leaving water temperature set with dial on display board through intelligent cycling of compressors. Accuracy will depend on loop volume, loop flow rate, load, outside air temperature, number of stages, and particular stage being cycled off. No adjustment for cooling range or cooler flow rate is required, because the control automatically compensates for cooling range by measuring both return water temperature and leaving water temperature. This is referred to as *leaving water temperature control with return water temperature compensation*.

The basic logic for determining when to add or remove a stage is a time band integration of deviation from set point plus rate of change of leaving water temperature. When leaving water temperature is close to set point and slowly moving closer, logic prevents addition of another stage. If leaving water temperature is less than 35 F (1.7 C) for water, or 6°F (21°C) below the set point for brine units, the unit is shut off until the water temperature goes 6°F (3.3°C) above the set point, to protect against freezing.

If 1°F/minute (0.6°C/minute) pulldown control has been selected (factory setting), no additional steps of capacity will be added as long as difference between leaving water temperature and set point is greater than 4°F (2.2°C) and rate of change in leaving water temperature is less than 1°F/minute (0.6°C/minute).

If it has been less than 90 seconds since the last capacity change, compressors will continue to run unless a safety trips. This prevents rapid cycling and also helps return oil during short on periods.

Where available (requires accessory unloaders on some units), 2 sequences are used to obtain circuit lead-lag operation, which evens out compressor operating hours. First, as unit turns on, microprocessor functioning as a random number generator, determines which circuit will start first. Also, when decreasing from maximum stage, control will again randomly select which circuit to run longest.

The control also performs other special functions when turning on or off. When a circuit is to be turned off, EXV is closed first and compressor is run for an additional 10 seconds to pump out refrigerant that was in the cooler. Again, at start-up, if compressor hasn't run in the last 15 minutes, EXV is held closed for 10 seconds while

Controls (cont)

compressor runs to pump out any refrigerant that has migrated to the cooler. The oil pressure switch is bypassed for one minute during start-up and for 45 seconds during normal operation.

Thermistors — Eight thermistors are used for temperature sensing inputs to microprocessor. (A ninth [T10] may be used as a remote temperature sensor for optional LCWT reset.)

- T1 Cooler leaving chilled water temperature
- T2 Cooler entering water (return temperature)
- T3 Saturated condensing temperature — Circuit #1
- T4 Saturated condensing temperature — Circuit #2
- T5 Cooler saturation temperature — Circuit #1
- T6 Cooler saturation temperature — Circuit #2
- T7 Return gas temperature entering compressor cylinder — Circuit #1
- T8 Return gas temperature entering compressor cylinder — Circuit #2
- T10 Remote temperature sensor (accessory)

The microprocessor uses these temperatures to control capacity, fan cycling and electronic expansion valve (EXV) operation.

Electronic expansion valve (EXV) — To control flow of refrigerant for different operating conditions, EXV piston moves up and down over slot orifices through which refrigerant flows to modulate size of opening. Piston is moved by a stepper motor through 760 discrete steps. The piston is repositioned by microprocessor every 3 seconds.

The EXV is used to control superheat in compressor. Two thermistors in each circuit (T5 and T7/T6 and T8) are used to determine superheat. One thermistor (T5/T6) is located in cooler and other (T7/T8) in compressor after motor in the gas passage entering the cylinders. The EXV is controlled to maintain superheat entering pistons at approximately 15 F (8.3 C) to 20 F (11.1 C), which results in slightly superheated refrigerant leaving cooler.

Both on shutdown and start-up, unless compressor has run in last 15 minutes, compressor runs for 10 seconds, while EXV is closed and removes refrigerant from cooler. These pumpout cycles minimize amount of excess refrigerant that can go to compressor on start-up and cause oil dilution which would result in eventual bearing wear.

The microprocessor software is programmed so that EXV functions as an MOP. (maximum operating pressure) valve, limiting the suction temperatures to 55 F (12.8 C). This makes it possible to start unit at high water temperatures, up to 95 F (35 C), without overloading compressor. Another feature that is factory set (which may be eliminated in the field by repositioning a dip switch on the microprocessor) limits rate of pulldown to 1°F (0.6°C) per minute thereby reducing the kW demand on start-up.

Accessory controls — Demand can be further limited by keeping a selected number of compressors from turning on by utilizing demand limit control accessory. This interfaces with microprocessor to control unit so that chiller's kW demand does not exceed its setting. It is activated from an external switch.

Microprocessor is programmed to accept various accessory temperature reset options, based on return water temperature, outdoor temperature, or space temperature, that reset the LCWT. An accessory thermistor (T10, above) is required if outdoor temperature or space temperature reset is elected.

Compressor protection and control system (CPCS) (30GB060) — Compressor protection boards are used to control and protect compressors. One board is used for each compressor to control compressor contactor(s) and crankcase heater(s) in response to a command from microprocessor. The board also provides compressor ground current protection, shutting off compressor if a 2 to 3 ampere ground current is sensed by a toroid around the compressor power leads. A high-pressure protector and a discharge gas temperature protector are connected in series with CPCS board, so that if they open, compressor stops. Microprocessor senses this through feedback switch input.

The CPCS control system is available as an accessory on 30GB060. The 30GB060 unit is factory equipped with a control relay that operates same as CPCS except that ground current refrigerant circuit protection is not provided.

Complete electronic control system contains several additional components.

Relay board — Relay board, connected to microprocessor by a ribbon cable, drives all of 24-v, 115-v, or 230-v loads. Relays control compressors, fans, and unloaders, if used.

Display board — Display board, also connected to microprocessor by a ribbon cable, is used to communicate with operator. In addition to leaving water set point potentiometer, board contains 2-digit LED display. The LED display is normally off after initialization period, to extend its life. Pressing display button will result in LED displaying the appropriate overload or status code.

If this is done, display will show from one to 3 codes alternating every 2 seconds, as follows:

CODE	STATUS
1. 0-12	Capacity stage Number of stages in operation
2. 20-24	Operating Mode
20	Initialization
21	Temperature Reset
22	Demand Limit
24	Pulldown Control
3. 51-87	Overload Codes Alarm light/circuit energized. NOTE: These codes take priority.
51-58	Compressor fault
59,60	Loss of charge (circuit 1, circuit 2)
61	Low water flow
63,64	Low oil pressure (circuit 1, circuit 2)
65	Low water temperature
70	Illegal configuration
71-80	Thermistor failure
81-87	Reset/Set Point/Limit Failure

These codes are summarized on a chart in each unit's control box, and are described in detail in the Controls and Troubleshooting book.

Control sequence

Off cycle — During unit off cycle, crankcase and, if ambient temperature is below 36 F (2 C), cooler and control box heaters are energized. Electronic expansion valves are closed.

Start-up — After control circuit ON/OFF circuit breaker switched ON, prestart process takes place for 2 minutes, when microprocessor checks itself and waits for temperature to stabilize. First circuit to start may be no. 1 or 2, (automatic lead/lag feature). The controlled pull down feature limits compressor loading on start-up to reduce demand on start-up and unnecessary compressor usage. The microprocessor limits supply water temperature decrease (start-up only) to 1°F (0.6 C) per minute.

Capacity control — On first call for cooling, microprocessor starts initial compressor and fan stage on lead circuit. The electronic expansion valve remains closed for 10 seconds, permitting a pumpout on start-up. After pumpout, the valves open and, if necessary, additional outdoor fans are energized. Crankcase heaters are de-energized when a compressor is started. As additional cooling is required, lag circuit starts. If further cooling is needed, compressors are added, alternating between lead and lag circuits. Speed at which capacity is added or decreased is controlled by temperature deviation from set point and rate of temperature change of chilled water.

As less cooling is required, circuits shut down (or unload) in an order that evens out each circuit's compressor run time. When no further cooling is called for (in each compressor circuit), expansion valve closes and compressor and fans continue to run while pumping down cooler.

Low-temperature override feature prevents LCWT from overshooting the set point and possibly causing a nuisance trip-out by the freeze protection.

High-temperature override feature allows chiller to add capacity quickly during rapid load variations.

Demand limit — If applied, unit step controls limit total power draw of unit to selected point by controlling number of operational compressors during periods of peak electrical demand or time clock shutdown. Consult Accessory Demand Limit Control Module Installation Instructions for further details.

Reset accessory — If applied, microprocessor compares either return water, space or outdoor temperature with the accessory board settings, and adjusts leaving chilled water temperature appropriately.

Electronic expansion valve and outdoor fan control — Expansion valve opens and closes on signal from microprocessor to maintain an approximate 20 F (11 C) refrigerant superheat entering the compressor cylinders. (The compressor motor increases the refrigerant superheat from the approximate 5 F [3 C] leaving the cooler to that entering the cylinders.) Outdoor fans (operated by microprocessor) run to as low an ambient as possible to maintain a minimum expansion valve pressure differential.

Abnormal conditions (alarm light) — All control safeties in chiller operate through compressor protection board or control relay and microprocessor. High-pressure switch and discharge gas thermostat directly shuts down compressor(s) through compressor protection board or control relay. For other safeties, microprocessor (1) makes appropriate decision to shut down a compressor due to a safety trip or bad sensor reading (2) energizes *alarm light* and (3) displays appropriate failure code on the display. Chiller holds in safety mode until reset. It then reverts to normal control when unit is reset.

Safeties include: *Oil-pressure switch* cuts out if pressure differential is below minimum. Switch is bypassed on start-up for 45 seconds. *Loss-of-charge switch* cuts out if system pressure drops below minimum. *High-pressure switch* cuts out compressors if compressor discharge pressure increases to 395 psig (2724 kPa). *Discharge gas thermostat* opens when discharge gas temperature exceeds maximum 295 F (146 C). *Ground current safety* opens on sensing a current-to-ground in compressor windings in excess of 2.5 amps. *Loss of flow protection* provided by temperature differences between entering and leaving water temperature sensors. Flow switch is not required. *Freeze-up protection* provided by leaving water temperature sensor if cooler temperature drops to 35 F (1.8 C). *Sensor failures* are detected by the microprocessor.

Diagnostics — Microprocessor may be put through Quick Test (see Controls and Troubleshooting book) without additional equipment or tools. Quick Test confirms microprocessor is functional, informs observer through LED display the condition of each sensor and switch in chiller, and allows observer to check for proper operation of fans and compressor(s).

Typical installation

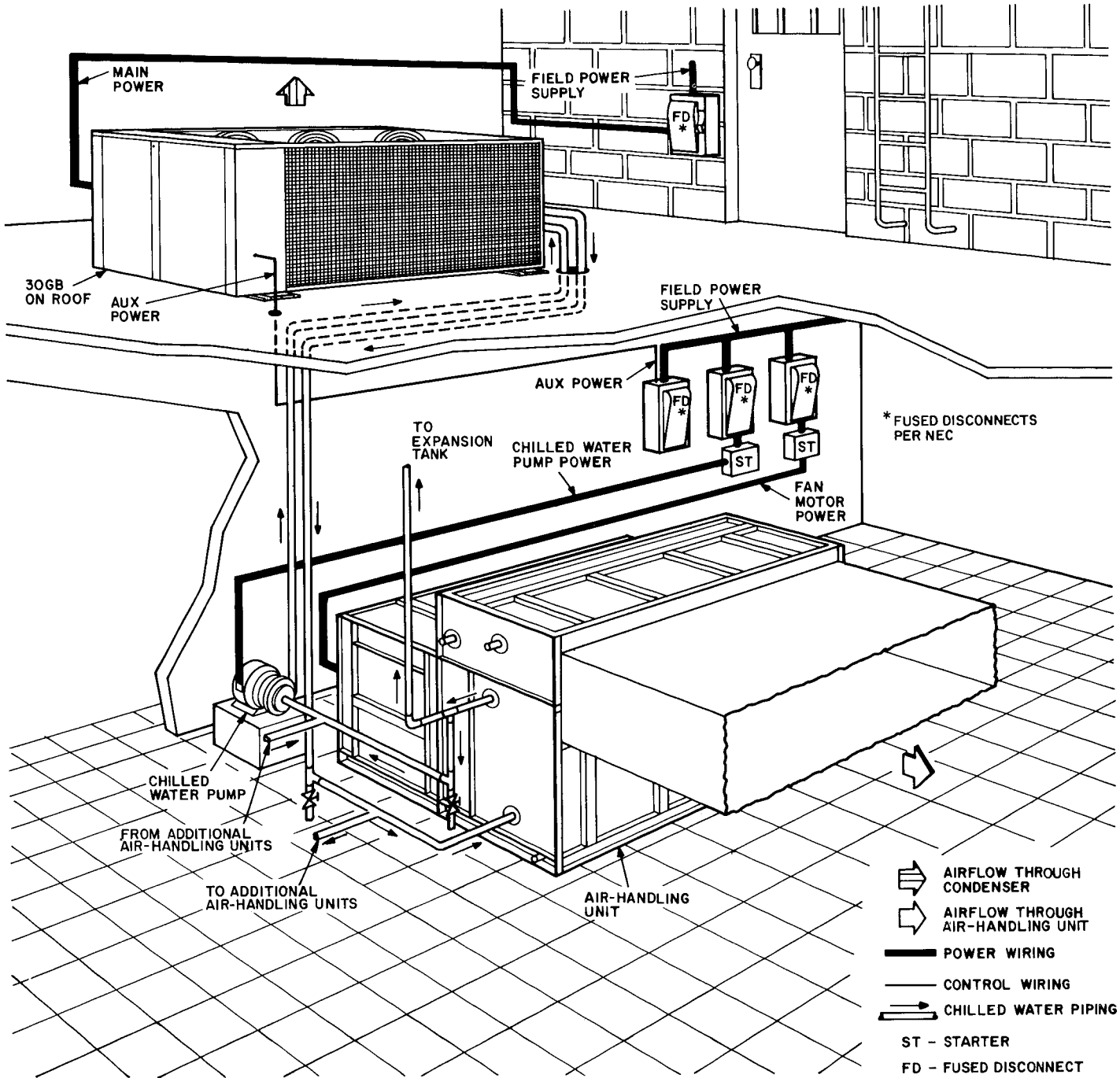

NOTES:

1. Wiring and piping shown are general points-of-connection guides only and are not intended for or to include all details for a specific installation.

- 2. All wiring must comply with applicable local and national codes
- 3. All piping must follow standard piping techniques. Refer to Carrier System Design Manual for details.

Guide specifications

1. GENERAL

- 1.1 Furnish and install complete, factory-assembled air-cooled reciprocating liquid chiller units of the type, size and capacity shown on the equipment schedules. Unit shall be for outdoor use and rated in accordance with ARI Standard 590 latest edition.
- 1.2 Equipment schedules and specifications are based on Carrier Model 30GB060.
- 1.3 Reciprocating liquid chillers specified in this section are of the air-cooled single-piece unit packaged type.
- 1.4 Units shall be of the packaged air-cooled type as shown on the drawings and consist of a reciprocating compressor or multiples thereof, direct-expansion liquid cooler, air-cooled condenser and factory wiring and piping contained within the unit enclosure. Unit shall contain a complete operating charge of refrigerant R-22.
- 1.5 Unit shall contain factory-installed diagnostic system, capable of indicating status of all safeties and energizing remote alarm.
- 1.6 Unit construction shall comply with ANSI B9.1 safety code, NEC (National Electrical Code) and ASME Code.
- 1.7 Unit shall be capable of starting with up to 95 F (35C) entering water temperature to the cooler.
- 1.8 Unit shall control leaving water temperature \pm _____ F (_____ C) from design point.
- 1.9 Unit shall be listed with UL.

2. UNIT CASING

- 2.1 Unit shall be enclosed in a galvanized steel casing, zinc phosphatized, and coated with a baked enamel finish, capable of withstanding Federal Test Method Standard No. 141 (Method 6061) 500-hour salt spray test.

3. COMPRESSOR

- 3.1 Each compressor shall be of the reciprocating serviceable hermetic type only, and shall be equipped with an automatically reversible oil pump, operating oil charge, suction and discharge shutoff valves, and shall be factory mounted on spring vibration isolators.
- 3.2 Compressor motor shall be cooled by suction gas passing around motor winding and shall be thermally protected. Manual restart shall be required after stoppage due to thermal and pressure overload.
- 3.3 Each compressor shall be equipped with an insert type crankcase heater factory sized to control oil dilution during shutdown.
- 3.4 Compressor speed shall not exceed 1750 rpm (29.2 rps).

4. COOLER

- 4.1 Cooler shall be shell-and-tube type, with removable heads. Seamless copper tubes shall be rolled into tube sheets.
- 4.2 Cooler shall be tested and stamped in accordance with ASME code for refrigerant side working pressure of 235 psig (1620 kPa) and a minimum water side working pressure of 150 psig (1034 kPa).

- 4.3 Shell shall be insulated with a minimum of 3/4-in. (19-mm) closed cell polyvinyl chloride (PVC) foam insulation of maximum K factor 0.28. Heaters along the shell, under the insulation, shall protect cooler against freeze-up down to 10 F (-12 C).

- 4.4 Cooler shall have 2 independent direct-expansion refrigerant circuits for all models.

5. CONDENSER

- 5.1 Air-cooled condenser coils shall have aluminum (copper) fins mechanically bonded to seamless copper tubes, cleaned, dehydrated, sealed, leak tested at 150 psig (1034 kPa) and pressure tested at 450 psig (3103 kPa).
- 5.2 Condenser fans shall be propeller type with PVC-coated steel wire safety guards, balanced statically and dynamically and discharge vertically.
- 5.3 Condenser fan motors shall have inherent over-current protection.

6. REFRIGERANT COMPONENTS

- 6.1 Refrigerant circuit components shall include hot-gas muffler, high side pressure relief device, liquid-line shutoff valve, replaceable-core filter drier, moisture indicating sight glass, and stepper motor actuated electronic expansion valve (or thermal expansion valve).
- 6.2 Expansion valves shall have maximum operating pressure characteristics to limit inlet suction pressure.
- 6.3 If unloaders are to be used, they shall be electrically actuated suction cutoff cylinder unloaders.
- 6.4 For 30GB060 units, gages are available as accessories.

7. CHILLER CONTROLS

- 7.1 Unit controls, including microprocessor, shall be factory mounted and wired in a weatherproof enclosure with hinged access doors for easy access. Unit shall have automatic lead-lag available with accessory unloader package. All units shall have pumpdown at beginning and end of every circuit cooling cycle, loss-of-charge protection, inherent low water flow protection, low chilled water temperature safety, low- and high-suction superheat protection for each circuit. Low oil pressure protection for each circuit, individual solid-state compressor protection board and ground current protection for each compressor are accessories for 30GB060. Unit shall have low control voltage to unit, field power and control circuit terminal blocks, compressor and fan motor circuit breakers, control circuit breaker, ON/OFF switch, replaceable relay board, leaving chilled water set point board, and a diagnostic digital display module, a microprocessor board, a temperature reset board (accessory).
- 7.2 Unit shall control capacity based upon leaving water temperature and will be compensated by return water temperature.
- 7.3 *Capacity control* — Chillers shall have no less than 4 steps of control.

Guide specifications (cont)

7.4 Electronic ground current sensing device shall be available as accessory for each compressor to monitor the compressor 3-phase power supply. It shall be activated when no more than 2.5 amps is measured to ground and shall deactivate the compressor to prevent formation of compressor contaminants.

8. ELECTRICAL REQUIREMENTS

8.1 Unit primary electrical power supply shall be connected at a single location on unit.

8.2 Unit shall be capable of operation on ____ volt, 3-phase, 60 cycle supply. Control voltage shall be provided by a separate single-phase power supply ____v. The unit (LRA) ICF shall not exceed ____amps.

8.3 Each compressor motor shall be operated and protected against electrical overload by means of definite-purpose contactors and calibrated, ambient-compensated, magnetic-trip circuit breakers. The circuit breakers shall open all 3 phases in the event of overload in any one phase, single phasing or phase reversal and shall be manually reset.

8.4 Electrical requirements for unit for sizing of wiring and overcurrent protection devices shall be selected to allow unit operation at ARI Standard 590, Section 8.1. *Maximum Loading Conditions* (115 F ambient temperature at 10% under voltage).

9. WARRANTY

9.1 The manufacturer shall provide a one-year parts warranty on the compressors (with optional 4-year extension) and a one-year parts warranty on other unit components.

Specifiers note — Application of 30GB outdoor chillers for brine duty within the 39.9 F to 34 F (4.4 C to 1°C) range is possible with proper field change of control configuration. Application in the range 34 F to 15 F (1°C to -9.4 C) requires 30GB unit with factory modification.