

Washer-Extractors

Cabinet Freestanding Installation and Operating Instructions

— Installation/Operation Supplement —



www.comlaundry.com

Part No. F232148R2EN
December 2007

Table of Contents

- Safety Information**..... 2
- Important Safety Instructions 2
- Installation**..... 4
- General Specifications 4
 - V-Computer 4
 - WE-6 Computer 6
- Dimensional Clearances 10
 - V-Computer 10
 - WE-6 Computer 10
- Dimensions 11
 - V-Computer 11
 - WE-6 Computer 13
- Operation**..... 21
- V-Computer 21
- WE-6 Computer 23
 - Loading Using Tilt Option..... 24
 - Unloading Using Tilt Option 24
- Disposal of Unit**..... 25

© Copyright 2007, Alliance Laundry Systems LLC
 All rights reserved. No part of the contents of this book may be reproduced or transmitted in any form or by any means without the expressed written consent of the publisher.

Safety Information

Precautionary statements (“DANGER,” “WARNING,” and “CAUTION”), followed by specific instructions, are found in this manual and on machine decals. These precautions are intended for the personal safety of the operator, user, servicer and those maintaining the machine.

	DANGER
DANGER indicates the presence of a hazard that will cause severe personal injury, death, or substantial property damage if the danger is ignored.	

	WARNING
WARNING indicates the presence of a hazard that can cause severe personal injury, death, or substantial property damage if the warning is ignored.	

	CAUTION
CAUTION indicates the presence of a hazard that will or can cause minor personal injury or property damage if the caution is ignored.	

Additional precautionary statements (“IMPORTANT” and “NOTE”) are followed by specific instructions.

IMPORTANT: The word “IMPORTANT” is used to inform the reader of specific procedures where minor machine damage will occur if the procedure is not followed.

NOTE: The word “NOTE” is used to communicate installation, operation, maintenance or servicing information that is important but not hazard related.

Important Safety Instructions

	WARNING
To reduce the risk of fire, electric shock, serious injury or death to persons when using your washer, follow these basic precautions:	
W023	

1. Read all instructions before using the washer.
2. Refer to the GROUNDING INSTRUCTIONS in the INSTALLATION manual for the proper grounding of the washer.
3. Do not wash textiles that have been previously cleaned in, washed in, soaked in, or spotted with gasoline, dry-cleaning solvents, or other flammable or explosive substances as they give off vapors that could ignite or explode.
4. Do not add gasoline, dry-cleaning solvents, or other flammable or explosive substances to the wash water. These substances give off vapors that could ignite or explode.
5. Under certain conditions, hydrogen gas may be produced in a hot water system that has not been used for two weeks or more. HYDROGEN GAS IS EXPLOSIVE. If the hot water system has not been used for such a period, before using a washing machine or combination washer-dryer, turn on all hot water faucets and let the water flow from each for several minutes. This will release any accumulated hydrogen gas. The gas is flammable; do not smoke or use an open flame during this time.
6. Do not allow children to play on or in the washer. Close supervision of children is necessary when the washer is used near children. This is a safety rule for all appliances.
7. Before the washer is removed from service or discarded, remove the door to the washing compartment.
8. Do not reach into the washer if the wash drum is moving.

9. Do not install or store the washer where it will be exposed to water and/or weather.
10. Do not tamper with the controls.
11. Do not repair or replace any part of the washer, or attempt any servicing unless specifically recommended in the user-maintenance instructions or in published user-repair instructions that the user understands and has the skills to carry out.
12. To reduce the risk of an electric shock or fire, DO NOT use an extension cord or an adapter to connect the washer to the electrical power source.
13. Use washer only for its intended purpose, washing textiles.
14. ALWAYS disconnect the washer from electrical supply before attempting any service. Disconnect the power cord by grasping the plug, not the cord.
15. Install the washer according to the INSTALLATION INSTRUCTIONS. All connections for water, drain, electrical power and grounding must comply with local codes and be made by licensed personnel when required.
16. To reduce the risk of fire, textiles which have traces of any flammable substances such as vegetable oil, cooking oil, machine oil, flammable chemicals, thinner, etc. or anything containing wax or chemicals such as in mops and cleaning cloths, must not be put into the washer. These flammable substances may cause the fabric to catch on fire by itself.
17. Do not use fabric softeners or products to eliminate static unless recommended by the manufacturer of the fabric softener or product.
18. Keep washer in good condition. Bumping or dropping the washer can damage safety features. If this occurs, have washer checked by a qualified service person.
19. Replace worn power cords and/or loose plugs.
20. Be sure water connections have a shut-off valve and that fill hose connections are tight. CLOSE the shut-off valves at the end of each wash day.
21. Loading door MUST BE CLOSED anytime the washer is to fill, tumble or spin. DO NOT bypass the loading door switch by permitting the washer to operate with the loading door open.
22. Always read and follow manufacturer's instructions on packages of laundry and cleaning aids. Heed all warnings or precautions. To reduce the risk of poisoning or chemical burns, keep them out of the reach of children at all times (preferably in a locked cabinet).
23. Always follow the fabric care instructions supplied by the textile manufacturer.
24. Never operate the washer with any guards and/or panels removed.
25. DO NOT operate the washer with missing or broken parts.
26. DO NOT bypass any safety devices.
27. Failure to install, maintain, and/or operate this washer according to the manufacturer's instructions may result in conditions which can produce bodily injury and/or property damage.

NOTE: The WARNING and IMPORTANT SAFETY INSTRUCTIONS appearing in this manual are not meant to cover all possible conditions and situations that may occur. Common sense, caution and care must be exercised when installing, maintaining, or operating the washer.

Any problems or conditions not understood should be reported to the dealer, distributor, service agent or the manufacturer.

Installation

General Specifications

V-Computer

SF18VNV, SF25VNV, UF18VNV, and UF25VNV Models

Refer to *Table 1*.

	18 Pound	25 Pound	
Overall Dimensions			
Overall width, mm (in.)	737 (29.0)	813 (32.0)	
Overall height, mm (in.)	1168 (46.0)	1232 (48.5)	
Overall depth, mm (in.)	833 (32.8)	940 (37.0)	
Weight and Shipping Information			
Net weight, kg (lbs.)	250 (550)	318 (700)	
Domestic shipping weight, kg (lbs.)	250 (550)	341 (750)	
Domestic shipping volume, m ³ (ft ³)	0.98 (34.6)	N/A	
Export shipping weight, kg (lbs.)	272 (600)	363 (800)	
Export shipping volume, m ³ (ft ³)	1.17 (41.44)	N/A	
Wash Cylinder Information			
Cylinder diameter, mm (in.)	533 (21.0)	610 (24.0)	
Cylinder depth, mm (in.)	349 (13.75)	406 (16.0)	
Cylinder volume, l (ft ³)	78 (2.76)	119 (4.19)	
Perforation size, mm (in.)	4.77 (0.188)	4,77 (0.188)	
Perforation open area, %	23	23	
Load capacity (dry cloth weight), kg (lbs.)	8.16 (18)	11.34 (25)	
Door Opening Information			
Door opening size, mm (in.)	305 (12.0)	364 (14.345)	
Height of door bottom above floor, mm (in.)	518 (20.4)	511 (20.1)	
Water Consumption			
Average water consumption per cycle, l (gal.)	HOT	87 (23)	106 (28)
	COLD	42 (11)	49 (13)

Table 1 (Continued)

Table 1 (Continued)

	18 Pound	25 Pound	
Power Consumption			
Average power used per cycle, kWh	0.2	0.3	
Nominal sound emission, dBA	58	Data not available	
Average HVAC load, kcal/hr (Btu/hr)	101 (400)	113 (450)	
Drive Train Information			
Number of motors in drive train	1	1	
Drive motor power, kW (HP)	0.75 (1.0)	1.50 (2.0)	
Cylinder Speeds			
Low wash/reverse speed, RPM	29	27	
Normal wash/reverse speed, RPM	52	49	
Distribution speed, RPM	86	73	
Extract 1, RPM	534	500	
Extract 2, RPM	685	641	
Extract 3, RPM	1080	1011	
Centrifugal Force Data			
Low wash/reverse centrifugal force, Gs	0.25	0.80	
Normal wash/reverse centrifugal force, Gs	0.80	0.80	
Distribution centrifugal force, Gs	2.20	1.80	
Extract 1 centrifugal force, Gs	85	85	
Extract 2 centrifugal force, Gs	140	140	
Extract 3 centrifugal force, Gs	348	348	
Load Balancing			
Balance detection system	AC drive	AC drive	
Direct Steam Heating (Optional)			
Steam inlet connection size, mm (in.)	DN15 (1/2 NPT)	DN15 (1/2 NPT)	
Number of steam inlets	1	1	
Steam required to raise bath temperature 10 °C, kg (10 °F, lb.)	LOW	0.81 (1.13)	1.05 (1.46)
	MED	0.90 (1.25)	1.16 (1.61)
	HIGH	1.04 (1.45)	1.33 (1.85)
Average steam use per cycle, kg (bhp)	11.7 (0.75)	15 (0.96)	

WE-6 Computer

SF35PV, SF50PV, SF85PV, UF35PV, UF50PV, and UF85PV Models

Refer to *Table 2*.

	35 Pound	50 Pound	85 Pound	
Overall Dimensions				
Overall width, mm (in.)	889 (35)	990 (39)	1181 (46.5)	
Overall height, mm (in.)	1407 (55.4)	1514 (59.6Z)	1781 (70.1)	
Overall depth, mm (in.)	992 (39)	1049 (41.3)	1270 (50)	
Weight and Shipping Information				
Net weight, kg (lbs.)	550 (1212)	726 (1600)	1362 (3000)	
Domestic shipping weight, kg (lbs.)	572 (1260)	749(1650)	1407 (3100)	
Domestic shipping volume, m ³ (ft ³)	1.80 (63.6)	2.26 (80)	3.46 (123)	
Export shipping weight, kg (lbs.)	580 (1275)	1750 (795)	3200 (1453)	
Export shipping volume, m ³ (ft ³)	1.85 (65.3)	2.36 (83.5)	3.86 (137)	
Wash Cylinder Information				
Cylinder diameter, mm (in.)	668 (26.25)	762 (30)	914 (36)	
Cylinder depth, mm (in.)	467 (18.375)	508 (20)	61 (240)	
Cylinder volume, l (ft ³)	164 (5.79)	232 (8.19)	400 (14.1)	
Perforation size, mm (in.)	0.188 (4.77)	0.188 (4.77)	4.77 (0.188)	
Perforation open area, %	23	23	23	
Door Opening Information				
Door opening size, mm (in.)	354 (13.9)	413 (16.25)	445 (17.5)	
Height of door bottom above floor, mm (in.)	636 (25)	23 (585)	32.7 (831)	
Water Consumption				
Average water consumption per cycle, l (gal.)	HOT	47 (178)	216 (57)	407 (108)
	COLD	79 (21)	98 (26)	190 (50)
Average hot water consumed per hour, l (gal.)	276 (73)	322 (85)	579 (153)	
Power Consumption				
Average power used per cycle, kWh	0.4	0.6	0.9	
Average HVAC load, kcal/hr (Btu/hr)	125 (500)	213 (850)	300 (1200)	
Nominal sound emission, dBA	70	76	75	
Background noise level, dBA	54	49	55	
Drive Train Information				
Number of motors in drive train	1	1	1	
Drive motor power, kW (HP)	2.2 (3)	3.7 (5.0)	5.6 (7.5)	

Table 2 (Continued)

Table 2 (Continued)

		35 Pound	50 Pound	85 Pound
Cylinder Speeds				
Gentle wash/reverse speed, RPM		26	26	26
Wash/reverse speed, RPM		43	40	41
Distribution/drain speed, RPM		77	73	65
Medium extract speed, RPM		325	305	280
High extract speed 1, RPM		475	445	410
High extract speed 2, RPM		610	575	525
High extract speed 3, RPM		960	900	825
Centrifugal Force Data				
Gentle wash/reverse centrifugal force, Gs		0.25	0.29	0.345
Wash/reverse centrifugal force, Gs		0.69	0.68	0.858
Distribution/drain centrifugal force, Gs		2.2	2.3	2.16
Medium extract centrifugal force, Gs		40	40	40
High extract 1 centrifugal force, Gs		85	84	85.8
High extract 2 centrifugal force, Gs		140	141	141
High extract 3 centrifugal force, Gs		345	345	348
Balance Detection				
Vibration safety switch installed		Standard	Standard	Standard
Direct Steam Heating (Optional)				
Steam inlet connection size, mm (in.)	DN15	DN15 (0.5)	DN15 (0.5)	DN15 (0.5)
Number of steam inlets		1	1	1
Steam required to raise bath temperature 10°C, kg (10°F, lb.)	LOW	2.22 (1.6)	2.91 (2.42)	3.8 (5.2)
	MED	2.52 (1.81)	2.42 (3.46)	4.3 (5.9)
	HIGH	2.84 (2.04)	2.73 (3.80)	4.9 (6.9)
Average steam use per cycle, kg (bhp)		1.47 (23)	1.95 (30.6)	54.9 (3.5)
Electric Heating (Optional)				
Total electric heating capacity, kW		15.6	23.4	31.2
Number of electrical heat elements		6	9	12
Electrical heat element size, kW		2.6	2.6	2.6
Time required to raise bath temperature 10°C, min. (10°F, min.)	LOW	3.9 (2.6)	3.6 (2.4)	3.1 (4.8)
	MED	4.5 (2.9)	4.2 (2.7)	3.5 (5.4)
	HIGH	5.0 (3.3)	4.7 (3.1)	6.4 (4.1)

Installation/Operation Supplement

SF135PV, SF250PV, UF135PV, and UF250PV Models

Refer to *Table 3*.

	135 Pound	250 Pound		
	Standard	Standard	Forward Tilt Option	Two-Way Tilt Option
Overall Dimensions				
Overall width, mm (in.)	1803 (71)	1957 (77)	2006 (79)	2006 (79)
Overall height, mm (in.)	1829 (75)	2083 (82)	2235 (88)	2235 (88)
Overall depth, mm (in.)	1537 (60.5)	2235 (88)	2243 (88.3)	2311 91()
Weight and Shipping Information				
Net weight, kg (lbs.)	1818 (4000)	3661 (8070)	4000 (8800)	4355 (9600)
Domestic shipping weight, kg (lbs.)	1909 (4200)	3951 (8270)	4000 (8800)	4445 (9800)
Domestic shipping volume, m ³ (ft ³)	6.35 (227)	11.5 (409)	11.5 (409)	11.5 (409)
Export shipping weight, kg (lbs.)	2045 (4500)	3860 (8500)	4227 (9300)	4581 (10,100)
Export shipping volume, m ³ (ft ³)	6.39 (248)	11.5 (409)	11.5 (409)	11.5 (409)
Wash Cylinder Information				
Cylinder diameter, mm (in.)	1092 (43)	1321 (52)	1321 (52)	1321 (52)
Cylinder depth, mm (in.)	635 (25)	813 (32)	813 (32)	813 (32)
Cylinder volume, l (ft ³)	596 (21.0)	1114 (39.3)	1114 (39.3)	1114 (39.3)
Perforation size, mm (in.)	4.77 (0.188)	4.76 (0.188)	4.76 (0.188)	4.76 (0.188)
Perforation open area, %	23	20	20	20
Door Opening Information				
Door opening size, mm (in.)	584 (23)	724 (28.5)	724 (28.5)	724 (28.5)
Height of door bottom above floor, mm (in.)	718 (28.25)	784 (30.9)	937 (36.9)	937 (36.9)
Water Consumption				
Average water consumption per cycle, l (gal.)	HOT	590 (156)	905 (239)	905 (239)
	COLD	437 (116)	424 (112)	424 (112)
Average hot water consumed per hour, l (gal.)		1023 (270)	1355 (358)	1355 (358)
Power Consumption				
Average power used per cycle, kWh		0.9	1.5 (Est.)	1.5 (Est.)
Average HVAC load, kcal/hr (Btu/hr)		375 (1500)	550 (2200)	550 (2200)
Nominal sound emission, dBA		75	75	N/A
Drive Train Information				
Number of motors in drive train		1	1	1
Drive motor power, kW (HP)		7.5 (10)	18.5 (25)	18.5 (25)

Table 3 (Continued)

Table 3 (Continued)

		135 Pound	250 Pound		
		Standard	Standard	Forward Tilt Option	Two-Way Tilt Option
Cylinder Speeds					
1/2 Wash/reverse speed, RPM		26	21	21	21
Wash/reverse speed, RPM		36	31	31	31
Distribution speed, RPM		62	54	54	54
Medium extract speed, RPM		170	140	140	140
High extract speed 1, RPM		375	340	340	340
High extract speed 2, RPM		480	435	435	435
High extract speed 3, RPM		715	650	650	650
Centrifugal Force Data					
1/2 Wash/reverse centrifugal force, Gs		0.412	0.325	0.325	0.325
Wash/reverse centrifugal force, Gs		0.790	0.708	0.708	0.708
Distribution centrifugal force, Gs		2.34	2.15	2.15	2.15
Medium extract centrifugal force, Gs		17.6	14.7	14.7	14.7
High extract 1 centrifugal force, Gs		85.8	86.9	86.9	86.9
High extract 2 centrifugal force, Gs		141	142	142	142
High extract 3 centrifugal force, Gs		312	318	318	318
Balance Detection					
Vibration safety switch installed		Standard	Standard	Standard	Standard
Direct Steam Heating (Optional)					
Steam inlet connection size, mm (in.)		DN19 (0.75)	DN25 (1.0)	DN25 (1.0)	DN25 (1.0)
Number of steam inlets		1	1	1	1
Steam required to raise bath temperature 10 °C, kg (10 °F, lb.)	LOW	3.11 (6.84)	5.23 (11.5)	5.23 (11.5)	5.23 (11.5)
	HIGH	4.40 (9.67)	7.91 (17.4)	17.4 (7.91)	17.4 (7.91)
Average steam use per cycle, bhp		4.78	9.0	9.0	9.0
Electric Heating (Optional)					
Total electric heating capacity, kW		45	N/A	N/A	N/A
Number of electrical heat elements		18	N/A	N/A	N/A
Electrical heat element size, kW		2.5	N/A	N/A	N/A
Time required to raise bath temperature 10°C, min. (10°F, min.)	LOW	5.0 (3.2)	N/A	N/A	N/A
	HIGH	6.4 (4.2)	N/A	N/A	N/A

Dimensional Clearances

NOTE: The dimensions shown here are for planning purposes only. They are approximate and subject to normal manufacturing tolerances. If exact dimensions are required for construction purposes, contact the distributor or manufacturer. We reserve the right to make changes at any time without notice.

V-Computer

SF18VNV, SF25VNV, UF18VNV, and UF25VNV Models

Both single and multiple machine installations require specified minimum clearances on all sides of each machine. Tables below show these clearances.

Recommended Minimum Clearances		
	18 Pound	25 Pound
Minimum rear clearance, mm (in.)	305 (12)	305 (12)
Minimum clearance between machine and wall, mm (in.)	50 (2)	50 (2)
Minimum clearance between machines (side), mm (in.)	25 (1)	25 (1)
Minimum front clearance, mm (in.)	406 (16)	445 (17.5)

Table 4

WE-6 Computer

SF35-85PV, UF35-85PV, SF135-250PV, and UF135-250PV Models

Recommended Minimum Clearances							
	35 Pound	50 Pound	85 Pound	135 Pound	250 Pound		
				Standard	Standard	Forward Tilt Option*	Two-Way Tilt Option*
Minimum rear clearance, mm (in.)	450 (18)	450 (18)	450 (18)	610 (24)	610 (24)	914 (36)	914 (36)
Minimum clearance between machine and wall, mm (in.)	150 (6)	150 (6)	150 (6)	457 (18)	457 (18)	457 (18)	457 (18)
Minimum clearance between machines (side), mm (in.)	25.4 (1)	25.4 (1)	25.4 (1)	457 (18)	457 (18)	457 (18)	457 (18)
Minimum front clearance, mm (in.)	533 (21)	584 (23)	584 (23)	584 (23)	914 (36)	914 (36)	914 (36)

* Machines equipped with the tilt option require a minimum overhead clearance as well. Refer to *Figure 7* for the minimum overhead clearance for the 250 pound capacity model with tilt option.

Table 5

Dimensions

V-Computer

SF18VNV, UF18VNV, SF25VNV, and UF25VNV Models

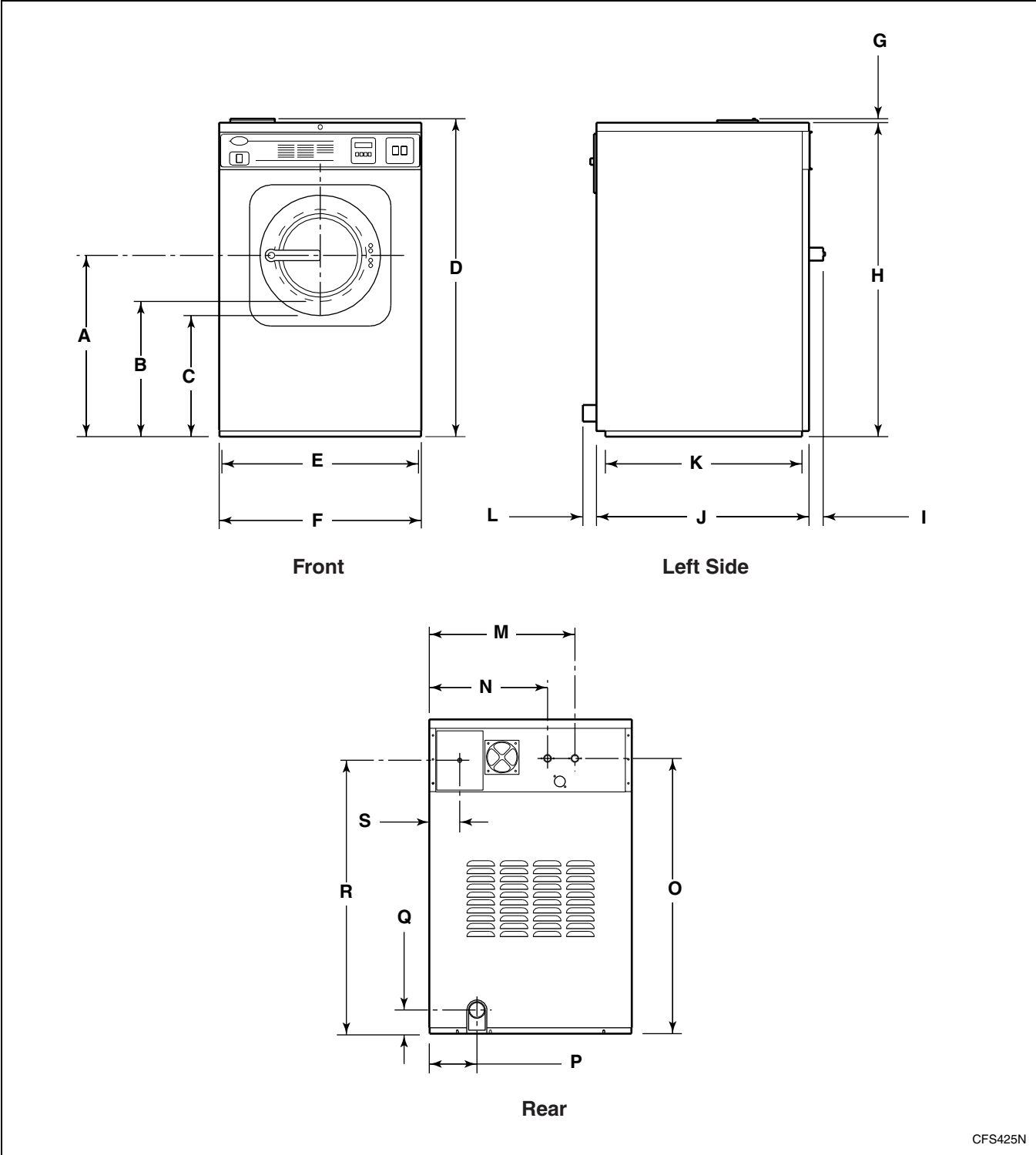

Figure 1

CFS425N

Installation/Operation Supplement

	18 Pound	25 Pound
A	659 mm (26 in.)	686 mm (27 in.)
B	492 mm (19-13/32 in.)	508 mm (20 in.)
C	440 mm (17-5/16 in.)	432 mm (17 in.)
D	1161 mm (45-23/32 in.)	1232 mm (48-1/2 in.)
E	686 mm (27 in.)	762 mm (30 in.)
F	737 mm (29 in.)	813 mm (32 in.)
G	18 mm (23/32 in.)	18 mm (23/32 in.)
H	1143 mm (45 in.)	1214 mm (47-13/16 in.)
I	25 mm (1 in.)	25 mm (1 in.)
J	774 mm (30-1/2 in.)	876 mm (34-1/2 in.)
K	709 mm (27-15/16 in.)	816 mm (32-1/8 in.)
L	33 mm (1-5/16 in.)	38 mm (1-1/2 in.)
M	530 mm (20-29/32 in.)	597 mm (23-1/2 in.)
N	430 mm (16-29/32 in.)	495 mm (19-1/2 in.)
O	1074 mm (42-5/16 in.)	1074 mm (42-5/16 in.)
P	173 mm (6-13/16 in.)	211 mm (8-5/16 in.)
Q	86 mm (3-13/32 in.)	86 mm (3-13/32 in.)
R	1029 mm (40-1/2 in.)	1067 mm (42 in.)
S	114 mm (4-1/2 in.)	4-13/16 in. (122 mm)

WE-6 Computer

SF35PV and UF35PV Models

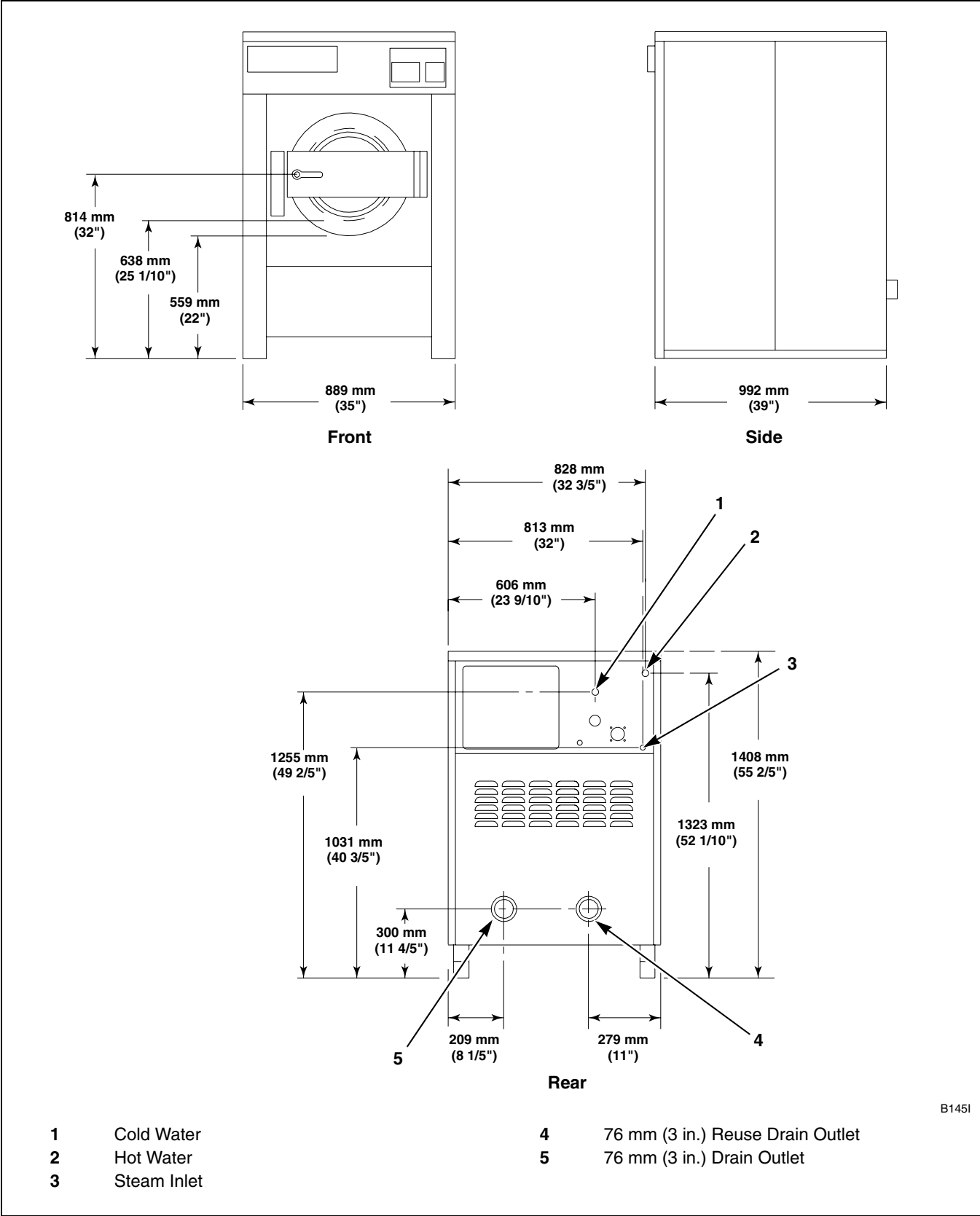

B145I

Figure 2

Installation/Operation Supplement

SF50PV, UF50PV, SF85PV, and UF85PV Models

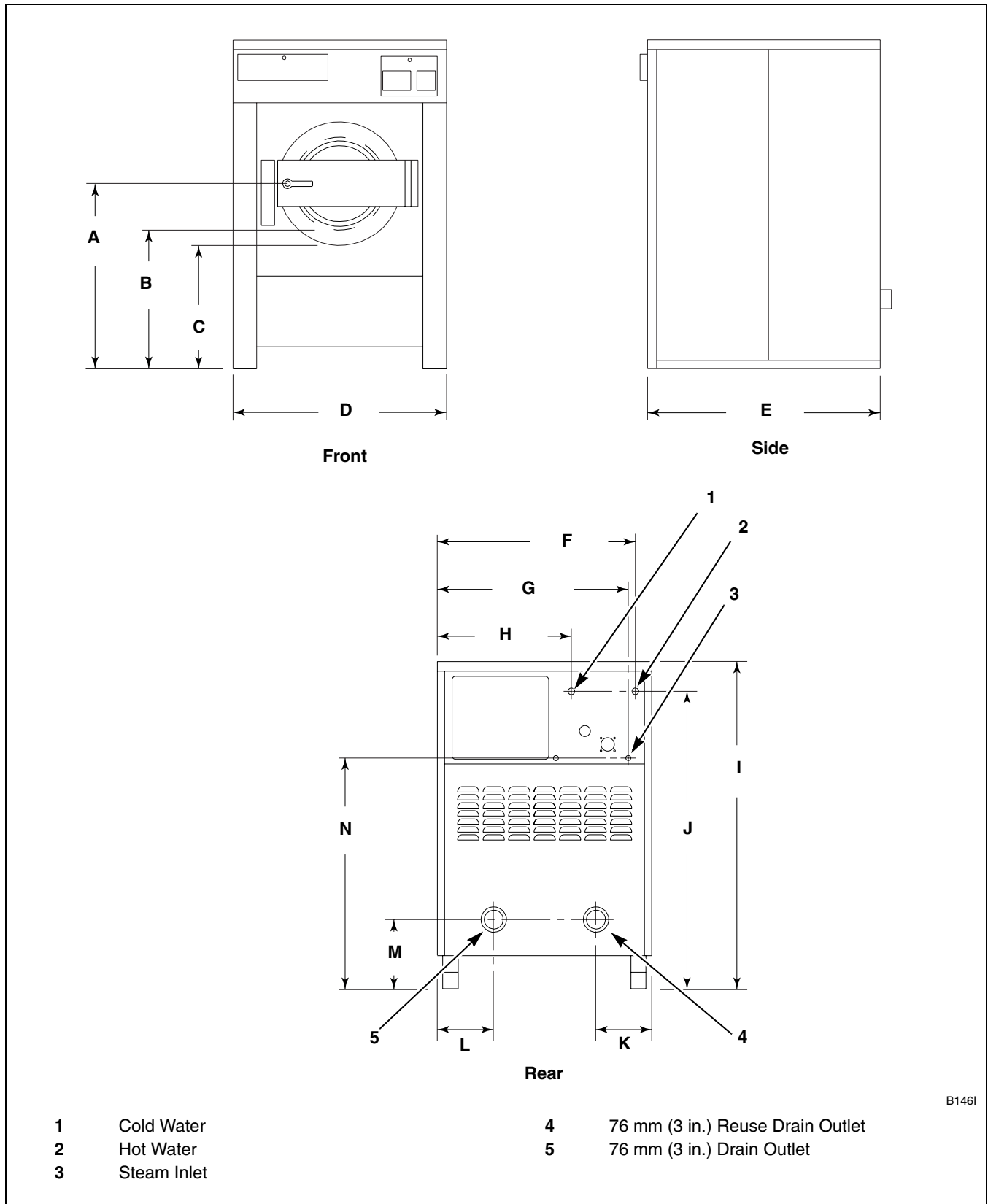

B146I

Figure 3

	50 Pound	85 Pound
A	872 mm (34-3/10 in.)	1054 mm (41-1/2 in.)
B	26-1/5 in. (666 mm)	831 mm (32-7/10 in.)
C	582 mm (22-9/10 in.)	765 mm (30-1/10 in.)
D	991 mm (39 in.)	1181 mm (46-1/2 in.)
E	1049 mm (41-3/10 in.)	1270 mm (50 in.)
F	930 mm (36-3/5 in.)	1107 mm (43-3/5 in.)
G	889 mm (35 in.)	1083 mm (42-3/5 in.)
H	619 mm (24-2/5 in.)	758 mm (29-9/10 in.)
I	1513 mm (59-3/5 in.)	1781 mm (70-1/10 in.)
J	1399 mm (55-1/10 in.)	1685 mm (66-2/5 in.)
K	260 mm (10-1/5 in.)	254 mm (10 in.)
L	260 mm (10-1/5 in.)	197 mm (7-3/4 in.)
M	300 mm (11-4/5 in.)	281 mm (11-1/10 in.)
N	1136 mm (44-7/10 in.)	1328 mm (52-3/8 in.)

Installation/Operation Supplement

135 Pound Capacity Models

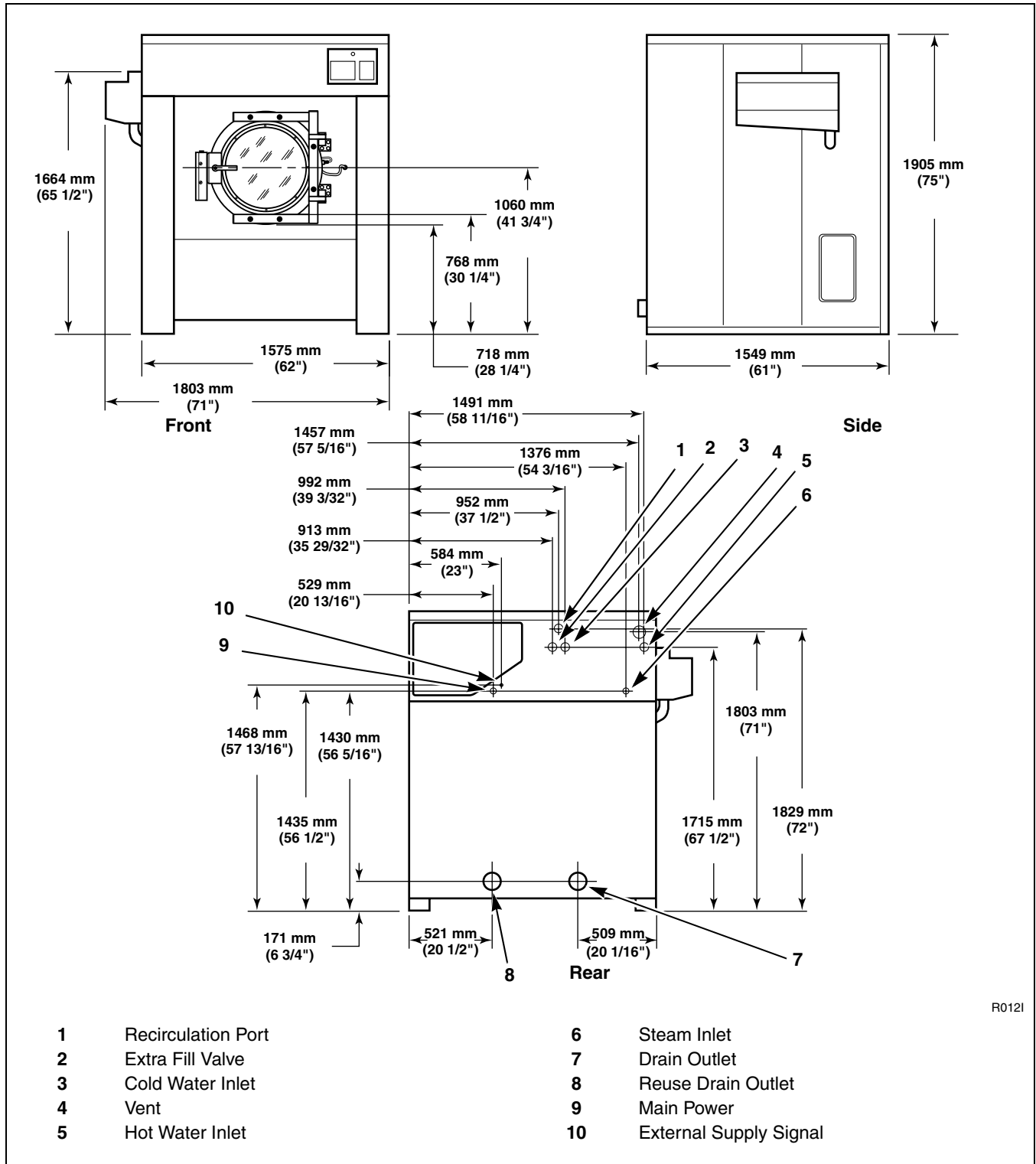

Figure 4

R012I

250 Pound Capacity Models

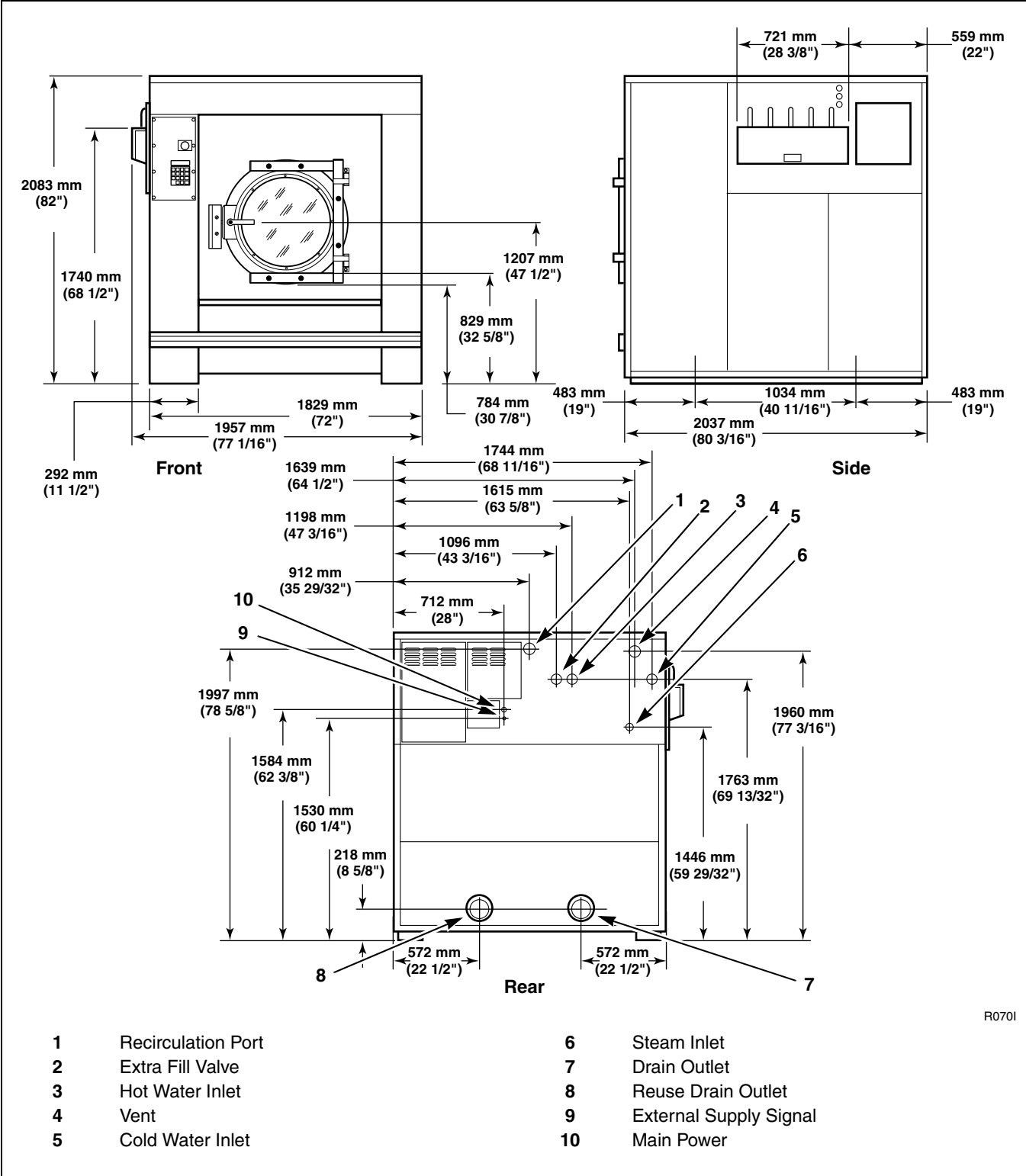
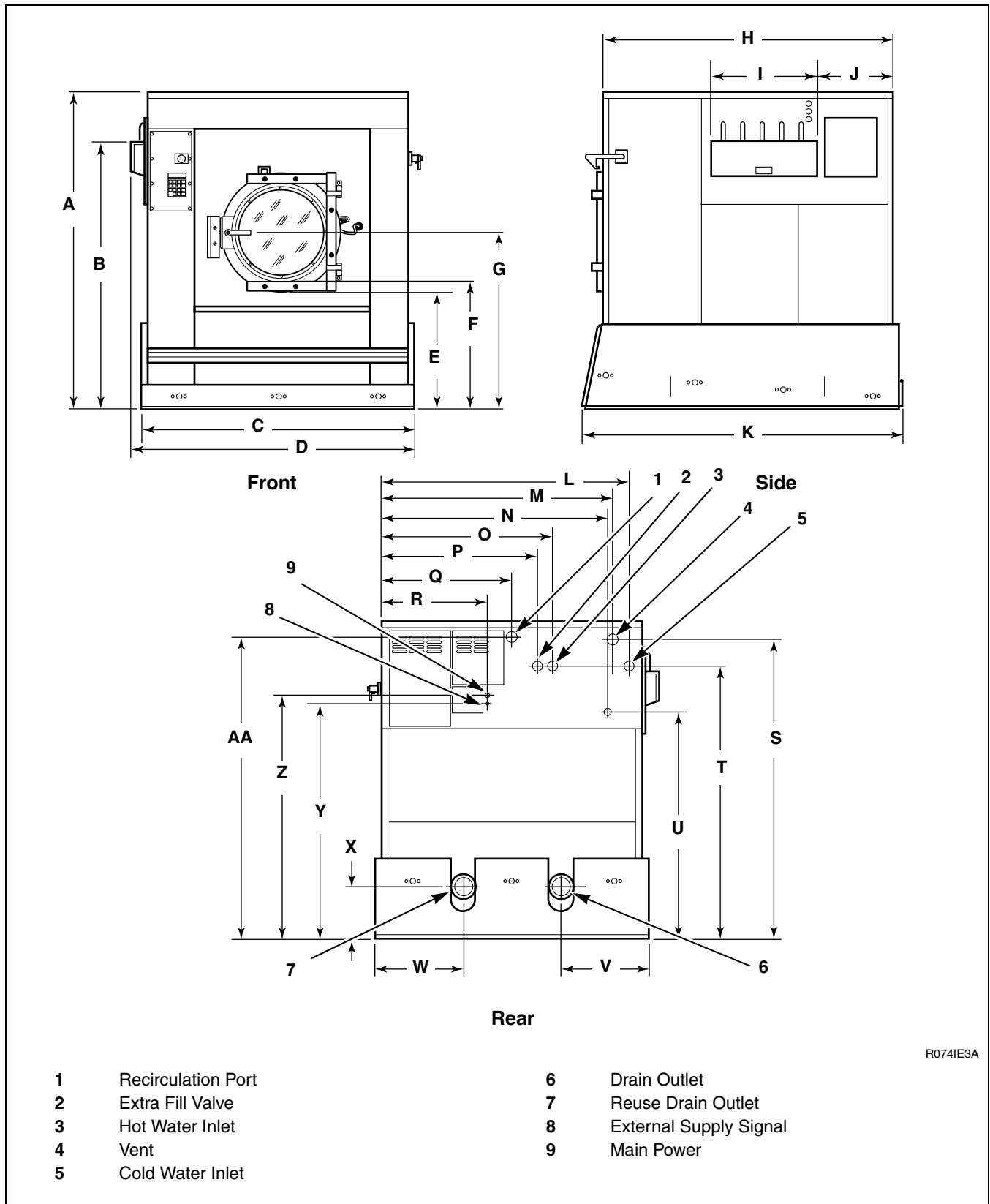

Figure 5

R0701

Installation/Operation Supplement

*250 Pound Capacity Models
with Forward Tilt or Two-Way Tilt Option*



R074IE3A

Figure 6

	Forward Tilt	Two-Way Tilt
A	2235 mm (88 in.)	2235 mm (88 in.)
B	1736 mm (74-13/32 in.)	1736 mm (74-13/32 in.)
C	1930 mm (76 in.)	1930 mm (76 in.)
D	2057 mm (81 in.)	2006 mm (79 in.)
E	936 mm (36-7/8 in.)	936 mm (36-7/8 in.)
F	981 mm (38-19/32 in.)	981 mm (38-5/8 in.)
G	1359 mm (53-1/2 in.)	1359 mm (53-1/2 in.)
H	2037 mm (80-3/16 in.)	2037 mm (80-3/16 in.)
I	721 mm (28-3/8 in.)	721 mm (28-3/8 in.)
J	559 mm (22 in.)	559 mm (22 in.)
K	2254 mm (88-3/4 in.)	2311 mm (91 in.)
L	1174 mm (68-11/16 in.)	1174 mm (68-11/16 in.)
M	1639 mm (64-1/2 in.)	1639 mm (64-1/2 in.)
N	1615 mm (63-5/8 in.)	1615 mm (63-5/8 in.)
O	1198 mm (47-3/16 in.)	1198 mm (47-3/16 in.)
P	1096 mm (43-3/16 in.)	1096 mm (43-3/16 in.)
Q	912 mm (35-29/32 in.)	912 mm (35-29/32 in.)
R	712 mm (28 in.)	712 mm (28 in.)
S	2121 mm (83-1/2 in.)	2121 mm (83-1/2 in.)
T	1930 mm (76 in.)	1930 mm (76 in.)
U	1613 mm (63-1/2 in.)	1613 mm (63-1/2 in.)
V	620 mm (24-13/32 in.)	620 mm (24-13/32 in.)
W	620 mm (24-13/32 in.)	620 mm (24-13/32 in.)
X	370 mm (14-5/8 in.)	370 mm (14-5/8 in.)
Y	1683 mm (66-1/4 in.)	1683 mm (66-1/4 in.)
Z	1737 mm (68-3/8 in.)	1737 mm (68-3/8 in.)
AA	2149 mm (84-5/8 in.)	2149 mm (84-5/8 in.)

Installation/Operation Supplement

*250 Pound Capacity Models
with Forward and Two-Way Tilt Option*

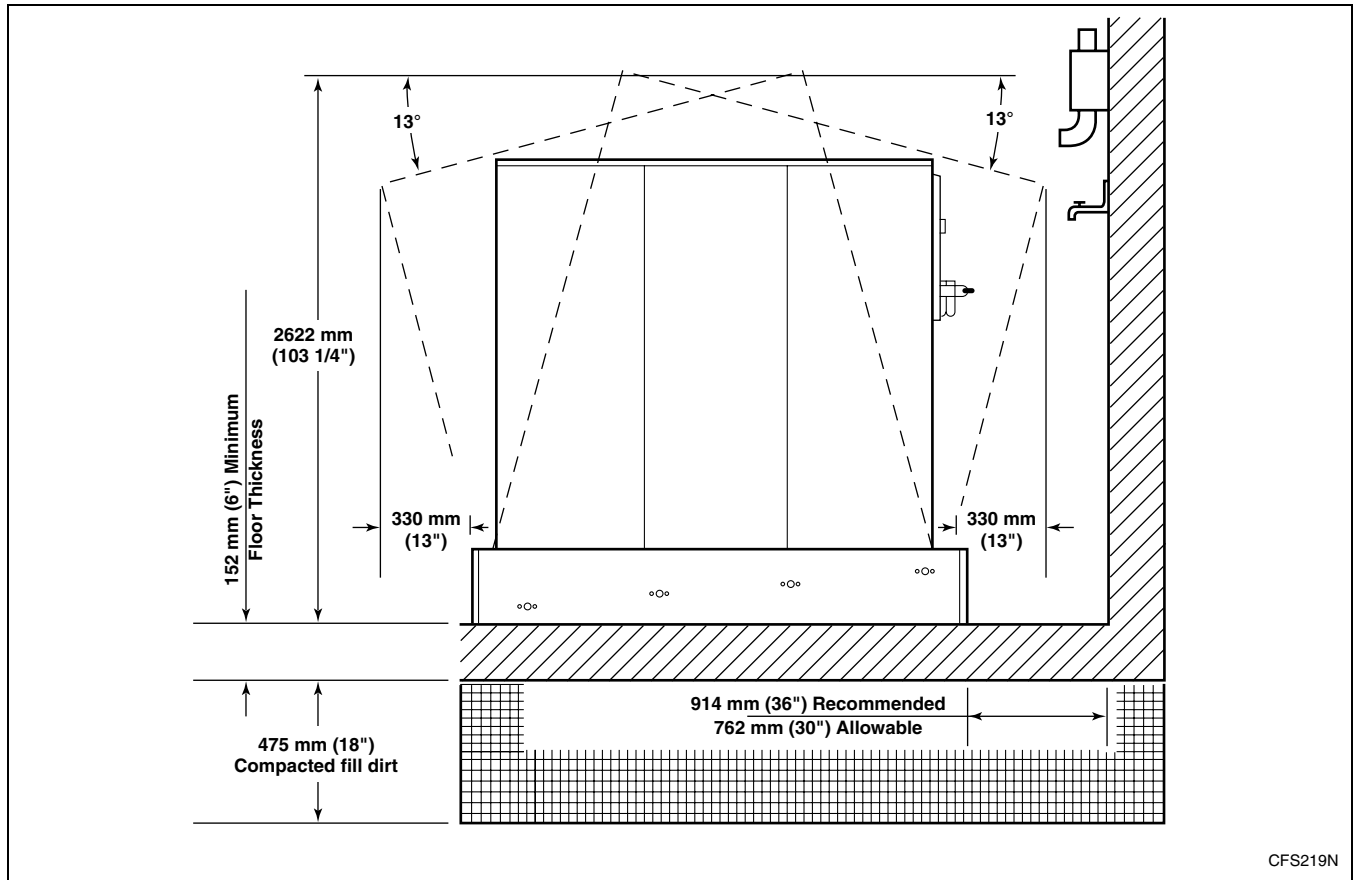

Figure 7

Operation

V-Computer

1. Turn on main power source (circuit breaker).
2. Turn on the ON/OFF switch on the front panel to the ON position. Refer to *Figure 9*.
3. Push button and turn handle clockwise. Refer to *Figure 8*.

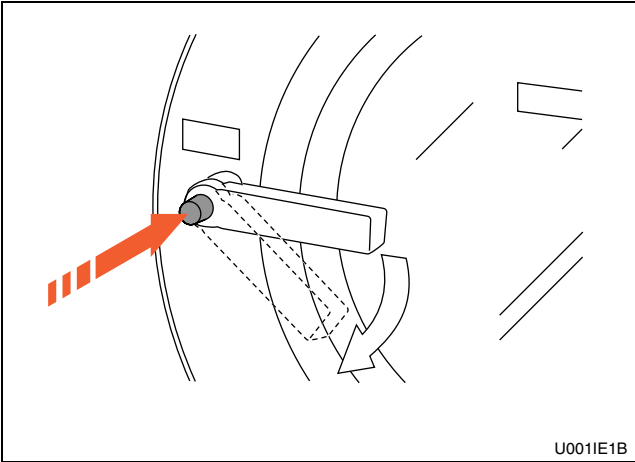

Figure 8

4. Press and hold the DOOR UNLOCK button on the left side of the control panel while performing the above step. Refer to *Figure 8* and *Figure 9*.

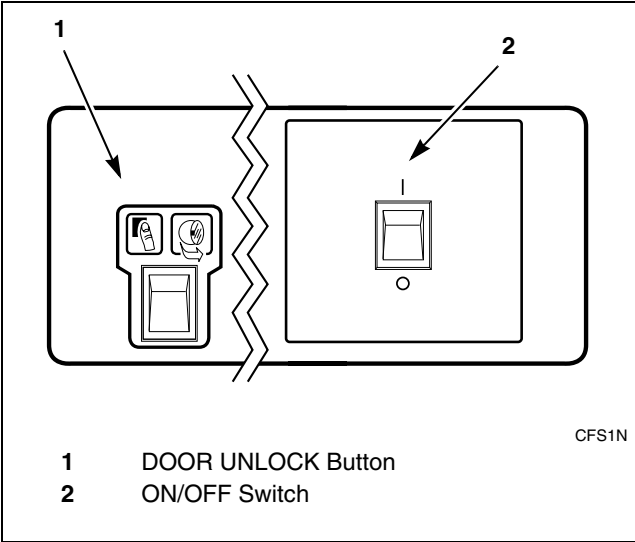

Figure 9

5. Load to capacity whenever possible. DO NOT OVERLOAD. Refer to *Figure 10*.

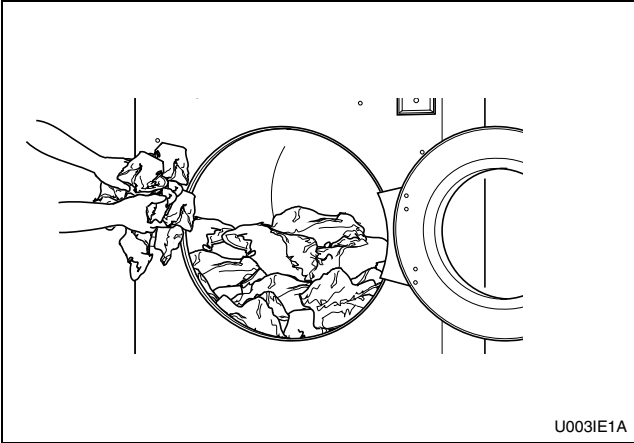

Figure 10

6. Close door and turn handle counterclockwise until button pops out. Refer to *Figure 11*.

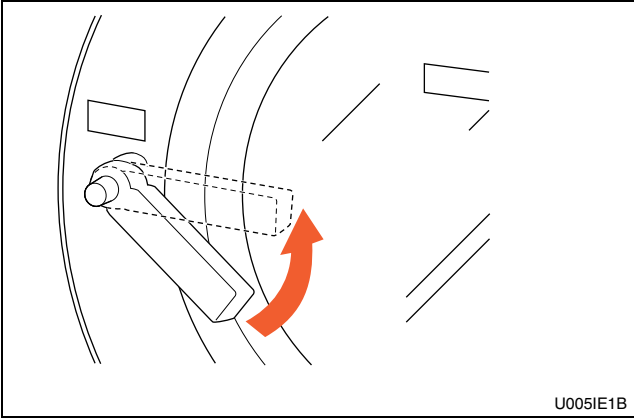

Figure 11

Installation/Operation Supplement

7. Add liquid and/or powder supplies to supply dispenser. Refer to *Figure 12*.
 - a. Add detergent to container 1.
 - b. Add detergent or bleach to container 2.
 - c. Add softener to container 3.

NOTE: Liquid supplies may be injected directly into the supply dispenser by an external chemical supply dispenser. Refer to Installation and Programming manuals.

8. Press the START key. Refer to *Figure 13*.

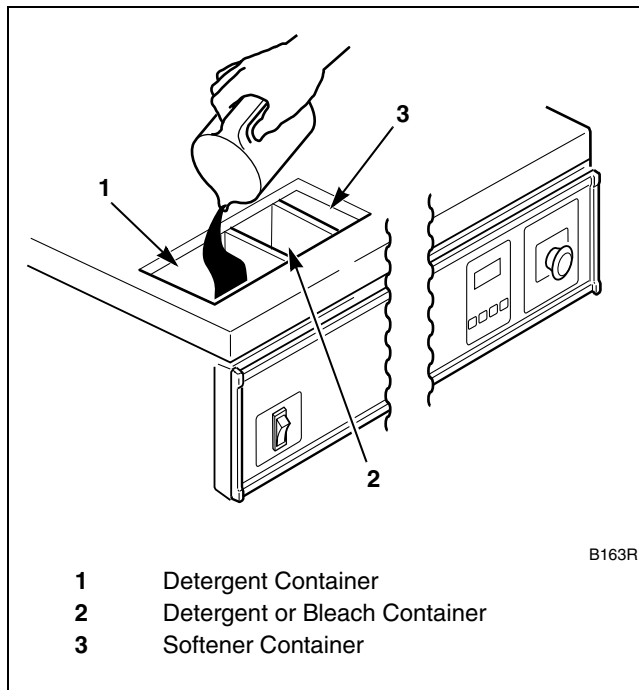

Figure 12

9. Press the UP and DOWN keys to select wash cycle. Press the START key. Refer to *Figure 13*.

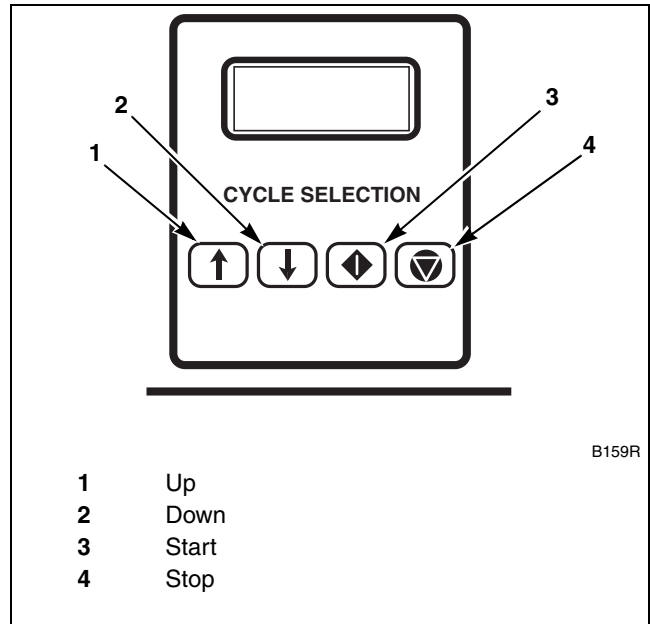

Figure 13

10. **When applicable**, add bleach when the display reads “bLCH”. Refer to *Figure 14*.

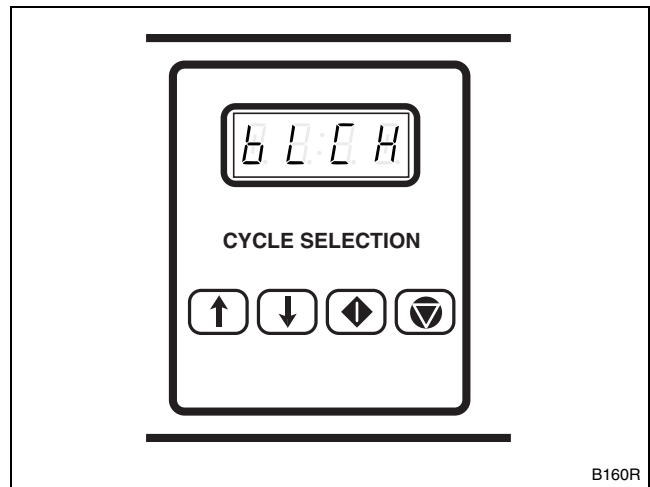

Figure 14

NOTE: To stop a cycle at any time, press the STOP key.

NOTE: To display the temperature of the water while a cycle is running, press the UP key. To display the number of the cycle in progress, press the START key.

WE-6 Computer

1. Turn on main power source (circuit breaker).
2. Use left hand to press and hold the door unlock button on top of the door box cover. Use right hand to turn door handle counterclockwise and open door. Refer to *Figure 15*.

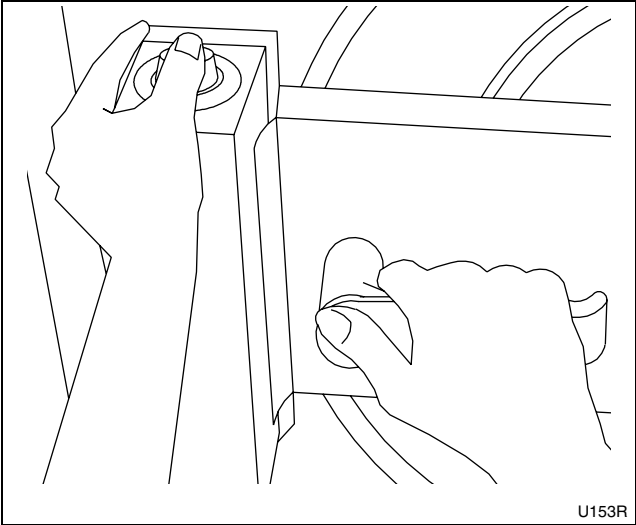

Figure 15

3. Load to capacity whenever possible. DO NOT OVERLOAD. Refer to *Figure 16*.

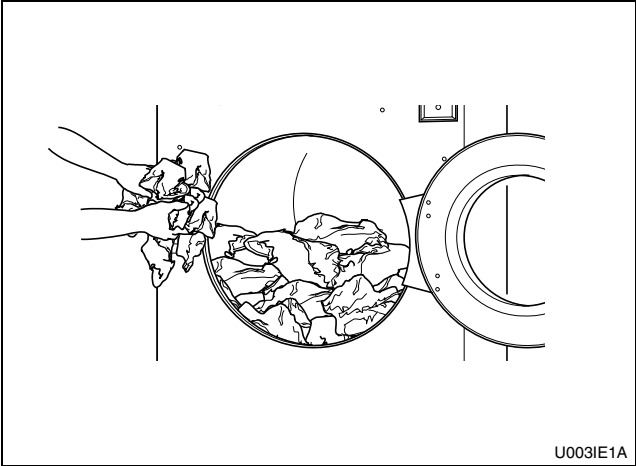

Figure 16

NOTE: For models with tilt, refer to “Loading Using Tilt Option” at the end of this section.

4. Close door and turn handle clockwise until it locks.
5. Add powder supplies to supply dispenser.

NOTE: Liquid supplies may be injected directly into the supply dispenser by an external chemical supply dispenser. Refer to Installation and Programming manuals.

6. Select wash cycle from cycle charts located in the **Programming** section of the Programming Manual.
7. Enter the cycle number, 01-39, on the keypad. Refer to *Figure 17*.

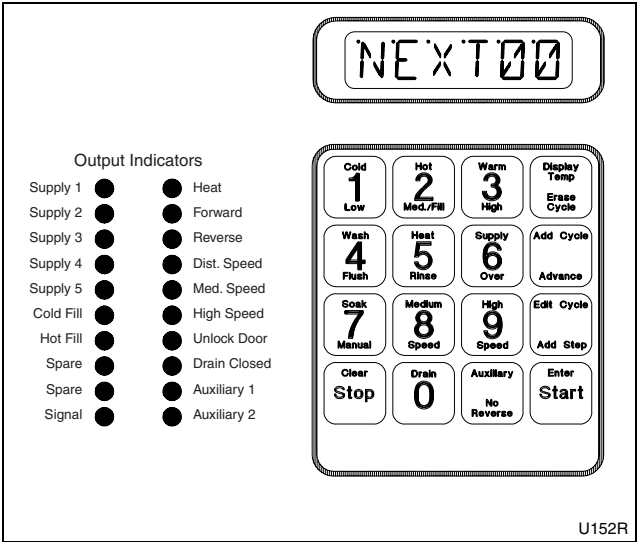

Figure 17

8. Press the START key. Refer to *Figure 17*.
9. When cycle is complete and the display reads “DONE”, open door by pressing and holding the door unlock button.
10. Unload.

Loading Using Tilt Option

Two-Way Tilt Machines

1. Open loading door and secure it to the door latch on the right side of the machine.
2. Turn the selector on the pendant switch left to the REVERSE position. Refer to *Figure 18*.

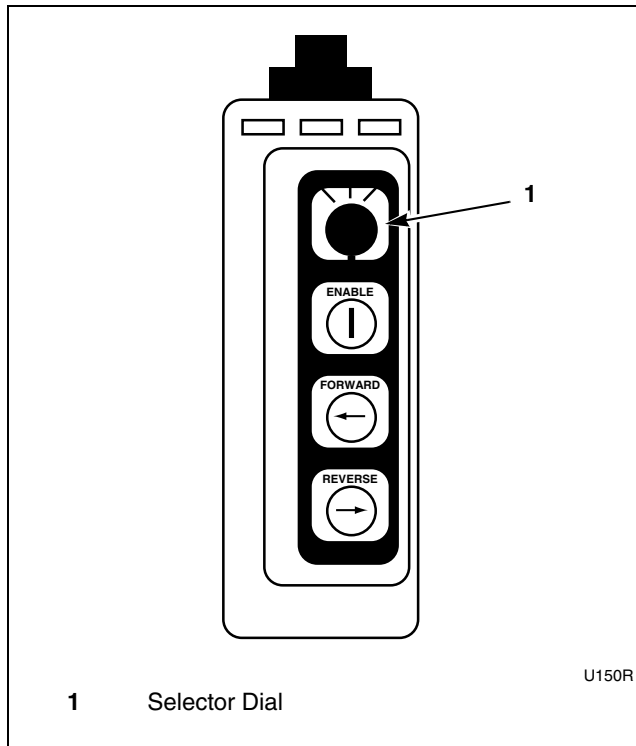

Figure 18

3. While holding down the ENABLE button, press the REVERSE button to tilt backward.
4. Load the machine.
5. Turn the selector back to the CENTER position to lower the machine.
6. Unlatch and close loading door.

Forward Tilt Machines

1. Open loading door and secure it to the door latch on the right side of the machine.
2. Check that selector on the pendant switch is in the CENTER position. If machine is in the FORWARD position, turn the selector to the CENTER position. While holding down the ENABLE button, press the REVERSE button to center the machine.
3. Load the machine.
4. Unlatch and close loading door.

Unloading Using Tilt Option

Forward and Two-Way Tilt Machines

1. Open loading door and secure it to the door latch on the right side of the machine.
2. Turn the selector on the pendant switch right to the FORWARD position. Refer to *Figure 18*.
3. While holding down the ENABLE button, press the FORWARD button to tilt forward.
4. Unload the machine.
5. Turn the selector back to the CENTER position to lower the machine.
6. Unlatch and close loading door.

Disposal of Unit

This appliance is marked according to the European directive 2002/96/EC on Waste Electrical and Electronic Equipment (WEEE).

This symbol on the product or on its packaging indicates that this product shall not be treated as household waste. Refer to *Figure 19*. Instead it shall be handed over to the applicable collection point for the recycling of electrical and electronic equipment. Ensuring this product is disposed of correctly will help prevent potential negative consequences for the environment and human health which could otherwise be caused by inappropriate waste handling of this product. The recycling of materials will help to conserve natural resources. For more detailed information about recycling of this product, please contact the local city office, household waste disposal service, or the source from which the product was purchased.

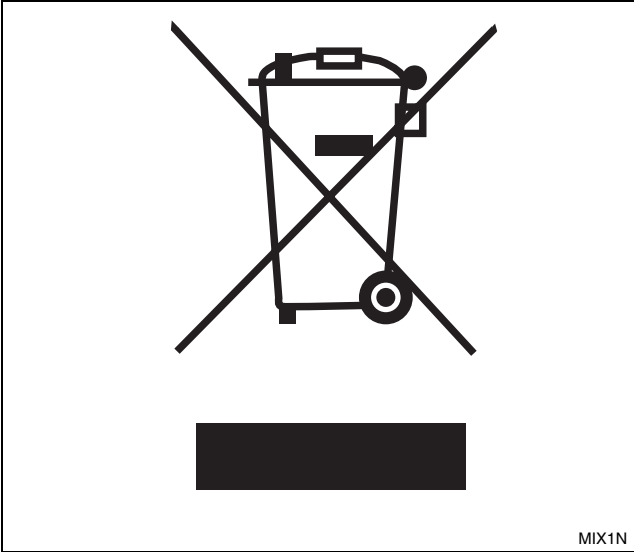

Figure 19

