

**Makita**<sup>®</sup>

**Blower**

**4014N**

**4014NV**

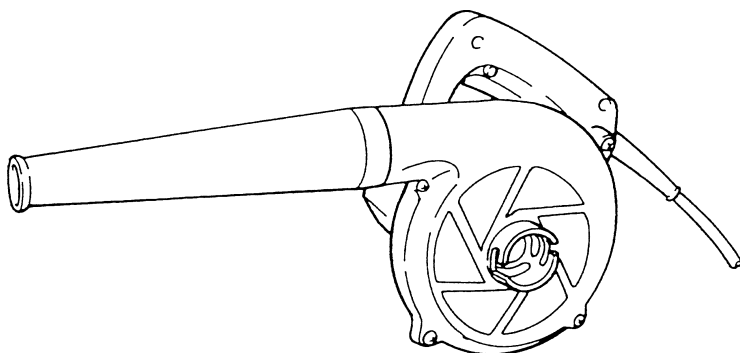

**DOUBLE  
INSULATION**

## SPECIFICATIONS

Model	4014N	4014NV
Capacities		
Air pressure (water column) .....	560 mm	0 – 560 mm
Air volume .....	2.8 m <sup>3</sup> /min.	0 – 2.8 m <sup>3</sup> /min.
No load speed (min <sup>-1</sup> ) .....	16,000	0 – 16,000
Overall length .....	430 mm	430 mm
Net weight .....	1.75 kg	1.75 kg

- Due to our continuing programme of research and development, the specifications herein are subject to change without notice.
- Note: Specifications may differ from country to country.

### Power supply

The tool should be connected only to a power supply of the same voltage as indicated on the nameplate, and can only be operated on single-phase AC supply. They are double-insulated in accordance with European Standard and can, therefore, also be used from sockets without earth wire.

### For European countries only

#### Noise and Vibration of Model 4014N

ENG005-2-V3

The typical A-weighted noise levels are  
 sound pressure level: 87 dB (A)  
 sound power level: 98 dB (A)  
 Uncertainty is 3 dB (A).  
 – Wear ear protection. –

The typical weighted root mean square acceleration value is not more than 2.5 m/s<sup>2</sup>.  
 These values have been obtained according to EN60745.

### For European countries only

#### Noise and Vibration of Model 4014NV

ENG005-2-V3

The typical A-weighted noise levels are  
 sound pressure level: 86 dB (A)  
 sound power level: 97 dB (A)  
 Uncertainty is 3 dB (A).  
 – Wear ear protection. –

The typical weighted root mean square acceleration value is not more than 2.5 m/s<sup>2</sup>.  
 These values have been obtained according to EN60745.

### Symbols

The followings show the symbols used for the tool. Be sure that you understand their meaning before use.



- Read instruction manual.



- DOUBLE INSULATION

Only for EU countries



Do not dispose of electric equipment together with household waste material!

In observance of European Directive 2002/96/EC on waste electrical and electronic equipment and its implementation in accordance with national law, electric equipment that have reached the end of their life must be collected separately and returned to an environmentally compatible recycling facility.

### EC-DECLARATION OF CONFORMITY

ENH101-4

We declare under our sole responsibility that this product is in compliance with the following standards of standardized documents,

EN60745, EN55014, EN61000  
 in accordance with Council Directives, 73/23/EEC, 89/336/EEC and 98/37/EC.

Yasuhiko Kanzaki **CE 2005**

Director

### MAKITA INTERNATIONAL EUROPE LTD.

Michigan Drive, Tongwell, Milton Keynes,  
 Bucks MK15 8JD, ENGLAND

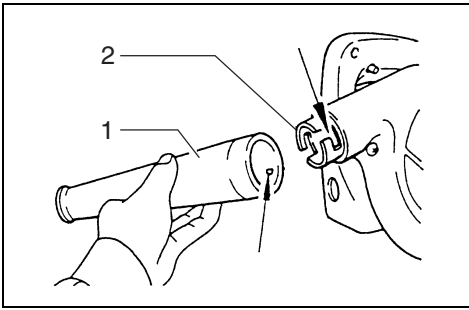

1

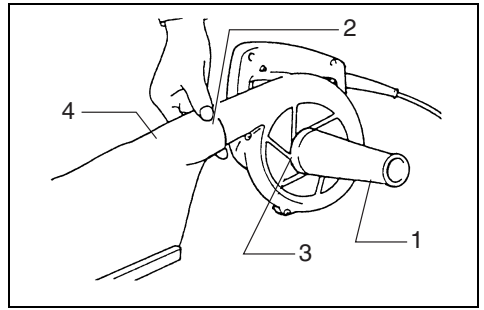

2

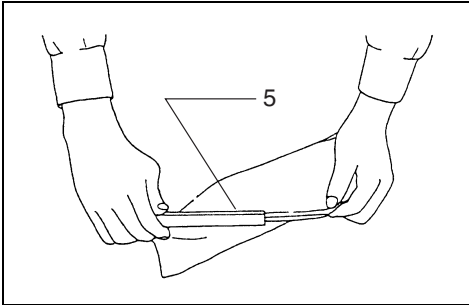

3

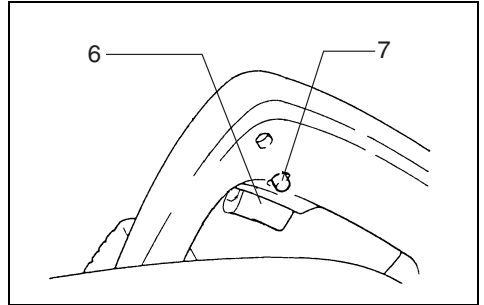

4

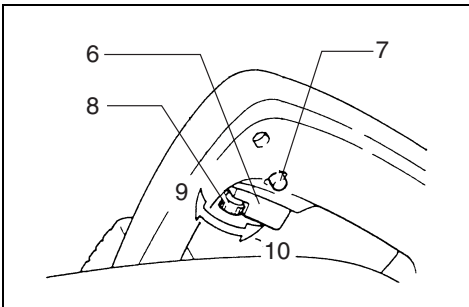

5

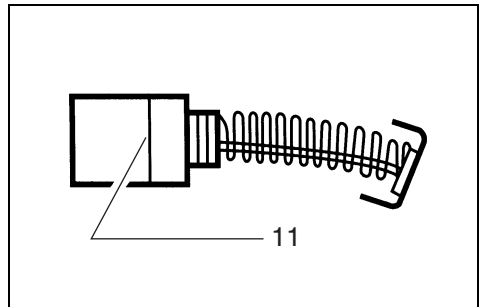

6

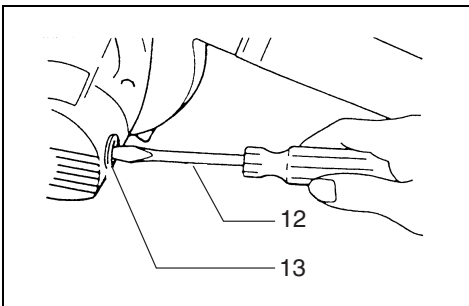

7

Explanation of general view

1 Nozzle	6 Switch trigger	11 Limit mark
2 Blower outlet	7 Lock button	12 Screwdriver
3 Suction inlet	8 Speed control screw	13 Brush holder cap
4 Dust bag	9 Lower	
5 Fastener	10 Higher	

**GENERAL SAFETY RULES**

GEA001-3

**WARNING! Read all instructions.** Failure to follow all instructions listed below may result in electric shock, fire and/or serious injury. The term "power tool" in all of the warnings listed below refers to your mains-operated (corded) power tool or battery-operated (cordless) power tool.

**SAVE THESE INSTRUCTIONS.**

**Work area safety**

1. **Keep work area clean and well lit.** Cluttered and dark areas invite accidents.
2. **Do not operate power tools in explosive atmospheres, such as in the presence of flammable liquids, gases or dust.** Power tools create sparks which may ignite the dust or fumes.
3. **Keep children and bystanders away while operating a power tool.** Distractions can cause you to lose control.

**Electrical safety**

4. **Power tool plugs must match the outlet. Never modify the plug in any way. Do not use any adapter plugs with earthed (grounded) power tools.** Unmodified plugs and matching outlets will reduce risk of electric shock.
5. **Avoid body contact with earthed or grounded surfaces such as pipes, radiators, ranges and refrigerators.** There is an increased risk of electric shock if your body is earthed or grounded.
6. **Do not expose power tools to rain or wet conditions.** Water entering a power tool will increase the risk of electric shock.
7. **Do not abuse the cord. Never use the cord for carrying, pulling or unplugging the power tool. Keep cord away from heat, oil, sharp edges or moving parts.** Damaged or entangled cords increase the risk of electric shock.
8. **When operating a power tool outdoors, use an extension cord suitable for outdoor use.** Use of a cord suitable for outdoor use reduces the risk of electric shock.

**Personal safety**

9. **Stay alert, watch what you are doing and use common sense when operating a power tool. Do not use a power tool while you are tired or under the influence of drugs, alcohol or medication.** A moment of inattention while operating power tools may result in serious personal injury.
10. **Use safety equipment. Always wear eye protection.** Safety equipment such as dust mask, non-skid safety shoes, hard hat, or hearing protection used for appropriate conditions will reduce personal injuries.

11. **Avoid accidental starting. Ensure the switch is in the off-position before plugging in.** Carrying power tools with your finger on the switch or plugging in power tools that have the switch on invites accidents.
12. **Remove any adjusting key or wrench before turning the power tool on.** A wrench or a key left attached to a rotating part of the power tool may result in personal injury.
13. **Do not overreach. Keep proper footing and balance at all times.** This enables better control of the power tool in unexpected situations.
14. **Dress properly. Do not wear loose clothing or jewellery. Keep your hair, clothing, and gloves away from moving parts.** Loose clothes, jewellery or long hair can be caught in moving parts.
15. **If devices are provided for the connection of dust extraction and collection facilities, ensure these are connected and properly used.** Use of these devices can reduce dust-related hazards.

**Power tool use and care**

16. **Do not force the power tool. Use the correct power tool for your application.** The correct power tool will do the job better and safer at the rate for which it was designed.
17. **Do not use the power tool if the switch does not turn it on and off.** Any power tool that cannot be controlled with the switch is dangerous and must be repaired.
18. **Disconnect the plug from the power source and/or the battery pack from the power tool before making any adjustments, changing accessories, or storing power tools.** Such preventive safety measures reduce the risk of starting the power tool accidentally.
19. **Store idle power tools out of the reach of children and do not allow persons unfamiliar with the power tool or these instructions to operate the power tool.** Power tools are dangerous in the hands of untrained users.
20. **Maintain power tools. Check for misalignment or binding of moving parts, breakage of parts and any other condition that may affect the power tools operation. If damaged, have the power tool repaired before use.** Many accidents are caused by poorly maintained power tools.
21. **Keep cutting tools sharp and clean.** Properly maintained cutting tools with sharp cutting edges are less likely to bind and are easier to control.
22. **Use the power tool, accessories and tool bits etc. in accordance with these instructions and in the manner intended for the particular type of power tool, taking into account the working conditions and the work to be performed.** Use of the power tool for operations different from those intended could result in a hazardous situation.

## Service

23. **Have your power tool serviced by a qualified repair person using only identical replacement parts.** This will ensure that the safety of the power tool is maintained.
24. **Follow instruction for lubricating and changing accessories.**
25. **Keep handles dry, clean and free from oil and grease.**

## ADDITIONAL SAFETY RULES

1. **Always use protective goggles, a cap and mask when using the blower.**
2. **Never point the nozzle at anyone in the vicinity when using the blower.**
3. **Always use the dust bag when collecting dust, chips and the like.**
4. **Do not collect still smoldering cigarette ashes or freshly cut metals shavings. Warning – Electric shock could occur if used on wet surfaces. Do not expose to rain. Store indoors.**
5. **Never block suction inlet and/or blower outlet. Increased motor revolution may cause dangerous fan breakage.**
6. **The tool is not intended for use by young children or infirm persons without supervision.**
7. **Young children should be supervised to ensure that they do not play with the tool.**

## SAVE THESE INSTRUCTIONS.

## OPERATING INSTRUCTIONS

### Blowing (Fig. 1)

For dust blowing, attach nozzle to blower outlet, turning clockwise to lock it in place.

### Dust suction (Fig. 2 & 3)

Note:

Dust bags are optional accessories in some countries.

For dust suction, fit nozzle onto suction inlet and dust bag onto blower outlet.

After the bag fills with dust, empty the contents of the dust bag into a dust bin by releasing the fastener.

### Switch action

CAUTION:

Before plugging in the tool, always check to see that the switch trigger actuates properly and returns to the "OFF" position when released.

### For 4014N (Fig. 4)

To start the tool, simply pull the trigger. Release the trigger to stop. For continuous operation, pull the trigger and then push in the lock button. To stop the tool from the locked position, pull the trigger fully, then release it.

### For 4014NV (Fig. 5)

To start the tool, simply pull the trigger. Tool speed is increased by increasing pressure on the trigger. Release the trigger to stop. For continuous operation, pull the trigger and then push in the lock button. To stop the tool from the locked position, pull the trigger fully, then release it.

A speed control screw is provided so that maximum tool speed can be limited (variable). Turn the speed control screw clockwise for higher speed, and counterclockwise for lower speed.

## MAINTENANCE

CAUTION:

Always be sure that the tool is switched off and unplugged before carrying out any work on the tool.

### Replacement of carbon brushes (Fig. 6 & 7)

Replace carbon brushes when they are worn down to the limit mark. Both identical carbon brushes should be replaced at the same time.

To maintain product safety and reliability, repairs, maintenance or adjustment should be carried out by a Makita Authorized Service Center.

## ACCESSORIES

CAUTION:

- These accessories or attachments are recommended for use with your Makita tool specified in this manual. The use of any other accessories or attachments might present a risk of injury to persons. Only use accessory or attachment for its stated purpose.

If you need any assistance for more details regarding these accessories, ask your local Makita service center.

- Joint
- Flexible hose
- Corner nozzle
- Straight pipe
- Nozzle assembly
- Nozzle assembly (long size)
- Dust bag assembly





**Makita Corporation**  
Anjo, Aichi, Japan

883440A221