



# Cuisine Series Heavy Duty Griddle Top Range

Item: \_\_\_\_\_  
 Quantity: \_\_\_\_\_  
 Project: \_\_\_\_\_  
 Approval: \_\_\_\_\_  
 Date: \_\_\_\_\_

Cuisine Series Heavy Duty Griddle Top Range

Models:

- |                                     |                                    |                                     |                                      |
|-------------------------------------|------------------------------------|-------------------------------------|--------------------------------------|
| <input type="checkbox"/> C2836-72   | <input type="checkbox"/> C836-72   | <input type="checkbox"/> C0836-72   | <input type="checkbox"/> C0836-72M   |
| <input type="checkbox"/> C2836-72-1 | <input type="checkbox"/> C836-72-1 | <input type="checkbox"/> C0836-72-1 | <input type="checkbox"/> C0836-72-1M |

Range with 72" Griddle Valve or Thermostat Controlled



Model C2836-72-1

Note: Range-based convection oven models can be located in the middle of a battery, banked back-to-back with other equipment, and can be positioned against a wall

Standard Features:

- Griddle top with 1" (25mm) thick steel plate.
- Full-range valve control (-72)
- Griddle control, with embedded thermostat sensor bulb Low to 500F (260C) (-72-1)
- Stainless front and sides
- Stainless steel front rail w/ position adjustable bar
- 1 1/4" NPT front gas manifold
- Can be connected individually or in a battery
- Automatic lighting – all burners
- 6" (152mm) high stainless steel stub back
- 6"(152mm) chrome steel adj. legs
- Stainless steel oven interior w/ removable porcelain bottom
- 40,000 BTU oven burner
- Chrome plated rack with four positions, 1 per oven
- Fully insulated oven interior
- 100% safety oven pilot
- Oven thermostat control - 150°-500°F (66°-260°C)

Optional Features:

- Grooved griddle - (12"W sections)

- Range base convection oven (add RC)
- Porcelain oven interior in lieu of stainless steel interior NC
- Single or double deck high shelf or back riser
- Modular unit with legs and shelf (suffix M)
- Modular unit w/o legs on Refrig. Base (change suffix M to PC)
- Stainless steel intermediate shelf for cabinet base
- Stainless steel door(s) for cabinet base units
- Stainless steel back
- Continuous plate shelf, 48-72" for battery installations
- Gas shut-off valves – 3/4", 1", 1 1/4" NPT (Specify size)
- Gas regulator: 3/4"- 1 1/4" NPT (Specify)
- Gas flex hose w/ quick disconnect 3/4", 1", 1 1/4" (Specify)
- Stainless steel legs (set of four)
- Flanged feet, set of four
- Swivel casters (4) w/ front locking
- Casters w/ polyurethane wheels – non marking
- Extra oven rack
- Rear Gas Connection; 3/4" NPT (max 250,000 BTU's)

Specifications:

U.S. Range Cuisine 72" (1829mm) wide Heavy Duty Range Series. Model \_\_\_\_\_ with total BTU/hr rating of \_\_\_\_\_ when used with natural/propane gas. Stainless steel front and sides. 6" (152mm) legs with adjustable feet.

**Ovens** - One piece oven door. Stainless steel oven interior with a heavy-duty, "keep-cool" door handle. Standard oven comes with a thermostat with a temperature range from 150° (low) to 500°F (66°-260°C). One chrome plated oven rack for standard ovens and three for convection ovens.

**Griddle Tops** - 1" (25mm) thick steel plate griddle with 3" (76mm) wide grease trough. Burners rated 30,000 BTU/hr each. One burner per 12" (305mm) section.



NOTE: Ranges supplied with casters must be installed with an approved restraining device.

Garland Commercial Industries, LLC  
 185 East South Street  
 Freeland, PA 18224  
 Phone: (570) 636-1000  
 Fax: (570) 636-3903

Garland Commercial Ranges Ltd  
 1177 Kamato Road,  
 Mississauga, Ontario  
 L4W 1X4 CANADA  
 Phone: 905-624-0260  
 Fax: 905-624-5669

Enodis UK LTD  
 Swallowfield Way,  
 Hayes, Middlesex  
 UB3 1DQ ENGLAND  
 Telephone: 081-561-0433  
 Fax: 081-848-0041

Enodis

Model #	Description	Total BTU (NAT. Gas)	Shipping	
			Cu Ft	Lb/Kg
C2836-72*	72" Manual Valve Control Griddle - w/(2)Std. Ovens	260,000	80	1500/680
C836-72*	72" Manual Valve Control Griddle - w/(1) Std. Oven & 36" Cabinet	220,000	80	1220/508
C0836-72	72" Manual Valve Control Griddle- w/ (2) 36" Cabinets	180,000	80	1350/612
C0836-72M	72" Manual Valve Control Griddle - Modular Top	180,000	40	1120/508
C2836-72-1	72" Thermostat Control Griddle - w/(2)Std. Ovens	260,000	80	1500/680
C836-72-1*	72" Thermostat Control Griddle - w/(1)Std. Oven & 36" Cabinet	220,000	80	1220/508
C0836-72-1	72" Thermostat Control Griddle- w/ (2) 36" Cabinets	180,000	80	1350/612
C0836-72-1M	72" Thermostat Control Griddle - Modular Top	180,000	40	1120/508

\* Add Suffix "RC" for Convection Oven Base

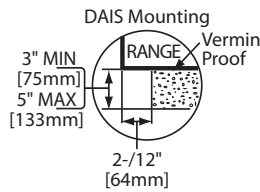

Interior Dimensions: In (mm)			
Product	Height	Width	Depth
Standard Oven	13-1/2(323)	26-1/4 (667)	29 (737)
Convection	13-1/2(323)	26-1/4 (667)	25 (635)
Cabinet Base	20-1/2 (521)	32-1/4(819)	31 (787)

Individual Burner Ratings (BTU/hr)		
Burner	NAT.	PRO.
Griddle	30,000	
Std. Oven	40,000	35,000
Conv. Oven	37,000	35,000

Gas Pressure	NAT.	PRO.
Min. Supply	7" WC	11" WC
Operating	6" WC	10" WC

Gas Manifold 1-1/4" NPT

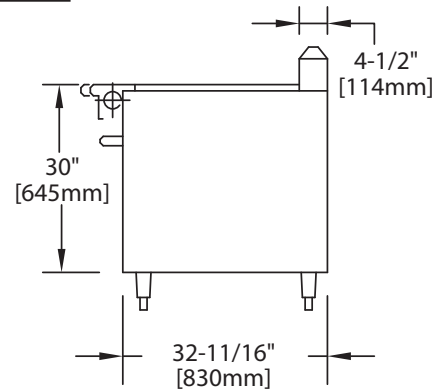
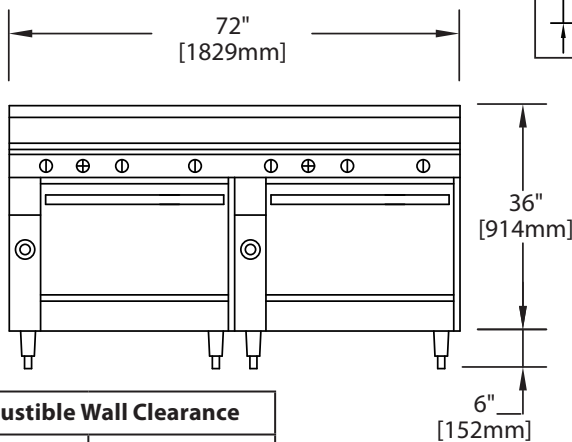
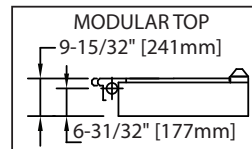
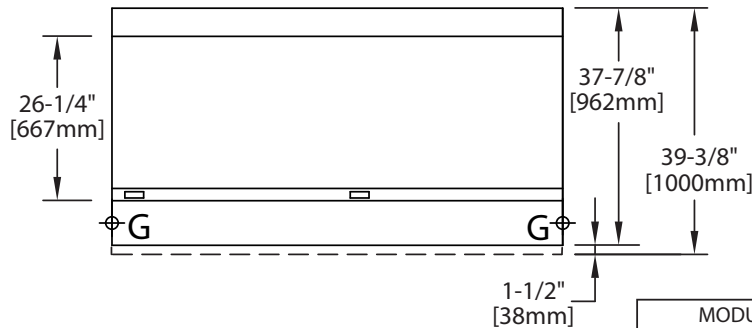

Combustible Wall Clearance	
Sides	Back
6" (152mm)	6" (152mm)

Model C2836-72 Shown

Form# C836-72 (02/26/08)