

# Installation/Care/Use Manual

## Soft Sides™ Fountains with FLEXI-GUARD®

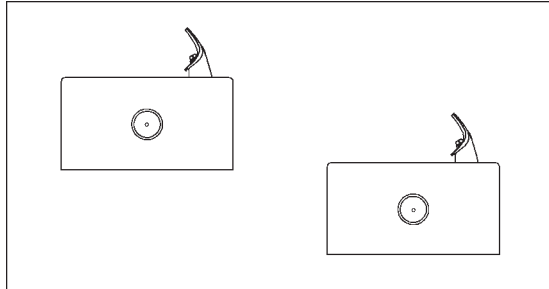

EDFP217C

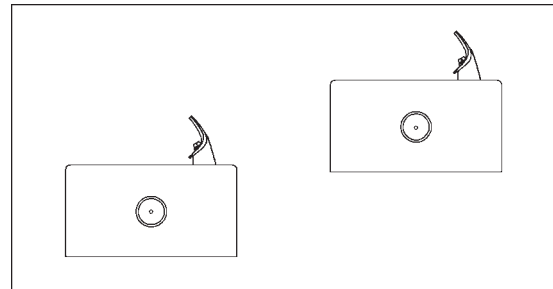

EDFP217RAC

### Installer

To assure you install this model easily and correctly, PLEASE READ THESE SIMPLE INSTRUCTIONS BEFORE STARTING THE INSTALLATION. CHECK YOUR INSTALLATION FOR COMPLIANCE WITH PLUMBING, ELECTRICAL AND OTHER APPLICABLE CODES. After installation, leave these instructions inside the fountain for future reference.

### IMPORTANT

ALL SERVICE TO BE PERFORMED BY AN AUTHORIZED SERVICE PERSON

### IMPORTANT! INSTALLER PLEASE NOTE.

THE GROUNDING OF ELECTRICAL EQUIPMENT SUCH AS TELEPHONE, COMPUTERS, ETC. TO WATER LINES IS A COMMON PROCEDURE. THIS GROUNDING MAY BE IN THE BUILDING OR MAY OCCUR AWAY FROM THE BUILDING. THIS GROUNDING CAN CAUSE ELECTRICAL FEEDBACK INTO A FOUNTAIN, CREATING AN ELECTROLYSIS WHICH CAUSES A METALLIC TASTE OR AN INCREASE IN THE METAL CONTENT OF THE WATER. THIS CONDITION IS AVOIDABLE BY USING THE PROPER MATERIALS AS INDICATED. ANY DRAIN FITTINGS PROVIDED BY THE INSTALLER SHOULD BE MADE OF PLASTIC TO ELECTRICALLY ISOLATE THE FOUNTAIN FROM THE BUILDING PLUMBING SYSTEM.

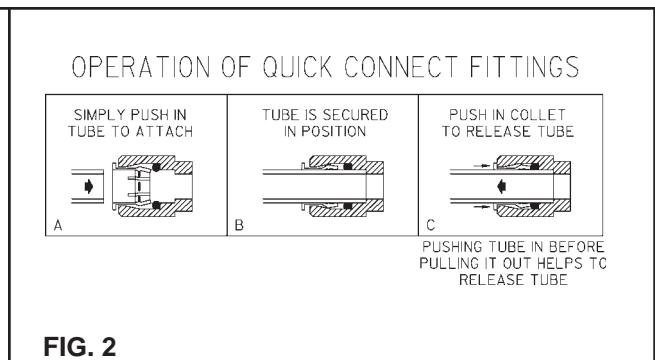
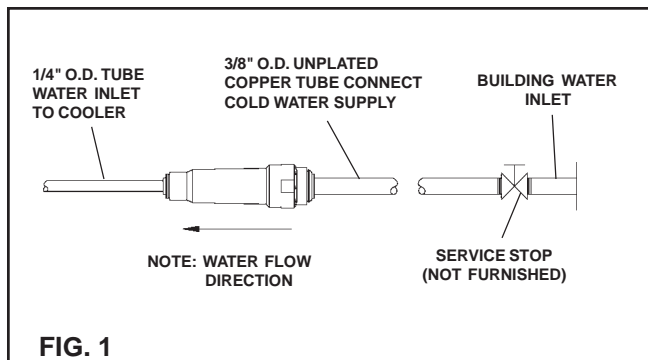

EDFP217C

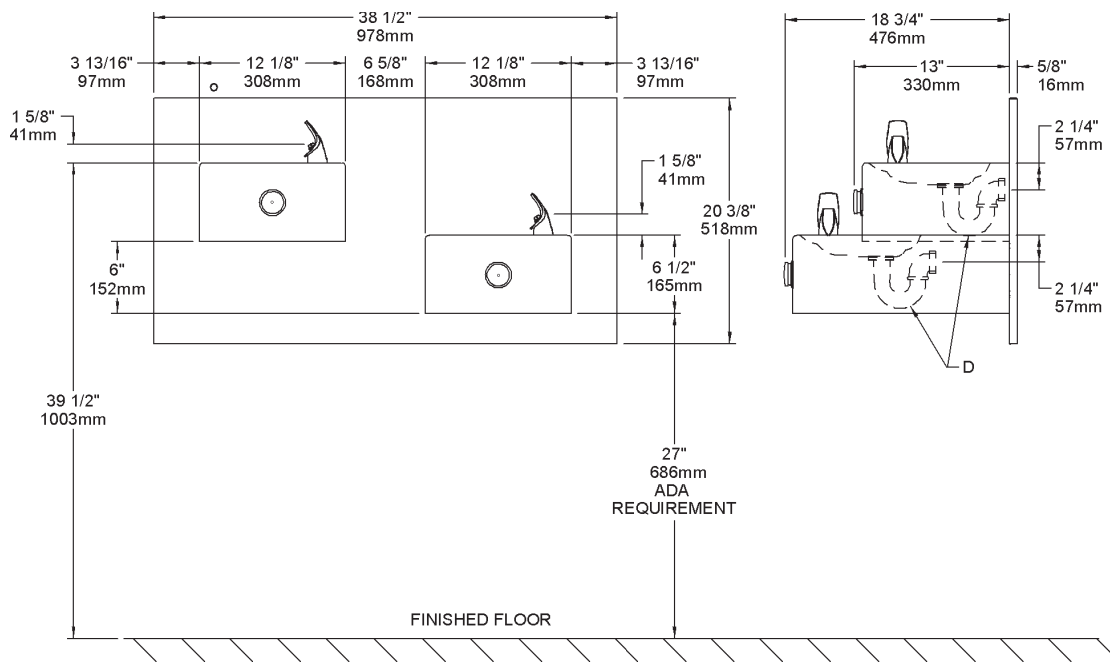
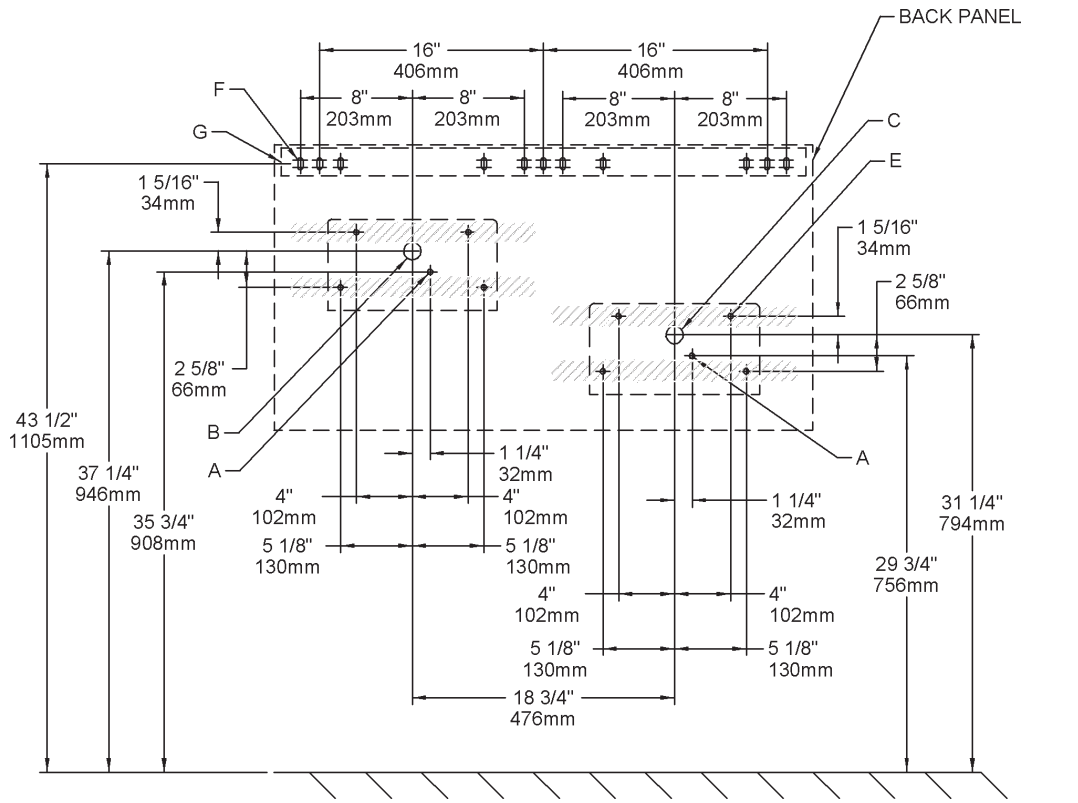

FIG. 3

LEGEND

- A = RECOMMENDED WATER SUPPLY LOCATION 3/8 O.D. UNPLATED COPPER TUBE CONNECT STUBBED 1-1/2" (38mm) FROM WALL SHUT OFF BY OTHERS
- B = RECOMMENDED LOCATION FOR WASTE OUTLET 1-1/4" O.D. DRAIN STUBBED 1-1/2" (35mm) FROM THE WALL
- C = RECOMMENDED LOCATION FOR WASTE OUTLET 1-1/4" O.D. DRAIN STUBBED 6-3/4" (168mm) FROM THE WALL

- D = 1-1/4" TRAP FURNISHED
- E = 3/8" (10mm) DIA. HOLES FOR SECURING FOUNTAIN TO WALL
- F = 3/8" (10mm) DIA. SLOTS FOR MOUNTING HANGER TO WALL
- G = WALL HANGER FURNISHED LOOSE

NOTE: REINFORCE THE WALL IN THE SHADED AREAS.

EDFP217RAC

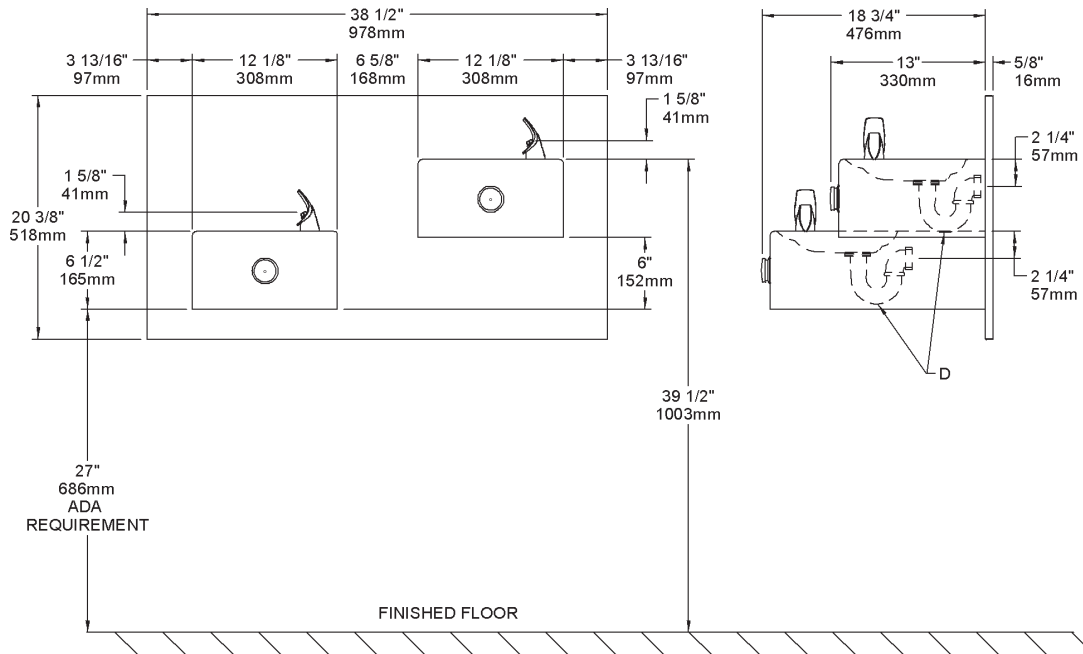
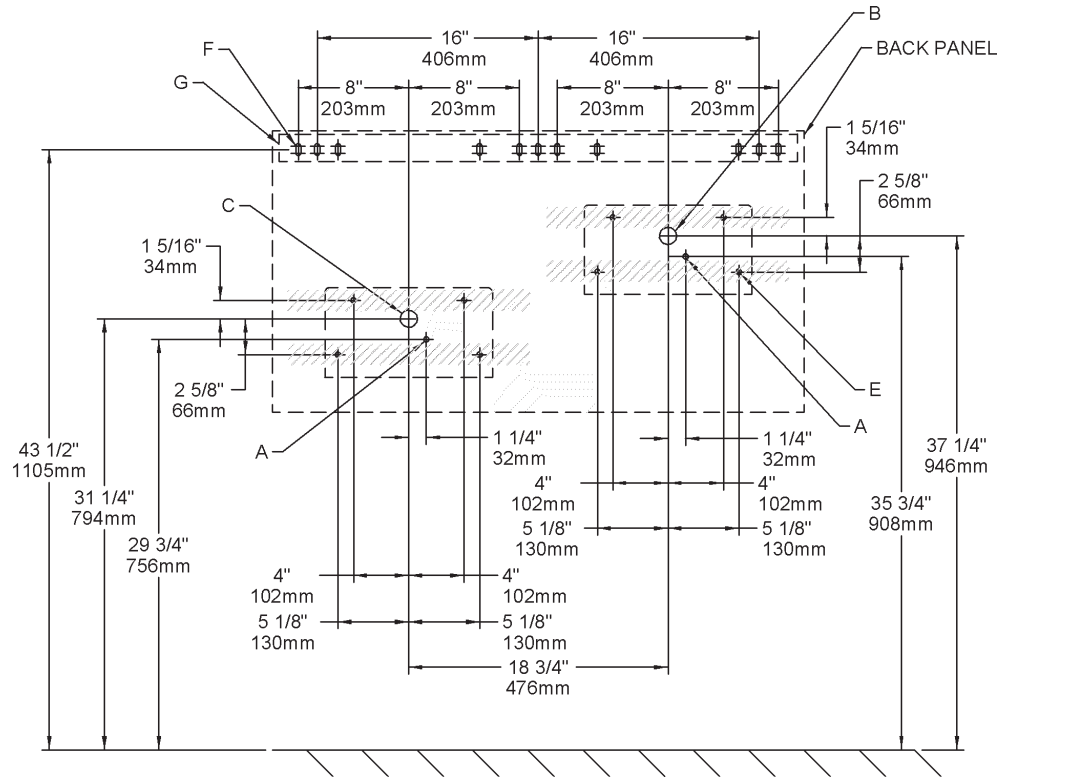

FIG. 4

LEGEND

- A = RECOMMENDED WATER SUPPLY LOCATION 3/8 O.D. UNPLATED COPPER TUBE CONNECT STUBBED 1-1/2" (38mm) FROM WALL SHUT OFF BY OTHERS
  - B = RECOMMENDED LOCATION FOR WASTE OUTLET 1-1/4" O.D. DRAIN STUBBED 1-1/2" (35mm) FROM THE WALL
  - C = RECOMMENDED LOCATION FOR WASTE OUTLET 1-1/4" O.D. DRAIN STUBBED 6-3/4" (168mm) FROM THE WALL
- NOTE: REINFORCE THE WALL IN THE SHADED AREAS.

- D = 1-1/4" TRAP FURNISHED
- E = 3/8" (10mm) DIA. HOLES FOR SECURING FOUNTAIN TO WALL
- F = 3/8" (10mm) DIA. SLOTS FOR MOUNTING HANGER TO WALL
- G = WALL HANGER FURNISHED LOOSE

EDFP217C W/MOUNTING PLATE

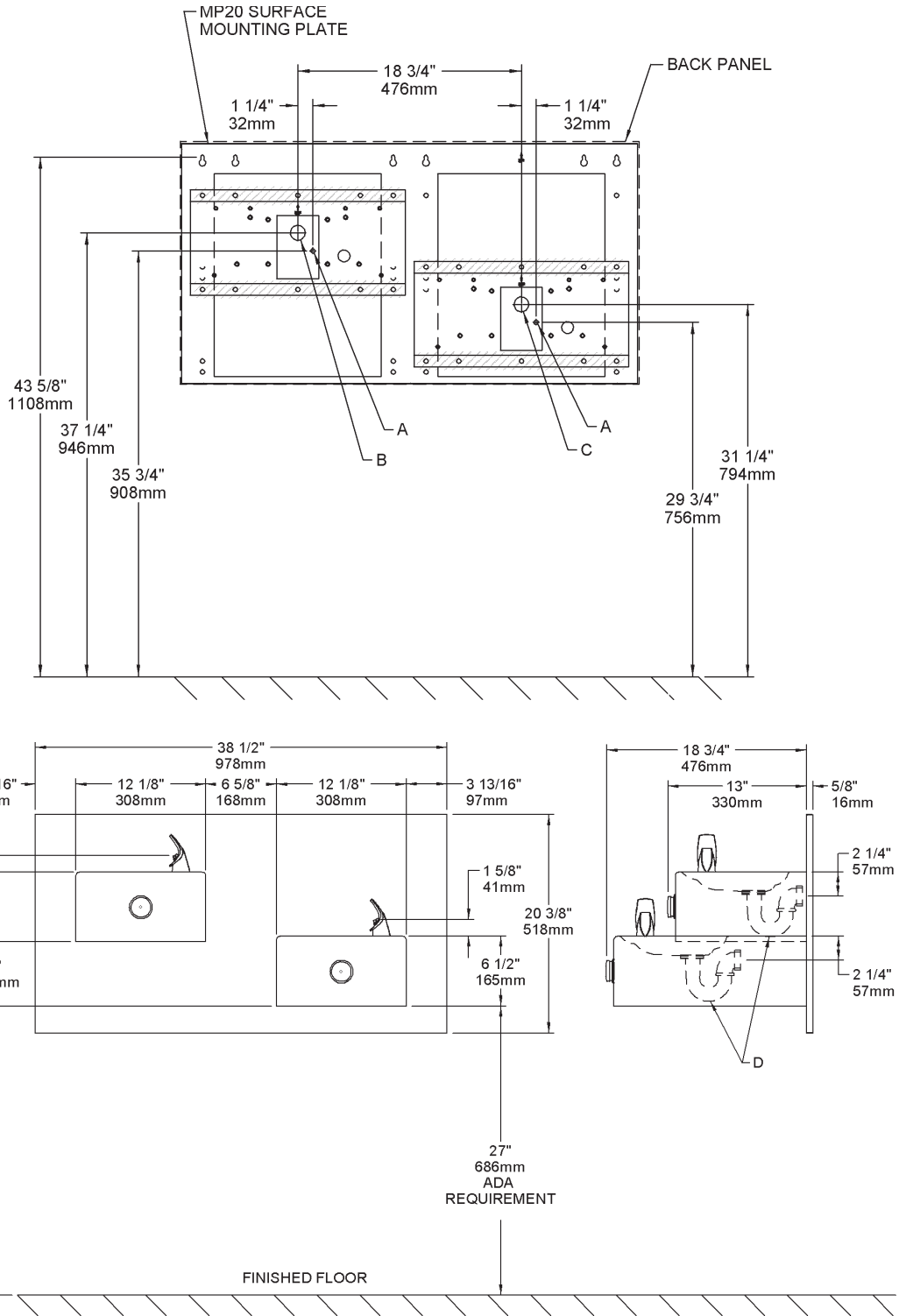

FIG. 5

LEGEND

- A = RECOMMENDED WATER SUPPLY LOCATION 3/8 O.D. UNPLATED COPPER TUBE CONNECT STUBBED 1-1/2" (38mm) FROM WALL SHUT OFF BY OTHERS
- B = RECOMMENDED LOCATION FOR WASTE OUTLET 1-1/4" O.D. DRAIN STUBBED 1-1/2" (35mm) FROM THE WALL
- C = RECOMMENDED LOCATION FOR WASTE OUTLET 1-1/4" O.D. DRAIN STUBBED 6-3/4" (168mm) FROM THE WALL
- D = 1-1/4" TRAP FURNISHED

NOTE:

REFERENCE SEPARATE INSTALLATION INSTRUCTIONS. FOR DETAILS ON MP20 SURFACE MOUNTING PLATE.

EDFP217RAC W/MOUNTING PLATE

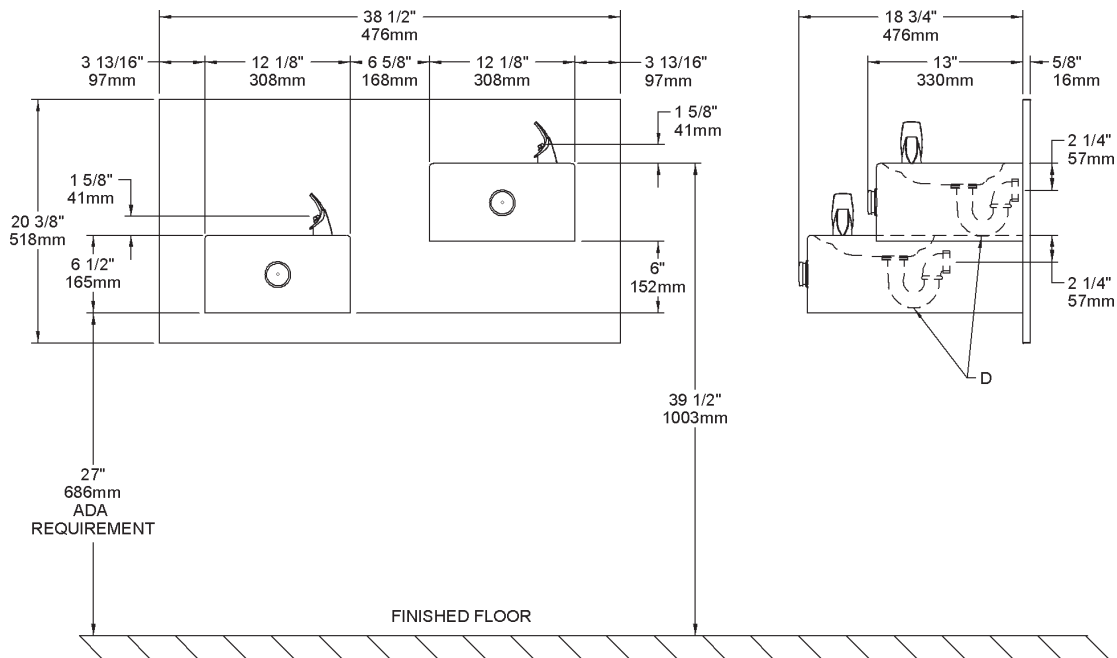
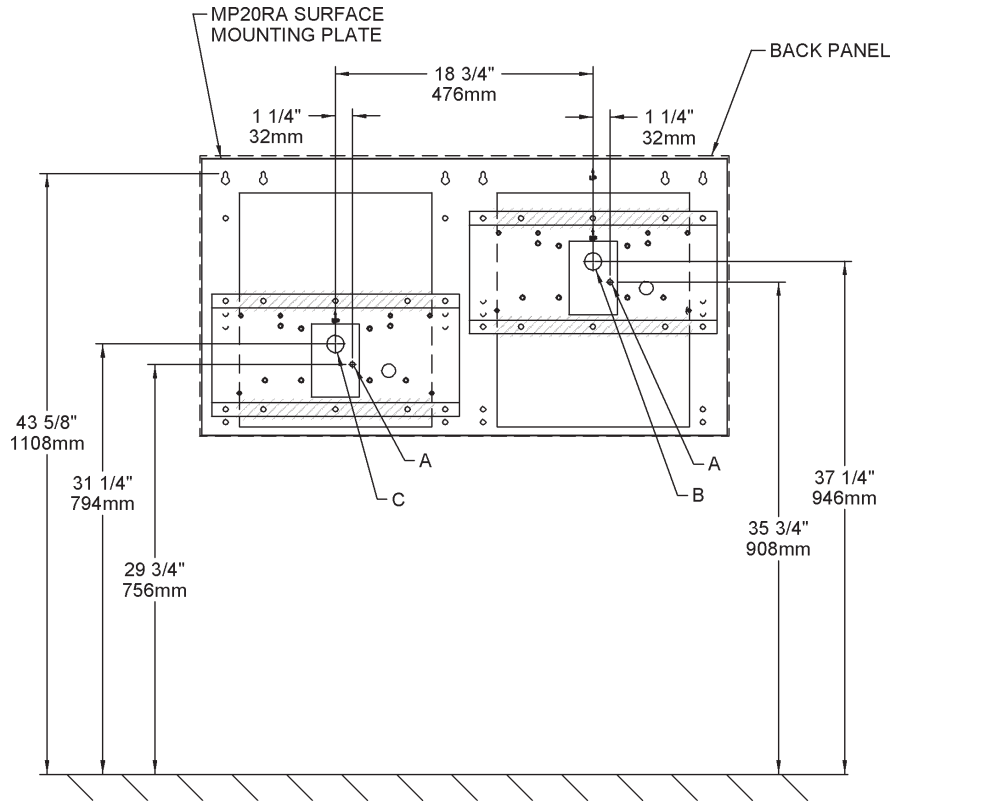

FIG.6

LEGEND

A = RECOMMENDED WATER SUPPLY LOCATION 3/8 O.D. UNPLATED COPPER TUBE CONNECT STUBBED 1-1/2" (38mm) FROM WALL SHUT OFF BY OTHERS

B = RECOMMENDED LOCATION FOR WASTE OUTLET 1-1/4" O.D. DRAIN STUBBED 1-1/2" (35mm) FROM THE WALL

C = RECOMMENDED LOCATION FOR WASTE OUTLET 1-1/4" O.D. DRAIN STUBBED 6-3/4" (168mm) FROM THE WALL

D = 1-1/4" TRAP FURNISHED

NOTE:

REFERENCE SEPARATE INSTALLATION INSTRUCTIONS. FOR DETAILS ON MP20RA SURFACE MOUNTING PLATE.

## INSTALLATION INSTRUCTIONS

1. **Wall** should already be framed for the fountain using the positioning dimensions shown in Figures 3, 4, 5, or 6. Shown dimensions pertain to installation location (framing must support up to 300 lbs. weight). These dimensions are required for compliance with ANSI Standard A117.0.
2. **Install** rough-in plumbing as shown in Figures 3, 4, 5, or 6. Waste line should extend a minimum of 2" (51mm) through the back panel. Run the supply water inlet line through the back panel. Install a service stop (not provided). Turn on supply water and flush thoroughly.
3. **Install back panel.**  
**EDFP217C:** Place the upper edge of the panel above hanger bracket.  
**EDFP217C W/MOUNTING PLATE:** Place the upper edge of the panel above mounting plate on the wall. Slide the panel down until it engages the mounting plate. Be sure back panel is firmly engaged before releasing it.
3. **Remove** bottom access panel from fountain basin and save the screws.  
**EDFP217C:** Install the fountain to the back panel and wall using (4) 5/16" x 2" long lag bolts and washers (not provided) through holes in back panel. Tighten securely.  
**EDFP217C W/WALL PLATE:** Install the fountain to the back panel using (4) 5/16" x 3/4" long screws and washers (provided) through holes in back panel. Tighten securely.
4. **Remove** elbow from end of p-trap and attach it to drain tube. Reattach elbow to p-trap and cut waste tube to required length using plumbing hardware and trap as a guide.
5. **Make** water supply connections from service stop to the 3/8" O.D. unplated copper tube coming out of the strainer. Turn on water supply and check for leaks. Newly installed water supply line should be insulated after leak check is completed. **DO NOT SOLDER TUBES INSERTED INTO THE STRAINER AS DAMAGE TO THE O-RINGS MAY RESULT.**
6. **These** products are designed to operate on 20-105 PSIG supply line pressure. If inlet pressure is above 105 PSIG, a pressure regulator must be installed in the supply line. Any damage caused by reason of connecting these products to supply line pressures lower than 20 PSIG or higher than 105 PSIG is not covered by warranty.
7. **Check** stream height from bubbler. Stream height is factory set at 35 PSI. If supply pressure varies greatly from this, adjust the screw on regulator item 10 by using a small screwdriver through the small hole in the push button item 3 (See Fig. 11). Clockwise adjustment will raise stream height and counter-clockwise will lower stream height. For best adjustment stream should hit basin approximately 6-1/2" (165mm) from bubbler.
8. **Replace** bottom access panel to fountain using the screws provided. Tighten securely.

## TROUBLE SHOOTING AND MAINTENANCE

1. **Orifice Assy:** Mineral deposits on orifice can cause water flow to spurt or not regulate. Mineral deposits may be removed from orifice with a small round file not over 1/8" diameter or a small diameter wire.  
**CAUTION:** Do not file or cut orifice materials.
2. **Stream Regulator:** If orifice is free of material deposits, regulate flow according to instruction 7 stated above.
3. **Actuation of Quick Connect Water Fittings:** Cooler is provided with lead-free connectors which utilize an o-ring water seal. To remove tubing from the fitting, relieve water pressure, push in on the gray collar while pulling on the tubing (See Figure 2). To insert tubing, push tube straight into the fitting until it reaches a positive stop, approximately 3/4".

FIG. 7

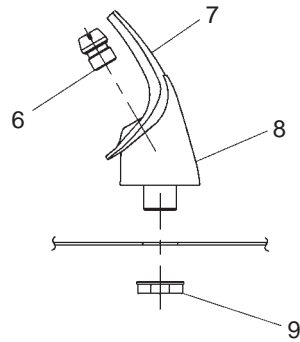
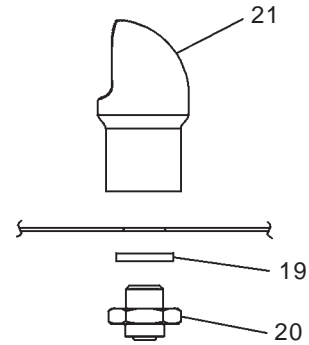

FIG. 8



NOTE: WHEN INSTALLING REPLACEMENT BUBBLER AND PEDESTAL, TIGHTEN NUT (ITEM 9 OR 20) ONLY TO HOLD PARTS SNUG IN POSITION. DO NOT OVER TIGHTEN.

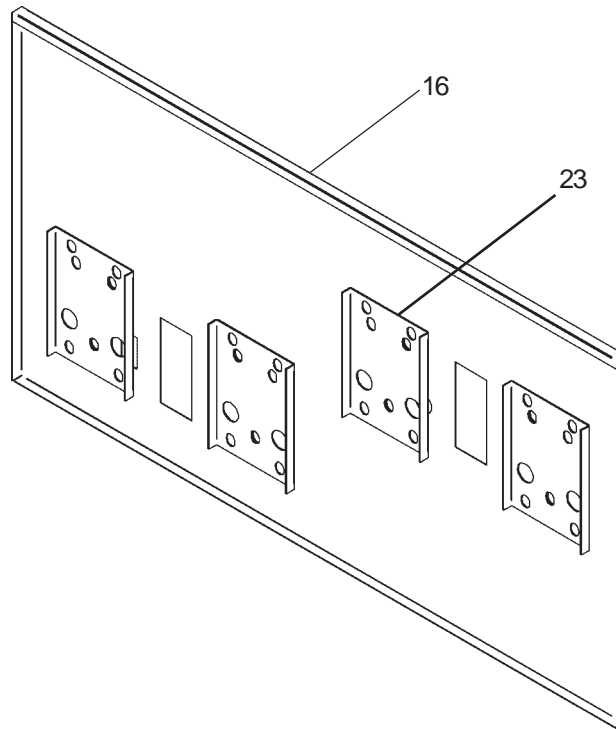

FIG. 9

**Installing back panel:** When installing back panel (item 16) without mounting plate accessory MP20 or MP20RA, attach (4) channel braces (item 23) as shown in FIG. 9. Remove the protective backing from the tape installed on the brace. Line up the corresponding holes in the brace and back panel and press firmly in place.

