

E600i TeraScale Installation Guide



Force10

Notes, Cautions, and Warnings

 **NOTE:** A NOTE indicates important information that helps you make better use of your computer.

 **CAUTION:** A CAUTION indicates potential damage to hardware or loss of data if instructions are not followed.

 **WARNING:** A WARNING indicates a potential for property damage, personal injury, or death.

Information in this publication is subject to change without notice.

© 2011 Dell Force10. All rights reserved.

Reproduction of these materials in any manner whatsoever without the written permission of Dell Inc. is strictly forbidden.

Trademarks used in this text: Dell™, the DELL logo, Dell Precision™, OptiPlex™, Latitude™, PowerEdge™, PowerVault™, PowerConnect™, OpenManage™, EqualLogic™, KACE™, FlexAddress™ and Vostro™ are trademarks of Dell Inc. Intel®, Pentium®, Xeon®, Core™ and Celeron® are registered trademarks of Intel Corporation in the U.S. and other countries. AMD® is a registered trademark and AMD Opteron™, AMD Phenom™, and AMD Sempron™ are trademarks of Advanced Micro Devices, Inc. Microsoft®, Windows®, Windows Server®, MS-DOS® and Windows Vista® are either trademarks or registered trademarks of Microsoft Corporation in the United States and/or other countries. Red Hat Enterprise Linux® and Enterprise Linux® are registered trademarks of Red Hat, Inc. in the United States and/or other countries. Novell® is a registered trademark and SUSE™ is a trademark of Novell Inc. in the United States and other countries. Oracle® is a registered trademark of Oracle Corporation and/or its affiliates. Citrix®, Xen®, XenServer® and XenMotion® are either registered trademarks or trademarks of Citrix Systems, Inc. in the United States and/or other countries. VMware®, Virtual SMP®, vMotion®, vCenter®, and vSphere® are registered trademarks or trademarks of VMWare, Inc. in the United States or other countries.

Other trademarks and trade names may be used in this publication to refer to either the entities claiming the marks and names or their products. Dell Inc. disclaims any proprietary interest in trademarks and trade names other than its own.

Contents

- 1 About This Guide
 - Information Symbols and Warnings 7
 - Related Publications 8

- 2 Site Preparation
 - Site Selection 9
 - Equipment Rack and Cabinet Requirements 9
 - Power Requirements 10
 - 2500W AC Power Requirements 10
 - DC Power Requirements 10
 - Storage Requirements 10

- 3 The E600i System
 - Operating Overview 11
 - E600i System Installation Process 13

- 4 Installing the Chassis
 - Unpacking the E600i System 15
 - Installing the Equipment Rack Shelf Bar 15
 - Standard Front Chassis Rack Mounting 16
 - Installing the Chassis into an Equipment Cabinet 17

- 5 Installing the Fan Tray
 - Fan Speed 20

- 6 Power Supply
 - AC Power Supply Units 22
 - Power Cord Requirements 23
 - Install the AC Power Supply Units 23
 - Remove the AC Power Supply 24
 - DC Power Entry Modules 25
 - Cable and Connector Requirements 25
 - Install the DC PEMs 25
 - Replace the DC PEM 26

7	Installing RPMs, Line Cards, and SFMs	
	Unpacking	29
	Line Cards and RPMs	29
	RPMs	29
	Line Cards	30
	Blank Panels	30
	Preparing and Installing the RPMs and Line Cards	30
	Installing a Second RPM	32
	RPM Label and LEDs	32
	Line Card LEDs	33
	Installing Switch Fabric Modules (SFMs)	33
	SFM Front Panel and LEDs	35
8	RPM Ports and Cables	
	RPM Ports	37
	Connecting the Console and Auxiliary Ports	37
	Cable and Adapter Pin Assignments	38
	Accessing the Console with a DB-9 Adapter	39
	Accessing the Console with a DB-25 Adapter	39
	Accessing the Auxiliary Port by Modem	40
	Accessing the 10/100 Ethernet Management Port	40
9	Powering Up	
	Preparation	41
	Supplying Power	41
	Booting to the CLI Prompt	42
	Booting from the BOOT_USER Prompt	42
10	Removing and Replacing Parts	
	Removing and Replacing the Fan Tray	43
	Removing and Replacing Power Modules	44
	Replacing 2500W AC Power Supply	44
	Replacing DC PEMs	45
	Removing and Replacing RPMs, Line Cards, or SFMs	46
	Removing and Replacing the Air Filter	48
11	Using a Flash Memory Card	
	External Flash Memory Card Overview	51
	Inserting the External Flash Memory Card	51
	Removing the External Flash Memory Card	51

Formatting an External Flash Card	52
Copying Files to the External Flash	52
Displaying Files Stored on the External Flash	52
A System Boot	
The E600i System Boot Process	55
Booting from the BOOT_USER Prompt	55
B Alarms	
AC Power Supplies and Alarms	62
SFMs and Alarms	62
C System Specifications	
Chassis Physical Design	65
Environmental	66
AC Power Supply Unit Requirements	66
DC Power Entry Module Requirement	66
SFM and RPM Power Requirements	67
Agency Compliance	67
Safety Standards and Compliance Agency Certifications	69
Electromagnetic Compatibility (EMC)	69
Product Recycling and Disposal	69
D Technical Support	
The iSupport Website	71
Accessing iSupport Services	71
Contacting the Technical Assistance Center	72
Requesting a Hardware Replacement	73

About This Guide

This guide provides site preparation recommendations, step-by-step procedures to rack mount the Dell Force10 E600i chassis, as well as instructions to install fan tray, power modules, route processor modules (RPMs), switch fabric modules (SFMs), and line cards.



This guide also includes instructions to remove and install field-replaceable parts. The E600i system is packaged with components necessary for optimal performance, including panel blanks for RPM, SFM, and line card slots, and, as required, power supply. Blanks are required in empty slots to ensure adequate system cooling and for EMI containment during operation.

After you have completed the hardware installation process and power up the system, refer to the *FTOS Configuration Guide* for preliminary software configuration information. The E600i systems runs Dell Force10 OS (FTOS™) software. The *FTOS Command Reference* provides detailed CLI information and the *FTOS Configuration Guide* includes FTOS configuration information.

Information Symbols and Warnings

[Table 1-1](#) describes symbols contained in this guide.

Table 1-1. Information Symbols

Symbol	Warning	Description
	Note	This symbol informs you of important operational information.
	Caution	This symbol informs you that improper handling and installation could result in equipment damage or loss of data.
	Warning	This symbol signals information about hardware handling that could result in injury.

 **WARNING:** The installation of this equipment shall be performed by trained and qualified personnel only. Read this guide before installing and powering up this equipment. This equipment contains two power cords. Disconnect both power cords before servicing.

 **WARNING:** This equipment contains optical transceivers, which comply with the limits of Class 1 laser radiation.



 **WARNING:** Visible and invisible laser radiation may be emitted from the aperture of the optical transceiver ports when no cable is connected. Avoid exposure to laser radiation and do not stare into open apertures.

- ⚠ **CAUTION:** Wear grounding wrist straps when handling this equipment to avoid ESD damage.
- ⚠ **CAUTION:** Earthing (AKA grounding) connection essential before connecting supply. Always make the ground connection first and disconnect it last.
- ⚠ **CAUTION:** Disposal of this equipment should be handled according to all national laws and regulations. See [Product Recycling and Disposal on page 69](#).

Related Publications

For more information about the E600i system, refer to the following documents:

- *FTOS Configuration Guide*
- *FTOS Command Reference*
- Release Notes for the E-Series

Site Preparation

This chapter describes the requirements for the room, rack, and cabinet in which you will install your system.

- [Site Selection](#)
- [Equipment Rack and Cabinet Requirements](#)
- [Power Requirements](#)
- [Storage Requirements](#)

Site Selection

Before you begin, make sure that the area where you intend to install your system meets the following requirements:

- 1 The site is in a restricted access area.
- 2 The site is a dry, clean, well-ventilated, and temperature-controlled room, away from heat sources such as hot air vents or direct sunlight.
- 3 The site is away from sources of severe electromagnetic noise.
- 4 The site is near an adequate power source. Connect the system to the appropriate branch circuit protection as defined by local electrical codes.

Equipment Rack and Cabinet Requirements

- 1 Ensure that the rack has adequate space in the front, rear, and sides after the system is installed to allow proper ventilation, access to cables, and maintenance access. Allow *at least* 18 inches in the front and 20 inches in the rear of the rack.
- 2 Ensure that the rack is bolted to the floor and/or braced to a wall or ceiling.
- 3 The minimum cabinet size is 30 inches deep and 24 inches wide.
- 4 Provide a minimum of 20 inches clearance behind the chassis to access the fan trays.
- 5 Air flows through the system from a filtered intake vent on the bottom front side of the chassis to an exhaust vent at the top rear. For proper ventilation, position the chassis in an equipment rack or cabinet so that the minimum air flow is 750 cubic feet per minute (CFM), this requires a minimum of 3 inches between the doors and the cable management system when the cabinet front doors are closed, and a minimum of 3 inches between the chassis rear and the rear of the cabinet.

Power Requirements

The E600i supports either 2500W AC power supplies (PSUs), or DC Power Entry Modules (PEMs). Do not mix and match power supplies. Your system must be powered by only AC or DC power, it cannot use both at the same time.

NOTE: Do not use different versions of power supplies. If you are replacing an AC power supply, you must replace all the PSUs in your system with the new versions. Contact Dell Force10 Technical Support if you have any question regarding the version of PSU used in your system.

2500W AC Power Requirements

The E600i 2500W AC power supply (CAT# CC-E600i-2500W-AC2) can operate at either 100 VAC or 220 VAC. If the E600i is connected to an 100 VAC power supply, it provides up to 1500W.

Parameter	Specifications
Nominal Input Voltage	100 - 120 VAC Requires a minimum of 3 Power Supplies Installed 200 - 240 VAC Requires a minimum of 2 Power Supplies Installed
Maximum AC Power Supply Input	16 A @ 100 VAC per module 12 A @ 200 VAC per module
Maximum System Power Input	4.80 KVA @ 100 VAC 4.60 KVA @ 220 VAC

DC Power Requirements

Each E-Series system requires at least one DC PEM to operate. Two units are recommended for full facility redundancy.

Parameter	Specifications
Maximum DC PEM Input Current	75 A
System	2800 W (9600 BTU/hour)
Input Voltage	-48 to -60 VDC

Storage Requirements

If you do not install all of your system components, store them in the original packaging in an environment:

- constant temperature between -40°F to 158°F (-40°C to 70°C)
- non-condensing relative humidity between 5 and 95%
- dry, away from direct sunlight, heat, and air conditioning ducts
- dust-free

The E600i System

The Dell Force10 E600i system is a carrier-class, high-capacity aggregation router. The 9-slot modular system provides 2 slots dedicated for route processor modules (RPMs) and 7 slots to accommodate line cards with Layer 2 and Layer 3 switching and routing capabilities.

Operating Overview

The E600i system requires an RPM, at least one line card, and at least four switch fabric modules (SFMs) for packet processing. The RPM is the core for routing and control operations. All traffic destined to the E600i terminates on the RPM. Routing table entries are built on the RPM and directed to the forwarding information tables on the line cards.

RPM software processes, such as Telnet, SNMP, Layer 2, and Layer 3 functions, are divided among three CPUs for redundancy and speed. Independent software images run on each CPU. Each CPU has its own memory, which isolates processes from each other, increasing reliability. Operating the E600i system with two RPMs enables automatic fail-over redundancy.

Line cards perform all data forwarding operations. Each line card has Dell Force10 proprietary ASICs; the flexible packet classification (FPC) ASIC and the Buffer and Traffic Manager (BTM) ASIC. The FPC accepts packets, feeds packets to input/output ports, handles packet classification (access lists, Layer 2 and Layer 3 lookups) and packet marking (Diffserv or 802.1p). The BTM is responsible for all queuing operations.

The internal flash memory device shipped with the RPM contains the boot ROM and runtime images. Each RPM accommodates an external flash memory card that can be used to copy and store system boot, software images, and configuration files. For information about using a flash card, refer to [Chapter 11, Using a Flash Memory Card](#).

Figure 3-1. E600i Chassis Front View with AC Power Supplies

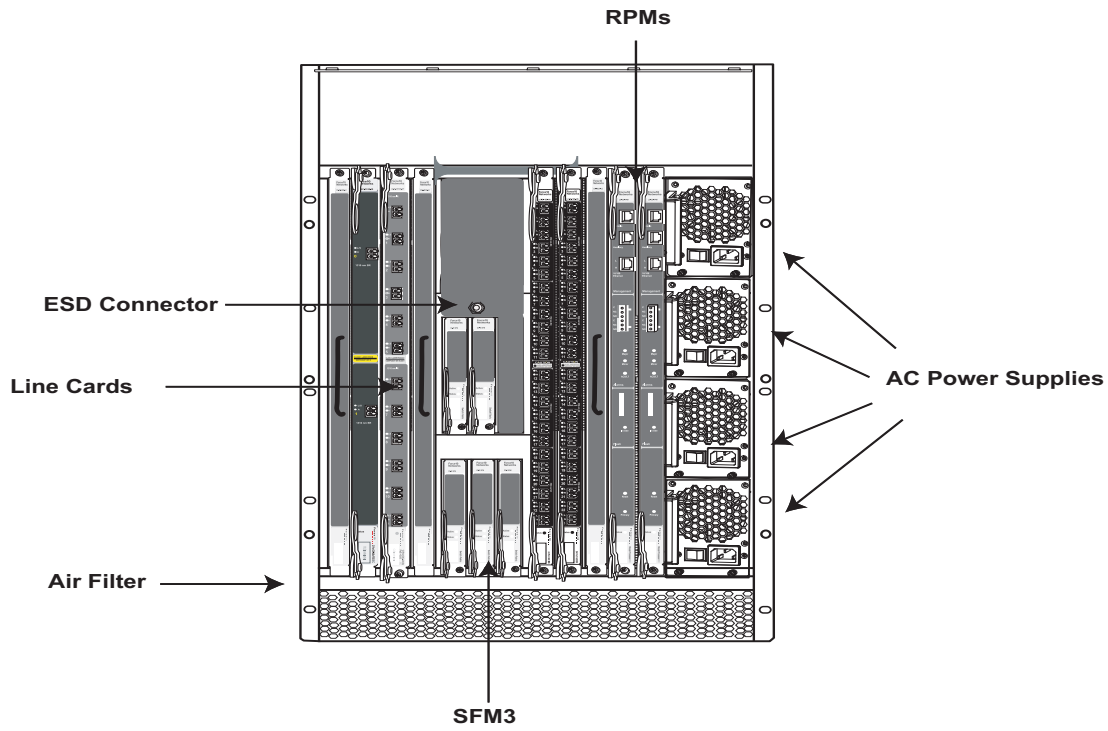

Figure 3-2. E600i Chassis Rear View

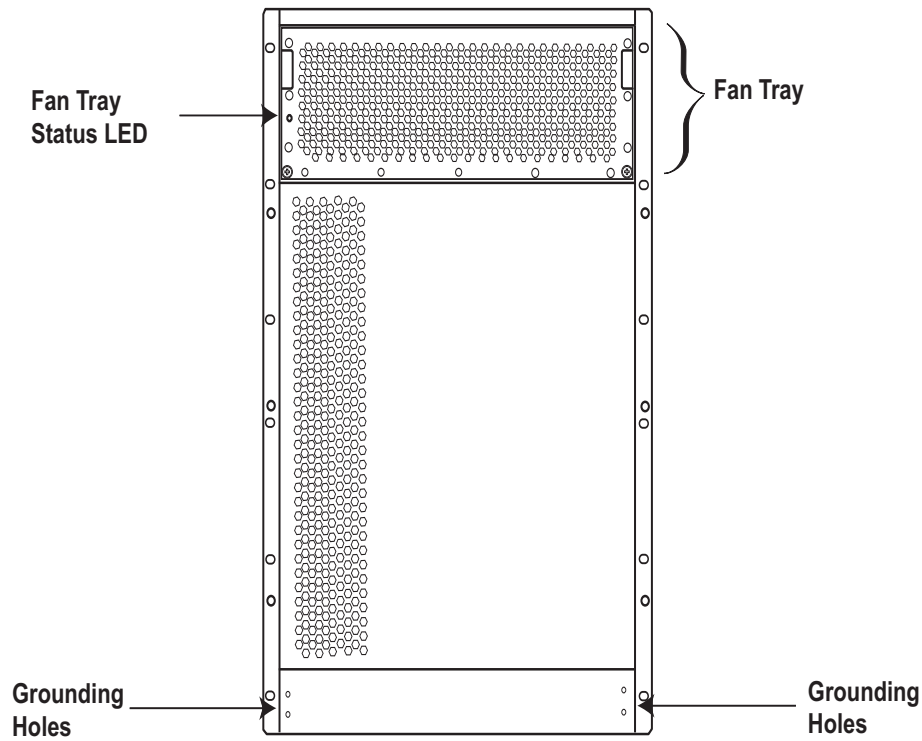

Table 3-1. E600i Hardware Component Operating Requirements Summary

Component	Minimum	Maximum	Field-Replaceable
Backplane (factory installed)	1	1	N
Air filter (factory installed)	1	1	Y
Fan tray*	1	1	Y
RPMs	1	2	Y
Line cards	1	7	Y
SFMs	4	5	Y
Power Supplies:			
2500 AC Power Supply OR	2	4	Y
DC PEMs	1	2	Y
Cable management system	0	1	Y
Cable management system cover	0	1	Y

*Fan tray is field replaceable, but must be replaced within 1 minute of removing it.

E600i System Installation Process

To install the E600i system, Dell Force10 recommends that you perform the installation procedures in the following order:

Step	Task	Section
1	Prepare the site	Site Preparation
2	Unpack the chassis and components	Unpacking the E600i System
3	Mount the chassis	Standard Front Chassis Rack Mounting Installing the Chassis into an Equipment Cabinet
4	Install components: <ul style="list-style-type: none"> • Fan tray • AC Power Supply or DC PEMs (including power cables) 	Installing the Fan Tray Power Supply
5	Install card components: <ul style="list-style-type: none"> • RPM(s) and line cards • SFMs 	Preparing and Installing the RPMs and Line Cards Installing Switch Fabric Modules (SFMs)
6	Connect network cable	RPM Ports and Cables
7	Supply power to the chassis	Powering Up

Installing the Chassis

This chapter provides instructions to rack mount your E600i system into a standard 19-inch or 23-inch equipment rack. It contains the following sections:

- [Unpacking the E600i System](#)
- [Installing the Equipment Rack Shelf Bar](#)
- [Standard Front Chassis Rack Mounting](#)
- [Installing the Chassis into an Equipment Cabinet](#)

Unpacking the E600i System

⚠ WARNING: The E600i packaging and contents weigh approximately 400 pounds. The unpacked chassis and floater pallet weigh approximately 100 pounds. Do not attempt to lift or move the chassis without the use of a hand cart, pallet jack, or forklift.

Remove all contents from the shipping packaging and move the chassis with a hand cart, pallet jack or fork lift to its rack.

⚠ CAUTION: Lift the E600i chassis from the bottom *only*. Lifting by the chassis shelves or fan tray opening will cause chassis damage. Do not remove the protective front shipping cover until you have completed the chassis installation.

⚠ WARNING: Complete the chassis installation into the rack before you install any other component (fan tray, AC power supplies or DC PEMs, line cards, RPMs, SFMs, cables).

⚠ WARNING: Electrostatic discharge (ESD) damage can occur when components are mishandled. Always wear an ESD-preventative wrist or foot-heel ground strap when handling RPMs, SFMs, or line cards. After you remove the original packaging, place RPMs, SFMs, and line cards on an antistatic surface.

Installing the Equipment Rack Shelf Bar

The rack shelf bar ([Figure 4-1](#)) enables you to easily position the chassis into the rack and provides the unit additional stability in the rack.

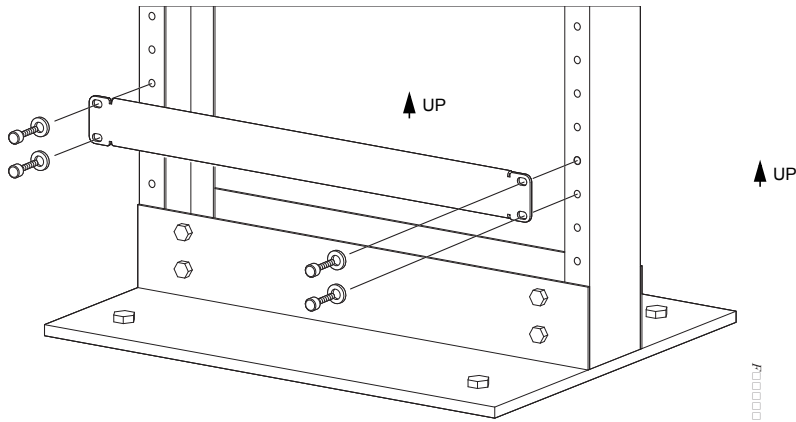
Figure 4-1. Installing the Equipment Rack Shelf Bar

To install a equipment rack shelf bar:

Step	Task
1	Determine the chassis mounting location in the equipment rack.
2	Orient the bar with the arrows pointing upward. The smooth side of the bar should face outward.
3	Attach the bar to the equipment rack brackets using the mounting screws provided by the rack manufacturer.

Standard Front Chassis Rack Mounting

Install the E600i system after you secure the equipment rack shelf bar. Load the chassis into the lower half of an empty rack to avoid a top-heavy rack. (Figure 4-2).

⚠ WARNING: Do not remove the protective front shipping cover during the initial installation process. This protective cover prevents damage to the internal framework and EMI seals.

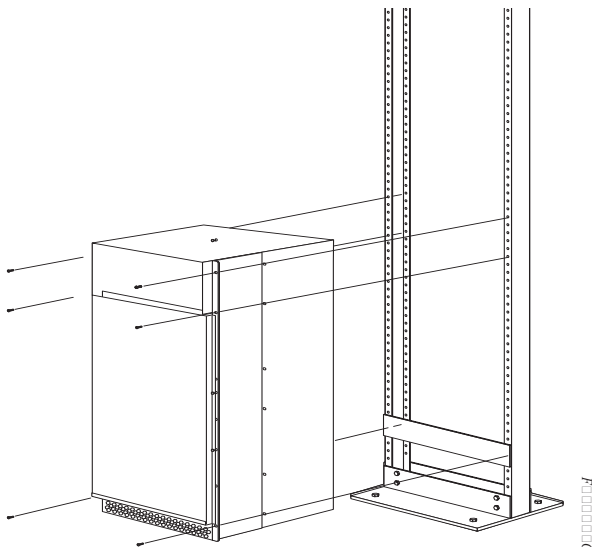
Figure 4-2. Rack Mounting the Chassis

To install the chassis into a prepared rack:

Step	Task
1	If you are center or rear mounting the chassis in a 19-inch rack, make sure that the mounting brackets are properly positioned.  NOTE: If you are mounting the chassis in a 23-inch rack, install the 23-inch adapters.
2	Using a hand cart, pallet jack, or forklift, align the rack-mount holes with the equipment rack holes, situating the chassis on top of the equipment rack shelf bar.
3	Insert rack mounting screws in the holes that are not obscured by the front shipping cover. Tighten the screws. See Figure 4-2 .
4	Loosen and remove the screws attaching the front shipping cover. Remove the cover.
5	Insert the remaining rack mounting screws and tighten to secure the chassis in the rack.

Installing the Chassis into an Equipment Cabinet

Install the E600i system after you secure the rack shelf bar. Load the chassis into the lower half of an empty rack to avoid a top-heavy rack. ([Figure 4-2](#)). Make sure the cabinet is positioned with adequate space in the front, rear, and sides of the unit for proper ventilation, access to cables, and access for maintenance. See [Rack Mounting the Chassis on page 16](#) for details.

To install the chassis into an equipment cabinet:

Step	Task
1	Install the equipment rack shelf bar.
2	Using a hand cart, pallet jack, or forklift, align the rack-mount holes with the cabinet holes.
3	Insert rack mounting screws in the holes that are not obscured by the front shipping cover. Tighten the screws.
4	Loosen and remove the screws attaching the front shipping cover. Remove the cover.
5	Insert the remaining mounting screws and tighten to secure the chassis in the cabinet.

Installing the Fan Tray

Access the fan tray from the rear of the chassis (Figure 5-1). To ensure proper temperature and airflow control, the fan tray must be installed before you supply power to the system.

⚠ WARNING: The fan tray must be installed before you supply power to the system.

⚠ WARNING: Electrostatic discharge (ESD) damage can occur when components are mishandled. Always wear an ESD-preventative wrist or foot-heel ground strap when handling chassis components. After you remove the original packaging, place chassis components on an antistatic surface.

Figure 5-1. The Fan Tray

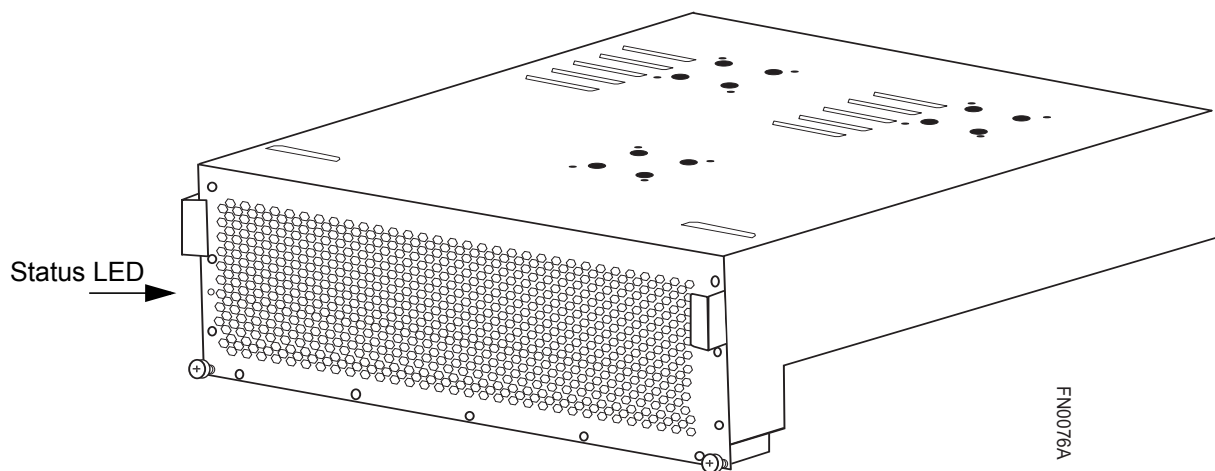

Ensure that the power switches on the remote power sources are in the OFF position. Then unpack the fan tray and follow the step below to install the fan tray.

🔧 NOTE: The fan tray weighs 20 lbs (9.072 kg).

Step	Task
1	Hold the tray with both hands and slide the connector end several inches into the fan slot, located in the rear of the chassis (Figure 5-2).
2	Push the tray until it stops and its handle end is flush with the chassis rear.
3	Secure the fan tray into place by tightening the screws. You can either tighten the screws with a Phillips screwdriver or with your fingers. Do not over tighten.

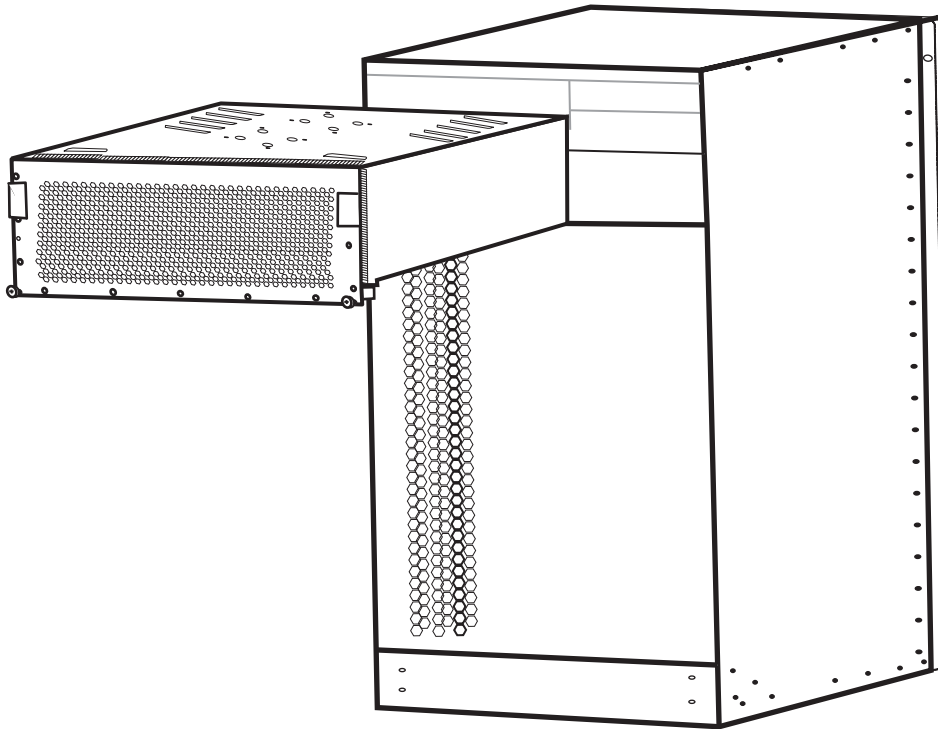
Figure 5-2. Inserting Fan Tray into Fan Slot

FN00080A

Fan Speed

Fan speed is driven by temperatures measured at the sensor in the fan tray alone. The sensor is located on the fan tray controller located in the fan tray. [Table 5-1](#) shows the sensor temperature that determines the fan speed.

Table 5-1. Fan Speed and Temperature

Degrees Celsius	Fan Speed
Less than 25C	(Low) 1800 RPM
Between 25 and 45	(Med) 2400 RPM
Above 45C	(High) 3000 RPM

Power Supply

This chapter provides instructions to install AC Power Supply Units (PSUs) and DC Power Entry Modules (PEMs):

- [AC Power Supply Units](#)
- [DC Power Entry Modules](#)

E-Series systems may contain only one type of power module—AC or DC. The E600i requires a minimum of one DC Power Entry Module or a minimum of two AC Power Supplies.

Table 6-1. Minimum Power Supply Requirements

Power Supply Input	Minimum (N)	Redundancy
220VAC	2	N + 1
110VAC	3	N + 1
DC	1	N + 1

The chassis has four power supply slots ([Figure 6-1](#)). You may install DC PEMs in slots 1 and 3 only; you may install AC power supplies in any slot.

⚠ WARNING: Class 1 laser product.

⚠ ATTENTION: Produit laser de classe 1.

⚠ WARNUNG: Laserprodukt der Klasse 1.

Figure 6-1. Power Supply Slots

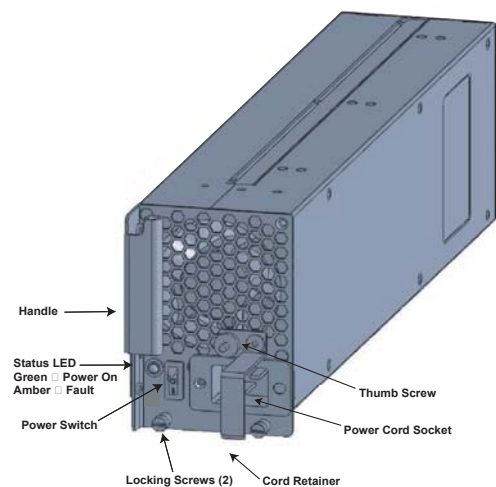

AC Power Supply Units

The 2500W AC Power Supply Unit is capable of operating at either 100 VAC or 220 VAC. If the system is connected to a 100 VAC power supply, each unit provides up to 1500W, and three power supply modules are required to power the system; four power supply units are required for power supply redundancy.

If the system is connected to a 220 VAC power supply, two power supply units are required for providing power to the system, three power supply units are required for power supply redundancy, and four power supply units are required for full facility redundancy.

Full facility redundancy requires two independent power sources (feeds) with two power supplies on each feed. Each independent power source should have a dedicated circuit breaker sized in accordance with your local electrical codes.

CAUTION: Before removing and replacing a power supply unit, determine if the E600i is in full redundancy or non-redundant mode. Operating in non-redundant mode will require a complete system power off when removing and replacing a power supply.

NOTE: Do not mix power supplies. Installing a 2500W-AC2 power supply into a chassis with 2500W-AC power supplies already installed may result in unpredictable behavior. FTOS version 8.3.1.2 and later will declare an alarm when the PSUs are mixed.

Figure 6-2. AC Power Supply Unit

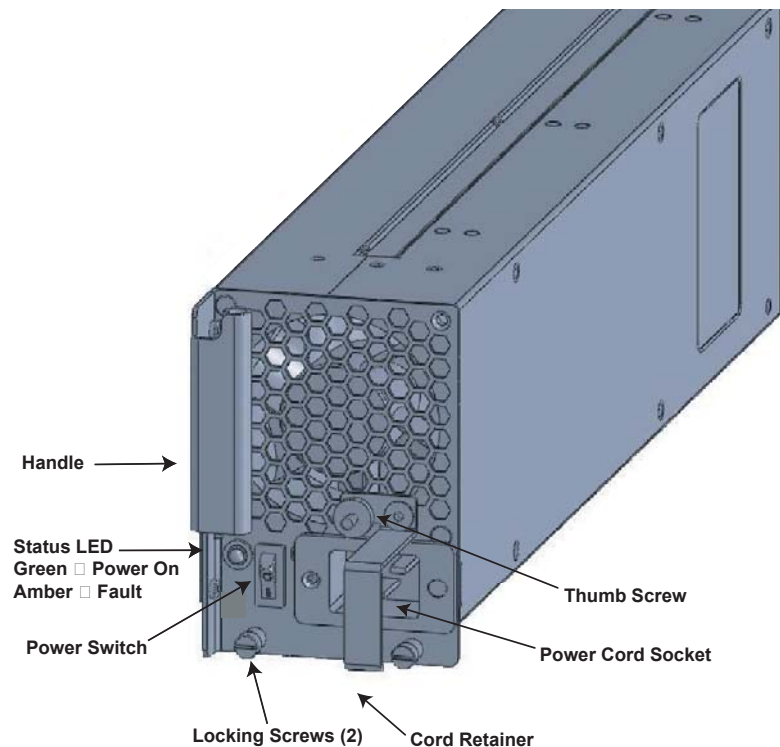

Power Cord Requirements

If using a power cord other than a Dell Force10 supplied power cord, the cord must terminate at a right angle (IEC320 C19 connector) to the power module, see [Figure 6-3](#). The power source end of the power cord must have an appropriately sized plug that complies with your local electrical codes. Conductor size must also conform to your local electrical codes.

The following are Dell Force10 supplied plug types.

- EU: CEE 7/7
- UK: CEE7/7, BS 1363
- SWZ: CEE7/7, 309
- JAP: NEMA 5-20
- JAP 220: NEMA 6-20, L6-20
- US: C14, C20, NEMA 5-20, L5-20
- US 220: NEMA 6-20, L6-20, L6-30 (30A)

Install the AC Power Supply Units

To install an AC power supply unit:

Step	Task
1	Verify that the power switch on the power supply is in the OFF position.
2	Orient the power supply handle to the left, and slide the backplane connector end into a power supply slot.
3	Secure the power supply into place by tightening the two locking screws to 5 in-lbs.
4	Plug an AC power cord into the socket on the front of the unit: a Loosen the power cord retainer thumb screw. b Rotate the retainer clockwise away from the socket and plug the power cord into the socket. c Rotate the retainer counter clockwise over the power cord, and tighten the thumb screw to secure the power cord.

Figure 6-3. Securing the AC Power Cord

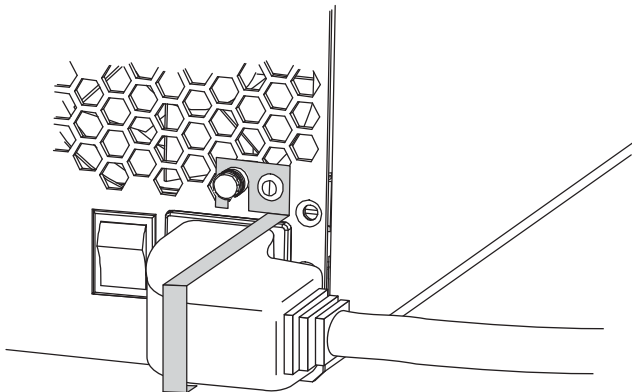

Step	Task
5	Plug the AC power cord into an AC outlet.
6	Toggle the power supply switch to the ON position, and verify that Status LED lights green.

Remove the AC Power Supply

CAUTION: This unit has more than one power supply connection; all connections must be removed to remove all power from the unit.

ATTENTION: Cette unité est équipée de plusieurs raccordements d'alimentation. Pour supprimer tout courant électrique de l'unité, tous les cordons d'alimentation doivent être débranchés.

WARNUNG: Diese Einheit verfügt über mehr als einen Stromanschluß; um Strom gänzlich von der Einheit fernzuhalten, müssen alle Stromzufuhren abgetrennt sein.

To remove an AC power supply unit:

Step	Task
1	Determine if the system is operating in power supply redundancy. If the system is operating with non-redundant power, removing a power supply powers down the system.
2	Toggle the power switch on the on the unit to the OFF position.
3	Unplug the power cord from the AC Power Supply and the AC power outlet. <ul style="list-style-type: none"> a Loosen the power cord retainer thumb screw. b Rotate the retainer clockwise away from the socket and unplug the power cord from the socket.

Figure 6-4. Removing the AC Power Cord

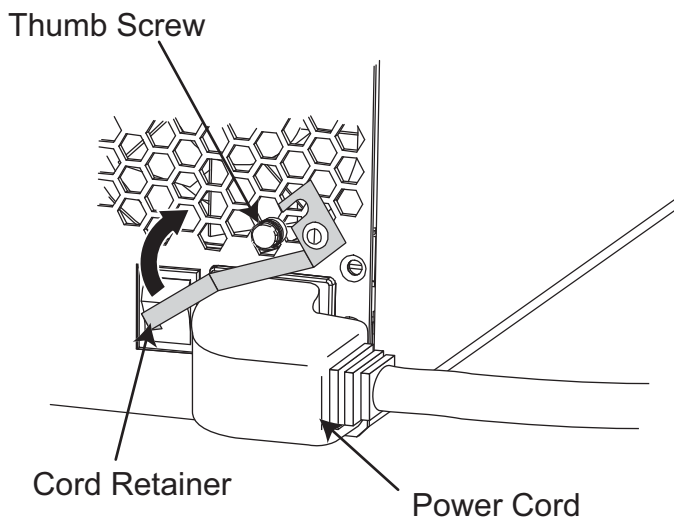

- 4 Loosen the locking screws.
- 5 Slide the power supply out of the slot.
- 6 If you are not replacing the power supply, place a power supply blank in the empty slot.

DC Power Entry Modules

The system requires a minimum of one load-sharing PEM to operate, but two are recommended for redundancy. Connect the E600 PEMs to the appropriate branch circuit protection as defined by local electrical codes.

For full redundancy, each PEM must be attached to an independent power source with a dedicated circuit breaker.

Figure 6-5. DC Power Entry Module

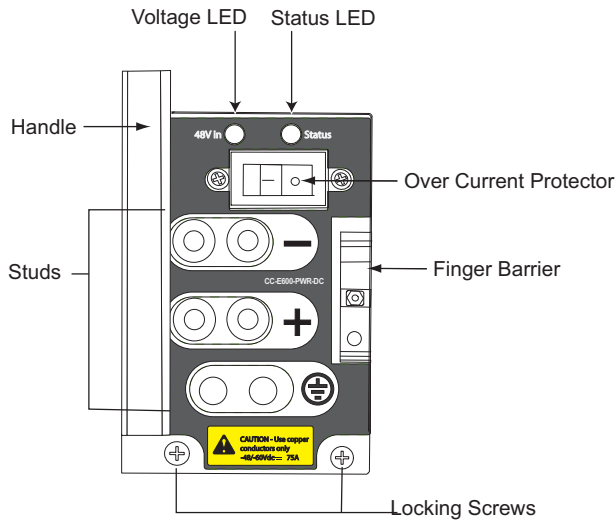

Cable and Connector Requirements

- 1 You must provide your own cables to connect to a remote power source in your equipment rack. Verify that your cables are:
 - rated for at least 80A service to allow for a fully loaded E600i system at low input voltage per your local electrical codes
 - limit voltage drop across the cable length to 0.5V or less
- 2 Before you make the cable connections, apply a coat of anti-oxidant paste to unplated metal contact surfaces.
- 3 File unplated connectors, braided straps, and bus bars to a shiny finish. It is not necessary to file and coat tinned connectors or other plated connection surfaces, such as on the PEM studs.

Install the DC PEMs

To install a DC PEM:

Step	Task
1	Make sure that the remote power source (the circuit breaker panel) is in the OFF position.
2	Make sure that the over current protector (located on the PEM front panel) is in the OFF position.

- 3 Loosen the retaining screw and remove PEM safety cover (Figure 6-6).

Figure 6-6. Removing the DC PEM Safety Cover

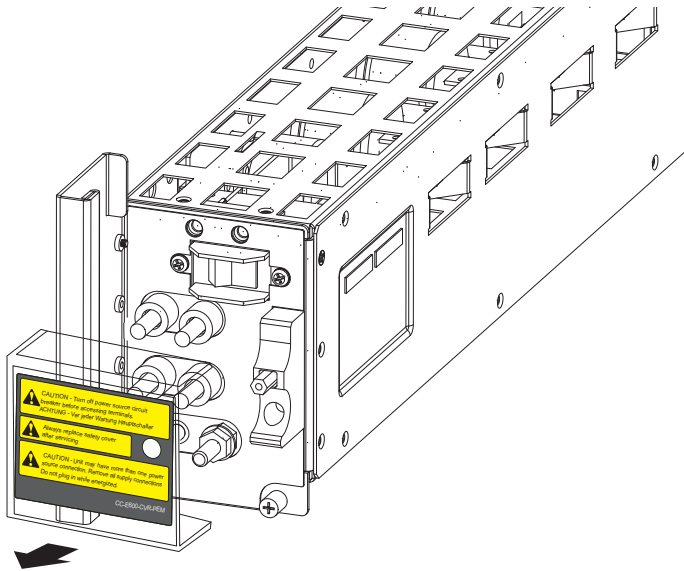

- 4 Slide the backplane connector end of the PEM into Power Supply Slot 1 or 3. Secure the PEM to the chassis by tightening the two locking screws.
- 5 Secure the chassis ground connection:
Remove one outer nut and one washer from each of the six studs. The inner nut should remain tight on the stud, at no more than 25 inch-lbs.
Locate the chassis ground connector studs on the PEM front panel (see Figure 6-5). The two bottom studs are the ground connection.
Attach the grounding cable onto the ground studs. The grounding cable must comply with your local electrical codes in size and color (typically the color is green or green with yellow stripe), and the grounding cable must be terminated only with a UL-listed 2-hole lug with 1/4-inch holes on 3/4-inch spacing (see Figure 6-7).
Replace the two washers and nuts.
With a 7/16-inch box or socket wrench, tighten the nuts to 25 in-lbs.
Connect the opposite end of the grounding cable to the nearest appropriate facility grounding post.

Figure 6-7. Cable Connector for DC Power Entry Modules

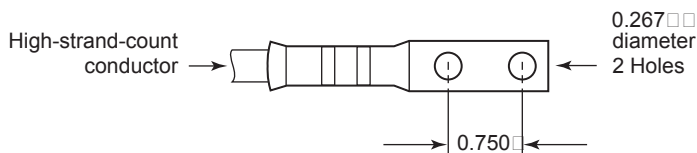

Replace the DC PEM

The PEM Status LED is unlit or amber if the unit fails. In this case, replace the entire unit. There are no field serviceable parts inside the PEM unit.

To remove a PEM:

Step	Task
1	If the system is operating with power supply redundancy, you may remove either PEM at any time. If the system is operating without power supply redundancy, power down the system before removing the PEM.
2	Power off the remote power source, and then verify that the PEM status LED and Voltage LED are unlit. To be completely sure that power is off, measure the voltage across the negative (-) and positive (+) source DC leads using a voltmeter. The measurement across the positive and negative leads must be zero (0) volts before you proceed.
3	Toggle the Over Current Protector (located on the PEM front panel) to the OFF position.
4	Loosen the PEM safety cover retaining screw, and remove the cover.
5	Disconnect power cables attached to the PEM.
6	Slide the PEM out of the slot.
7	If you are not replacing the PEM, place a power supply blank in the empty slot.

Installing RPMs, Line Cards, and SFMs

This chapter provides instructions to install cards into the E600i chassis and includes the following sections:

- [Unpacking](#)
- [Preparing and Installing the RPMs and Line Cards](#)
- [RPM Label and LEDs](#)
- [Installing Switch Fabric Modules \(SFMs\)](#)

Unpacking

 **WARNING:** Electrostatic discharge (ESD) damage can occur when components are mishandled. Always wear an ESD-preventive wrist or foot-heel ground strap when handling RPMs, SFMs, or line cards. After you remove the original packaging, place RPMs, SFMs, and line cards on an antistatic surface.

 **WARNING:** To avoid an over-temperature situation, do not supply power to your E600i system until the fan tray, RPMs, SFMs, line cards, and any required blanks are installed.

Dell Force10 recommends that you keep all components in the original packaging until you are ready to install them.

Important notes:

- It is important that you do not remove the cards from their protective bags until you are ready to install them in a chassis.
- When you are ready to install the cards, unwrap and install one card at a time, starting with the right most slot (Slot 6 for line cards, Slot R1 for RPMs, and Slot 2 or Slot 4 for SFMs) ending with the leftmost slot (Slot 0 for line cards, Slot R0 for RPMs, and Slot 0 or Slot 3 for SFMs)

Line Cards and RPMs

At a minimum, the E600i requires one RPM and one line card to operate.

 **CAUTION:** Any slot **not** filled with a line card or RPM must be filled with a blank to ensure adequate cooling and EMI containment.

RPMs

The E600i system requires the installation of at least one RPM, although two are recommended for redundancy. RPMs are designed to be installed in either the R0 or R1 slots. Do not force RPMs into line cards slots. RPMs are keyed differently than line cards to prevent improper installation.

You can hot-insert a second RPM into a running system without performance interruption or software intervention. A second RPM for redundant functionality provides uninterrupted operability if the system transitions from the active RPM to the standby RPM. The standby RPM constantly performs updates and receives the same configuration information received by the active RPM. The standby RPM also performs diagnostics on its subsystems. In the event of a switch over, the standby RPM immediately takes over and resumes the control activities that the active RPM was performing. [Installing a Second RPM](#) provides more information on the second RPM.

The RPM Major and Minor alarm LEDs are controlled by software which sets the threshold levels for triggering the different stages of alarms.

Line Cards

Your E600i configuration requires a minimum of *one* line card. Line cards are hot swappable. The line card ports provide external interface functions for connections to other systems (for example, a router or switch). Each line card has an onboard CPU for line card management which updates packet forwarding information, obtains statistical information, and performs synchronization tasks with the RPM, as well as Force10 Networks custom-built ASICs, which enable line-rate forwarding.

Line Card Port Numbering

There are seven line card slots available in the E600i chassis. A minimum of one line card is required for operation. Line cards are installed in slots 0 through 6. Ports on line cards are numbered from the top, starting from 0.

Blank Panels

 **CAUTION:** To avoid chassis over-temperature condition, install blanks for RPMs, SFMs, and line cards slots that are not in use. Always replace cards or blanks immediately.

Blank panels for RPMs, SFMs, and line cards must be installed in empty slots to control airflow. If a slot is not filled for more than five minutes, the following message appears on the console:

```
%CHMGR-2-MINORTEMP: Minor alarm: chassis temperature high (SFM temperature reaches or exceeds threshold of 65C)
```

Blank panels are shipped with the system to ensure that all chassis slots are installed with operational modules or blanks.

Preparing and Installing the RPMs and Line Cards

To install line cards and RPMs:

Step	Task
1	Remove the line card from its box and carefully remove the line card from the anti-static packaging.
2	Align the RPM with the guide and gently slide it into the slot until you feel the connectors engage with the chassis backplane.  NOTE: Hold the card by the edges. Avoid touching the printed circuit board and connector pins. Extend the top and bottom card levers before you insert the card into the slot.
3	Rotate the levers to seat the backplane connectors and line card in place.
4	Secure card and blanks in place by tightening the top and captive screws on each card.

Step	Task
5	Follow the same installation procedure for the remaining cards and slots, in the appropriate order.

NOTE: The blank panels do not have circuit boards or levers. Align the blank with the guides and gently slide toward the backplane.

Figure 7-1. Installing RPM into the E600i

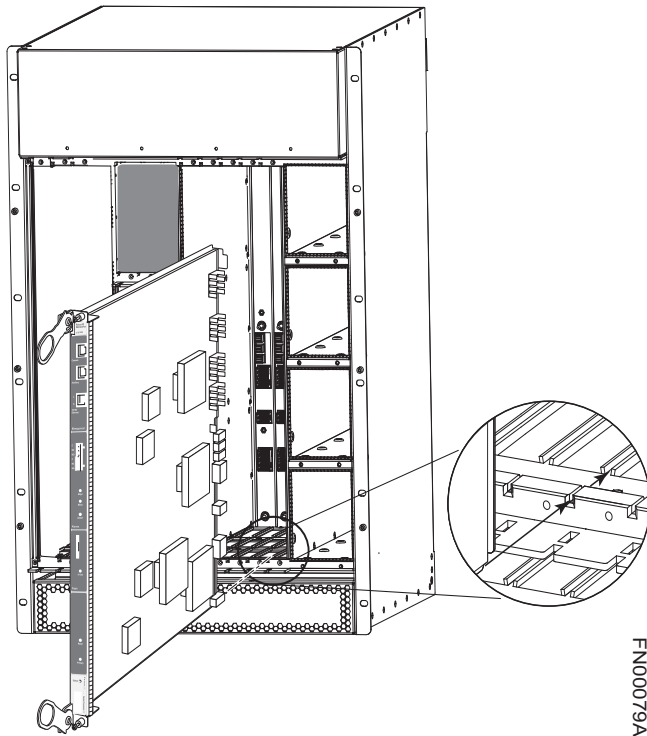

To install line cards and RPMs:

Step	Task
1	Remove the line card from its box and carefully remove the line card from the anti-static packaging.
2	Align the RPM with the guide and gently slide it into the slot until you feel the connectors engage with the chassis backplane. NOTE: Hold the card by the edges. Avoid touching the printed circuit board and connector pins. Extend the top and bottom card levers before you insert the card into the slot.
3	Rotate the levers to seat the backplane connectors and line card in place.
4	Secure card and blanks in place by tightening the top and captive screws on each card.
5	Follow the same installation procedure for the remaining cards and slots, in the appropriate order.

NOTE: The blank panels do not have circuit boards or levers. Align the blank with the guides and gently slide toward the backplane.

Installing a Second RPM

Install a second RPM either before the system is powered on or after the Primary RPM is up and stable. After the second RPM is installed, wait several seconds until the connection between the two RPMs is established before configuring any commands. Below is an example of the messages that appear:

```
%POLLMGR-2-ALT_RPM_STATE: Alternate RPM is present
%IRC-6-IRC_COMMUP: Link to peer RPM is up
%RAM-6-RAM_TASK: RPM1 is in Standby State.
```

Once the link between the two RPMs is established, copy the running configuration to the startup configuration.

RPM Label and LEDs

Table 7-1 describes the RPM LED states and the RPM front panel.

RPMs control the routing and switching functions for the entire E600i system. The E600i operates with a minimum of one RPM module. You can hot-insert a second RPM into a running system without performance interruption or software intervention. A second RPM for redundant functionality provides uninterrupted operability if the system transitions from the primary RPM to the secondary (standby) RPM. The secondary RPM constantly performs updates and receives the same information received by the primary RPM. The secondary RPM also performs diagnostics on its subsystems. In the event of a switchover, the secondary RPM immediately takes over and resumes the control activities that the primary RPM was performing.

Table 7-1. RPM LEDs

Section	Label	Description
Management	10/100 Ethernet	L: Green: link is up A: Green: activity on port
Alarms	Major	Red: a critical condition exists, such as a severe over temperature condition, a fan tray failure, an over temperature condition in a power supply, or an out-of-tolerance voltage. The RPM LEDs are controlled by software which sets the threshold levels for triggering the different stages of alarms. Unlit: no major conditions.
	Minor	Amber: a serious condition exists, such as an over temperature condition, a single fan failure, or a line card failure. The RPM LEDs are controlled by software, which sets the threshold levels for triggering the different stages of alarms. Unlit: no minor alarm conditions.
	ACO/LT	Allows you to test the operability of LEDs to verify that they are able to light. Press the ACO/LT button to temporarily illuminate the LEDs on the RPM. If you press this button when the alarm status LED is lit, the alarm relay contacts are reset until the next alarm event.

Table 7-1. RPM LEDs

Flash	In Use	Green: flash memory card is in the process of a read or write process. Do not remove the flash card when the In Use LED is lit. Unlit: not in use.
	Primary	Green: primary Unlit: secondary (or standby)
	Status	This is a bi-color LED. Green: operational Amber: fault detected Flashing green: booting Unlit: in secondary mode or power is off

Line Card LEDs

Line card LEDs are described in the documentation specific to each line card. Refer to the installation documentation that came with the card for to understand LED appearance and meaning.

Installing Switch Fabric Modules (SFMs)

A minimum of four SFMs are required in order for the E600i system to operate properly. There is an additional slot available for a redundant SFM. SFMs carry traffic between line cards or between RPMs and a line card. SFMs plug directly into the backplane, which provides high-speed access to the line cards. The switch fabric receives user data packets and redirects them to the appropriate destinations according to the routing information.

 **CAUTION:** If you are not operating your E600i system with redundancy, your SFM package will include a blank panel. Blanks do not have board components or connector pins.

You must install SFMs starting on the left (**slots 3 or 0**) moving to the right (**slots 2 or 4**).

Step	Task
1	Remove an SFM from the anti-static packaging.
2	Align the SFM with the guide and gently slide it into the slot until you feel the connectors engage with the chassis backplane.  NOTE: Hold the SFM by the edges. Avoid touching the printed circuit board and connector pins. Extend the top and bottom card levers before you insert the card into the slot.
3	Rotate the lever to seat the backplane connectors and card in place.
4	Secure each SFM in place by tightening the captive screw.
5	Continue the process for the remaining SFMs.
6	Align any blank panels with the guides and gently slide toward the backplane. Secure each blank panel by tightening the single captive screw.

Figure 7-2. Installing SFMs



Load SFMs from
right to left

FN0008

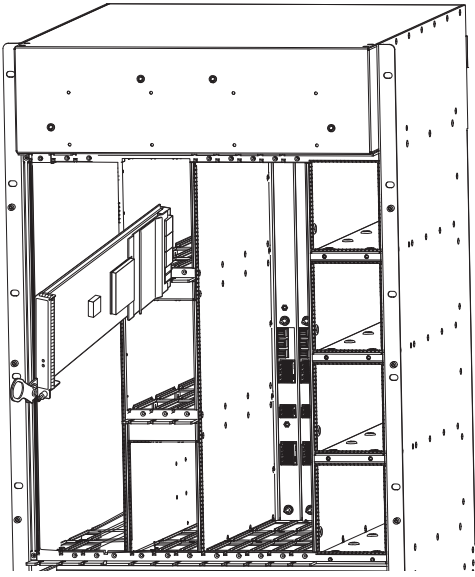
SFM Front Panel and LEDs

Table 7-2 defines the SFM front panel and LED displays.

Table 7-2. SFM Front Panel and LED Descriptions

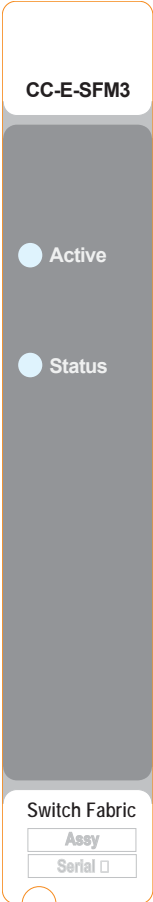
	LED	Description
 <p>The diagram shows the front panel of a CC-E-SFM3. At the top is the model number 'CC-E-SFM3'. Below it are two LEDs: 'Active' and 'Status'. At the bottom is a 'Switch Fabric' section with 'Assy' and 'Serial' labels.</p>	Active	Green: active and passing traffic Unlit: in standby mode
	Status	Flashing Green: booting Green: operational Flashing Amber: communication failure Amber: fault detected Unlit: no power

RPM Ports and Cables

This chapter describes standard RPM cables and adapter pin assignments. It contains the following sections:

- [RPM Ports](#)
- [Cable and Adapter Pin Assignments](#)
- [Accessing the 10/100 Ethernet Management Port](#)

RPM Ports

There are three ports on the RPM. They are labeled and described as:

- **Console.** A Universal Asynchronous Receiver/Transmitter (UART) port with an RJ-45 jack, is used for system configuration and monitoring. Modem connections are not supported on this port.
- **Auxiliary.** A UART port with an RJ-45 jack, allows modem access to the E600i system from a remote location.
- **10/100 Ethernet.** A 10/100 Ethernet port is the Management port, which is a channel to download images and manage the system, as well as FTP and Telnet operations. You must provide a cable terminated with an RJ-45 style connector to attach to the Ethernet receptacle.

Connecting the Console and Auxiliary Ports

 **NOTE:** Always wear an ESD-preventive wrist or foot-ground strap when handling components.

The console and auxiliary ports are asynchronous serial ports. If you connect a device to these ports, it must be capable of asynchronous transmission. Your terminal or terminal emulation mode must be set to VT100 with the following settings:

- 9600 baud rate (to avoid autobaud input, the default is set to a 9600 bps baud rate)
- No parity
- 8 data bits
- 1 stop bit
- Window Terminal Emulator option set to **NO**
- 24 lines X 80 characters
- No flow control (console port only)
- Hardware flow control (RTS/CTS) (for auxiliary port only)

Cable and Adapter Pin Assignments

Use the E600i Console port on the RPM to connect to a terminal port, PC serial port, or a terminal server to configure and monitor your system. Use the E600i Auxiliary port on the RPM to connect to a modem.

Both the Console and Auxiliary port are RJ-45 ports. [Figure 8-1](#) displays the pinouts in an RJ-45 port.

Figure 8-1. Pinouts for an RJ-45 Connector End of Adaptor

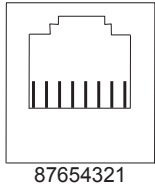

[Table 8-1](#) displays the RJ-45 console port pin assignments. [Table 8-2](#) displays the RJ-45 auxiliary port pin assignments.

Table 8-1. Console Port (RJ-45) Pin Assignments

Pin	Signal	Input/Output
1	NC (unused)	-
2	DTR	Output
3	TxD	Output
4	GND	-
5	GND	-
6	RxD	Input
7	DSR	Input
8	NC (unused)	-

Table 8-2. Auxiliary Port (RJ-45) Pin Assignments

Pin	Signal	Input/Output
1	RTS	Output
2	DTR	Output
3	TxD	Output
4	GND	-
5	GND	-
6	RxD	Input
7	DSR	Input
8	CTS	Input

Accessing the Console with a DB-9 Adapter

You can connect to the console using a RJ-45 to RJ-45 rollover cable and a RJ-45 to DB-9 female DTE adapter (labeled “TERMINAL”) to a terminal server (for example, PC). [Table 8-3](#) lists the pin assignments.

Table 8-3. Pin Assignments Between the E600i Console and a DTE Terminal Server

E600i Console Port	RJ-45 to RJ-45 Rollover Cable		RJ-45 to DB-9 Adapter	Terminal Server Device
	RJ-45 pinout	RJ-45 Pinout	DB-9 Pin	
RTS	1	8	8	CTS
DTR	2	7	6	DSR
TxD	3	6	2	RxD
GND	4	5	5	GND
GND	5	4	5	GND
RxD	6	3	3	TxD
DSR	7	2	4	DTR
CTS	8	1	7	RTS

Accessing the Console with a DB-25 Adapter

You can connect to the console using a RJ-45 to RJ-45 rollover cable and a RJ-45 to a DB-25 female DTE adapter. [Table 8-4](#) lists the pin assignments.

Table 8-4. Pin Assignments Between E600i Console and DB-25 Adapter

E600i Console Port	RJ-45 to RJ-45 Rollover Cable		RJ-45 to DB-25 Modem Adapter	Terminal Server Device
	RJ-45 Pinout	RJ-45 Pinout	DB-25 Pinout	
RTS	1	8	5	CTS
DTR	2	7	6	DSR
TxD	3	6	3	RxD
GND	4	5	7	GND
GND	5	4	7	GND
RxD	6	3	2	TxD
DSR	7	2	20	DTR
CTS	8	1		RTS

Accessing the Auxiliary Port by Modem

You can access the auxiliary port using a dial-up modem using a RJ-45 to RJ-45 rollover cable and a RJ-45 to a DB-25 male DCE adapter (labeled “MODEM”). [Table 8-5](#) lists the pin assignments.

Table 8-5. RJ-45 to DB-25 Adapter Pin (Modem) Assignments

E600i Auxiliary Port	RJ-45 to RJ-45 Rollover Cable		RJ-45 to DB-25 Modem Adapter	Modem
Signal	RJ-45 Pinout	RJ-45 Pinout	DB-45 Pinout	Signal
RTS	1	8	4	RTS
DTR	2	7	20	DTR
TxD	3	6	3	TxD
GND	4	5	7	GND
GND	5	4	7	GND
RxD	6	3	2	RxD
DSR	7	2	8	DCD
CTS	8	1	5	CTS

Accessing the 10/100 Ethernet Management Port

Configure the 10/100 Ethernet management port, labeled **10/100 Ethernet** on the primary RPM card in order to obtain network access capability, such as downloading a runtime image onto your system. You can connect this port to an Ethernet hub or Fast Ethernet port on a router.

Table 8-6. 10/100 Ethernet Management Port LEDs

Label	Description
L (Link)	Lit: Link is up. Unlit: No connection
A (Activity)	Lit: Activity on port. Unlit: No activity

Powering Up

This chapter provides instructions for powering up your E600i system once you have installed all the chassis components and made your power and network connections. It covers the following topics:

- [Preparation](#)
- [Supplying Power](#)
- [Booting to the CLI Prompt](#)

Preparation

 **NOTE:** Make sure that the switch on the remote power source is in the **OFF** position until you are ready to supply power to the chassis.

Before you supply power to your chassis, Dell Force10 recommends that you re-inspect your equipment rack and chassis.

Verify that:

- The equipment rack is properly secured and grounded.
- The chassis is bolted and secured into your equipment rack.
- Each power supply module (AC or DC) is properly installed and grounded.
- Each power supply module's switch is in the **OFF** position.
- The safety covers are installed on each DC PEM.
- Power cables connect to a compliant remote power source.
- The fan tray is installed and cannot be removed by pulling on the fan tray handles.
- All line cards, RPMs, and SFMs are properly installed and secured.
- All chassis slots are filled. Blank panels and covers are installed in all empty slots.

Supplying Power

To supply power to the E600i system:

Step	Task
1	Energize the remote power source.
2	Flip the switch on the AC power supplies or DC PEM to the ON position.
3	In a DC PEM, the Status LED should be green. In an AC Power Supply, the top Input AC and Output DC LEDs should be green. If these LEDs are not lit or the Status LED is amber on a DC PEM, check that the unit is properly installed. Verify the power source. If the LEDs remain unlit, power off all modules and replace the unit.

Step	Task
4	The fan tray LED should be green (online). Verify that air is flowing through the chassis. If the fans are not operating properly or air is not flowing through the chassis, power off the chassis at the power module. Ensure that the fan is properly installed. Verify the power source. If the fan impeller LED remains unlit, replace the fan impeller.

To turn the power off on the power modules, use one of the following methods:

- On the DC PEMs, flip the switch to the **OFF** position. Make sure the AC power supplies Status LEDs are not lit.
- On the AC Power Supplies, flip the switch to the **OFF** position and unplug the power cord from the socket on the front of the Power Supply. Make sure the Input AC and Output DC LEDs are not lit (they may flash as they power down.)

Booting to the CLI Prompt

After you supply power to the system, the following should occur:

- The fans should be operating.
- The green (online) fan tray, power module, RPM, SFM, and line card LEDs should be lit and remain lit as long as the system is receiving power and is operational.

When you supply power to the E600i system, the system performs a series of power-on self tests. RPM, line card, and SFM LEDs blink as the diagnostic programs run. No user interaction is required at this point. Observe the process on your console monitor. When the boot process is complete, the card LEDs remain online (green) and the console monitor displays the Command Line Interface (CLI) prompt.

 **NOTE:** Do not press any keys or control sequences at any time during the boot process. Doing so may cause the boot process to terminate.

Refer to the *FTOS Configuration Guide* found on the technical publications CD, for initial configuration procedures and configuration instructions.

Booting from the BOOT_USER Prompt

The initial boot operation automatically brings up the system to the runtime CLI. To interrupt the automatic boot process, issue a break key sequence (CNTL ^). The console monitor will display the default BOOT_USER # prompt. Refer to [Chapter A](#), for instructions to continue the boot process.

Removing and Replacing Parts

This chapter provides instructions for removing and replacing E600i components. It covers the following topics:

- [Removing and Replacing the Fan Tray](#)
- [Removing and Replacing Power Modules](#)
- [Removing and Replacing RPMs, Line Cards, or SFMs](#)
- [Removing and Replacing the Air Filter](#)

When a component fails, the E600i system triggers major or minor alarm LEDs (located on the RPM), sends events to the SNMP trap and show alarms table, disables or changes component Status LEDs or triggers an audible alarm. Refer to [Appendix B, Alarms, on page 61](#) for more information on alarms.

Removing and Replacing the Fan Tray

In the event of a fan tray failure, recognized by an amber LED, an SNMP trap, or major alarm event, the entire fan tray must be replaced. While you replace the fan tray, the E600i system will operate safely for up to approximately 1 minute at an ambient temperature of 95° F (35° C). If one or more fans within a fan tray fail, the system generates a minor alarm and an SNMP trap.

 **CAUTION:** Replace the fan tray within 1 minute of removing it when chassis is running.

 **WARNING:** Electrostatic discharge (ESD) damage can occur when components are mishandled. Always wear an ESD-preventative wrist or foot-heel ground strap when handling chassis components. After you remove the original packaging, place chassis components on an antistatic surface.

The fan tray is hot-swappable. To remove and replace the fan tray, you must have access to the rear of the chassis and be able to pull the fan tray completely out of the slot (at least 20 inches).

To remove and replace a fan tray:

Step	Task
1	Unpack the new fan tray from its box.  NOTE: The fan tray weighs 20 lbs (9.072 kg).
2	Loosen the captive screws on the fan tray in the E600i with a #2 Phillips screwdriver.
3	Grip both handles and pull the fan tray halfway out of the chassis.
4	Grip the sides of the fan tray and pull it from chassis.
5	Hold the new fan tray with both hands and slide the small end several inches into the fan slot.
6	Push on the rear, near the handles, until the fan tray stops and it is flush with the chassis rear.
7	Secure the fan tray into place by gently tightening the screws. You can either tighten the screws with a #2 Phillips screwdriver or with your fingers.
8	Verify that the fan tray LED is lit green (online).

Figure 10-1. Fan Tray

Removing and Replacing Power Modules

The E600i supports a minimum of one DC PEM or three 100 VAC Power Supplies (two for 200 VAC). You must have one type of power module in the chassis; you cannot install a mixture of power supply modules (see [AC Power Supply Units on page 22](#)). Blanks must be installed in any empty power supply slot.

Replacing 2500W AC Power Supply

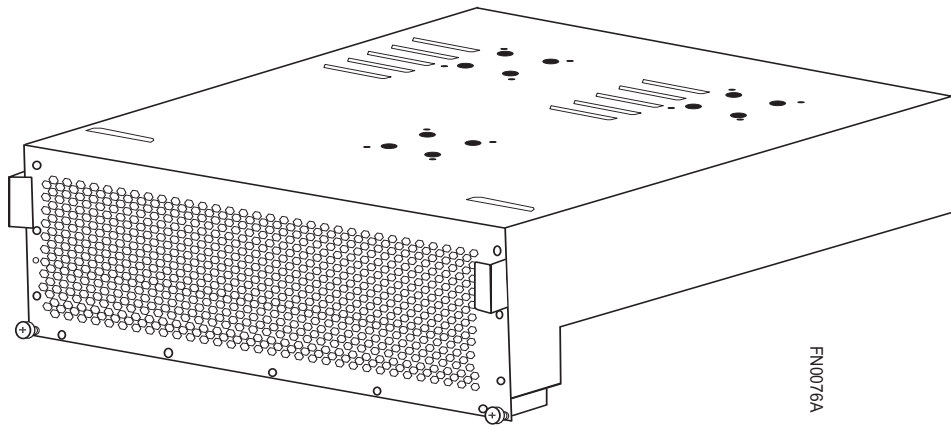
The E600i 2500W AC Power Supply (CAT# CC-E600-2500W-AC2) is capable of operating at either 110 VAC or 220 VAC.

CAUTION: Before removing and replacing a power supply module, determine if the E600i is in power supply redundancy or non-redundant power. Operating in non-redundant power will require a complete system power off when removing or replacing a power supply.

Follow the steps below to remove and replace a 2500W AC Power Supply.

Step	Task
1	Flip the switch on the power supply to the OFF position.
2	Unplug the power cord from the AC Power Supply and the AC power outlet. The power supply cord is the main disconnect device. Loosen the power cord retainer thumb screw. Rotate the retainer clockwise away from the power cord and remove the power cord from the socket.

Figure 10-2. Removing the Power Cord

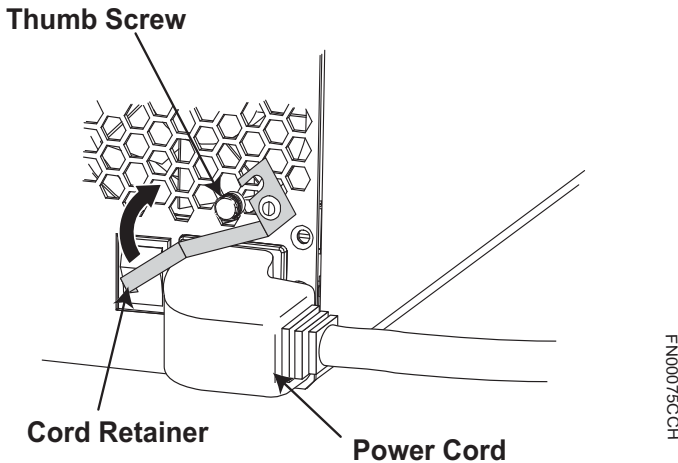

- 3 Loosen the locking screws, using a #2 Phillips screwdriver.
- 4 Slide the power supply out of the slot.
- 5 If you are replacing the power supply, see [Install the AC Power Supply Units](#). If you are not replacing the power supply, replace the empty slot with a power supply blank cover.

Replacing DC PEMs

If you are operating your E600i chassis with redundant DC PEMs, you can install, remove, or replace a DC PEM without affecting system operation. If you are operating your E600i system with only one DC PEM (the minimum), you must completely power off the system.

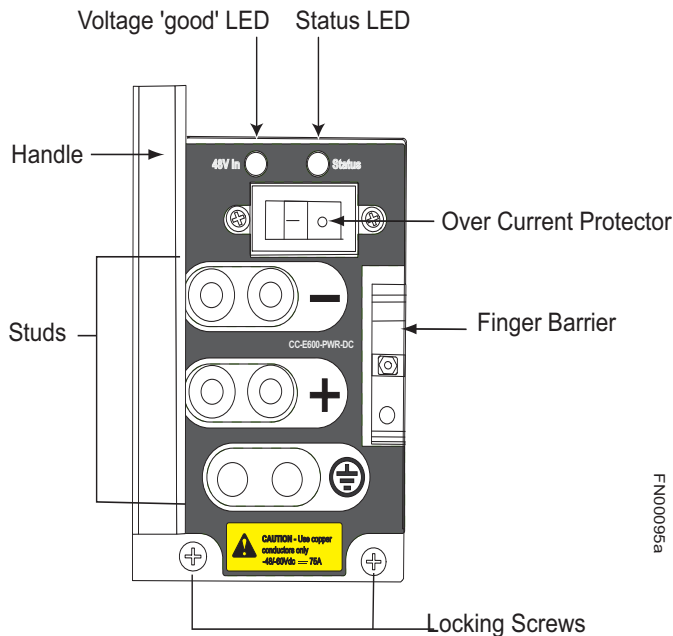
Figure 10-3. DC PEM Label

NOTE: If there is a PEM failure (the PEM status LED is not lit or amber, major alarm LED is lit, and audible alarm sounds), the entire PEM must be replaced. There are no field serviceable parts inside the PEM unit.

WARNING: Do not remove the PEM safety cover until the power supplied by the remote power source is **OFF**.

WARNING: To be completely sure that power has been turned off, use a voltmeter to measure the voltage across the negative (-) and positive (+) source DC leads. The measurement across the positive and negative leads should be zero (0) volts before you proceed with the replacement.

To remove a PEM:

Step	Task
1	Ensure that the remote power source is in the OFF position and that the PEM status LED and Voltage LED are off.
2	Switch the Over Current Protector (located on the PEM front panel) to the OFF position.
3	Loosen the retaining screw and remove PEM safety cover.
4	Disconnect power cables attached to the PEM.
5	Slide the PEM out of the slot.
6	If you are replacing a PEM, go to Power Supply . If you are not replacing the PEM, replace the empty slot with a PEM blank.

Removing and Replacing RPMs, Line Cards, or SFMs

WARNING: Do not remove a panel blank unless you are ready to install a line card, RPM, or SFM into that slot. If you remove a card, immediately replace the empty slot with a panel blank. Blanks are required to control airflow and electromagnetic interference.

WARNING: Electrostatic discharge (ESD) damage can occur when components are mishandled. Always wear an ESD-preventive wrist or foot-heel ground strap when handling RPMs, SFMs, or line cards. After you remove the original packaging, place RPMs, SFMs, and line cards on an antistatic surface.

 **NOTE:** If you operate your E600i without redundant RPMs, the system enters a software-defined power-down state when you remove the only RPM for replacement.

 **NOTE:** Your E600i system will not function with fewer than four SFMs.

You can add, replace, or remove modules without interrupting the system power or system operations. RPMs, line cards, and SFMs are hot-swappable. The E600i system generates major alarm events for module failures and high temperatures (over 70°C for RPMs and over 80°C for line cards) depending on the module and whether or not it is redundant. Minor alarms are generated for component temperatures over 65°C for RPMs and 75°C for line cards. SNMP traps are sent for both alarm types. Refer to [Chapter B](#), for more details.

To remove and replace RPMs and line cards:

Step	Task
1	Unplug the network interface cables connected to the line card or RPM.
2	Loosen the captive screws and pull the ejector levers simultaneously toward you to disengage the backplane connections.
3	Slide the card out of the slot and store the card in the original anti-static packaging.
4	If you are immediately installing a replacement card, align the new card with the guide and gently slide the card into the slot until you feel the connectors engage with the chassis backplane. If you are not planning to install a new card immediately, install a blank panel.
5	If you are installing a line card, follow these procedures: <ul style="list-style-type: none">• If you are hot swapping (replacing the line card with the same card type), no additional configuration is required.• If you are installing a different line card type, enter following configuration command: linecard <i>number card-type</i> where <i>number</i> is a slot number from 0 to 6, and <i>card-type</i> is the five-character code for the card type. Refer to the <i>FTOS Command Line Interface Reference</i> for more information.• If you are replacing the line card with a blank panel, delete the line card information from the configuration by entering: no linecard <i>number</i>
6	If you are <i>not</i> operating your system with redundant cards (with only one line card, one RPM, and four SFMs) you must power off your system until the cards are replaced.

To remove and install an SFM:

Step	Task
1	Loosen the captive screw and pull the ejector lever towards you to disengage the backplane connections.
2	Slide the card out of the slot and store in the original anti-static packaging. System messages appear on the console, including the following: %TSM-6-SFM_REMOVE: Removed SFM Wait 5 to 10 seconds to install a new SFM or reinsert an SFM. *
3	Remove the new SFM from the antistatic packaging.

Step	Task (<i>continued</i>)
4	Align the new SFM with the guide and gently slide the card into the slot until you feel the connectors engage with the chassis backplane.  NOTE: Hold the SFM by the edges. Avoid touching the printed circuit board and connector pins. Extend the card lever before you insert the card into the slot.
5	Rotate the lever to seat the backplane connectors and SFM in place.
6	Secure the SFM in place using the provided screw.
7	If you are not operating your E600i system with redundancy, replace the empty slot with a filler panel blank. Blanks do not have board components or connector pins. Align the blank with the guides and gently slide toward the backplane. Rotate the lever to secure the blank in place.

* If you mistakenly insert an SFM too quickly after removing it, traffic flow is interrupted. To correct the situation, remove an active SFM or the standby SFM, wait several seconds, and reinsert. System messages stating that the active interfaces' status changed and the switch fabric is up appear when an fifth SFM is inserted correctly and traffic is flowing.

Removing and Replacing the Air Filter

A factory-installed air filter is shipped with the E600i system. The hot-swappable air filter prevents large particles, debris, and dust from entering and circulating through the system, and ensures proper air flow through the system. Filters should be inspected monthly and replaced every twelve months or as required.

Figure 10-4. Replacing the E600i Air Filter

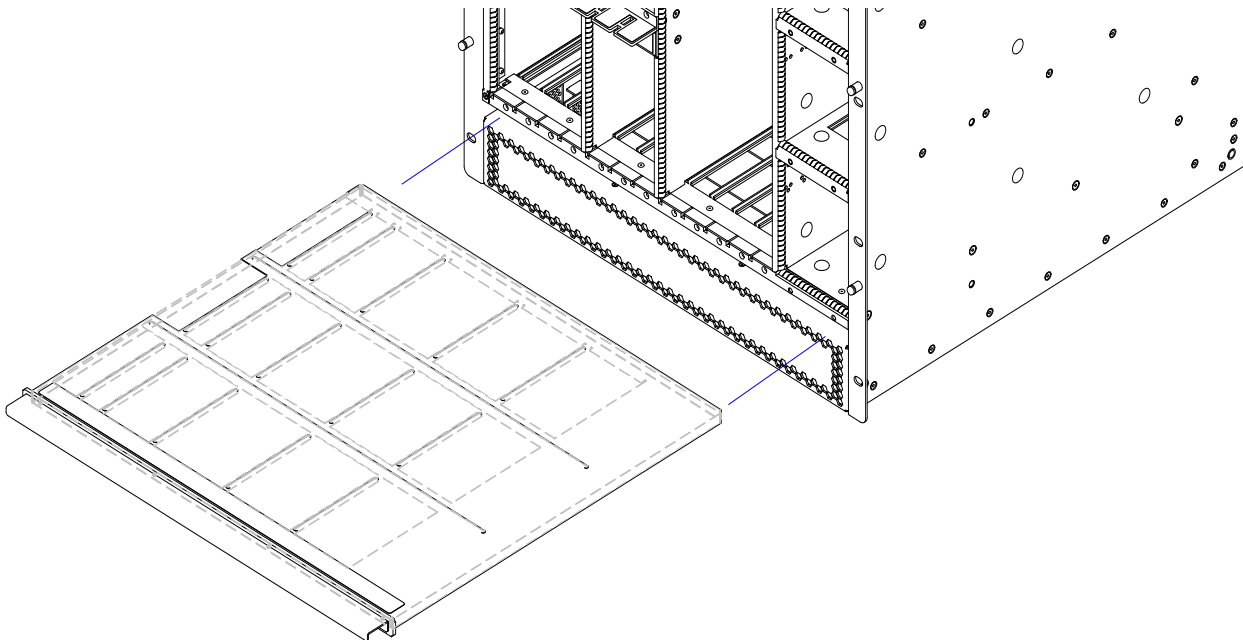

 **WARNING:** An improperly installed air filter will restrict air flow and will generate thermal problems throughout the chassis. Ensure the air filter is oriented correctly and seated securely in the slot.

 **WARNING:** Do not operate without a filter for any longer than 3 minutes to avoid card over-temperature conditions.

To remove and replace the air filter:

Step	Task
1	Pull the air filter straight out of the chassis to remove.
2	Rotate the replacement filter so that the side with the label “This Side Up” is facing upward. Guide the filter firmly into the slot until it stops.

Using a Flash Memory Card

This appendix provides information about using an external flash memory card and contains the following sections:

- [External Flash Memory Card Overview](#)
- [Formatting an External Flash Card](#)
- [Inserting the External Flash Memory Card](#)
- [Removing the External Flash Memory Card](#)
- [Copying Files to the External Flash](#)
- [Displaying Files Stored on the External Flash](#)

External Flash Memory Card Overview

Each RPM card is designed with a slot to accommodate an external flash memory card (slot0:). You can use a flash card to copy the image and configuration files for storage and backup purposes. For complex configurations, use the copies for other E600i systems in your network. Configure your boot execution process to use the images stored on a flash card as the primary (active), secondary (standby), or default boot order preference. Optional external flash memory cards are shipped blank.

Inserting the External Flash Memory Card

 **NOTE:** Only insert the external flash before system boot or after the system has completed its boot and is runtime mode.

To install the flash memory card:

Step	Task
1	Press the ejector button to ensure it is in the extended position. Hold the flash card vertically (with the manufacturers able on the left and the barcode on the right).
2	Gently insert the flash card into the primary RPM flash slot until the is card is flush with the front panel. Do not force the flash card into the slot.
3	The In Use LED illuminates only during read or write operations.

Removing the External Flash Memory Card

To remove the flash memory card:

Step	Task
1	Extend the ejector button by pressing the ejector button. Then press the ejector button again to eject the memory card.
2	Remove the card and store it in an antistatic bag.

Formatting an External Flash Card

New external flash cards must be formatted in the E600i before use.

Flash cards used on systems other than the E600i as well as cards formatted on PCs must be reformatted in the E600i flash slot before they can be used. Similar to formatting a new diskette, formatting erases all information stored on the flash card. To format the flash card:

Step	Task
1	Insert the flash card into the flash slot on the <i>primary</i> RPM.
2	In the EXEC CLI mode, enter <code>format slot0:</code>
3	The formatted flash card is ready to use.

Copying Files to the External Flash

Copy files to the flash when you want keep a backup image. The In Use LED illuminates during a read or write operation. Do not eject the flash card from the slot while this LED is lit.

To copy files to the external flash card use the following command:

Command Syntax	Command Mode	Purpose
<code>copy file-url1 file-url2</code>	EXEC Privilege	Configure the following parameters: <ul style="list-style-type: none"> • <i>file-url1</i>: the file source • <i>file-url2</i>: enter <code>slot0://</code>

Displaying Files Stored on the External Flash

Flash cards can be used to copy and store system images, boot images, and configuration files. Optional flash memory cards are shipped blank.

To display files stored on a flash use the following command:

Command Syntax	Command Mode	Purpose
<code>dir [filesystem]</code>	EXEC Privilege	Configure the following optional parameters to view files on the flash card: <ul style="list-style-type: none"> • <i>filesystem</i>: enter either <code>flash:</code> for the internal flash or <code>slot0:</code> for the external flash. The default is <code>flash:</code> (the internal flash). To view the external flash, enter <code>dir slot0:</code>

Figure 11-1. dir Command Example

```
Force10#dir slot0:  
Directory of slot0:  
  
 1  -rwx      6478482   Sep 7 101 16:54:34  E1200.BIN
```

FTOS supports up to a 40-character file name length, up to a 180-character local file path length, and up to a 256-character remote file path length.

Refer to the *FTOS Command Line Interface Reference* for CLI commands.

System Boot

This appendix provides instructions to boot the E600i system from the `BOOT_USER` prompt.

The E600i System Boot Process

When you supply power to the E600i system, the system performs a series of power-on self-tests. RPM, and line card Status LEDs blink during initialization. No user interaction is required as long as the boot process proceeds without interruption. Observe the process on your console monitor and note the message output on the display. When the boot process is complete, the RPM and line card Status LEDs remain online (green) and the console monitor displays the command line interface (CLI) prompt, `Force10>`.

The RPM cards in the E600i system contain an internal flash memory card (`flash:`). This is the default storage area for the boot files and the startup configuration file. Upon system power up or a system reset, the boot process uses parameters stored in non-volatile random access memory (NVRAM) to boot the system.

Each RPM is equipped with a slot for an external flash memory card (`slot0:`). You can copy the image files and configuration files to the external flash device on the *primary* RPM. You can also begin your boot process by accessing a remote server containing the boot image and system image files. When you configure your system to boot, you can specify the boot preference order: primary, secondary, or default in the in the `BOOT_USER` mode and the CLI mode.

 **NOTE:** The E600i system supports up to a 40-character file name length, up to a 180-character local file path length, and up to a 256-character remote file path length.

For information about the flash memory card, see [Chapter 11, Using a Flash Memory Card](#).

Booting from the `BOOT_USER` Prompt

To get into the `BOOT_USER` mode, you can issue a break control sequence (`CNTL+^`) to interrupt the automatic boot process or if you experience boot problems. This mode allows you to modify the parameters necessary to manage the boot process. Only console port access is enabled for the `BOOT_USER` mode.

To configure the chassis from the `BOOT_USER` prompt:

- 1 `help`
or
`?`
 - The `BOOT_USER #` prompt appears after an autoboot interruption. This is the default boot prompt, not the CLI prompt.
 - Enter `help` or `?` to display a list of available commands and syntax.
 - Enter `syntax help` to display syntax information and variable descriptions.
 - Some display output you are given the option to continue the help screen display `<cr>` or to stop `q<cr>`.
 - You can abbreviate the boot commands by entering only the first letter of a command word. A matching algorithm displays the commands starting with the letter or letters you entered. For example, `b` displays the commands starting with the letter `b`, `boot change` and `boot selector`. Entering `s h` displays the syntax help information.
 - All commands are case insensitive.

- 2 Execute the following `show` commands to display important boot information:
`show boot selector`

The `show boot selector` command displays the boot ROM image currently selected and the most recently booted ROM image.

```
BOOT_USER # show boot selector

ROM BOOTSTRAP SELECTOR PARAMETERS:
=====
```

- 3 `show bootflash`

This command displays information about the current boot ROM.

```
BOOT_USER # show bootflash

GENERAL BOOTFLASH INFO
=====
Bootflash Partition A:
  Forcel0 Networks System Boot
  Copyright 1999-2001 Forcel0 Networks, Inc.
  ROM Header Version 1.0
  Official CP_IMG_BOOT, BSP Release 2.0.0.14
  Created Fri Sep  2 18:22:47 US/Pacific 2004

Bootflash Partition B:
```

4

show bootvar

This command displays the current operating system boot configuration parameters.

```

BOOT_USER # show bootvar

PRIMARY OPERATING SYSTEM BOOT PARAMETERS:
=====
boot device           : flash
file name             : /E600i-x.bin

SECONDARY OPERATING SYSTEM BOOT PARAMETERS:

```

5

boot change {primary | secondary | default}

If your configuration displays no pre-configured operating system boot parameters, use the **boot change** command to edit appropriate fields.

- The **primary** operating system boot parameters are used in the first attempt to boot the system.
- The **secondary** operating system boot parameters are used if the primary operating system boot selection is not available.
- The **default** operating system boot parameters are used if the secondary operating system boot parameter selection is not available. The default parameters always reside on the internal flash device (flash:).

 **NOTE:** These parameters, as well as other boot parameters, can be modified in the CLI mode.

When you enter the **boot change** command, you are prompted for a response.

- Enter a new parameter or press the ENTER key (carriage return) to accept the default parameter.
- Enter . (period) to clear a field.
- Enter - (dash) to edit a field above the current cursor position.

 **NOTE:** When you enter a new parameter that extends beyond 80 characters, you cannot use the BACKSPACE key to correct any mistakes. If you make a mistake, you must re-enter the parameter.

```

BOOT_USER # boot change primary
'.' = clear field; '-' = go to previous field
boot device           : flash
file name             : /E600i-6.x.bin
BOOT_USER # boot change default
'.' = clear field; '-' = go to previous field
boot device           : flash
file name             : /E600i-6.x.bin

BOOT_USER #

```

- 6
- interface management port config 100m
 - interface management port config 10m
 - interface management port config auto-negotiate
 - interface management port config no auto-negotiate
 - interface management port config full-duplex
 - interface management port config half-duplex
 - interface management port config show
- (OPTIONAL) Use these commands to set the speed and duplex settings for the Management interface. The default setting is full-duplex and auto-negotiation.
 - Use the `interface management port config show` command to view the Management interface's physical settings.
- 7
- show interface management ethernet
 - interface management ethernet ip address *ip-address ip-address-mask*
- Use the `show interface management ethernet` command to display the IP address and network mask of the management Ethernet port.
 - If the `show` command output does not display configured IP address information, use the `interface management ethernet ip address ip-address ip-address-mask` command to set the IP address of the Management Ethernet port for network (ftp/tftp) operating system boot.

```

BOOT_USER # show interface management ethernet
No IP address set for interface management ethernet 0/0!

BOOT_USER # interface management ethernet ip address 1.2.3.4 255.255.0.0
Management ethernet 0/0 IP address: 1.2.3.4 255.255.0.0

BOOT_USER # show interface management ethernet

Management ethernet IP address: 1.2.3.4:ffffff00

BOOT_USER #

```

- 8
- show default-gateway
 - default-gateway *ip-address*
- (OPTIONAL) Use the `show default-gateway` command to view gateway information.
 - If your server is on the same subnet, you do not need to configure a gateway parameter.
 - If your server is not on the same subnet, use the `default-gateway ip-address` command to set the gateway IP address.

```

BOOT_USER # show default-gateway

No gateway IP address specified!

BOOT_USER # default-gateway ip 1.2.3.5
Gateway IP address 1.2.3.5
BOOT_USER # show default-gateway

Gateway IP address: 1.2.3.5

BOOT_USER #

```

-
- 9 **dir flash:** Use the **dir flash:** command to list files stored on the internal flash device.
 dir slot0: Use the **dir slot0:** command to list files stored on the external flash device.

```
BOOT_USER # dir flash:
Displaying files in flash:
  size      date      time      name
-----
11187685   FEB-15-2006  05:37:58  E600i-.bin
11031398   FEB-23-2006  22:42:46  E600i-3.bin
 9280984   FEB-17-2006  21:02:36  E600i-2.bin
10778521   FEB-18-2006  22:53:26  E600i-3.1.bin
   1787    FEB-23-2006  22:42:46  startup-config

BOOT_USER #
```

- 10 **reload** Reload software.
 The autoboot program initializes and displays self-test results on the console screen.
  **NOTE:** Do not press break control sequence at any time during the boot/reboot process. Doing so causes the boot process to terminate.
- 11 **Force10>** When the reboot completes, the CLI defaults to the EXEC mode.
-

Refer to the *FTOS Command Line Interface Reference* for CLI details, and to the *FTOS Configuration Guide* for configuration procedures.

Alarms

The E600i generates major and minor alarms for the following conditions:

- fan tray status
- power supply status
- RPMs status
- high temperature on RPMs
- line cards status
- high temperature on line cards
- SFMs status
- high temperature on SFMs.

A major alarm is any fault that may render the E600i non-functional.

A minor alarm is any fault that threatens the operation of the E600i.

You can monitor alarm conditions on the E600i system through the console, LEDs, and audible alarms. If you configure the SNMP command (`snmp-server enable traps envmon`), the FTOS also sends an SNMP trap.

In the E600i system, alarms are logged for each occurrence, but the system may not send an event log for multiple occurrences. For example, whenever a module exceeds the shutdown threshold, the module shuts down. If more than one module exceeds the warning or high temperature thresholds within a five minute period, the system generates one event for all effected modules, but alarms are logged for each occurrence. If the modules temperature falls to 5° lower than the warning threshold temperature, the system clears the alarm and an SNMP trap.

Table B-1. Alarm Events and Reporting

Module	Alarm Event	Alarm LED	Reported in event log	Status LED on Module	Audible Alarm?
Fan tray	More than one fan within the module fails or hardware failure in the module	major (red)	major	amber	yes
	One fan within the module fails	minor (amber)	minor	amber	no
AC Power Supplies	Hardware failure in a non-redundant power configuration (3 power supplies)	major (red)	major	red or unlit	yes
	Hardware failure in a redundant power configuration (4 power supplies)	minor (amber)	minor	red or unlit	no

Table B-1. Alarm Events and Reporting

Module	Alarm Event	Alarm LED	Reported in event log	Status LED on Module	Audible Alarm?
Line Card	Hardware failure	major (red)	major	amber	no
	Exceeds high temperature limit	major (red)	major	unlit	yes
	Exceeds warning temperature limit	minor (amber)	minor	green	yes
	Individual interface fails	minor (amber)	reported	amber ^a	no
RPM (Non-redundant Configuration with 1 RPM)					
	Exceeds high temperature limit	major (red)	major	unlit	yes
	Exceeds warning temperature limit	minor (amber)	minor	green	no
	RPM fails but CP is ok	major (red)	major	amber	yes
SFMs (Redundant Configuration with 5 SFMs)					
	Exceeds high temperature limit	major (red)	major	unlit	yes
	Exceeds warning temperature limit	minor (amber)	minor	green	no
	Any card fails	minor (amber)	minor	amber	no
	Any card removed	minor (amber)	minor	unlit	no
SFMs (Non-Redundant Configuration with 4 SFMs)					
	Exceeds high temperature limit	major (red)	major	unlit	yes
	Exceeds warning temperature limit	minor (amber)	minor	green	no
	Any card fails	major (red)	major	amber	yes
	Any card removed	major (red)	major	unlit	yes

a. The interface's Link LED is unlit.

AC Power Supplies and Alarms

During system boot, if the redundant power supply (the fourth power supply) is missing or fails, the FTOS does not generate any alarm messages since the minimum configuration of three power supplies is operating. Yet, if a fourth AC power supply is installed, and later one of the four power supplies is removed or fails, the system generates a minor alarm.

If only three power supplies are installed and one of them fails while the E600i is operating, the software generates a major alarm and an SNMP trap, lights the major LED, and activates the audible alarm.

When you operate the E600i with three AC power supplies and six or more line cards, the software lists a redundancy alarm on the console and in the show alarms command output. All line cards operate normally.

SFMs and Alarms

The number of SFMs present in the system when it boots determines the level of alarms sent when a fifth (redundant) SFM is removed or fails. At boot time, if five SFMs are present and functioning, the E600i system issues no alarms. However, if one SFM fails or is removed, the system send a minor alarm stating that four SFMs are present. The system requires four functioning SFMs to pass traffic.

At boot time, if four SFMs are present and functioning, the E600i system issues no alarms. The system issues no alarms if a fifth SFM is added to the system; however, if the number of functioning SFMs changes from five to four, the system sends a minor alarm event. The system always triggers a major alarm when the number of working SFMs reaches three.

System Specifications

This appendix contains the following major sections:

- [Chassis Physical Design](#)
- [AC Power Supply Unit Requirements](#)
- [DC Power Entry Module Requirement](#)
- [Agency Compliance](#)

Chassis Physical Design

Parameter	Specifications
Height	28 inches (71.1 cm)
Width	17.4 inches (44.2 cm)
Depth (without cable management system)	21.5 inches (54.6 cm)
Chassis weight with factory-installed components (backplane and air filter)	81 pounds (36.7 kg)
Weight fully loaded (backplane, air filter, fan tray, SFMs, RPMs, and 7 line cards)	242 pounds (109.8 kg)
Mounting	Factory-installed rack mount brackets for front, center, or rear mounting in a standard 19-inch rack. Optional brackets for mounting in a standard 23-inch rack or cabinet.
Rack clearance required	Front: 18-inches Rear: 20-inches
Maximum Thermal output:	
 NOTE: Thermal output is directly proportional to system configuration and number of line cards.	
• Maximum for fully loaded chassis	120 VAC powered: 4705W (16,065 BTU/hour) 200/240 VAC powered: 4250W (14,500 BTU/hour) DC powered: 2800W (9600 BTU/hour)

Environmental

Parameter	Specifications
Operating:	
Temperature	32° to 104°F (0° to 40°C)
Maximum altitude	No performance degradation to 10,000 feet (3,048 meters)
Relative humidity	5 to 85 percent, noncondensing
Non-operating:	
Temperature	-40° to 158°F (-40° to 70°C)
Maximum altitude	15,000 feet (4,572 meters)
Relative humidity	5 to 95 percent, noncondensing

AC Power Supply Unit Requirements

Parameter	Specifications
Nominal Input Voltage	120 - 240 VAC 50/60 Hz
Maximum AC Power Supply Input	16 A @ 100 VAC per module 12 A @ 200 VAC per module
Maximum Thermal Output (3,172 W)	10,822 BTU/hour at 100/120 VAC
Maximum Thermal Output (2,906 W)	9,914 BTU/hour at 200/240 VAC
Maximum AC Supply Input Current (based on 2500 W output for 100/120V and 200/240V lines.)	11.6 A @ 100 VAC 9.7 A @ 120 VAC 8.0 A @ 200 VAC 6.7 A @ 240 VAC
Maximum System Power Input	3.5 KVA @ 100/120 VAC 3.2 KVA @ 220/240 VAC
Maximum Power Consumption	3,422 W at 100/120 VAC 3,156 W at 200/240 VAC

DC Power Entry Module Requirement

Parameter	Specifications
Nominal Input Voltage	-44 to 60 VDC
Maximum Current Draw (per DC PEM)	100 A
Maximum Thermal Output (2,590 W)	8,838 BTU/hour
Maximum Power Consumption	2,840 W

SFM and RPM Power Requirements

Module	Power Requirement in Watts (in BTUs)
SFM	60W (210 BTU/hour)
RPM	150W (510 BTU/hour)

Agency Compliance

The E600i is designed to comply with the following safety and agency requirements.

USA Federal Communications Commission (FCC) Statement

This equipment has been tested and found to comply with the limits for a Class A digital device, pursuant to Part 15 of the FCC rules. These limits are designated to provide reasonable protection against harmful interference when the equipment is operated in a commercial environment. This equipment generates, uses, and can radiate radio frequency energy. If it is not installed and used in accordance to the instructions, it may cause harmful interference to radio communications. Operation of this equipment in a residential area is likely to cause harmful interference, in which case users will be required to take whatever measures necessary to correct the interference at their own expense.

Properly shielded and grounded cables and connectors must be used in order to meet FCC emission limits. Dell Force10 is not responsible for any radio or television interference caused by using other than recommended cables and connectors or by unauthorized changes or modifications in the equipment. Unauthorized changes or modification could void the user's authority to operate the equipment.

This device complies with Part 15 of the FCC Rules. Operation is subject to the following two conditions: (1) this device may not cause harmful interference, and (2) this device must accept any interference received, including interference that may cause undesired operation.

Canadian Department of Communication Statement

Industry Canada Class A emission compliance statement

This Class A digital apparatus complies with Canadian ICES-003.

Avis de conformité à la réglementation d'Industrie Canada

Cet appareil numérique de la classe A est conforme à la norme NMB-003 du Canada.

European Union EMC Directive Conformance Statement

This product is in conformity with the protection requirements of EU Council Directive 2004/108/EC on the approximation of the laws of the Member States relating to electromagnetic compatibility. Dell Force10 can not accept responsibility for any failure to satisfy the protection requirements resulting from a non-recommended modification of this product, including the fitting of non-Dell Force10 option cards.

This product has been tested and found to comply with the limits for Class A Information Technology Equipment according to CISPR 22/ European Standard EN 55022. The limits for Class A equipment were derived for commercial and industrial environments to provide reasonable protection against interference with licensed communication equipment.

 **WARNING:** This is a Class A product. In a domestic environment, this device may cause radio interference, in which case, the user may be required to take adequate measures.

European Community Contact

Dell Force10, EMEA - Central
Dahlienweg 19
66265 Heusweiler
Germany

<http://www.force10networks.com/german/>

Tel: +49 172 6802630

Email: EMEA Central Sales

Japan: VCCI Compliance for Class A Equipment

この装置は、情報処理装置等電波障害自主規制協議会（VCCI）の基準に基づくクラスA情報技術装置です。この装置を家庭環境で使用すると電波妨害を引き起こすことがあります。この場合には使用者が適切な対策を講ずるよう要求されることがあります。

This is Class A product based on the standard of the Voluntary Control Council For Interference by Information Technology Equipment (VCCI). If this equipment is used in a domestic environment, radio disturbance may arise. When such trouble occurs, the user may be required to take corrective actions.

⚠ WARNING: AC Power cords are for use with Dell Force10 equipment only. Do not use Dell Force10 AC power cords with any unauthorized hardware.

本製品に同梱いたしております電源コードセットは、本製品専用です。本電源コードセットは、本製品以外の製品ならびに他の用途でご使用いただくことは出来ません。製品本体には同梱された電源コードセットを使用し、他製品の電源コードセットを使用しないで下さい。

Korea (MIC certification)

Korean Class A Warning Statement

이 기기는 업무용으로 전자파 적합등록을 받은 기기 이오니, 판매자 또는 사용자는 이점을 주의하시기 바라며, 만약 잘못 구입하셨을 때에는 구입한 곳에서 비업무용으로 교환하시기 바랍니다.

Korea (KCC Certification)

A급 기기

(업무용 방송통신기자재)

이 기기는 업무용(A급) 전자파적합기기로서 판매자 또는 사용자는 이 점을 주의하시기 바라며, 가정외의 지역에서 사용하는 것을 목적으로 합니다.

Korea Information

	 [equipment type]
품명(Product Name)	Ethernet Switch
모델명(Model)	[model number]
신청인(Applicant)	Force10 Networks, Inc.
제조사(Manufacturer)	Delta Networks, (Dongguan) Ltd.
제조년월(Manufacturing Date)	[date]
제조국(Country of Origin)	China

Safety Standards and Compliance Agency Certifications

- CUS UL (60950-1, 1st Edition)
- CSA 60950-1-03, 1st Edition
- EN 60950-1, 1st Edition
- EN 60825-1, 1st Edition
- EN 60825-1 Safety of Laser Products—Part 1: Equipment Classification Requirements and User's Guide
- EN 60825-2 Safety of Laser Products—Part 2: Safety of Optical Fibre Communication Systems
- FDA Regulation 21CFR 1040.10 and 1040.11
- IEC 60950-1, 1st Ed, including all National Deviations and Group Differences

Electromagnetic Compatibility (EMC)

Emissions

- Australia/New Zealand: AS/NZS CISPR 22: 2006, Class A
- Canada: ICES-003, Issue-4, Class A
- Europe: EN55022 2006 (CISPR 22: 2006), Class A
- Japan: VCCI V3/ 2007.04 Class A
- USA: FCC CFR47 Part 15, Subpart B, Class A

Immunity

- EN 300 386 V1.3.3: 2005 EMC for Network Equipment
- EN 55024 1998 + A1: 2001 + A2: 2003
 - EN 61000-3-2 Harmonic Current Emissions
 - EN 61000-3-3 Voltage Fluctuations and Flicker
 - EN 61000-4-2 ESD
 - EN 61000-4-3 Radiated Immunity
 - EN 61000-4-4 EFT
 - EN 61000-4-5 Surge
 - EN 61000-4-6 Low Frequency Conducted Immunity

Product Recycling and Disposal

This switch must be recycled or discarded according to applicable local and national regulations. Dell Force10 encourages owners of information technology (IT) equipment to responsibly recycle their equipment when it is no longer needed. Dell Force10 offers a variety of product return programs and services in several countries to assist equipment owners in recycling their IT products.

Waste Electrical and Electronic Equipment (WEEE) Directive for Recovery, Recycle and Reuse of IT and Telecommunications Products

Dell Force10 switches are labeled in accordance with European Directive 2002/96/EC concerning waste electrical and electronic equipment (WEEE). The Directive determines the framework for the return and recycling of used appliances as applicable throughout the European Union. This label, as shown in [Figure C-1](#), is applied to various products to indicate that the product is not to be thrown away, but rather reclaimed upon end of life per this Directive.

Figure C-1. The European WEEE symbol



In accordance with the European WEEE Directive, electrical and electronic equipment (EEE) is to be collected separately and to be reused, recycled, or recovered at end of life. Users of EEE with the WEEE marking per Annex IV of the WEEE Directive, as shown above, must not dispose of end of life EEE as unsorted municipal waste, but use the collection framework available to customers for the return, recycling and recovery of WEEE. Customer participation is important to minimize any potential effects of EEE on the environment and human health due to the potential presence of hazardous substances in EEE.

Dell Force10 products, which fall within the scope of the WEEE, are labeled with the crossed-out wheeled-bin symbol, as shown above, as required by WEEE.

For information on Dell Force10 product recycling offerings, see the WEEE Recycling instructions on iSupport at: <https://www.force10networks.com/CSPortal20/Support/WEEEandRecycling.pdf>.

For more information, contact the Dell Force10 Technical Assistance Center (TAC) (see [Contacting the Technical Assistance Center on page 72](#)).

For California:

Perchlorate Material — Special handling may apply.

See: <http://www.dtsc.ca.gov/hazardouswaste/perchlorate>

The foregoing notice is provided in accordance with California Code of Regulations Title 22, Division 4.5 Chapter 33. Best Management Practices for Perchlorate Materials.

Technical Support

This appendix contains these major sections:

- [The iSupport Website](#)
- [Contacting the Technical Assistance Center on page 72](#)
- [Requesting a Hardware Replacement on page 73](#)
- [Requesting a Hardware Replacement on page 73](#)

The iSupport Website

iSupport provides a range of documents and tools to assist you with effectively using Dell Force10 equipment and mitigating the impact of network outages. Through iSupport you can obtain technical information regarding Dell Force10 products, access to software upgrades and patches, and open and manage your Technical Assistance Center (TAC) cases. Dell Force10 iSupport provides integrated, secure access to these services.

The iSupport website (<http://www.force10networks.com/support/>) contains a publicly available interface that includes access to techtips, white papers, and user manuals. After you get an account and log in, the available documentation expands to other types, including bug lists, error message decoder, release notes. You can even track your own Dell Force10 inventory.

Once you are logged in, the following five tabs become available:

- **Home:** Summary of open cases, RMA management, and field notices (as shown below)
- **Service Request:** Case management
- **Software Center:** Software downloads, bug fixes, and bug tracking tool
- **Documents:** User documentation, FAQs, field notices, technical tips, and white papers
- **Support Programs:** Information on the suite of Dell Force10 support and professional support services.

The *Support Guide*, available on Support Policies section of iSupport, details the types of information and services that you can access through iSupport and through various types of support contracts.

Accessing iSupport Services

The URL for iSupport is <http://www.force10networks.com/support/>. To access iSupport services you must have a userid and password. If you do not have one, you can request one at the website:

- 1 On the Dell Force10 iSupport page, click the **Account Request** link.
- 2 Fill out the User Account Request form, and click **Send**. You will receive your userid and password by E-mail.

- 3 To access iSupport services, click the **LOGIN** link, and enter your userid and password. See [Contacting the Technical Assistance Center](#), below, for more.

Contacting the Technical Assistance Center

How to Contact Dell Force10 TAC	Log in to iSupport at http://www.force10networks.com/support/ , and select the Service Request tab.
Information to Submit When Opening a Support Case	<ul style="list-style-type: none"> • Your name, company name, phone number, and E-mail address • Preferred method of contact • Model number • Serial Number (see Requesting a Hardware Replacement) • Software version number • Symptom description • Screen shots illustrating the symptom, including any error messages. These can include: <ul style="list-style-type: none"> • Output from the show tech-support [non-paged] command (This report is very long, so the storage buffer in your terminal program should be set high.) • Output from the show logging eventlog [unit] command, where <i>unit</i> is the stack ID of the member unit that experienced the failure (This report is included as a section in the output of show tech-support.) • Console captures showing the error messages • Console captures showing the troubleshooting steps taken • Saved messages to a syslog server, if one is used
Managing Your Case	Log in to iSupport, and select the Service Request tab to view all open cases and RMAs.
Downloading Software Updates	Log in to iSupport, and select the Software Center tab.
Technical Documentation	Log in to iSupport, and select the Documents tab. This page can be accessed without logging in via the Documentation link on the iSupport page.
Contact Information	<p>E-mail: support@force10networks.com</p> <p>Web: http://www.force10networks.com/support/</p> <p>Telephone:</p> <p>US and Canada: 866.965.5800</p> <p>International: 408.965.5800</p>

Requesting a Hardware Replacement

To request replacement hardware, follow these steps:

Step	Task
1	Determine the part number and serial number of the component. To list the numbers for all components installed in the chassis, use the <code>show hardware</code> command.
2	Request a Return Materials Authorization (RMA) number from TAC by opening a support case. Open a support case by: <ul style="list-style-type: none">• Using the Create Service Request form on the iSupport page (see Contacting the Technical Assistance Center on page 72).• Contacting Dell Force10 directly by E-mail or by phone (see Contacting the Technical Assistance Center). Provide the following information when using E-mail or phone:<ul style="list-style-type: none">• Part number, description, and serial number of the component.• Your name, organization name, telephone number, fax number, and e-mail address.• Shipping address for the replacement component, including a contact name, phone number, and e-mail address.• A description of the failure, including log messages. This generally includes:<ul style="list-style-type: none">• Output from the <code>show tech-support [non-paged]</code> command (This report is very long, so the storage buffer in your terminal program should be set high.)• Output from the <code>show logging eventlog [unit]</code> command, where <i>unit</i> is the stack ID of the member unit that experienced the failure (This report is included as a section in the output of <code>show tech-support</code>.)• Console captures showing the error messages• Console captures showing the troubleshooting steps taken• Saved messages to a syslog server, if one is used



Printed in the U.S.A.

www.dell.com | support.dell.com