

# Panasonic

900MHz Cordless Answering System

Model No. **KX-TCC942-B**  
**KX-TCC936-B**

Pulse-or-tone dialing capability

## Operating Instructions



KX-TCC942-B

**PLEASE READ BEFORE USE  
AND SAVE.**

Caller ID Compatible

Charge the battery for about 15 hours before initial use.

Preparation

Cordless Telephone

Answering System

Useful Information

# Before Initial Use

Please read **IMPORTANT SAFETY INSTRUCTIONS** on pages 75-76 before use. Read and understand all instructions.

*Thank you for purchasing the Panasonic cordless telephone.*

Caller ID and Visual Call Waiting (Call Waiting ID), where available, are telephone company services. After subscribing to Caller ID, this phone will display the caller's name and phone number. An added service, Visual Call Waiting, will display the second caller's name and phone number during call waiting.

Attach your purchase receipt here.

## For your future reference

Serial No. \_\_\_\_\_ Date of purchase \_\_\_\_\_

(found on the bottom of the unit)

Name and address of dealer \_\_\_\_\_

## Accessories

 To order accessories, call 1-800-332-5368.

AC Adaptor (p. 14)  
Part No. KX-A11-6

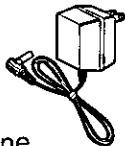

one

Telephone Line Cord (p. 14)



one

Wall Mounting Adaptor (p. 16)

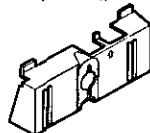

one

Battery (p. 13)  
Part No. P-P592 (KX-A92)



one

Handset Cover (p. 13)



one

Cradle Cover (p. 13)



one

# For Best Performance

---

## Battery Charge

A rechargeable Ni-Cd battery powers the handset. Install the battery (p. 13) and charge it for about **15 hours** before initial use (p. 14).

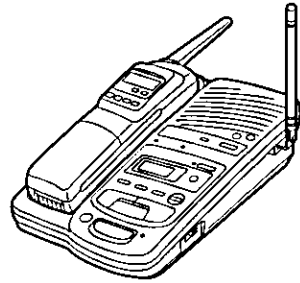

## Operating Distance/Noise

Calls are transmitted between the base unit and the handset using wireless radio waves. **For maximum distance and noise free operation**, the recommended base unit location is:

Away from electrical appliances such as a TV, radio or personal computer.

In a **HIGH** and **CENTRAL** location with no obstructions, such as walls.

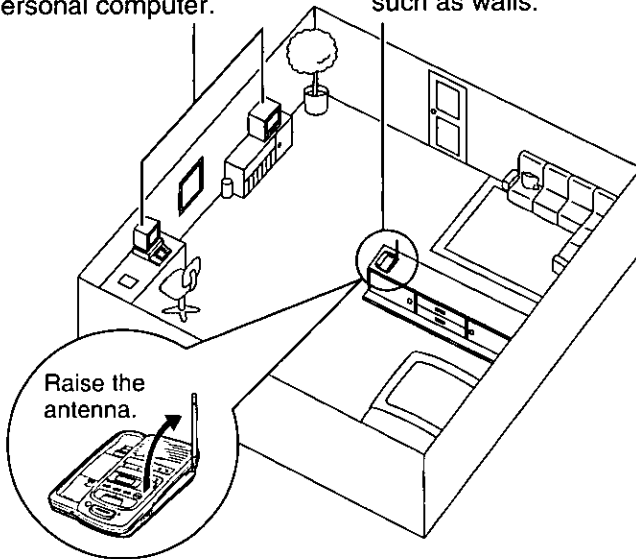

# Contents

---

## *Preparation*

<b>Location of Controls</b> .....	6
<b>Displays</b> .....	10
<b>Settings</b> .....	13
Installing the Battery in the Handset .....	13
Installing the Cradle Cover on the Base Unit .....	13
Connections .....	14
Battery Charge .....	14
Wall Mounting .....	16
Selecting the Dialing Mode .....	17
Storing the Area Code .....	18
Setting the Auto Talk Feature .....	19
<b>Preparing the Answering System</b> .....	20
Greeting Message .....	20
Summary of Programmable Preparations .....	22
Selecting the Caller's Recording Time .....	23
Time and Day Adjustment .....	24
Selecting the Number of Rings.....	26
Setting the CPC (Calling Party Control) Function.....	27
Setting the Greeting Monitor Function.....	27

## *Cordless Telephone*

<b>Making Calls</b> .....	28
<b>Answering Calls</b> .....	30
With the Handset.....	30
With the Base Unit (Digital Duplex Speakerphone).....	32
<b>Automatic Dialing</b> .....	34
Storing Phone Numbers in Memory .....	34
Dialing a Stored Number .....	37
<b>Caller ID Service</b> .....	38
<b>Using the Caller List</b> .....	40
Viewing the Caller List .....	40
Calling Back from the Caller List .....	42
Editing the Caller's Phone Number .....	43

Storing the Caller List Information in Automatic Dialing Memory .....	44
Erasing the Caller List Information .....	45
<b>Intercom</b> .....	46
Transferring a Call Using the Intercom .....	47
<b>Special Features</b> .....	48
For Call Waiting Service Users .....	48
Automatic Security Code Setting .....	49
Temporary Tone Dialing (For Rotary Pulse Service Users) .....	49
If Your Unit is Connected to a PBX (Analog Only) .....	49

### ***Answering System***

<b>Automatic Answering Operation</b> .....	50
Setting the Unit to Answer Calls .....	50
<b>Listening to Messages</b> .....	51
<b>Erasing Messages</b> .....	53
<b>Pager Call</b> .....	54
Storing the Pager Number .....	54
Setting the Unit to Call the Pager .....	55
<b>Remote Operation from a Touch Tone Phone</b> .....	56
Setting the Remote Code .....	57
Voice Menu .....	58
Direct Remote Operation .....	60
<b>Remote Operation with the Handset</b> .....	62
<b>Remote Operation Card</b> .....	65

### ***Useful Information***

<b>Adding Another Phone</b> .....	67
<b>Optional Spare Battery</b> .....	68
<b>Before Requesting Help</b> .....	70
<b>Important Safety Instructions</b> .....	75
<b>FCC and Other Information</b> .....	77

# Location of Controls

## Handset (Front side)

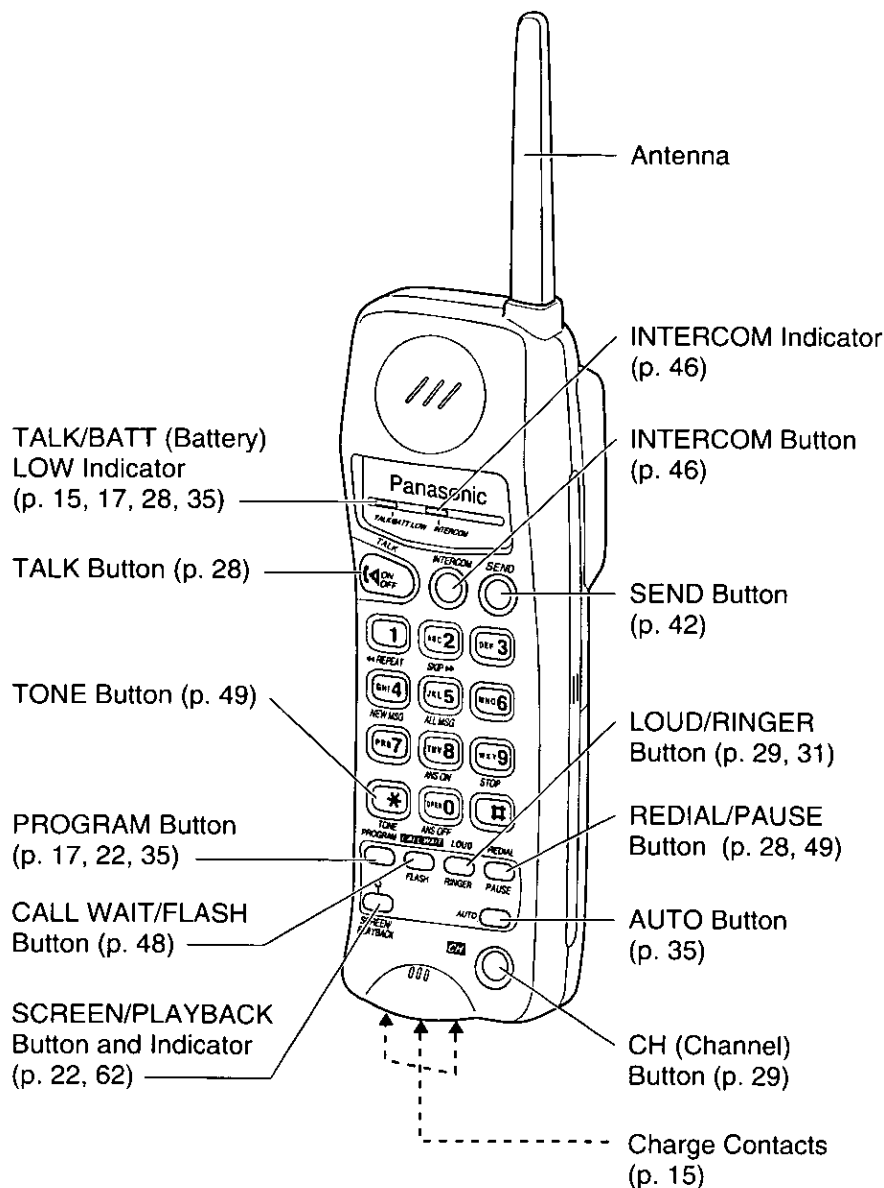

## Handset (Back side)

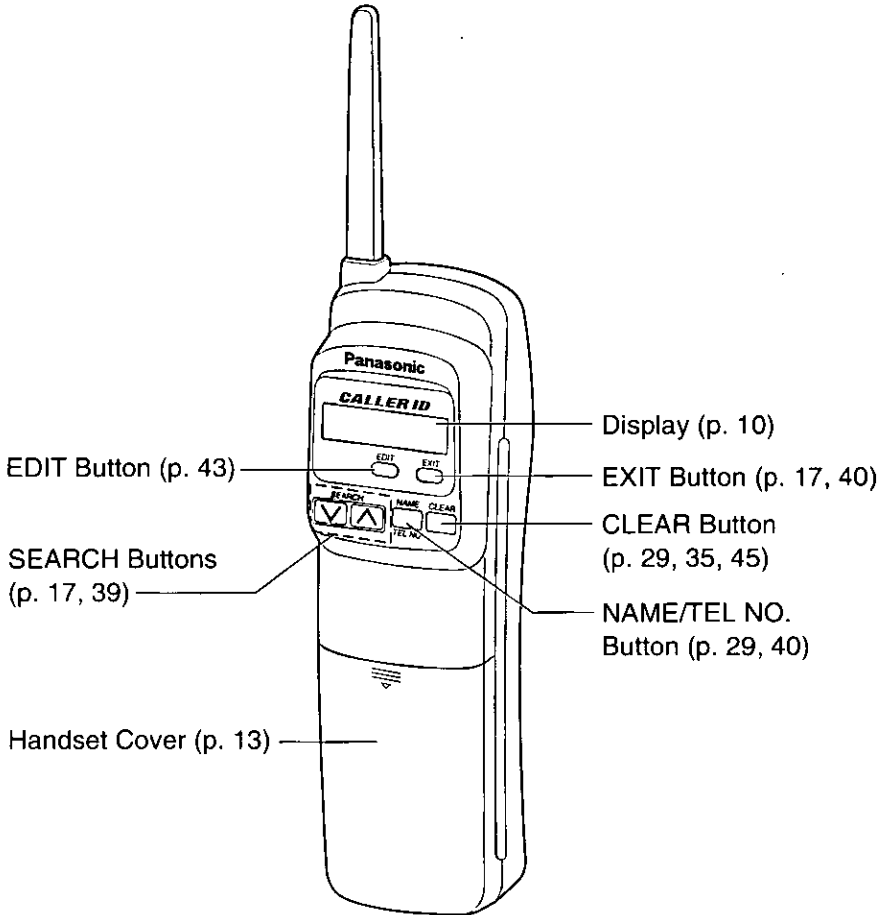
**Illuminated Search Keys**

The **SEARCH** (v, ^) buttons use non-radioactive luminescent material which can absorb light energy of sunlight or lamps (incandescent, fluorescent, halogen, etc.), and release this absorbed light for darkened room operation.

- As the absorbed energy in the **SEARCH** (v, ^) buttons decreases, the button brightness will fade naturally.
- Button brightness and duration depend on the amount of room lighting and exposure time.

## ➔ Location of Controls

### Base unit

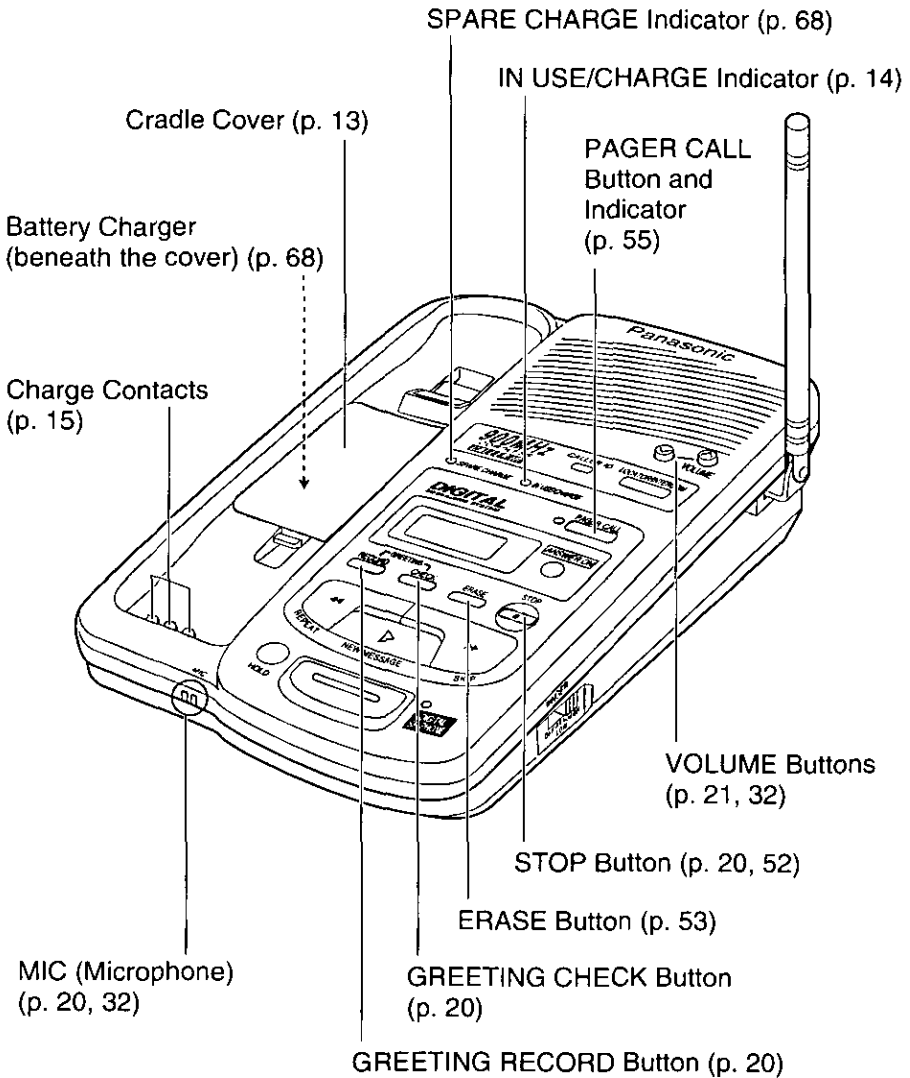



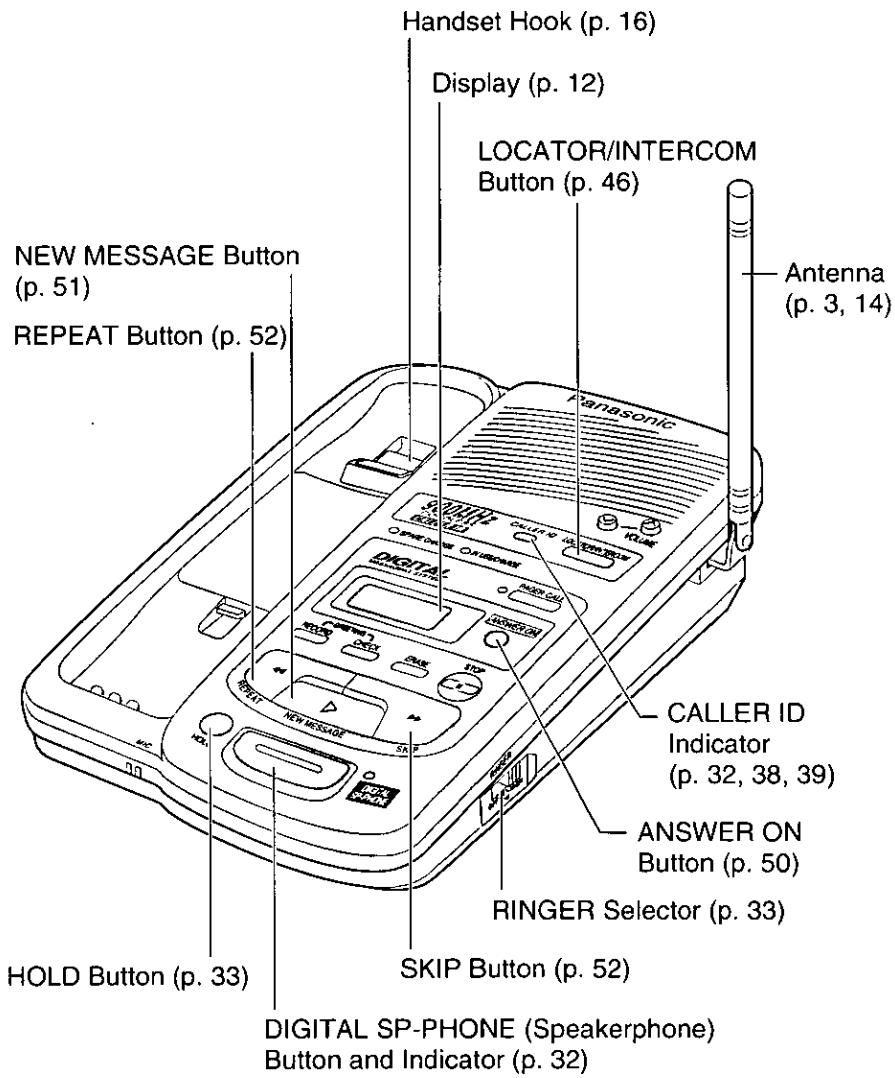

# Displays

---

Both the handset and base unit give you instructions and information on their displays. These display prompts are shown below.

## Handset display

NO CALLERS

The Caller List is empty.

12 NEW CALLS

The display shows the number of new calls while the handset is on the base unit.

12 NEW CALLS

∨=NEW

∧=OLD

This display will be shown when:

- you lift the handset off the base unit, or
- pressing **SEARCH** (∨ or ∧) when the handset is off the base unit.

To search from the most recent call, press **SEARCH** ∨ (NEW key). To search from the oldest call, press **SEARCH** ∧ (OLD key) (p. 40).

01-06-35 CH12

During a conversation, the display counts the length of the call (ex. 1 hour, 6 minutes and 35 seconds). The selected channel number is displayed.

OUT OF RANGE

The handset has lost communication with the base unit (p. 22, 29).

PAGING

The base unit is paging the handset (p. 46).

INTERCOM

00-00-07

CH22

The handset and the base unit are in the intercom mode (p. 46).

INTERCOM HOLD

00-01-12

CH10

An outside call has been put on hold by the handset user in the intercom mode. To release the hold, press **TALK** or **DIGITAL SP-PHONE** (p. 47).



SUSAN HAMMER  
----WAITING----

A second call is received during a conversation (p. 48).

SUSAN HAMMER  
11:20A JAN12 ×3

This is a name from the Caller List. The time and date of the last call (ex. Jan. 12, 11:20 AM) and the number of times called (ex. 3 times) are displayed.

OUT OF AREA

The caller dialed from an area which does not provide the Caller ID service.

PRIVATE CALLER

The caller has requested not to display their information.

END OF NEW CALL

You finished viewing the NEW CALLS in the Caller List. To exit, press **EXIT**.

END OF OLD CALL

You finished viewing the OLD CALLS in the Caller List. To exit, press **EXIT**.

END

You are at the end of the Caller List. To exit, press **EXIT**.

PLEASE LIFT UP  
AND TRY AGAIN

**SEARCH** (v or ^) was pressed while the handset was on the base unit. Lift the handset and press **SEARCH** (v or ^) again.

NOT AVAILABLE

**SEARCH** (v or ^) was pressed while the base unit was engaged in an outside call or the answering system was being operated.

ANSWERING  
SYSTEM SETTING

The unit is in the answering system setting programming mode (p. 22).

REMOTE  
OPERATION CH10

The handset is operating the answering system remotely (p. 62).

## ➔ Displays

---

### Base unit display

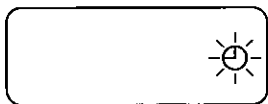

The clock needs adjusting (p. 24).

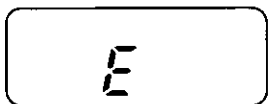

Your greeting message was not recorded correctly. Record it again (p. 20).

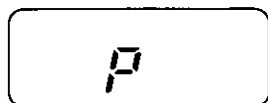

The unit is in programming mode.

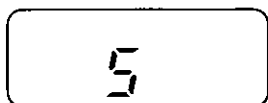

The speaker volume level is set to "5". You can select:

- 9 levels (0-8) while using the answering system (p. 21, 51).
- 8 levels (1-8) while using the speakerphone (p. 32).

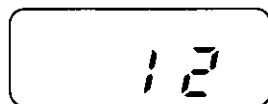

12 messages have been recorded.

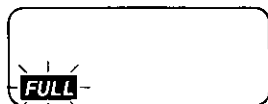

Memory is full. Erase some or all of the messages (p. 53).

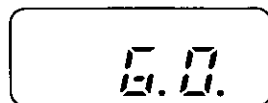

The recording time is set to "greeting only" (p. 23).

# Settings



## Installing the Battery in the Handset

Install the battery as shown observing the proper polarity. Then install the handset cover.

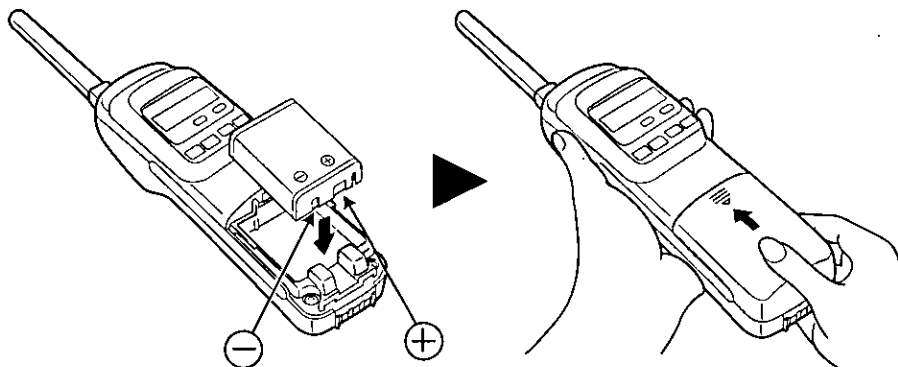

## Installing the Cradle Cover on the Base Unit

Close the cradle cover as shown.

To install an optional spare battery beneath the cradle cover and charge it, see page 68.

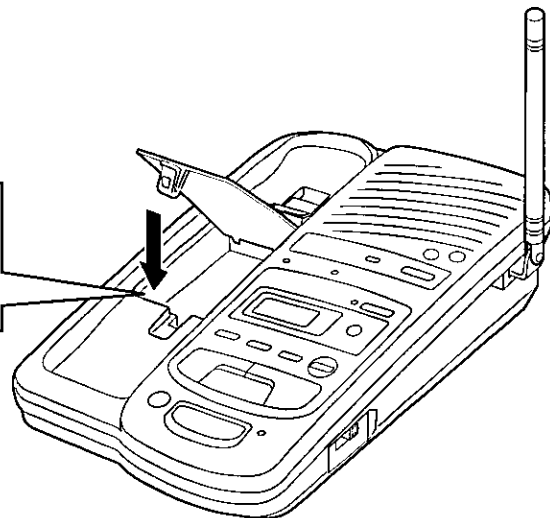

## Connections

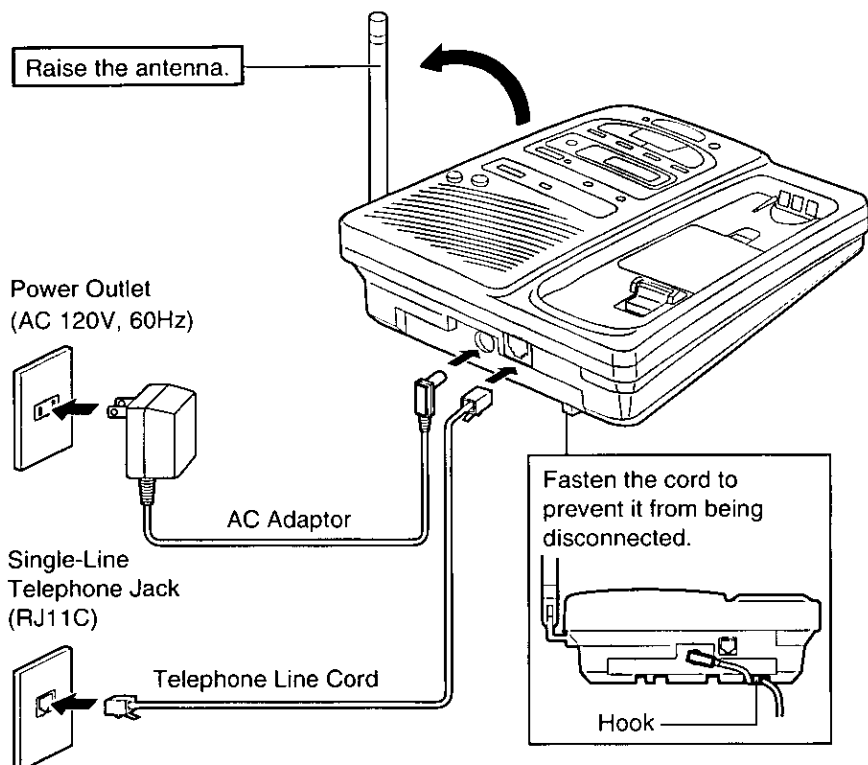

- USE ONLY Panasonic AC ADAPTOR KX-A11.
- The AC adaptor must remain connected at all times. (It is normal for the adaptor to feel warm during use.)
- To connect a standard telephone on the same line, see page 67.
- When the unit is connected to a PBX system, you cannot receive caller information.

## Battery Charge

Place the handset on the base unit and charge for about **15 hours** before initial use.

- The IN USE/CHARGE indicator lights.

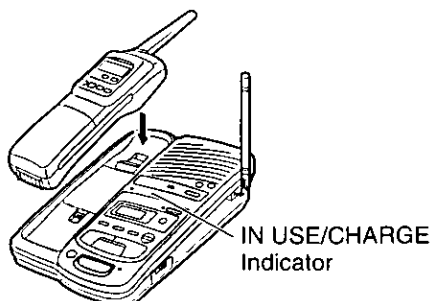



## Recharge

When the TALK/BATT LOW indicator flashes slowly or the unit beeps intermittently, recharge the battery.

- The TALK/BATT LOW indicator will continue to flash for at least 30 minutes once you begin recharging. This time will increase the more you use the handset while recharging.

TALK/BATT LOW Indicator

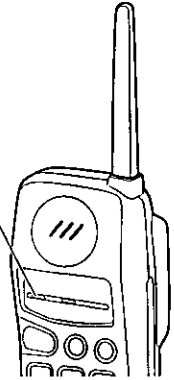

If you do not want to wait until the battery is fully recharged, we recommend you purchase an optional spare battery (page 68).

## Battery information

If your Panasonic battery is fully charged;

While in use (TALK)	Up to about 4.5 hours
While not in use (Stand-By)	Up to about 14 days

- Battery life may be shortened depending on usage conditions, such as viewing the Caller ID Caller List, and ambient temperature.
- **Clean the handset and the base unit charge contacts with a soft dry cloth once a month. Clean more often if the unit is subject to grease, dust or high humidity.** If not, the battery may not charge properly.
- A fully charged battery does not require the handset to be placed on the base unit until the TALK/BATT LOW indicator flashes slowly. This will maximize the battery life.
- The battery cannot be overcharged.

## Stand-by mode (The handset is off the base unit.)

The handset goes into the stand-by mode a few seconds after you finish using the handset (making a call, viewing the caller list, etc.). The handset display is blank, but the handset can receive calls. The battery life is conserved in this mode.

### Wall Mounting

This unit can be mounted on a wall phone plate.

- 1 Pull down the handset hook until it locks **so the tab holds the handset.**

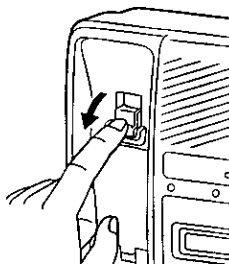

- 2 Connect the AC adaptor. Tuck the telephone line cord inside the wall mounting adaptor, then push it in the direction of the arrow.

- The word "UP" should face upward.

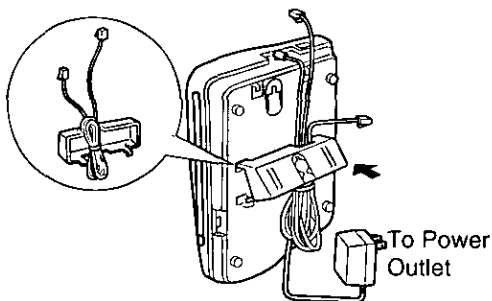

- 3 Connect the telephone line cord. Mount the unit, then slide down.

- Raise the antenna.

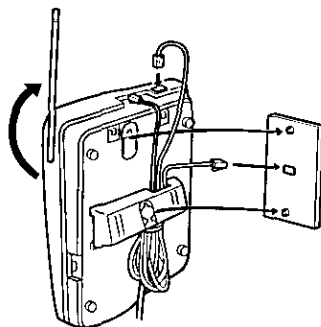

- 4 **To charge the handset battery:** Place the handset on the handset hook as shown.

- The IN USE/CHARGE indicator lights.

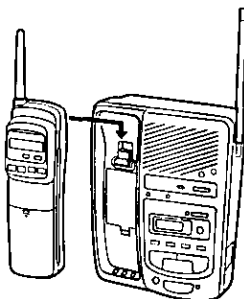





## Selecting the Dialing Mode

You can program the dialing mode using the handset close to the base unit. If you have touch tone service, set to TONE. If rotary pulse service is used, set to PULSE. The factory preset is TONE.

**The TALK/BATT LOW and DIGITAL SP-PHONE indicator lights must be off before programming.**

1 Press **PROGRAM**.

- The TALK/BATT LOW indicator flashes.

SAVE AUTO# ?
∇=NEXT    ^=YES

2 Press **SEARCH** ∇ (NEXT key) twice until "SET DIAL MODE ?" is displayed.

SET DIAL MODE ?
∇=NEXT    ^=YES

3 Press **SEARCH** ^ (YES key).

DIAL MODE
∇=TONE    ^=PULSE

4 To select PULSE, press **SEARCH** ^.  
OR  
To select TONE, press **SEARCH** ∇.

DIAL MODE
PULSE

- A confirmation tone sounds.\*
- The selected mode is displayed.
- In a few seconds, the handset will return to the stand-by mode.

DIAL MODE
TONE

- To cancel, press **EXIT** or **PROGRAM**, then start from step 1.
- If the display shows "SAVE ERROR", move closer to the base unit and try again. If "SAVE ERROR" is still displayed, place the handset on the base unit. Restart from step 1.

### \*What the confirmation tone means

- 1 beep: The mode is different from a previously selected one.
- 2 beeps: The mode is the same as a previously selected one.

### Storing the Area Code

You have to program your area code first before using the Caller ID feature (p. 38). Then incoming calls from the same area will be recorded in the Caller List without the code. You do not have to remove the area code before storing or calling back. Also, when incoming calls from a different area code are received, "1" will be added before the area code automatically.

**The TALK/BATT LOW indicator light must be off before programming.**

- 1 Press **PROGRAM**.
  - The TALK/BATT LOW indicator flashes.

SAVE AUTO# ?
∨=NEXT     ^=YES
- 2 Press **SEARCH** ∨ (NEXT key).

SAVE AREA CODE?
∨=NEXT     ^=YES
- 3 Press **SEARCH** ^ (YES key).
  - The current setting is displayed.  
The factory preset is "---".

AREA CODE = ---
ENTER AREA CODE
- 4 Enter your area code.
  - If you enter a wrong number, press **CLEAR**, then enter the correct number.

AREA CODE = 123
PROGRAM=SAVE
- 5 When finished, press **PROGRAM**.
  - The stored number is displayed.
  - In a few seconds, the handset will return to the stand-by mode.

AREA CODE = 123
-----------------

• To cancel, press **EXIT**, then start from step 1.

### To erase the area code

1. Press **PROGRAM**.
2. Press **SEARCH** ∨ (NEXT key).
3. Press **SEARCH** ^ (YES key).
4. Press **CLEAR**.
5. Press **PROGRAM**.

## Setting the Auto Talk Feature

The Auto Talk feature allows you to answer a call by lifting the handset off the base unit without pressing **TALK**. If you want to view caller's information on the display after lifting the handset, turn this feature OFF by programming. The factory preset is ON.

**The TALK/BATT LOW indicator light must be off before programming.**

1 Press **PROGRAM**.

- The TALK/BATT LOW indicator flashes.

SAVE AUTO# ?
∇=NEXT      ^=YES

2 Press **SEARCH** ∇ (NEXT key) 3 times until "TALK SWITCHING?" is displayed.

TALK SWITCHING?
∇=NEXT      ^=YES

3 Press **SEARCH** ^ (YES key).

AUTO TALK
∇=ON      ^=OFF

4 To select OFF, press **SEARCH** ^.  
OR

To select ON, press **SEARCH** ∇.

- The selected mode is displayed.
- In a few seconds, the handset will return to the stand-by mode.

AUTO TALK	OFF
-----------	-----

AUTO TALK	ON
-----------	----

- To cancel, press **EXIT** or **PROGRAM**, then start from step 1.
- To answer a call when the Auto Talk feature is OFF, lift the handset off the base unit, then press **TALK**.

# Preparing the Answering System

## Greeting Message

You can record a personal greeting message. If you do not record one, a pre-recorded greeting will be played when a call is received (p. 21).

All messages (greeting, incoming, etc.) are stored in digital memory (p. 52). The **total recording time is about 14 minutes**. We recommend you record a **brief greeting message** (see sample below) in order to leave more time in memory.

### To record a greeting message

- 1 Press **GREETING RECORD** to start the recording mode.
  - "Press RECORD again to record greeting." is heard.
- 2 Within 5 seconds, press **GREETING RECORD** again to record your greeting.
  - A long beep sounds.
- 3 After the long beep, speak clearly about 8 inches (20 cm) away from the **MIC** (microphone).
  - The base unit display shows the elapsed recording time.
- 4 When finished, press **STOP**.
  - To check the recorded greeting, press **GREETING CHECK**.
  - To change the message, repeat from step 1.

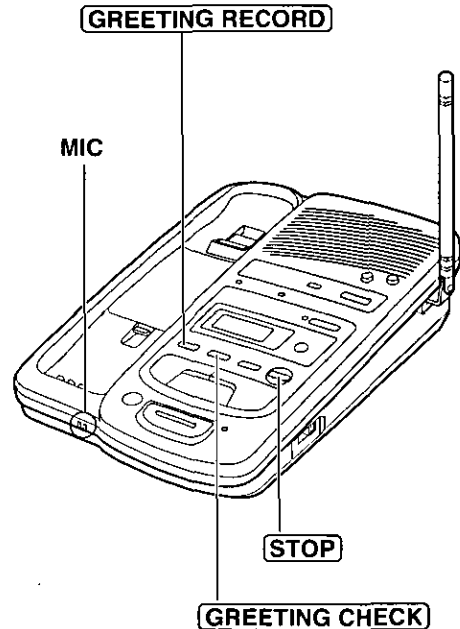

### Greeting message sample

"Hello, this is (your name and/or number). Sorry I cannot take your call. Please leave a message after the beep. Thank you."



## To erase the recorded greeting message

Press **GREETING CHECK** ➡ press **ERASE** while the message is being played.

- The unit will answer a call with a pre-recorded greeting.

## Pre-recorded greeting message

If you do not record a personal greeting message (p. 20), one of the following two messages will be played when a call is received depending on the caller's recording time (p. 23).

**To check the pre-recorded greeting**, press **GREETING CHECK**.

- The pre-recorded greeting is played as below.
- When the recording time is set to "1 minute" or "unlimited";  
"Hello, we are not available now. Please leave your name and phone number after the beep. We will return your call."
- When the recording time is set to "greeting only";  
"Hello, we are not available now. Please call again. Thank you for your call."

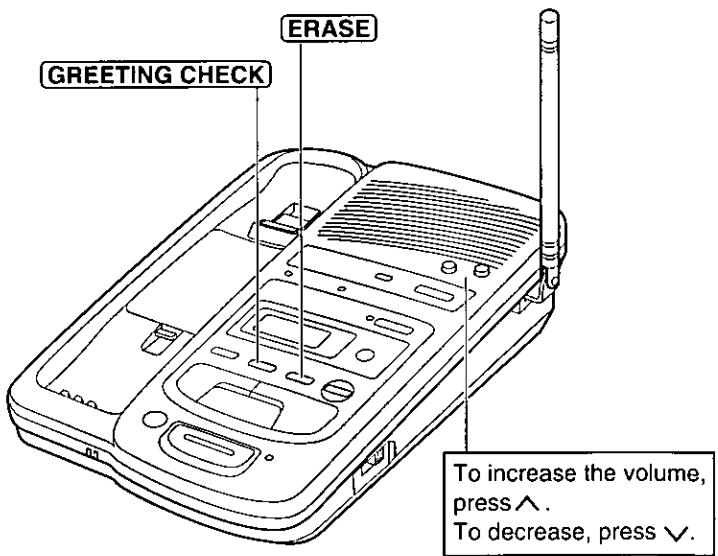

## ➔ Preparing the Answering System

---

### Summary of Programmable Preparations

You can program the following functions by using the handset near the base unit. See the bracketed pages for details.

The TALK/BATT LOW and DIGITAL SP-PHONE indicator lights must be off before programming.

Lift the handset, then press **PROGRAM**.



Press **SCREEN/PLAYBACK**.

- "ANSWERING SYSTEM SETTING" is displayed on the handset.



- If the handset displays "OUT OF RANGE" and an alarm tone sounds, move toward the base unit. Then try again.

To adjust **the time and day**, press **0**. (page 24)

To set **the remote code**, press **1**. (page 57)

To select **the number of rings**, press **2**. (page 26)

To set **the CPC function**, press **3**. (page 27)

To set **the greeting monitor function**, press **4**. (page 27)

To select **the caller's recording time**, press **5**. (page 23)

To store **the pager number**, press **#**. (page 54)

- The base unit display shows numbers or characters related to the adjustment or settings.



When finished, press **PROGRAM**.

- A confirmation tone sounds.\*

- To cancel, press **PROGRAM**, then start from the beginning.
- If 6 beeps sound during programming, you have pressed a wrong key. Enter the correct number again.

#### \*What the confirmation tone means

1 beep: The new programmed number is stored.

2 beeps: The number is the same as a previously stored one.

6 beeps: The number is not correct. Try again from the beginning.



## Selecting the Caller's Recording Time

You may select the caller's recording time as either "1 minute", "unlimited" or "greeting only". The factory preset is "unlimited".

- 1 Press **PROGRAM**.
  - The TALK/BATT LOW indicator flashes.
- 2 Press **SCREEN/PLAYBACK**.
  - The indicator lights.
  - "P" is displayed on the base unit.
- 3 Press **5**.
  - The current setting is displayed on the base unit.
    - 1: 1 minute
    - 2: unlimited (factory preset)
    - 3: greeting only
- 4 Press **1**, **2** or **3** to select the recording time.
  - The setting is displayed.
- 5 When finished, press **PROGRAM**.
  - The indicator lights go out.

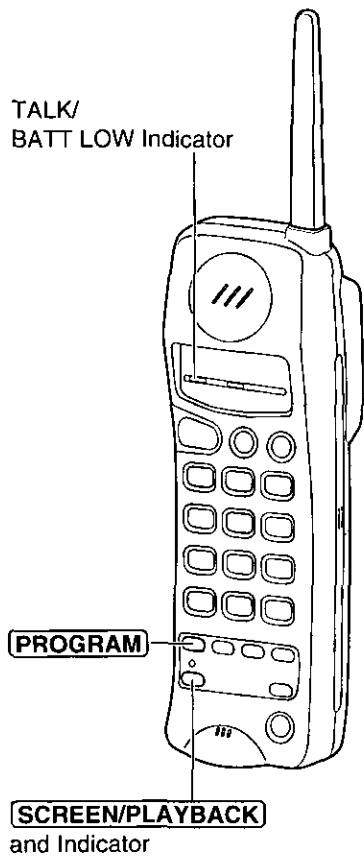

If you select "greeting only", the unit answers a call with the greeting message, then hangs up. The unit will not record any messages.

## ➔ Preparing the Answering System

### Time and Day Adjustment

**Voice Time/Day Stamp:** During playback a synthesized voice will announce the time and day when each message was recorded.

If you subscribe to a Caller ID service (p. 38), read the information on the next page.

- 1 Press **PROGRAM**.
  - The TALK/BATT LOW indicator flashes.
- 2 Press **SCREEN/PLAYBACK**.
  - The indicator lights.
  - "P" is displayed on the base unit.
- 3 Press **0**.
  - "⌚" is displayed on the base unit.
  - "Set time" is announced.
  - The time/day will be heard if it was adjusted beforehand.
- 4 Enter the current time (hour and minute) by using a 4-digit number. (Ex. To set 9:30, enter "0930".)
  - The entered number is displayed on the base unit.
- 5 Press **\*** to select "AM" or "PM".  
Press **#** repeatedly to set the day.
- 6 When finished, press **PROGRAM**.
  - The unit announces the time/day.
  - The clock starts working.

TALK/  
BATT LOW Indicator

**PROGRAM**

**SCREEN/PLAYBACK**  
and Indicator

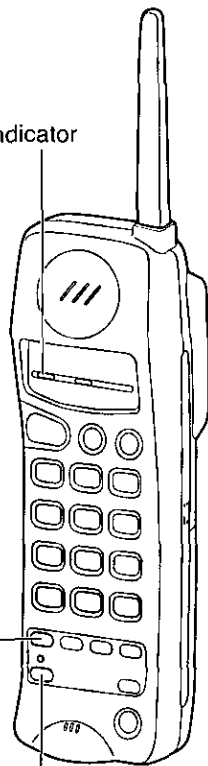

- In step 4, you cannot enter numbers greater than 12. (To set 13:00 hours, enter "0100" and select "PM" by pressing **\***.)
- The accuracy of the clock is approximately  $\pm 45$  seconds a month at room temperature.

If a power failure occurs, the adjusted time/day may be cleared.





## To check the time/day

Press **PROGRAM** → **SCREEN/PLAYBACK** → **0**.

- The current time/day is heard. When finished, press **PROGRAM**.

## For Caller ID service users (p. 38)

- The time will be adjusted by the incoming Caller ID information after the first ring. In this case, the day will not be adjusted. To adjust the day, follow steps 1 to 3 on page 24, press **#** repeatedly, then press **PROGRAM**.
- The Caller ID information will re-set the clock if the adjusted time is incorrect.
- The Caller ID information will automatically set the clock ahead at the beginning of winter and summer.

## ➔ Preparing the Answering System

### Selecting the Number of Rings

You may select the number of rings before the answering system answers a call, from "2" to "7" or "AUTO (for Toll Saver)". The factory preset is "AUTO".

- 1 Press **PROGRAM**.
  - The TALK/BATT LOW indicator flashes.
- 2 Press **SCREEN/PLAYBACK**.
  - The indicator lights.
  - "P" is displayed on the base unit.
- 3 Press **2**.
  - The current setting is displayed on the base unit.
- 4 Press dialing button **0**, or **2** to **7** to set the number of rings.
  - 0**: Selects "AUTO".  
"A" is displayed.
  - 2-7**: The unit will answer on the selected number of rings.
- 5 When finished, press **PROGRAM**.
  - The indicator lights go out.

TALK/  
BATT LOW Indicator

**PROGRAM**

**SCREEN/PLAYBACK**  
and Indicator

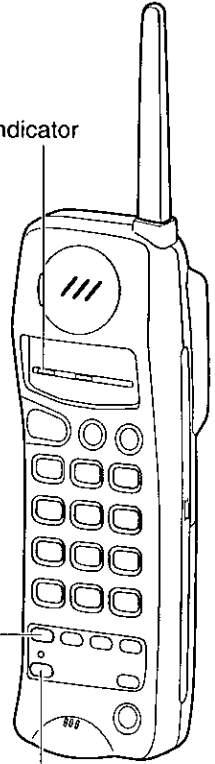

#### Toll Saver (When set to "AUTO")

When you call the unit from a touch tone telephone:

If the unit answers on the 2nd ring, there is at least one new message.

If the unit answers on the 4th ring, there are no new messages.

**Hang up when you hear the 3rd ring.** This will save you the toll charge for the call.

## Setting the CPC (Calling Party Control) Function

The CPC function is preset to "A". If you use a call waiting service, set to "b", or the call waiting tone will disconnect someone leaving a message.

1. Press **PROGRAM**.
2. Press **SCREEN/PLAYBACK**.
3. Press **3**.
  - The current setting "A" or "b" is displayed on the base unit.
4. To select "b", press **2**.  
OR  
To select "A", press **1**.
  - The setting is displayed.
5. When finished, press **PROGRAM**.

## Setting the Greeting Monitor Function

When your greeting message is being played to the caller, you can also listen to it through the speaker. To listen to your greeting, set to "2 (ON)". The factory preset is "1 (OFF)".

1. Press **PROGRAM**.
2. Press **SCREEN/PLAYBACK**.
3. Press **4**.
  - The current setting "1" or "2" is displayed on the base unit.
4. To set to "2 (ON)", press **2**.  
OR  
To set to "1 (OFF)", press **1**.
  - The setting is displayed.
5. When finished, press **PROGRAM**.

# Making Calls

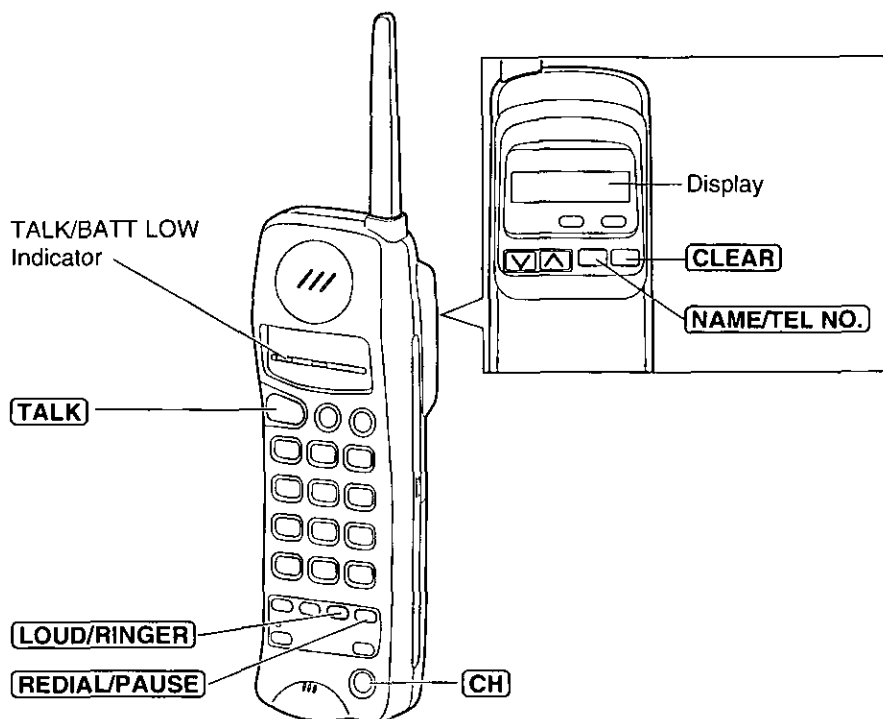

- 1** Press **TALK**.
- The TALK/BATT LOW indicator lights.

TALK	CH10
------	------

- 2** Dial a phone number.
- The dialed number is displayed.
  - After a few seconds, the display will show the length of the call.

1112222	CH10
---------	------

00-00-00	CH10
----------	------

- 3** To hang up, press **TALK** or place the handset on the base unit.
- The TALK/BATT LOW indicator light goes out.

## To redial the last number dialed

Press **TALK** ➔ **REDIAL/PAUSE**.

- If "OUT OF RANGE" is displayed and an alarm tone sounds after pressing **TALK** when making a call, move closer to the base unit or place the handset on the base unit. Then try again.
- To display the dialed number during a conversation, press **NAME/TEL NO.**. To return to the length of the call, press **CLEAR**.

## To select the receiver volume

Press **LOUD/RINGER** while talking.

- Each time you press the button, the volume level will change from MEDIUM (preset) to HIGH to LOW.

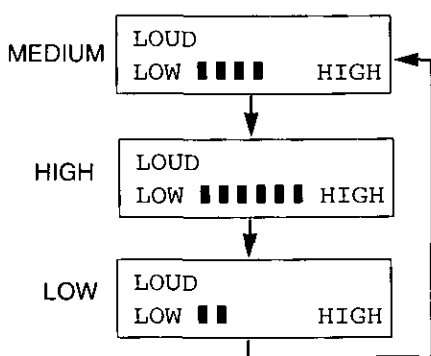

## If noise interferes with the conversation

Press **CH** to select a clearer channel or move closer to the base unit.

- The selected channel number is displayed.

## Lighted keypad (KX-TCC942-B only)

The dialing buttons will light while dialing and flash when a call is received. The lights will go out about 10 seconds after dialing or answering a call.

## Lighted display

The display will light when the handset is in use (making/answering a call, viewing the caller list, etc.). The light will go out about 10 seconds after pressing a handset button or answering a call.

# Answering Calls

---

## With the Handset

If you subscribe to a Caller ID service, the calling party information will be displayed on the handset after the first ring (p. 38).

If the handset is off the base unit, press **TALK**.

- You can also answer a call by pressing any dialing button 0 to 9, \*, or # (— **Any Key Talk**).

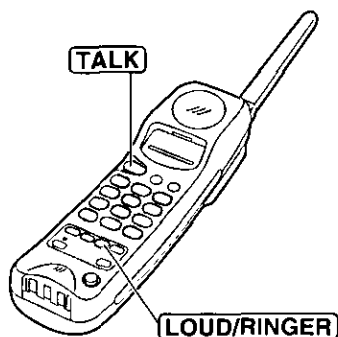

**OR**

If on the base unit, just lift it up.  
(This is not available when the Auto Talk feature is set to OFF. See page 19.)

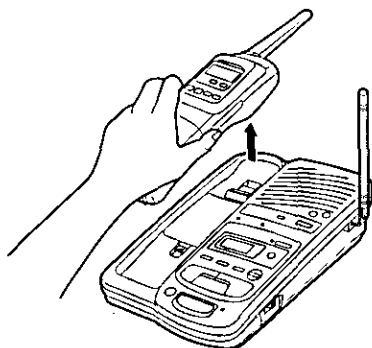



## Adjusting the handset ringer volume

The TALK/BATT LOW indicator light must be off.

- To select **HIGH (preset) or LOW**, press **LOUD/RINGER** lightly. (Each time you press the button lightly, the ringer volume will change.)

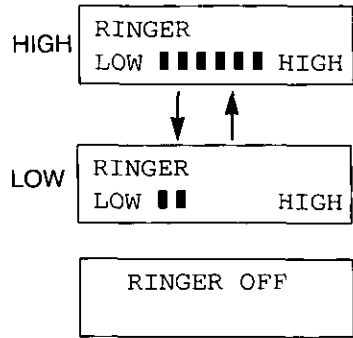

- To turn the ringer **OFF**, press **LOUD/RINGER** until 2 beeps sound.

"RINGER OFF" will be displayed for about 1 minute before the handset returns to the stand-by mode.

- To turn the ringer **ON**, press **LOUD/RINGER** lightly. The ringer sounds at the HIGH level.

## Selecting the ringer tone (2 types)

The TALK/BATT LOW indicator light must be off.

1. Press **LOUD/RINGER**.
2. Press **\*** within 5 seconds.
  - The selected ringer tone sounds.
  - Each time you press **\*** within 5 seconds, the ringer tone will change.

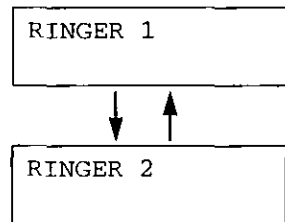

## ➔ Answering Calls

### With the Base Unit (Digital Duplex Speakerphone)

When a call is received, the unit rings and the CALLER ID indicator light flashes quickly.

1 Press **DIGITAL SP-PHONE**.

- The indicator lights.

2 Speak into the **MIC** (microphone).

3 To hang up, press **DIGITAL SP-PHONE**.

- The indicator light goes out.

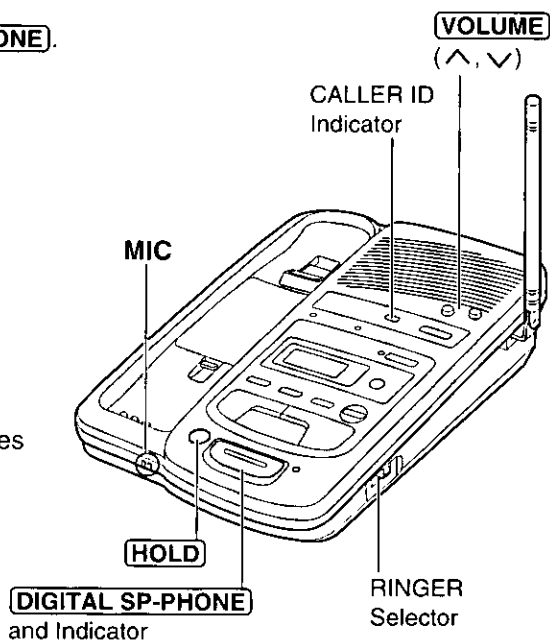

- While using the speakerphone, if the handset is on the base unit, you may switch to the handset by lifting it up.
- The DIGITAL SP-PHONE button is designed only for answering calls. If you press it to make a call, a dial tone may not be heard. This is normal.

### To adjust the speaker volume (8 levels)

To increase, press **VOLUME**  $\wedge$  . To decrease, press **VOLUME**  $\vee$  .



## Hands-Free Digital Duplex Speakerphone

The digital duplex speakerphone enhances your telephone conversation. For best performance, please note the following:

- Use the speakerphone in a quiet room.
- Speak alternately with the caller.
- If the caller complains that your voice is hard to hear, press **VOLUME** √ to decrease the speaker volume.
- If the other party's voice from the speaker cuts in/out during a conversation, press **VOLUME** √ to decrease the speaker volume.

## To put a call on hold

Press **HOLD**.

- The DIGITAL SP-PHONE indicator flashes.
- After 6 minutes, a warning tone will sound.  
After a total of 10 minutes, the call will be disconnected.

## To release the hold

For the base unit, press **DIGITAL SP-PHONE**.

For the handset, press **TALK** or lift the handset off the base unit.

- If another phone is connected on the same line (p. 67), you can also release the hold by lifting that handset.

## To select the base unit ringer volume

Set the RINGER selector to HIGH, LOW, or OFF.

- When set to OFF, the base unit will not ring.

# Automatic Dialing

## Storing Phone Numbers in Memory

You can store up to 10 phone numbers in the handset. The dialing buttons (0 to 9) function as memory stations.

**The TALK/BATT LOW indicator light must be off before programming.**

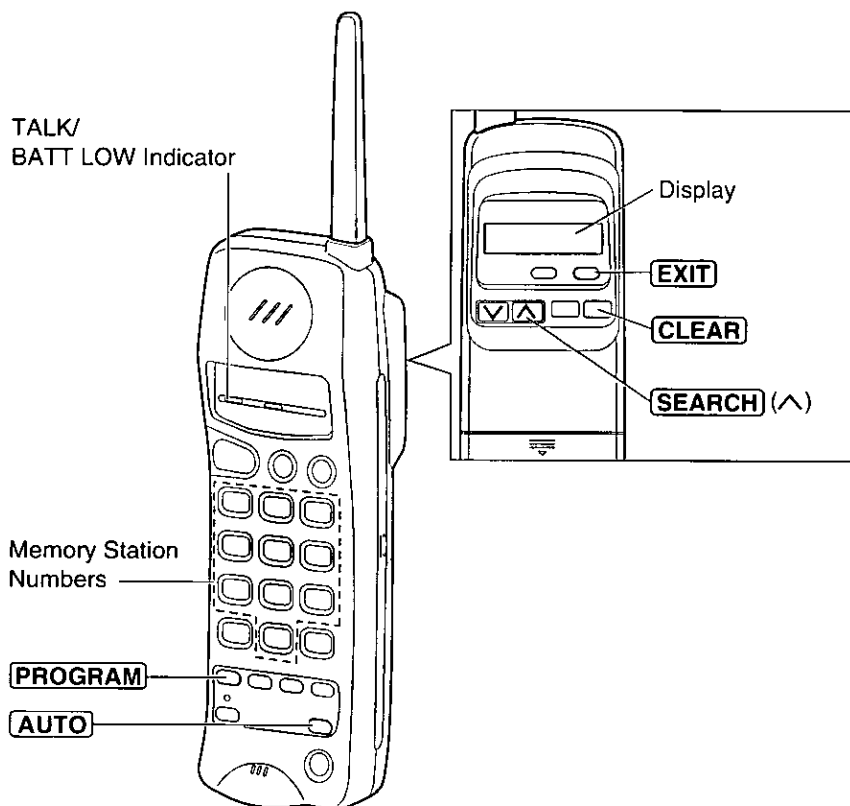



- 1 Press **PROGRAM**.
- The TALK/BATT LOW indicator flashes.

SAVE AUTO# ?  
V=NEXT    ^=YES

- 2 Press **SEARCH** ^ (YES key).

ENTER PHONE NO.

- 3 Enter a phone number up to 16 digits.
- If you misdial, press **CLEAR**. Digits are corrected from the right.

3334444  
AUTO=SAVE

- 4 Press **AUTO**.

SELECT 0-9  
TO SAVE IN AUTO

- 5 Press a memory station number (0 to 9).
- A confirmation tone sounds.\*
  - In a few seconds, the handset will return to the stand-by mode.
  - To store other numbers, repeat steps 1 through 5.

3334444  
SAVE IN AUTO 1

- To cancel, press **PROGRAM** or **EXIT**, then start from step 1.

### \*What the confirmation tone means

- 1 beep: The new number is stored.  
2 beeps: The number is the same as a previously stored one.

## ➔ Automatic Dialing

### Memory sticker

Use the included memory sticker as a name or phone number index for automatic dialing. Attach the sticker to the unit or in a convenient place.

10-STATION AUTOMATIC DIALER	
1	6
2	7
3	8
4	9
5	0
TEL NO.	

### To erase a stored number

- 1 Press **PROGRAM**.
  - The TALK/BATT LOW indicator flashes.
- 2 Press **SEARCH** ^ (YES key).
- 3 Press **CLEAR**.
- 4 Press **AUTO**.
- 5 Press the memory station number (0 to 9) of the phone number to be erased.

SAVE AUTO# ?  
v=NEXT     ^=YES

ENTER PHONE NO.

AUTO=CLEAR

SELECT 0-9 TO  
CLEAR IN AUTO

CLEAR IN AUTO 1

---

## Dialing a Stored Number

- 1 Press **TALK**.
- 2 Press **AUTO**.
- 3 Press the memory station number (0 to 9).
  - The stored number is dialed.

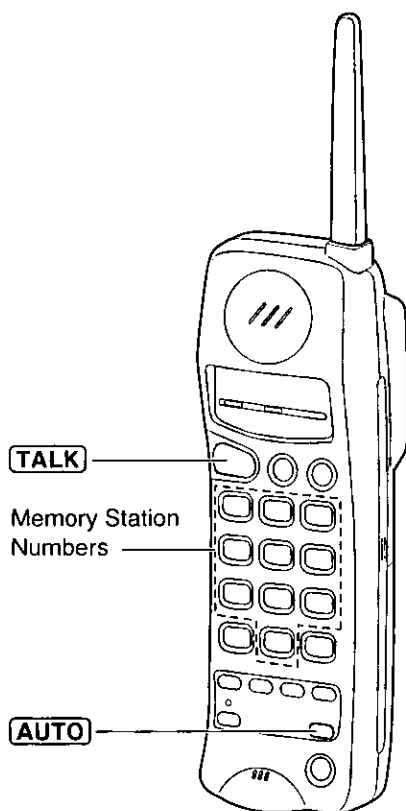

Cordless Telephone

# Caller ID Service

This unit is compatible with a Caller ID service offered by your telephone company.

After you subscribe to a Caller ID service, the calling party information will be displayed on the handset after the first ring.

The unit records information of up to 30 callers, including the time and date received, and the number of times called, in the Caller List. The Caller List information is sorted by the most recent to oldest call.

Using the list, you can automatically dial the caller. You can store the caller's numbers in the Caller List into the automatic dialing memory.

If you subscribe to a Visual Call Waiting (Call Waiting ID) service, when a second call is received, the new caller's name and phone number will be displayed on the handset (p. 48).

## How caller information is displayed when a call is received

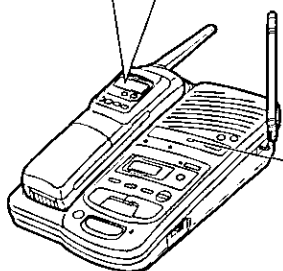
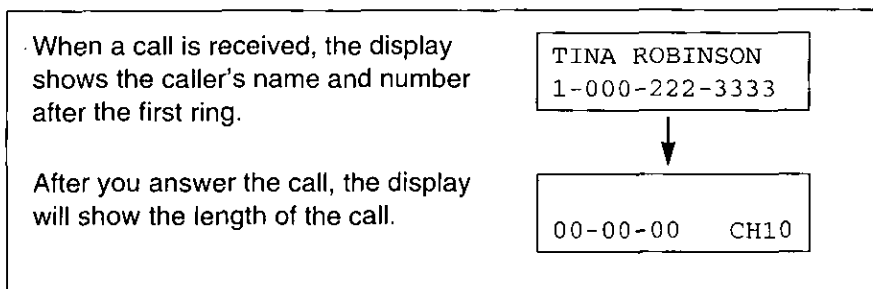

The CALLER ID indicator light flashes quickly when a call is received.

- In some cases, caller information cannot be displayed. In these cases, the handset display will show as follows.

The caller dialed from an area which does not provide the Caller ID service.

OUT OF AREA

The caller has requested not to display their information.

PRIVATE CALLER

- When the unit is connected to a PBX system, you cannot receive caller information.
- In some calling areas, the name display service may not be available. For further information, please contact your telephone company.

## To check the number of new calls

When new calls have been received, the CALLER ID indicator flashes slowly on the base unit.

### While the handset is on the base unit:

If you have received 10 new calls, the display will show the following.

10 NEW CALLS

When you lift the handset, the display changes to the following.

10 NEW CALLS  
 √=NEW      ∧=OLD

- After 10 seconds, the display changes to the stand-by mode (p. 15).

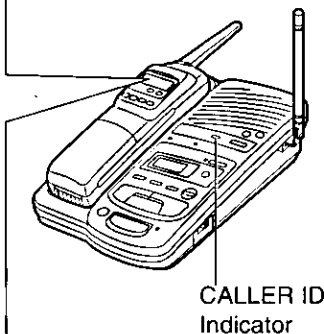

Cordless Telephone

### While the handset is off the base unit:

Press **SEARCH** (√ or ∧) to turn the display on. If you have received 10 new calls, the display will show the following.

10 NEW CALLS  
 √=NEW      ∧=OLD

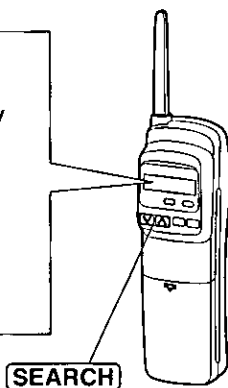

# Using the Caller List

## Viewing the Caller List

To confirm who has called you, follow the steps below.

- 1** Lift the handset off the base unit.  
OR

When the handset is off the base unit, press **SEARCH** (∨ or ∧) to enter the list.

- The display will show the following.

1 NEW CALL
∨=NEW      ∧=OLD

- 2** To search from the most recent call, press **SEARCH** ∨ (NEW key).  
To search from the oldest call, press **SEARCH** ∧ (OLD key).

- To move between callers, press **SEARCH** (∨ or ∧).
- To alternate the display between the name and number, press **NAME/TEL NO.**

- 3** To exit the list, press **EXIT**.

- The handset will return to the stand-by mode.

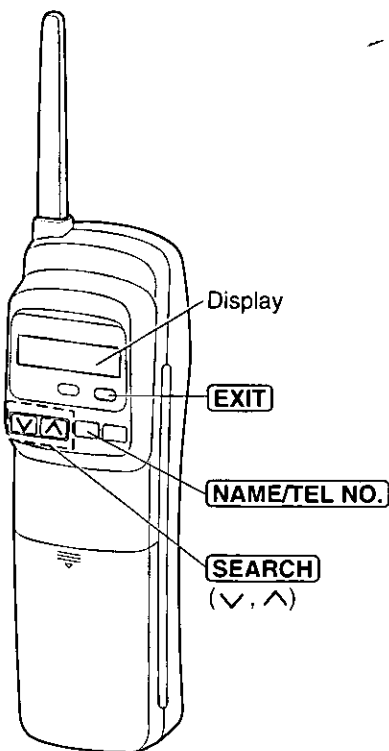

- Once NEW calls have been checked, they will be listed as OLD. The number of NEW calls will be displayed as "0 NEW CALL" after all of the NEW calls have been checked.
- When you answer a call or call back, the caller information will be listed as OLD.
- If "NO CALLERS" is displayed in step 1, the Caller List is empty. Press **EXIT** to exit the list.
- If more than one call is received from the same caller, the date and time of the last call will be recorded. Also, OLD call entries will be deleted when the same caller calls again.





## Ex. When you search from the most recent call:

1 NEW CALL

Lift the handset off the base unit.

OR

[Empty box]

When the handset is off the base unit, press **SEARCH** √.

1 NEW CALL  
√=NEW    ^=OLD

Press **SEARCH** √.

JACK SMITH  
11:20A JAN12 ×3

Press **NAME/TEL NO.**.

111-2222  
11:20A JAN12 ×3

Press **SEARCH** √.

Press **SEARCH** √.

END OF NEW CALL

Press **SEARCH** √.

• NANCY BROWN  
9:54A JAN10 ×2

Press **NAME/TEL NO.**.

• 222-3333  
9:54A JAN10 ×2

Press **SEARCH** √.

Press **SEARCH** √.

/ KEVIN PARKER  
8:35P JAN 9

Press **NAME/TEL NO.**.

/ 333-4444  
8:35P JAN 9

Press **SEARCH** √.

Press **SEARCH** √.

END

\*If the next caller does not have name information, the display will only show the phone number.

Press **SEARCH** √.

To exit the Caller List, press **EXIT**.

• The handset will return to the stand-by mode.

### Display Symbols

• : You have viewed this caller information at least once or answered the call.

/ : You have called back the caller.

×2-×9 : The number of times they called (up to 9).

## ➔ Using the Caller List

### Calling Back from the Caller List

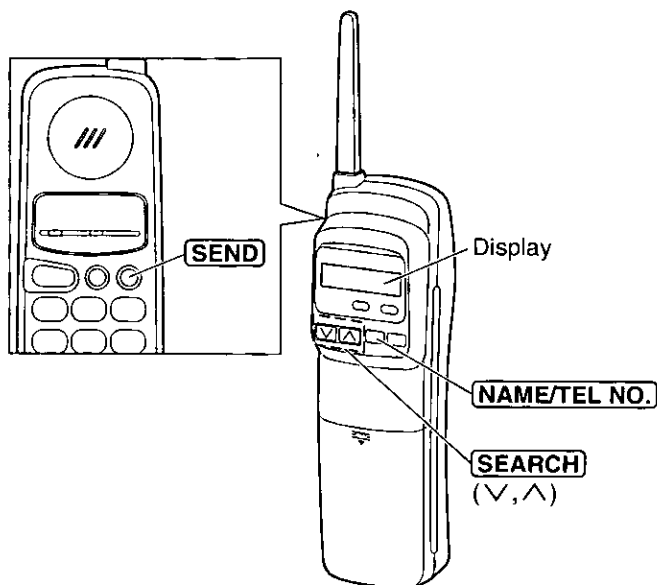

- 1** Lift the handset off the base unit.  
OR  
When the handset is off the base unit, press **SEARCH** (v or ^) to enter the list.

3 NEW CALLS	
v=NEW	^=OLD

- 2** Press **SEARCH** (v or ^) repeatedly to find the desired caller.
- To confirm the caller's phone number, press **NAME/TEL NO.**.

CINDY TURNER
11:20A JAN12 X3

- 3** Press **SEND**.
- The unit obtains a dial tone and automatically dials the displayed phone number.

1-234-456-7890
CH11

- In some cases you may have to edit the number before it is dialed (p. 43). (Ex. You may have to add "1" for long distance calls.)  
If the area code is not stored (p. 18), the edited number will not be saved in the Caller List.
- If a phone number is not displayed in the caller information, you cannot call back that caller.



## Editing the Caller's Phone Number

The unit can edit a phone number into one of 4 patterns.

- 1** Lift the handset off the base unit.  
OR  
When the handset is off the base unit, press **SEARCH** (∨ or ^) to enter the list.

5 NEW CALLS
∨=NEW      ^=OLD

- 2** Press **SEARCH** (∨ or ^) repeatedly to find the desired caller.

FRED PARKER
11:20A JAN12 ×3

- 3** Press **NAME/TEL NO.** to display the caller's phone number.

321-5555
11:20A JAN12 ×3

- 4** Press **EDIT** to select an edit pattern. Each time you press **EDIT**, the number is rearranged into one of 4 different patterns.

- (a) 1 - Phone no.
- (b) 1 - Area code - Phone no.
- (c) Area code - Phone no.
- (d) Phone no.

- The cursor on the area code will flash. You can change the area code by entering the correct number using the dialing buttons.
- The order in which patterns (a) - (d) are displayed depends on which pattern the telephone number is displayed in step 3.

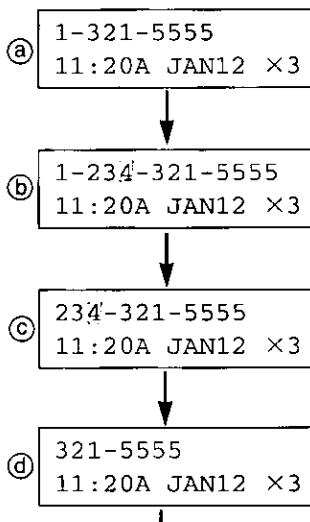

Cordless Telephone

- 5** After you edit the number into the desired pattern, you can continue with storing or call back procedures.  
To store the number in automatic dialing memory, press **AUTO**. Then press a memory station number (0 to 9) (p. 44).  
To call back, press **SEND** (p. 42).

## ➔ Using the Caller List

---

### Storing the Caller List Information in Automatic Dialing Memory

You can store numbers that are in the Caller List into the automatic dialing memory.

The TALK/BATT LOW indicator light must be off.

- 1 Lift the handset off the base unit.  
OR  
When the handset is off the base unit, press **SEARCH** (∨ or ∧) to enter the list.

```
10 NEW CALLS
∨=NEW      ∧=OLD
```

- 2 Press **SEARCH** (∨ or ∧) repeatedly to find the caller you want to store in memory.
  - To check the phone number, press **NAME/TEL NO.**. If the number requires editing, see page 43.

```
CINDY TURNER
11:20A JAN12 ×3
```

- 3 Press **AUTO**.

```
SELECT 0-9
TO SAVE IN AUTO
```

- 4 Press a memory station number (0 to 9).
  - A confirmation tone sounds (p. 35).

```
1-234-456-7890
SAVE IN AUTO 0
```

- You cannot store caller information in automatic dialing memory when a phone number is not displayed.

## Erasing the Caller List Information

After checking the Caller List, you can erase some or all of the entries.

### To erase a specific caller from the Caller List

- 1** Lift the handset off the base unit.  
OR  
When the handset is off the base unit, press **SEARCH** (∨ or ∧) to enter the list.

10 NEW CALLS  
∨=NEW      ∧=OLD

- 2** Press **SEARCH** (∨ or ∧) repeatedly to find the caller you want to erase from memory.

TOM REAGAN  
12:20A JAN12 ×3

- 3** Press **CLEAR**.
- The information is erased.
  - In a few seconds, the display shows the previous caller information.

CLEAR

### To erase all entries in the Caller List

- 1** Lift the handset off the base unit.  
OR  
When the handset is off the base unit, press **SEARCH** (∨ or ∧) to enter the list.

Be sure this display is shown.

0 NEW CALL  
∨=NEW      ∧=OLD

- 2** Press **CLEAR**.

PRESS CLEAR FOR  
ALL CLEAR

- 3** Press **CLEAR** again.
- All of the entries are erased.
  - In a few seconds, the handset will return to the stand-by mode.

ALL CLEAR

- You can also erase all of the entries by setting the display to "END OF NEW CALL", "END OF OLD CALL" or "END" using **SEARCH** (∨ or ∧) in step 1.

# Intercom

A 2-way intercom is available between the handset and the base unit.

## Paging the base unit from the handset

**1** Handset:  
Press **INTERCOM**, then speak.

- The indicator lights and "INTERCOM" is displayed.

**2** Base unit:  
When the other party's voice is heard, answer using the **MIC**.

**3** Handset:  
To end the intercom, press **INTERCOM**.

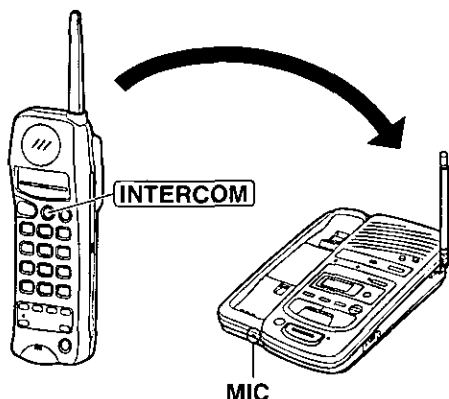

## Paging the handset from the base unit (Handset locator)

Using this feature, you can locate the handset if misplaced.

**1** Base unit:  
Press **LOCATOR/INTERCOM**.

- The handset beeps for 1 minute and "PAGING" is displayed.
- To stop paging, press **LOCATOR/INTERCOM** again.

**2** Handset:  
Press **INTERCOM** to answer.

- "INTERCOM" is displayed.

**3** Base unit:  
Speak into the **MIC**.

**4** Handset:  
To end the intercom, press **INTERCOM**.

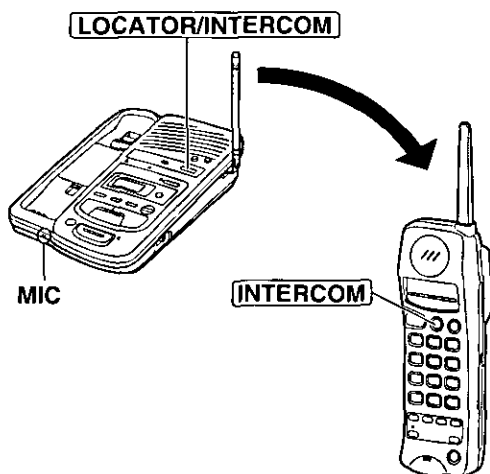

**During the intercom:**

- Intercom calls can only be ended by the handset.
- If two tones sound, an incoming call has been received. To answer, press **TALK** or **DIGITAL SP-PHONE**. The intercom is ended.

## Transferring a Call Using the Intercom

The intercom can be used during a call. This feature enables you to transfer a call between the handset and the base unit.

### From the handset to the base unit

- 1 Handset:**  
During a call, press **INTERCOM** then speak.
  - The call is put on hold and "INTERCOM HOLD" is displayed.
  - If the base unit is not answered, press **TALK**.
- 2 Base unit:**  
When the paging party's voice is heard, answer using the **MIC**.
- 3 Base unit:**  
To answer the call, press **DIGITAL SP-PHONE**.
  - The transfer is completed.
  - The handset user can join the conversation by pressing **TALK**.

### From the base unit to the handset

- 1 Base unit:**  
During a call, press **LOCATOR/INTERCOM**.
  - The call is put on hold.
  - If the handset is not answered, press **DIGITAL SP-PHONE**.
- 2 Handset:**  
Press **INTERCOM** to answer the page.
- 3 Handset:**  
To answer the call, press **TALK**.
  - The transfer is completed.
  - The base unit user can join the conversation by pressing **DIGITAL SP-PHONE**.

# Special Features

---

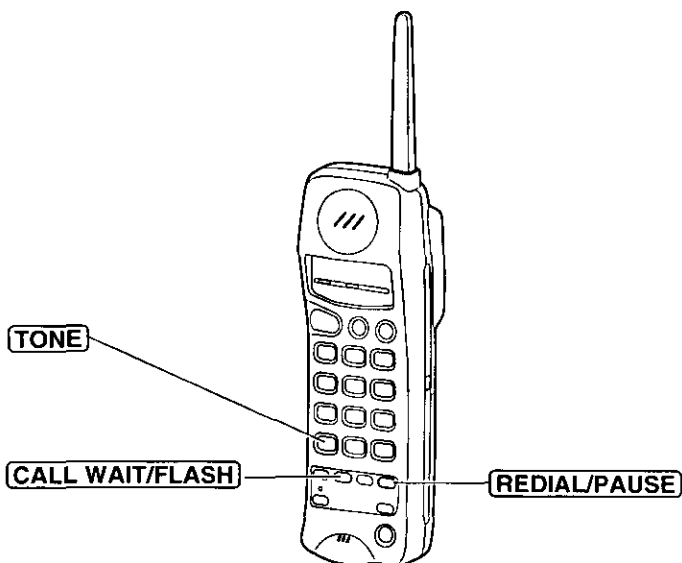

## For Call Waiting Service Users

Press **CALL WAIT/FLASH** if you hear a call-waiting tone while talking.

- The first call is put on hold and you can answer the second call.
- To return to the first caller, press **CALL WAIT/FLASH** again.

## Visual Call Waiting (Call Waiting ID) Service

Visual Call Waiting (Call Waiting ID) Service allows your handset to display the second caller's information. After you hear a call-waiting tone while talking, the handset will display the caller's name with the phone number and "----WAITING----" alternately.

- If the handset is off the base unit, the second caller's information will not be displayed when:
  - you are having a conversation with the base unit, or
  - the answering system is recording someone's message.
- Please contact your telephone company for details and availability in your area.



---

## Automatic Security Code Setting

Whenever you place the handset on the base unit, the unit automatically selects one of a million security codes. These codes help prevent the unauthorized use of your telephone line by another cordless telephone.

## Temporary Tone Dialing (For Rotary Pulse Service Users)

Press **[TONE]** before entering access numbers which require tone dialing.

- The dialing mode changes to tone. You can enter numbers to access an answering service, electronic banking services, etc. When you hang up, the mode returns to pulse.

## If Your Unit is Connected to a PBX (Analog Only)

We recommend you press **[REDIAL/PAUSE]** between the access number for an outside line and the phone number.

- Pressing **[REDIAL/PAUSE]** once creates a 3.5 second pause. This prevents misdialing when you redial or dial a stored number. (**[REDIAL/PAUSE]** counts as one digit.)

# Automatic Answering Operation

When the unit answers a call, the unit plays back your greeting message and records the caller's message.

- The total recording time (including the greeting message) is **about 14 minutes**. If messages are recorded in noisy rooms, the time may be shortened up to 3 minutes.
- A maximum of 64 messages can be recorded.

## Setting the Unit to Answer Calls

Press **ANSWER ON** to turn on the answering system.

- The button lights.
- The unit will announce the remaining recording time if it is less than 5 minutes.
- If you hear "Memory full" and the button light flashes rapidly, erase some or all of the messages (p. 53).

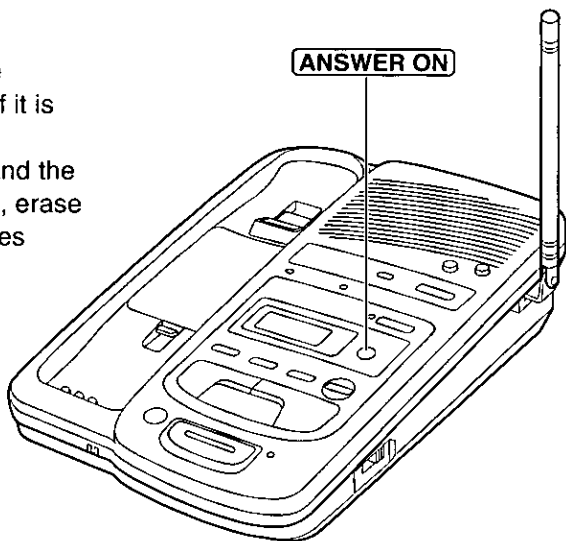

- If you do not want the unit to answer calls, press **ANSWER ON** to turn the answering system off. The button light goes out.
- You can also turn on the answering system remotely using any phone (p. 61).

## Monitoring incoming calls

While a call is being recorded, you can monitor it through the speaker. To answer the call with the speakerphone, press **DIGITAL SP-PHONE**. For the handset, lift the handset off the base unit or press **TALK**. The unit stops recording.

(To monitor incoming calls with the handset, see page 64.)

# Listening to Messages



You can see the total number of recorded messages on the base unit display. If the ANSWER ON button light flashes, new messages have been recorded.

## Listening to new messages only

Press **NEW MESSAGE** lightly.

- The unit announces the number of new messages and plays them back.

## Listening to all of the recorded messages

Press and hold **NEW MESSAGE** firmly until a short beep sounds.

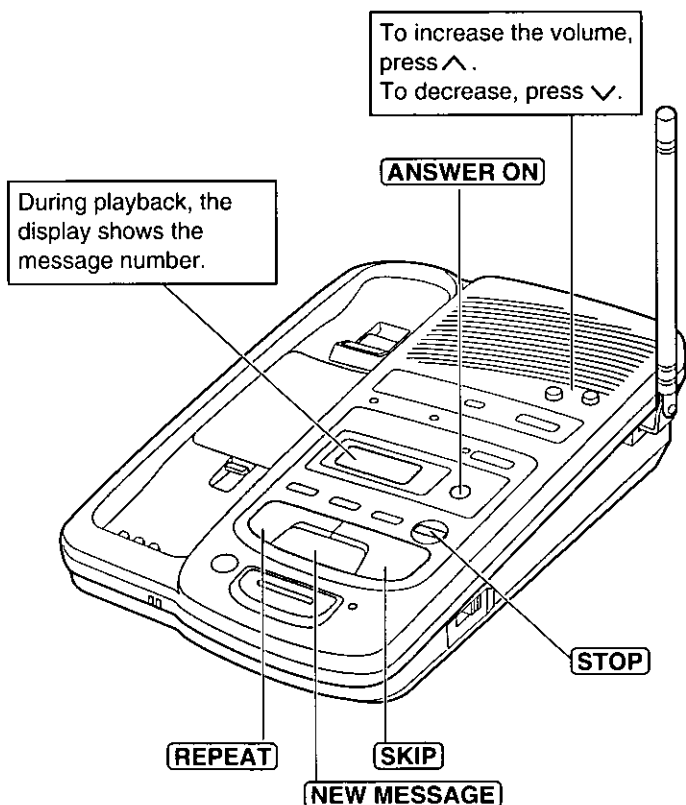

At the end of the last message, "End of final message" is heard. After the announcement, the unit will automatically turn the answering system back on.

## ➔ Listening to Messages

---

### During playback

To <b>repeat</b> the message	Press <b>REPEAT</b> . (If you press within 5 seconds of playback, the previous message will be played.)
To <b>skip</b> the message	Press <b>SKIP</b> . The next message is played.
To <b>stop</b> the operation	Press <b>STOP</b> . <ul style="list-style-type: none"><li>• To resume playback, press <b>NEW MESSAGE</b>.</li><li>• To turn on the answering system, press <b>ANSWER ON</b>.</li></ul>

### Flash Memory Message Backup

Messages are stored indefinitely on a “flash memory” IC chip — even if a power failure occurs. All of the messages are saved until you erase them.

#### **For Caller ID service users** (p. 38)

- When the handset is on the base unit, it will display the caller's name and/or number whose message is being played.
- Even after you listen to the new incoming messages, the calls will remain as NEW in the Caller ID Caller List until you check them (p. 40).

# Erasing Messages

The unit will announce the remaining recording time after playback if it is less than 5 minutes. New messages cannot be recorded when:

- “Memory full” is heard.
- “**FULL**” is displayed on the base unit.
- the ANSWER ON button light flashes rapidly.

Erase some or all of the messages. We recommend you erase unnecessary messages after each playback.

## Erasing a specific message

Press **ERASE** while the message you want to erase is being played.

- The unit erases the message.
- A series of beeps will sound and the unit continues to play the next message.

## Erasing all of the messages

All of the recorded messages except the greeting message can be erased at one time.

- 1 Press **ERASE**.
  - “Press ERASE again to erase all messages.” is heard.

- 2 Within 5 seconds, press **ERASE** again.
  - A series of beeps and “No message” are heard. The base unit display shows “0”.

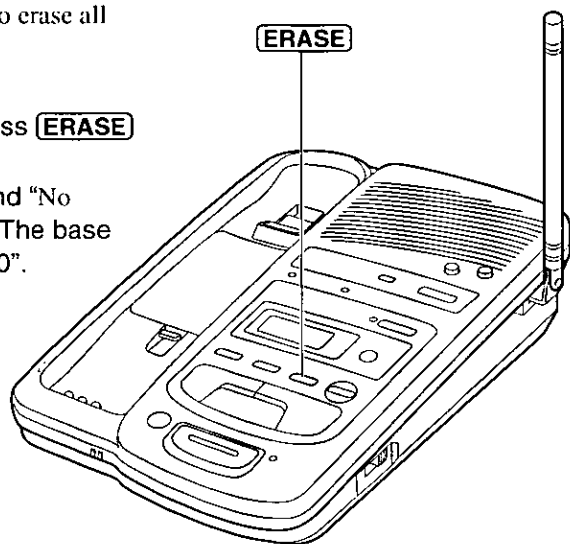

- The information in the caller list will not be erased.  
To erase the caller list information, see page 45.

# Pager Call

This feature allows you to alert your pager when the unit records an incoming message. You can retrieve the message from a touch tone telephone (p. 56). First store the pager number, then turn on the pager call mode.

The TALK/BATT LOW and DIGITAL SP-PHONE indicator lights must be off before programming.

## Storing the Pager Number

- 1 Press **PROGRAM**.
  - The TALK/BATT LOW indicator flashes.
- 2 Press **SCREEN/PLAYBACK**.
  - The indicator lights.
  - "P" is displayed on the base unit.
- 3 Press **#**.
- 4
  - a) Enter your pager number. (If necessary, press **REDIAL/PAUSE** twice.\*)
  - b) Enter the call back number to be displayed on the pager. (Press **#** if required by your pager company.)
    - If you misdial, press **PROGRAM** then start from step 1.
    - You can enter up to 48 digits total.
- 5 When finished, press **PROGRAM**.
  - The indicator lights go out.

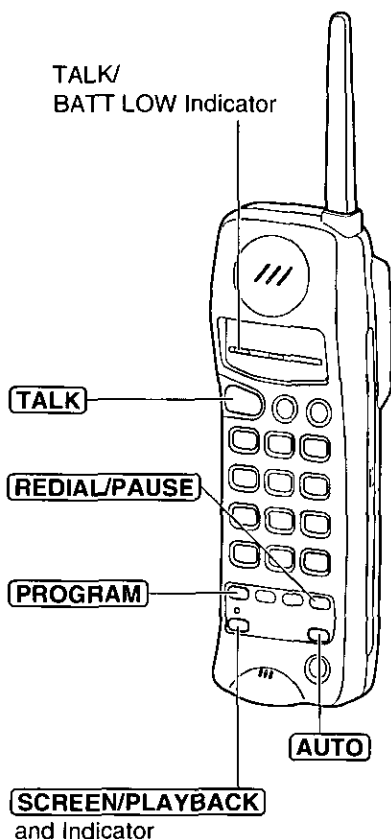

\* Your pager company may require a delay after the pager number is dialed. Contact your pager company regarding the required pause time. Pressing **REDIAL/PAUSE** once creates a 3.5 second delay and counts as one digit.

---

## To confirm the stored pager number

Press **TALK** → **AUTO** → **#**.

- The unit dials the stored number.
- If the pager does not beep, restart from step 1 to store the number again.

## To erase the stored pager number

Press **PROGRAM** → **SCREEN/PLAYBACK** → **#** → **PROGRAM**.

## Setting the Unit to Call the Pager

Press **PAGER CALL** to turn on the pager call mode.

- The indicator lights.
- If 6 beeps sound, the pager number is not stored. Store the number, then try again.

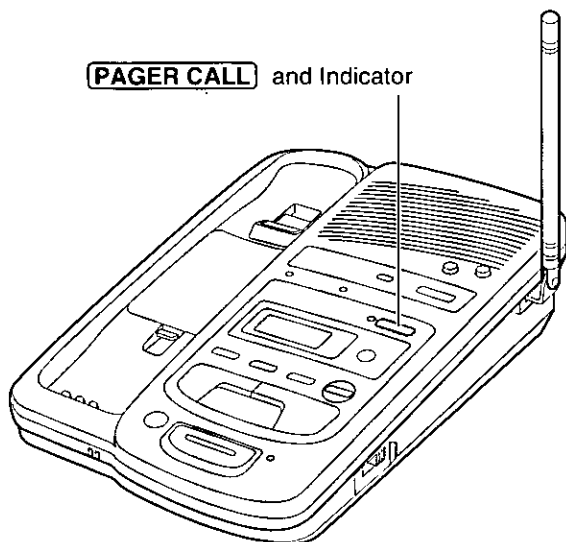

## To turn off the pager call mode

Press **PAGER CALL** again.

- The indicator light goes out.

# Remote Operation from a Touch Tone Phone

You can operate the answering system from any touch tone phone. A synthesized voice menu will guide you on how to operate the unit (p. 58).

- To skip the voice menu and operate the unit directly, see page 60.

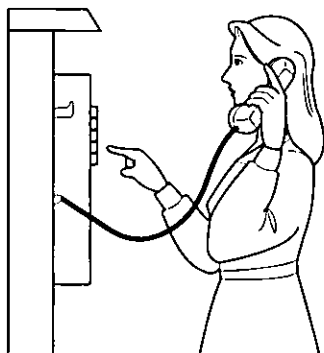

## Summary of the remote operation

Call your unit from a touch tone phone.

During/after the greeting message playback, enter your remote code (p. 57).

- The number of new messages is heard.

After 3 seconds, the voice menu starts (p. 58).

Follow the menu or enter the direct remote commands (p. 60).

To end the remote operation, hang up.

- You will not lose any messages when you hang up.





## Setting the Remote Code

The remote code prevents unauthorized people from accessing your unit and listening to your messages. Choose any **2-digit number (00-99)**.

The factory preset is "11".

**The TALK/BATT LOW and DIGITAL SP-PHONE indicator lights must be off before programming.**

- 1 Press **PROGRAM**.
  - The TALK/BATT LOW indicator flashes.
- 2 Press **SCREEN/PLAYBACK**.
  - The indicator lights.
  - "P" is displayed on the base unit.
- 3 Press **1**.
  - The current remote code is displayed on the base unit.
- 4 Enter a remote code by using a **2-digit number (00-99)**.
  - The entered number is displayed on the base unit.
- 5 When finished, press **PROGRAM**.
  - The indicator lights go out.

TALK/  
BATT LOW Indicator

**PROGRAM**

**SCREEN/PLAYBACK**  
and Indicator

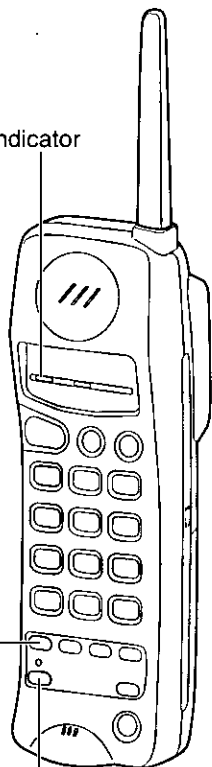

Answering System

- If 6 beeps sound in step 5, you entered a one digit number. Restart from step 1 to program a 2-digit number.
- If you want to use a single number remote code, enter "0" first, then the number.

### To check the remote code

Press **PROGRAM** ⇒ **SCREEN/PLAYBACK** ⇒ **1**.

The current remote code is displayed on the base unit.

When finished, press **PROGRAM**.

## ➔ Remote Operation from a Touch Tone Phone

### Voice Menu

The shaded boxes are voice prompts.

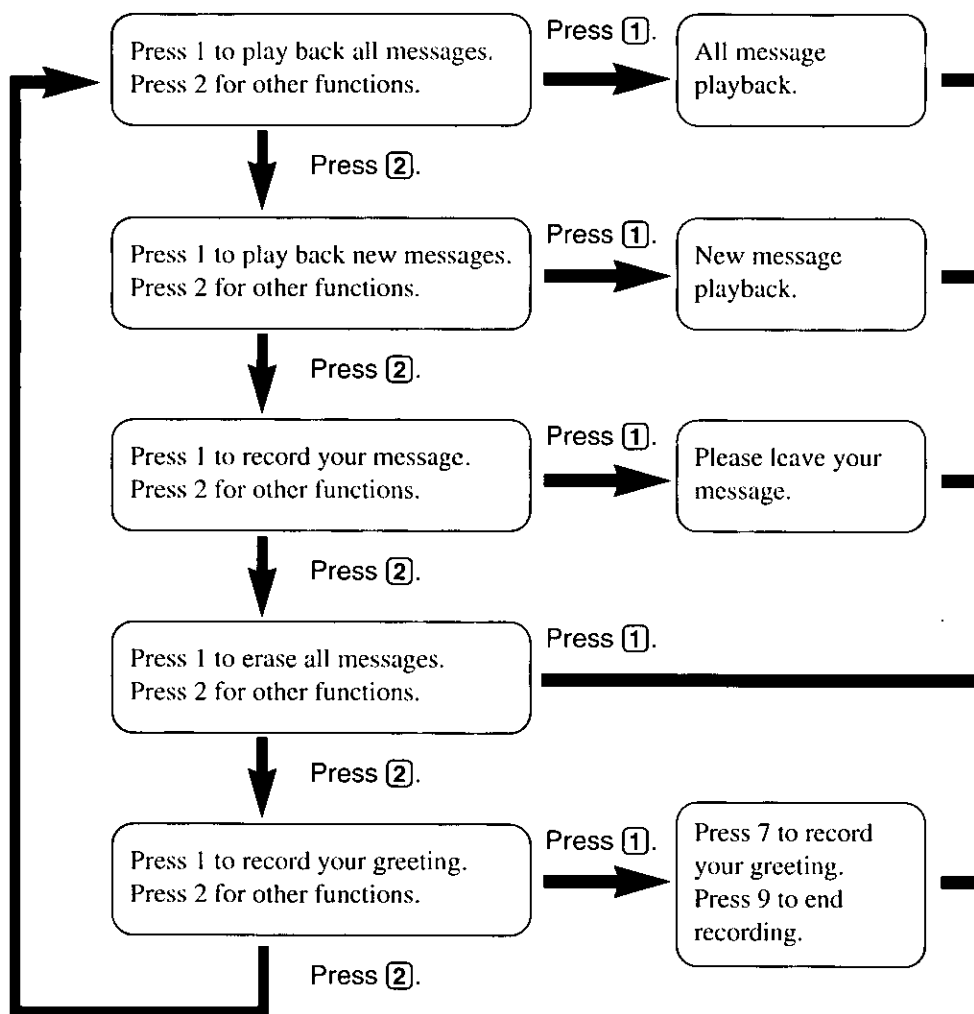



### All Message Playback

The unit plays back all of the recorded messages. At the end of the last message, "End of final message" and the remaining recording time are announced.



### New Message Playback

The unit plays back messages which have not been played yet.



### Recording a Memo Message

You can leave a personal message.

1. Speak after you hear "Please leave your message."
2. When you finish recording, hang up.



### Erase All Messages

All of the recorded messages (except the greeting message) are erased.



### Recording a Greeting Message

You can re-record your greeting message.

1. Press **[7]**.  
You hear a voice prompt followed by a long beep.
2. Speak after the long beep.
3. When you finish recording, press **[9]**.
4. Your greeting will be played back for confirmation.

- 3 seconds after playback, the voice menu will repeat from the beginning.
- If you hear "Memory full" after playback, erase some or all of the messages (p. 53).

## ➔ Remote Operation from a Touch Tone Phone

### Direct Remote Operation

Once you have entered the remote code, you can also control your unit by direct remote commands instead of using the voice menu. To end the remote operation, hang up anytime.

#### Direct commands

NEW MESSAGE  
PLAYBACK

4

- Only new messages are played back.

ALL MESSAGE  
PLAYBACK

5

- All of the messages are played back.

REPEAT  
(During playback)

1

- The current message is repeated.

SKIP  
(During playback)

2

- The current message is skipped.  
The next message is played.

STOP  
(During playback)

9

- Playback is stopped temporarily.
- To resume playback, press **9** again within 15 seconds or the voice menu will start.

GREETING  
MESSAGE  
RECORDING

7

- A long beep sounds.

↓  
RECORD

- Speak immediately after the long beep.

↓  
9

- Recording is stopped.
- The recorded message is played.

ERASING A  
SPECIFIC  
MESSAGE  
(During playback)

✖ 4

- The current message is erased.
- A series of beeps will sound and the next message is played.

ERASING ALL  
MESSAGES

✖ 5

- All of the recorded messages are erased.
- A series of beeps and "No message" are heard.

---

PAGER CALL  
ON/OFF

3

- Each time you press **3**, “on/off” is heard and the mode will turn on/off alternately.
- If you did not store a pager number, 6 beeps sound and the mode will not turn on.

---

ANSWERING  
SYSTEM OFF

0

- The unit hangs up and will not answer calls until turned on again.
- 

## Turning on the answering system

Call your unit and wait for 15 rings.

- The unit will answer and the greeting message is played.
- The answering system will turn on. Hang up or enter the remote code for other options.
- When turning on the answering system using a rotary pulse service telephone, you cannot enter a remote code for other options.

## Skipping the greeting message

After calling your unit, press **\*** during the greeting message playback.

- The unit skips the rest of the greeting and callers can start recording their message after the long beep.

# Remote Operation with the Handset

You can operate your answering system with the handset. The announcement and recorded messages can only be heard from the handset.

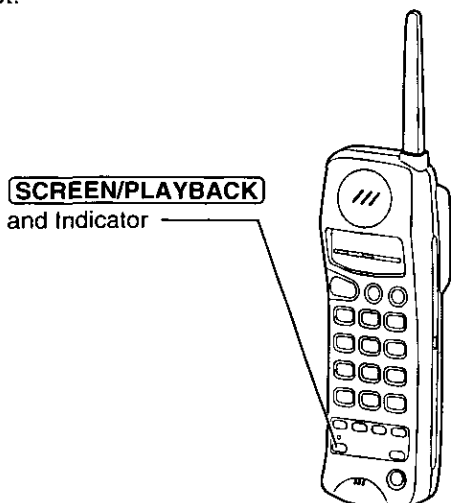

## Summary of the remote operation

Press **SCREEN/PLAYBACK**.

- The indicator lights.
- The number of new messages is heard.
- "REMOTE OPERATION" is displayed on the handset.

- ↓
- If the SCREEN/PLAYBACK indicator flashes, the answering system is off. To turn it on, press **8**.

Press the desired command buttons (see the following pages).

- If you do not press any command, the voice menu will start.\*
- After the voice menu, all message playback will start.

↓

To end the remote operation, press **SCREEN/PLAYBACK**.

- You will not lose any messages when you hang up.

- If you hear "Memory full" after playback, erase some or all of the messages (p. 53).
- When an incoming message has been recorded, 4 short beeps sound two times on the handset.



## \*Voice menu

If no commands are given after you press **SCREEN/PLAYBACK**, the unit will start the following voice menu:

“Press 4 to playback new messages; Press 5 to play back all messages.”

- You can enter direct commands even when the voice menu has started.

## Direct Commands

---

NEW MESSAGE PLAYBACK	<b>4</b>	• Only new messages are played back.
-------------------------	----------	--------------------------------------

---

ALL MESSAGE PLAYBACK	<b>5</b>	• All of the messages are played back.
-------------------------	----------	--

---

REPEAT (During playback)	<b>1</b>	• The current message is repeated.
-----------------------------	----------	------------------------------------

---

SKIP (During playback)	<b>2</b>	• The current message is skipped. The next message is played.
---------------------------	----------	--

---

STOP (During playback)	<b>9</b>	• Playback is stopped temporarily. • To resume playback, press <b>9</b> again within 15 seconds or the voice menu will start.
---------------------------	----------	--

---

ERASING A SPECIFIC MESSAGE (During playback)	<b>* 4</b>	• The current message is erased. • A series of beeps will sound and the next message is played.
---	------------	--

---

ERASING ALL MESSAGES	<b>* 5</b>	• All of the recorded messages are erased. • A series of beeps and “No message” are heard.
-------------------------	------------	---

## ➔ Remote Operation with the Handset

---

ANSWERING  
SYSTEM OFF

0

- The SCREEN/PLAYBACK indicator flashes.

ANSWERING  
SYSTEM ON

8

- The SCREEN/PLAYBACK indicator lights.
- 

### Monitoring incoming calls with the handset

When an incoming message is being recorded, the SCREEN/PLAYBACK indicator flashes slowly.

1. Press **SCREEN/PLAYBACK**.
  - The indicator lights and you can listen to the incoming call.
  - To answer the call, press **TALK**. The Any Key Talk feature (p. 30) is not available. The recording is ended.
2. When finished monitoring the call, press **SCREEN/PLAYBACK**.



# Remote Operation Card



## OPERATION WITH THE HANDSET

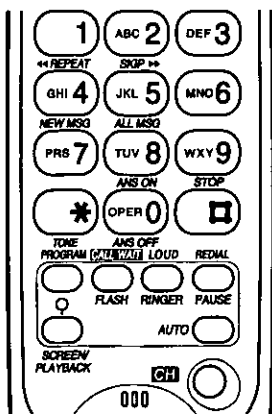

- If the SCREEN/PLAYBACK indicator flashes when you press SCREEN/PLAYBACK, the answering system is off. To turn it on, press [8].

Press **SCREEN/PLAYBACK**.



Press the desired command number as below.

- To play back new messages, press "4".
  - To play back all messages, press "5".
  - To repeat a message, press "1".
  - To skip a message, press "2".
- (For more functions, see the reverse side.)



To end the remote operation, press **SCREEN/PLAYBACK**.

## OPERATION FROM A TOUCH TONE PHONE

Call your unit.



Enter your remote code \_\_\_\_\_.



Press the desired direct command number as shown here.

OR

Wait for 3 seconds and the unit will start the voice menu. Follow the instructions. (See reverse side.)



To end the remote operation, hang up.

No.	Direct Commands
1	Repeat the message
2	Skip the message
3	Pager call on/off
4	New message playback
5	All message playback
7	Recording your greeting
9	Stop
0	Answer off
*	Greeting message skip
*4	Erasing a specific message
*5	Erasing all messages

- When you press a button, press firmly.

## ➔ Remote Operation Card

---

Press **SCREEN/PLAYBACK**.



- **To erase a specific message,** press “\*4” during the message playback.
- **To erase all messages,** press “\*5”.
- **To turn off the answering system,** press “0”.



To end the remote operation, press **SCREEN/PLAYBACK**.

- **To monitor incoming calls:**  
When the **SCREEN/PLAYBACK** indicator flashes slowly, press **SCREEN/PLAYBACK**. When finished, press the button again. To answer the call, press **TALK**.

- **To stop the playback temporarily:**  
Press **[9]** during playback. To resume playback, press **[9]** again within 15 seconds.

- **To use the voice menu:**

Call your unit.



Enter your remote code \_\_\_\_\_.



After 3 seconds, the unit starts the voice menu.



Press “1” to use the voice feature.  
OR  
Press “2” to proceed with other functions.



To end the remote operation, hang up.

- **To turn on the answering system:**  
Call your unit and wait for 15 rings. The unit will answer, then hang up.
- **To skip the greeting message:**  
After calling your unit, press **[\*]** during the greeting message playback. Callers can start recording their message after the long beep.

# Adding Another Phone

This unit will not function during a power failure. To connect a standard telephone on the same line, use a Panasonic T-adaptor KX-J66. To order, call 1-800-332-5368.

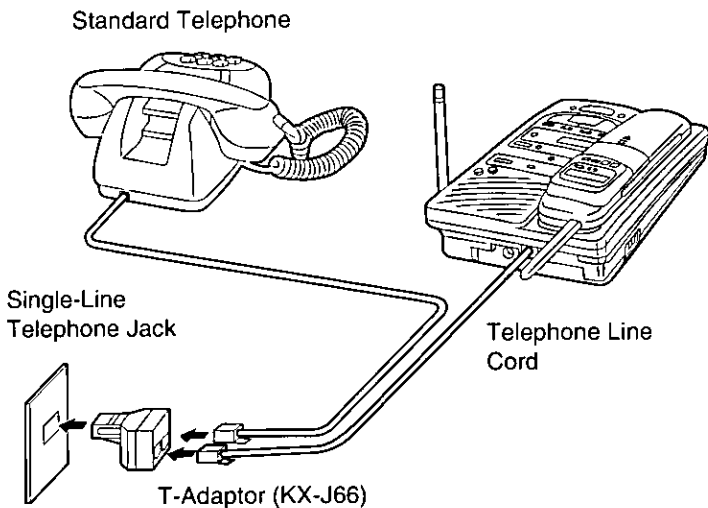

# Optional Spare Battery

When the handset battery needs charging, you may replace it with a fully charged optional spare battery. This eliminates waiting for the handset battery to recharge. **Please purchase a Panasonic P-P592 (KX-A92) battery** and install it in the base unit to charge.

## Installing a spare battery in the base unit

- 1 Open the cradle cover by pushing the tab and lifting the cover.

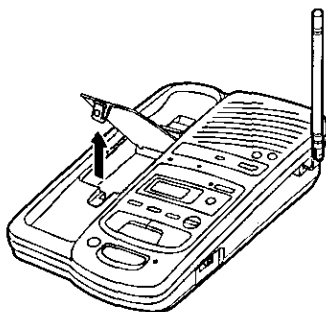

- 2 Install the spare battery as shown observing the proper polarity, then close the cradle cover.

- The SPARE CHARGE indicator lights.

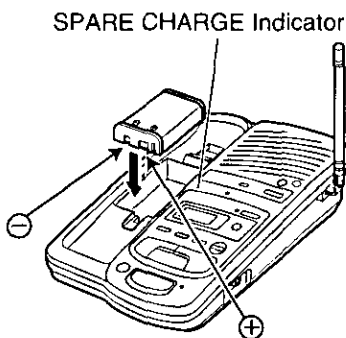

The spare battery is always being charged in the base unit while the AC adaptor is connected. The battery cannot be overcharged.

### Attention:

The product you have purchased is powered by a nickel cadmium battery which is recyclable. At the end of its useful life, under various state and local laws, it is illegal to dispose of this battery into your municipal waste stream. Please call 1-800-8-BATTERY for information on how to recycle this battery.



---

## Replacing the handset battery with the spare battery

To prevent memory loss, replace the battery within 5 minutes.

- 1 Remove the handset cover, then remove the battery.

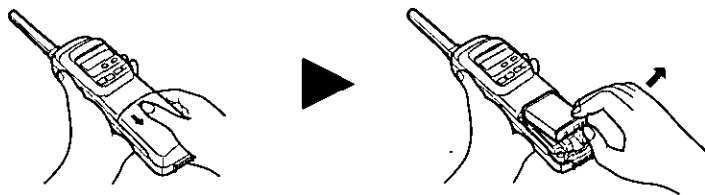

- 2 Replace the handset battery with the spare battery in the base unit.

- ① Remove the spare battery.
- ② Insert the handset battery in the base unit observing the proper polarity.

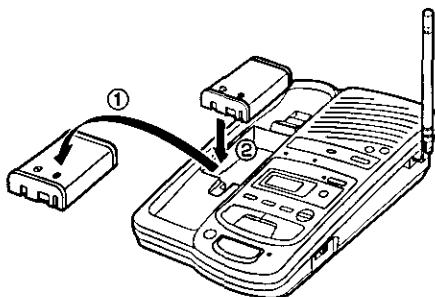

- 3 Install the spare battery in the handset observing the proper polarity.

- When finished, close the handset cover.

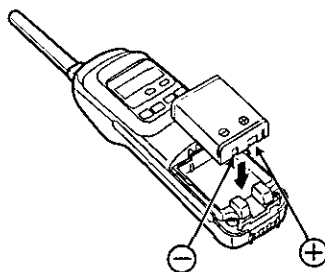

- If the TALK/BATT LOW indicator flashes slowly even when the handset battery has been fully charged, it is time to replace the battery with a new one. Remember to charge the new battery completely after battery replacement.
- Please use only a Panasonic P-P592 (KX-A92) battery. To order, call 1-800-332-5368.

# Before Requesting Help

---

## Cordless telephone

Problem	Remedy
"OUT OF RANGE" is displayed and an alarm tone sounds when you press <b>TALK</b> , <b>INTERCOM</b> or <b>SCREEN/PLAYBACK</b> .	<ul style="list-style-type: none"><li>• You are too far from the base unit. Move closer and try again.</li><li>• Place the handset on the base unit and try again.</li><li>• Plug in the AC adaptor.</li></ul>
An alarm tone sounds continuously while using the handset.	<ul style="list-style-type: none"><li>• Move closer to the base unit quickly, or the call will be terminated within 60 seconds.</li><li>• Plug in the AC adaptor.</li></ul>
Static, sound cuts in/out, fades. Interference from other electrical units.	<ul style="list-style-type: none"><li>• Locate the handset and the base unit away from other electrical appliances (p. 3).</li><li>• Move closer to the base unit.</li><li>• Raise the base unit antenna.</li><li>• Press <b>CH</b> to select a clearer channel.</li></ul>
The handset does not ring.	<ul style="list-style-type: none"><li>• The ringer volume is set to OFF. Press <b>LOUD/RINGER</b> lightly while the TALK/BATT LOW indicator light is off (p. 31).</li></ul>
The base unit does not ring.	<ul style="list-style-type: none"><li>• The RINGER selector is set to OFF. Set to HIGH or LOW (p. 33).</li></ul>
The handset display is blank.	<ul style="list-style-type: none"><li>• The handset is in the stand-by mode (p. 15). Press <b>SEARCH</b> (∨ or ∧) to turn the display on.</li></ul>
The handset display is still blank after pressing <b>SEARCH</b> (∨ or ∧).	<ul style="list-style-type: none"><li>• Charge the battery fully (p. 14).</li></ul>
You cannot program items, such as the dialing mode.	<ul style="list-style-type: none"><li>• Programming is not available while the unit is in the talk or speakerphone mode, or when viewing the caller information.</li></ul>



## Problem

## Remedy

You cannot store a phone number in memory.

- **SEARCH** (v or ^) may have been pressed when you picked up the handset. Press **EXIT**, then try again.
- You cannot store a number while the unit is in the talk, speakerphone or intercom mode.
- Do not pause for over 30 seconds while storing.

While programming or searching, the unit starts to ring and stops the program/search.

- To answer the call, press **TALK** or **DIGITAL SP-PHONE**. Start from the beginning after hanging up.

The unit does not display the name and/or phone number of callers.

- Other telephone equipment may be interfering with your phone. Disconnect them and try again.
- Other electrical appliances connected to the same outlet as the phone may be interfering with the Caller ID information. Telephone line noise may be affecting the Caller ID information.

The handset display becomes blank while searching.

- Do not pause for over 60 seconds while searching.

**LOCATOR/INTERCOM** does not function.

- The handset is too far from the base unit.
- The handset is engaged in an outside call or in the search mode. Wait until the IN USE/CHARGE indicator light goes out.

**REDIAL/PAUSE** does not function properly.

- The button has a double function as either redial or pause. It will redial the last number dialed if pressed at the outset of a call (p. 28). If another number has been dialed first, it will operate as a pause button (p. 49).

## ➔ Before Requesting Help

---

### Answering system

Problem	Remedy
The answering system is on, but no incoming messages are recorded.	<ul style="list-style-type: none"><li>• The recording time is set to “greeting only”. Select “1 minute” or “unlimited” (p. 23).</li><li>• Memory is full. Erase some or all of the messages (p. 53).</li></ul>
“ <b>FULL</b> ” is displayed and the ANSWER ON button light flashes rapidly, and no new messages are recorded.	<ul style="list-style-type: none"><li>• Memory is full. Erase some or all of the messages (p. 53). If “<b>FULL</b>” is still displayed and the ANSWER ON button light flashes rapidly, erase your greeting message and re-record a shorter greeting (p. 20, 21).</li></ul>
Some incoming messages have not been recorded completely.	<ul style="list-style-type: none"><li>• Set the CPC function to “b” (p. 27).</li></ul>
You cannot operate the answering system at the base unit.	<ul style="list-style-type: none"><li>• The handset user is operating the answering system. Wait until the IN USE/CHARGE indicator light goes out.</li></ul>
You cannot operate the answering system from a touch tone phone.	<ul style="list-style-type: none"><li>• Be sure to press the correct remote code.</li><li>• The answering system may not respond if the phone produces tones which are too short to activate the unit. Press each button firmly.</li><li>• The answering system is off. Turn it on (p. 61).</li></ul>
You cannot operate the answering system with the handset.	<ul style="list-style-type: none"><li>• Someone is operating the answering system.</li><li>• You are too far from the base unit. Move closer to the base unit.</li><li>• The unit is receiving a call. To answer the call, press <b>TALK</b>.</li></ul>





Problem	Remedy
While recording a greeting message, the unit starts to ring and stops recording.	<ul style="list-style-type: none"><li>• To answer the call, press <b>DIGITAL SP-PHONE</b>, or lift the handset off the base unit or press <b>TALK</b>. The recording is stopped halfway. Start from the beginning after hanging up.</li></ul>
During playback, the unit starts to ring and stops playback.	<ul style="list-style-type: none"><li>• To answer the call, press <b>DIGITAL SP-PHONE</b>, or lift the handset off the base unit or press <b>TALK</b>. To resume playback, press <b>NEW MESSAGE</b> after hanging up.</li></ul>
The handset does not display the caller's name and/or number whose message is being played.	<ul style="list-style-type: none"><li>• Place the handset on the base unit correctly (p. 52).</li><li>• If the caller is not in the caller list, the handset will not display the caller's information.</li></ul>

## ➔ Before Requesting Help

---

### General

Problem	Remedy
The unit does not work.	<ul style="list-style-type: none"><li>• Check the settings (p. 13-19).</li><li>• Charge the battery fully (p. 14).</li><li>• Clean the charge contacts and charge again (p. 15).</li><li>• Install the battery properly (p. 13).</li><li>• Place the handset on the base unit and unplug the AC adaptor to reset. Plug in, then try again.</li><li>• Re-install the handset battery within 5 minutes to avoid memory loss and try again.</li></ul>
You cannot program items, such as the time/day adjustment (p. 22).	<ul style="list-style-type: none"><li>• Programming is not available while the unit is in the talk or speakerphone mode, or when viewing the caller information.</li><li>• Move closer to the base unit.</li></ul>
The TALK/BATT LOW indicator flashes slowly or the unit beeps intermittently.	<ul style="list-style-type: none"><li>• Charge the battery fully or replace with a fully charged optional spare battery (p. 14, 69).</li></ul>
You charged the battery fully, but the TALK/BATT LOW indicator flashes slowly.	<ul style="list-style-type: none"><li>• Clean the charge contacts and charge again (p. 15).</li><li>• Replace the battery. Please purchase a new battery (p. 68).</li></ul>
The IN USE/CHARGE indicator and/or the SPARE CHARGE indicator light never goes out while charging.	<ul style="list-style-type: none"><li>• This is normal.</li></ul>
If you cannot solve your problem.	<ul style="list-style-type: none"><li>• Call our customer call center at 1-800-211-PANA(7262).</li></ul>

# Important Safety Instructions



When using this unit, basic safety precautions should always be followed to reduce the risk of fire, electric shock, or personal injury.

1. Read and understand all instructions.
2. Follow all warnings and instructions marked on this unit.
3. Unplug this unit from AC outlets before cleaning. Do not use liquid or aerosol cleaners. Use a damp cloth for cleaning.
4. Do not use this unit near water, for example, near a bathtub, washbowl, kitchen sink, or the like.
5. Place this unit securely on a stable surface. Serious damage and/or injury may result if the unit falls.
6. Do not cover slots and openings on the unit. They are provided for ventilation and protection against overheating. Never place the unit near radiators, or in a place where proper ventilation is not provided.
7. Use only the power source marked on the unit. If you are not sure of the type of power supplied to your home, consult your dealer or local power company.
8. Do not place objects on the power cord. Install the unit where no one can step or trip on the cord.
9. Do not overload wall outlets and extension cords. This can result in the risk of fire or electric shock.
10. Never push any objects through slots in this unit. This may result in the risk of fire or electric shock. Never spill any liquid on the unit.
11. To reduce the risk of electric shock, do not disassemble this unit. Take the unit to an authorized servicenter when service is required. Opening or removing covers may expose you to dangerous voltages or other risks. Incorrect reassembly can cause electric shock when the unit is subsequently used.
12. Unplug this unit from the wall outlet and refer servicing to an authorized servicenter when the following conditions occur:
  - A. When the power supply cord or plug is damaged or frayed.
  - B. If liquid has been spilled into the unit.
  - C. If the unit has been exposed to rain or water.
  - D. If the unit does not work normally by following the operating instructions. Adjust only controls covered by the operating instructions. Improper adjustment may require extensive work by an authorized servicenter.
  - E. If the unit has been dropped or physically damaged.
  - F. If the unit exhibits a distinct change in performance.
13. During thunderstorms, avoid using telephones except cordless types. There may be a remote risk of an electric shock from lightning.
14. Do not use this unit to report a gas leak, when in the vicinity of the leak.

## SAVE THESE INSTRUCTIONS

## Important Safety Instructions

---

### **CAUTION:**

To reduce the risk of fire or injury to persons, read and follow these instructions.

1. Use only the battery(ies) specified.
2. Do not dispose of the battery(ies) in a fire. They may explode. Check with local waste management codes for special disposal instructions.
3. Do not open or mutilate the battery(ies). Released electrolyte is corrosive and may cause burns or injury to the eyes or skin. The electrolyte may be toxic if swallowed.
4. Exercise care in handling batteries in order not to short the battery to conductive materials such as rings, bracelets, and keys. The battery and/or conductor may overheat and cause burns.
5. Charge the battery(ies) provided with or identified for use with this product only in accordance with the instructions and limitations specified in this manual.

### **WARNING:**

**TO PREVENT FIRE OR SHOCK HAZARD, DO NOT EXPOSE THIS PRODUCT TO RAIN OR ANY TYPE OF MOISTURE.**

# FCC and Other Information



If requested by the telephone company, inform them as follows:

FCC Registration No. ....(found on the bottom of the unit)  
Ringer Equivalence .....0.2B  
The particular telephone line to which the equipment is connected.

This unit must not be connected to a coin operated line.

If you are on a party line, check with your local telephone company.

## **Ringer Equivalence No. (REN):**

The REN is useful in determining the quantity of devices you may connect to your telephone line and still have all of those devices ring when your telephone number is called. In most, but not all areas, the sum of the REN's of all devices connected to one line should not exceed five (5.0). To be certain of the number of devices you may connect to your line, as determined by the REN, you should contact your local telephone company to determine the maximum REN for your calling area.

In the event terminal equipment causes harm to the telephone network, the telephone company should notify the customer, if possible, that service may be stopped.

However, where prior notice is impractical, the company may temporarily cease service providing that they:

- (a) Promptly notify the customer.
- (b) Give the customer an opportunity to correct the problem with their equipment.
- (c) Inform the customer of the right to bring a complaint to the Federal Communication Commission pursuant to procedures set out in FCC Rules and Regulations Subpart E of Part 68.

The Telephone Company may make changes in its communications facilities, equipment, operations or procedures, where such action is reasonably required in the operation of its business and is not inconsistent with the rules and regulations in FCC Part 68.

If such changes can be reasonably expected to render any customer terminal equipment incompatible with telephone company communications facilities, or require modification or alteration of such terminal equipment, or otherwise materially affect its use or performance, the customer shall be given adequate notice in writing, to allow the customer an opportunity to maintain uninterrupted service.

When programming emergency numbers and/or making test calls to emergency numbers:

1. Remain on the line and briefly explain to the dispatcher the reason for the call before hanging up.
2. Perform such activities in the off-peak hours, such as early morning hours or late evenings.

## ➡ FCC and Other Information

---

This device complies with Part 15 of the FCC Rules. Operation is subject to the following two conditions: (1) This device may not cause harmful interference, and (2) this device must accept any interference received, including interference that may cause undesired operation.

Privacy of communications may not be ensured when using this phone.

### **CAUTION:**

Any changes or modifications not expressly approved by the party responsible for compliance could void the user's authority to operate this device.

### **Note:**

This equipment has been tested and found to comply with the limits for a Class B digital device, pursuant to Part 15 of the FCC Rules. These limits are designed to provide reasonable protection against harmful interference in a residential installation. This equipment generates, uses, and can radiate radio frequency energy and, if not installed and used in accordance with the instructions, may cause harmful interference to radio communications. However, there is no guarantee that interference will not occur in a particular installation. If this equipment does cause harmful interference to radio or television reception, which can be determined by turning the equipment off and on, the user is encouraged to try to correct the interference by one or more of the following measures:

- Reorient or relocate the receiving antenna.
- Increase the separation between the equipment and receiver.
- Connect the equipment into an outlet on a circuit different from that to which the receiver is connected.
- Consult the dealer or an experienced radio/TV technician for help.

Some cordless telephones operate at frequencies that may cause interference to nearby TVs and VCRs. To minimize or prevent such interference, the base of the cordless telephone should not be placed near or on top of a TV or VCR. If interference is experienced, move the cordless telephone further away from the TV or VCR. This will often reduce or eliminate interference.

- **Environment** — do not place the unit in room where the temperature is less than 5°C (41°F) or greater than 40°C (104°F). Allow 10 cm (4") clearance around the unit for proper ventilation. Avoid excessive smoke, dust, mechanical vibration, shock, or direct sunlight.
- **Routine care** — wipe the unit with a soft cloth. Do not use benzine, thinner, or any abrasive powder. When you left the unit unused for long time, unplug the AC adaptor from the outlet.
- **If there is any trouble** — disconnect the unit from the telephone line and connect a known working phone. If the known working phone operates properly, have your unit repaired by one of the authorized Panasonic Factory Service Centers. If the known working phone does not operate properly, consult with your telephone company.

## For product service

- Panasonic Servicenters are listed in the servicenter directory.
- Call 1-800-211-PANA(7262) for the location of an authorized servicenter.

## When you ship the product

- Carefully pack your unit, preferably in the original carton.
- Attach a letter, detailing the symptom, to the outside of the carton.

### Symptom

---

- Send the unit to an authorized servicenter, prepaid and adequately insured.
- Do not send your unit to the Panasonic Consumer Electronics Company listed on the back cover or to executive or regional sales offices. These locations do not repair consumer products.

• This cordless telephone is designed for use in the United States of America. Sale or use of this product in other countries may violate local laws.

• Ce téléphone sans fil est conçu pour être utilisé aux États-Unis d'Amérique. La vente ou l'emploi de cet appareil dans certains autres pays peut constituer une infraction à la législation locale.

• Este teléfono sin cordón fue elaborado para uso en los Estados Unidos de América. La venta o el empleo de este producto en ciertos países puede constituir violación de la legislación local.

• このコードレス電話機は、日本国外での使用を目的として設計されており、日本国内での使用は法律違反となります。従って、当社では日本国内においては原則として修理などのサービスは致しかねます。

**Panasonic Consumer Electronics Company,  
Division of Matsushita Electric Corporation of America**  
One Panasonic Way, Secaucus, New Jersey 07094

**Panasonic Sales Company,  
Division of Matsushita Electric of Puerto Rico, Inc.**  
Ave. 65 de Infantería, Km. 9.5, San Gabriel Industrial Park  
Carolina, Puerto Rico 00985