



SAFETY PRECAUTIONS	1
INTRODUCTION	2
INSTALLATION CONNECTIONS	3
DETAILED INSTALLATION	4
DESIGN PHILOSOPHY	7
TECHNICAL DATA	10
CARE and HANDLING	11
WARRANTY	12
WARRANTY REGISTRATION	13
ADDRESS	14

CAUTION		
	WARNING	
CAUTION: TO PREVENT ELECTRIC SHOCK, DO NOT REMOVE COVER. NO USER SERVICEABLE PARTS INSIDE, REFER SERVICING TO QUALIFIED SERVICE PERSONNEL.		
	THIS SYMBOL IS TO ALERT YOU OF THE PRESENCE OF UNINSULATED DANGEROUS VOLTAGE WITHIN THE UNIT'S ENCLOSURE THAT MAY BE OF SUFFICIENT MAGNITUDE TO CONSTITUTE A RISK OF ELECTRIC SHOCK.	
	THIS SYMBOL IS INTENDED TO ALERT YOU OF THE PRESENCE OF IMPORTANT OPERATING AND MAINTENANCE INSTRUCTIONS IN THE LITERATURE ACCOMPANYING THE UNIT.	

WARNING: TO PREVENT FIRE OR SHOCK HAZARD, DO NOT EXPOSE THIS UNIT TO RAIN OR MOISTURE. TO AVOID ELECTRICAL SHOCK, DO NOT OPEN THE UNIT. REFER SERVICING TO QUALIFIED PERSONNEL.

- CAUTION** -
- Never install or remove the power cord from the chassis unless it has been disconnected from the AC power source first.
 - Never pull on the power cord when removing it from an AC power source. Grasp it by the plug.
 - Do not leave the power cord connected to an AC power source unless it is connected to the unit.
 - It is recommend that during extended periods of nonuse that the units power cord be unplugged from its AC power source.
 - Route the AC power cord so that it will not be damaged or walked on.

This preamplifier is a precision device, designed in an effort to provide the listener with unmatched sound quality, design, and construction. In order to operate your preamplifier properly and to realize all of the capabilities of the FET PREAMPLIFIER 02b, we recommend that you read this entire manual carefully.

The first section of the installation instructions for the FET PREAMPLIFIER 02b is a diagram of the basic configuration required to bring the preamplifier into an operating mode. These brief steps will allow you to begin operating your system. Make sure during installation that the level control is turned fully counter clockwise, all other components are off, and AC power connections are interrupted to the preamplifier. While the diagram may be self explanatory, we strongly recommend that you read the detailed instructions following this introductory section.

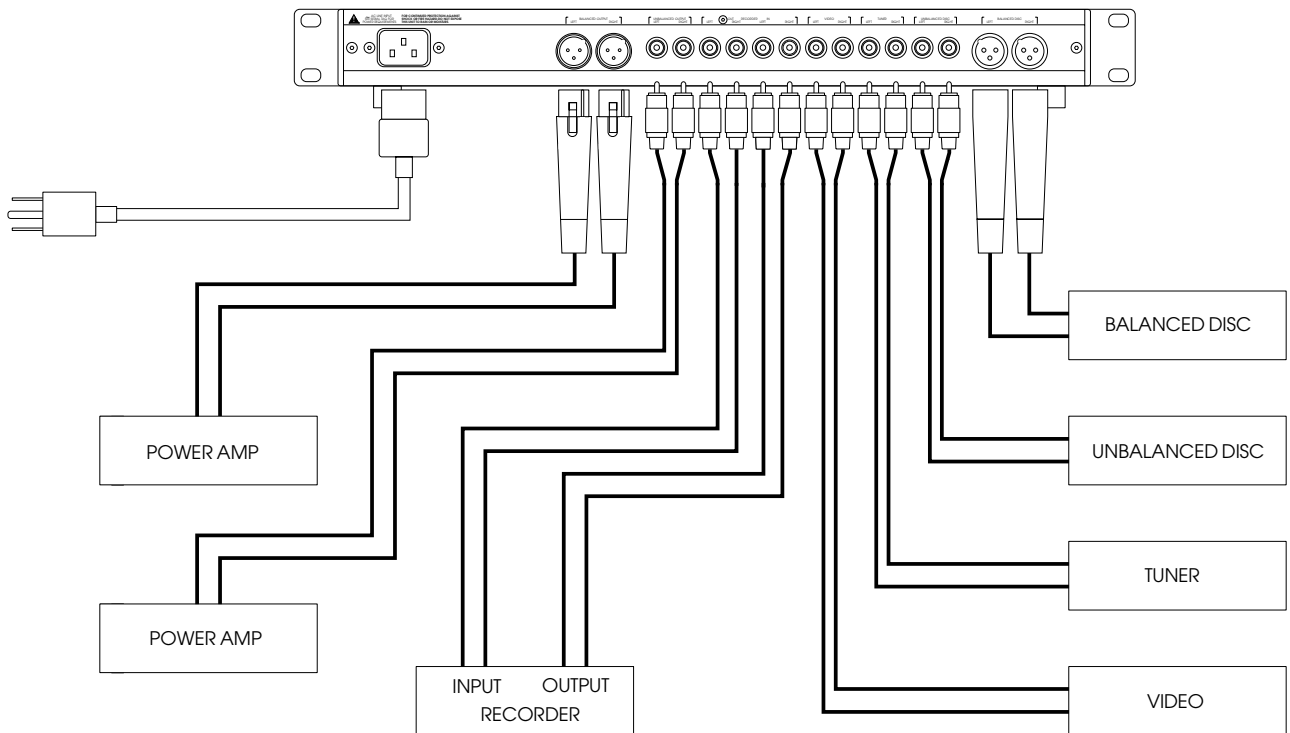

I. Set up and Installation

WARNING: NEVER OPERATE THIS UNIT WITH THE TOP COVER REMOVED. NEVER MAKE ANY INTERNAL ADJUSTMENTS WHILE THIS UNIT IS CONNECTED TO AN AC POWER SOURCE.

1. Position the FET PREAMPLIFIER 02b in the space which you have chosen, leaving enough space to connect the ancillary components of your audio system, and the AC power cord for the preamplifier. Although the FET PREAMPLIFIER 02b has the ability to reject external fields that produce system noise, it is recommended that the unit not be placed near any sources of strong electromagnetic energy.

2. Before installing the preamplifier make sure all of the power switches of any associated components are switched off. If any of your other audio components do not have power switches, make sure they are unplugged from their AC power source.



Note: The Operating Voltage of the FET PREAMPLIFIER 02b is convertible in order that it may be used worldwide. Contact your dealer to arrange altering the operating voltage.

III. Front Panel Control Functions

1. The INPUT SELECTOR control selects the source which will be presented to the outputs and balanced outputs.
2. The RECORD SELECTOR control selects the source which will be presented to the record output. Because of the independent controls, one source may be monitored while a second, different source is being recorded.
3. The BALANCE control works by attenuating the right channel when being rotated from the detent in the counterclockwise direction, and conversely, the left channel for clockwise rotation. The element is conductive plastic. Adjustment is continuously adjustable allowing for infinitesimal adjustments to match channel gain, which is impossible with stepped controls.
4. The OUTPUT LEVEL control is a precision tracking, audio taper, conductive plastic potentiometer used to adjust the voltage level at the outputs and balanced outputs. Clockwise rotation, of course, increases output.

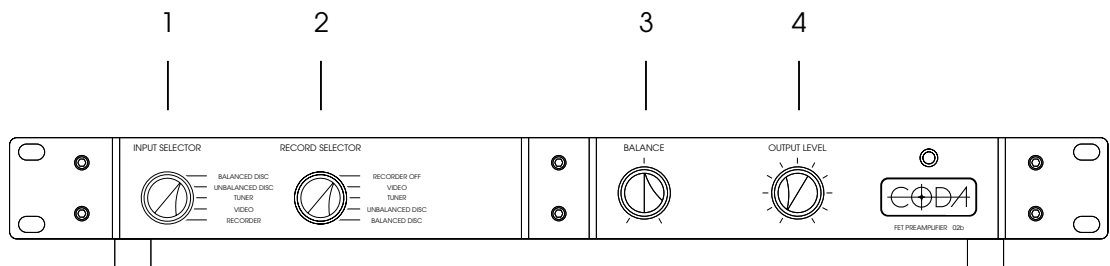

Select a source with the INPUT SELECTOR switch and advance the OUTPUT LEVEL control to the level you wish. Keep in mind that your input sources will vary in level which can, when switching from one input to another, abruptly yield uncomfortable sound pressure.

Note: If a power interruption occurs to the system, reduce the OUTPUT LEVEL control gain. The resumption of power will cause no noise pulses in the FET PREAMPLIFIER 02b. However, some sources may produce high output voltages on turn on, which may cause damage to an amplifier or speakers .

I. Design Philosophy and Approach

The circuitry utilized in the FET PREAMPLIFIER 02b is the result of an advanced and complete design process combining innovation and proven fundamentals. This process avoids both the limitations of total adherence to convention and the flaws resulting from inappropriate application of clever circuit gimmicks. Our approach demands painstaking consideration of every facet of each design choice regardless of how small. Analytical, as well as subjective techniques are all applied in an open-minded fashion with “no compromise” musical perfection as the goal. The resulting refinement of the product escapes simple explanation. With this in mind, we present here a few design highlights and concepts.

All voltage gain is derived from FETs. While careful design can yield good results from any device type, FETs consistently seem to have the edge in voltage gain and interface applications. This is borne out by superior sonic qualities observed in subjective testing. FETs are inherently transconductance devices, meaning that an input voltage controls an output current. In other words, it “senses” the audio signal without drawing current from the source to provide an output. This eliminates complex interactions with the source allowing maximum performance from each system element and greatly reducing the chance of cable characteristics altering the sound. The absence of input current in FETs also allows high bias currents for linearity and speed without sacrificing DC parameters.

While excellent capacitors for coupling use exist, there can be no doubt that a signal path free of coupling caps yields the best possible signal integrity. The DC stability of the circuit eliminates the need for any questionable DC servo circuits or coupling capacitors. We make no AC compromises for DC performance, however. Our key design choices provide not only inherent DC stability, but also optimized AC performance throughout the audio region and well beyond. These choices include the use of top quality dual FETs in differential configurations for all voltage gain. Because the signal in these stages is handled in a balanced manner, rejection of unwanted noise and modulation from external sources is extremely high. This rejection extends even to noise which may originate within the circuit from support circuitry such as current sources. Stray RF signals are also rejected well.

The class A complimentary followers used to drive the preamp output are of such speed, linearity, and low output impedance that no feedback correction is required or used. The advantage of this is that the circuit’s perfect stability and transient response are preserved into a wide range of difficult and unpredictable loads. Variation in sound which could occur through interactions with interconnect cables and other system elements are thus avoided.

To accomplish balanced inputs and outputs, the FET PREAMPLIFIER 02b uses simple very high performance inverters. The most commonly acknowledged advantage of this is rejection of stray noise pickup, but improvements in distortion and bandwidth may occur also.

The FET PREAMPLIFIER 02b controls provide an off position for the recording output. This completely disconnects the recording system from the main system to prevent possible interactions which may affect sound quality.

The requirements of a power supply for flawless audio reproduction are straightforward but important. The supplies in the FET PREAMPLIFIER 02b take a very direct approach to high performance. First, a top quality shielded toroid transformer with plenty of reserve current capability is used. About 28,000 uF of capacitance with very low ESR and inductance provides good passive filtering. A reference voltage is developed by delivering a constant current to zener diodes. The resulting voltage is heavily filtered and delivered to each stage through independent class A followers which completely decouples the stages. The resulting non-reactive low impedance over an extremely wide bandwidth yields a perfect power source for the individual circuits. The simplicity and absolute stability of the supplies removes the chance of unpredictable interactions which may occur with the more elaborate, high feedback circuitry often used.

Most companies in the upper end of the audio industry use either sheet metal or formed aluminum. By contrast, the FET PREAMPLIFIER 02b has all structural parts made of machined extruded aluminum. The advantage of this over an all stamped chassis is that the machined metal can be worked more precisely allowing us to work on tighter tolerances and use PC mounted parts more easily. Moreover such a design allows easier servicing either for repair or for future upgrading. From the standpoint of appearance, a machined surface can be contoured in a far more precise manner, giving the final product a more seamless appearance.

II. Parts' Quality

1. Finishes - All exterior and interior metal parts are anodized. While paint may be more impact resistant, the anodized surface is more resistant to solvents and prevents corrosion. Moreover, the anodized parts' appearance can be enhanced by either graining or bead-blasting the surface.

2. Circuit Board - Circuit boards are fiberglass epoxy with gold plating over a tin/nickel barrier. This gold layer will not corrode, while the barrier plate prevents the gold from migrating to the lower copper layer and detracting from its appearance.

3. Resistors - All are high reliability metal film 1% resistors.

4. Capacitors - All capacitors have been eliminated where possible on the basis that "no cap is better than the best cap". The only electrolytics used are in the power supply where large numbers provide enormous filtering capacitance for the supply.

5. Semiconductors - There are no integrated circuits (IC) to be found in this product. Very high quality dual FETs are the only source of voltage gain and were selected for their superb noise performance and precision matching. The remaining semiconductors are also of very high quality, each possessing parameters ideally suited for the specific application.

6. Potentiometers - The volume controls are conductive plastic. These pots track with little error and are totally neutral.

7. Connectors - Coda employs a standard RCA configuration with a gold plated case. The balanced connectors are Neutriks from Switzerland.

8. Wire - All signal wire has been eliminated whenever possible. Where wire is used, Coda employs silver plated copper, 141 strand, 18 gauge wire with a silicone insulation.

CIRCUIT SPECIFICATIONS

Frequency Response:	DC to -3 dB @ 200 kHz
Distortion:	< .01 % from 10 Hz to 40 kHz @ 6V peak into 600 Ohms or higher, shunted by 1000 pF or less .
Gain:	with unbalanced in and unbalanced out 14 dB with balanced in and unbalanced out 14 dB with unbalanced in and balanced out 20 dB with balanced in and balanced out 20 dB
Maximum Output:	12 Volts peak
Noise:	> 100 dBA referenced to 1 Volt output
Input Impedance:	unbalanced 20 k Ohms balanced 20 k Ohms
Output Impedance:	15 Ohms non-reactive unbalanced 30 Ohms non-reactive balanced
Crosstalk:	70 dB @ 20 kHz

POWER SUPPLY

independently regulated with shielded toroidal transformer and 28,000 uf of capacitance

DIMENSIONS

Height:	1.75" Faceplate, 2.35" Overall
Width:	19.0" Faceplate, 17.0" Chassis
Depth:	9.75" Overall
Weight:	14 lbs. Shipping

The interior of the unit requires no special care, due to the use of sealed controls and gold plating on contacts. If it becomes necessary to clean the exterior, a simple dusting may be all that is required. If a cleaner is necessary, any dilute commercial ammonia based product will be appropriate. NEVER use any abrasive rags, cleaners or chemical solvents on the preamp.

When handling the unit, take care not to mar the aluminum. Aluminum is a medium hardness metal and can be scratched by the harder tool steels.

Avoid exposing the unit to direct sunlight, and keep it away from sources of intense heat.

If you wish to rack mount your FET PREAMPLIFIER 02b, it is advised to place nylon washers under the heads of the mounting screws to avoid scratching the anodized finish.

Do not throw away the carton or associated packing material. They are ideal if you need to pack the unit for moving, and in the unlikely event that servicing is needed, they will be necessary for safe shipment.

Be sure to provide adequate insurance when shipping.

I. Warranty- Any failure of the FET Preamplifier 02b to operate or to meet specifications, applicable at time of manufacture, due to a manufacturing defect or component failure, will be corrected by Coda Technologies, Inc. without charge for parts, or labor for a period of **ten years** from date of original purchase. Coda Technologies, Inc. will provide for surface transportation to and from the factory from an authorized Coda Technologies, Inc. dealer for a period of one year from date of purchase.

II. Procedure- **If the FET Preamplifier 02b should require service under warranty, take it with proof of purchase date, with its carton and packing material, to a Coda Technologies, Inc. dealer.** The dealer will arrange for service. Direct shipments to the factory will be accepted at the discretion of the company. Coda Technologies, Inc. products purchased outside of the U.S. will be covered by those warranty conditions extended by the importing distributor which may differ in some respects from those given above. Warranty service, if required, is the responsibility of the importing distributor. If a Coda Technologies, Inc. product is removed from the country of original purchase, Coda Technologies, Inc. distributors or dealers are not obligated by the conditions of this warranty and repairs will be affected at their discretion.

III. Exclusion of Coverage- At the sole opinion of Coda Technologies, Inc. the following situations are specifically excluded from coverage:

1. Any FET Preamplifier 02b not operated in accordance with the instructions contained in this manual, or otherwise subjected to abuse, tampering, modification, accidental damage, or serial number defacement.
2. Damage to other property caused by any defects in this product, damages based upon inconvenience, loss of use of the product, loss of time, commercial loss, or any other damage whether incidental, consequential, or otherwise.
3. It is Coda Technologies, Inc. policy to extend coverage when reasonable doubt exist; however, freight charges will be billed for any units returned under warranty and found by the company to be operating according to specification.

This warranty gives you specific legal rights, and you may also have other rights which vary from state to state.

Coda Technologies, Inc. continually researches new techniques, designs, and construction methods and so reserves the right to introduce refinements into current product lines without notice or obligation. The company may offer product modifications to make these refinements available to earlier production units.

Fill in and retain this copy of the warranty registration sheet for your records .

MODEL DESIGNATION:_____

SERIAL NUMBER:_____

DATE OF PURCHASE:_____

PLACE OF PURCHASE

Dealer:_____

Address:_____

City:_____ State:____ Zip:_____

Phone:_____

PURCHASER

Name:_____

Address:_____

City:_____ State:____ Zip:_____

Phone:_____

NOTES: _____

Please fill in and send this copy of the warranty registration sheet to Coda Technologies, Inc. Include copy of proof of purchase.

MODEL DESIGNATION: _____

SERIAL NUMBER: _____

DATE OF PURCHASE: _____

PLACE OF PURCHASE

Dealer: _____

Address: _____

City: _____ State: ____ Zip: _____

Phone: _____

PURCHASER

Name: _____

Address: _____

City: _____ State: ____ Zip: _____

Phone: _____

NOTES: _____

Coda Technologies, Inc.
9941 Horn Road Suite A
Sacramento, CA 95827

Phone: (916) 363-4653
Fax: (916) 363-4627