

EF20B

Fisher-Price®

*Safe Voyage™ Deluxe
Convertible Car Seat*



www.fisher-price.com

Safety Information

Warnings	3-4	Check Buckle Position	30
Safety Information	5	Installation in Aircraft	31
Features	6-7	Rear-Facing Installation.....	31
Using the Restraint	8	Forward-Facing Installation	31
Secure Your Child in the Restraint.....	8-9	Using the Tether	32-33
Reclined Position.....	10	Care and Maintenance	34
Upright Position	11	Cover Removal and Replacement	34
Check Harness Height.....	12	Cleaning the Cover, Shell and Harness	
Harness Height Adjustment	13	and Harness Adjuster	35
Vehicle Safety Belts	14	Buckle Removal and Replacement	36
Vehicle Seating Positions	15	Cleaning the Buckle.....	37
Rear-Facing Installation	16	Warranty	38
LATCH Installation and Removal.....	16-17		
Locking Lap-Shoulder Belt Installation	18-19		
Non-Locking ELR Lap-Shoulder Belt			
Installation Using a Locking Clip.....	20-21		
Lap Belt Installation	22-23		
Forward-Facing Installation	24		
LATCH Installation and Removal.....	24-25		
Locking Lap-Shoulder Belt Installation	26		
Non-Locking ELR Lap-Shoulder Belt			
Installation Using a Locking Clip.....	27-28		
Lap Belt Installation	29		

Fisher-Price and related trademarks and copyrights are used under license from Fisher-Price, Inc., a subsidiary of Mattel, Inc., East Aurora, NY 14052, U.S.A. ©2006 Mattel, Inc. All Rights Reserved. MADE IN U.S.A.

Manufactured for and distributed by a subsidiary of:
Britax Childcare Limited

P266700
R1.01.06

WARNING

- Use rear-facing position when using restraint with an infant weighing 20 pounds (9 kg) or less. The American Academy of Pediatrics recommends rear-facing until at least 1 year of age and 20 pounds.
- Use only with children who weigh between 5 and 55 pounds (2.3 and 25 kg) and whose height is 49 inches (124 cm) or less. Rear-facing 5-33 pounds (2.3-15 kg) and forward-facing maximum 55 pounds (25 kg).
- Snugly adjust the belts provided with this child restraint around your child. A snug strap should not allow any slack. It lies in a relatively straight line without sagging. It does not press on the child's flesh or push the child's body into an unnatural position.
- Secure the top anchorage strap (tether) provided with this child restraint.
- Secure this child restraint with the vehicle's child restraint anchorage system (LATCH) if available or with a vehicle belt.
- Follow all instructions on this child restraint and in the written instructions stored under cover at front of seat.
- Register your child restraint with the manufacturer.
- This child restraint must not be used in the home, in boats, or other non-certified applications.
- Use vehicle belt (not lower connectors) for installations with children weighing more than 48 pounds (21 kg). Refer to the vehicle owner's manual or contact the vehicle manufacturer for the maximum weight rating for their lower anchors. Unless specified otherwise by the vehicle manufacturer, assume a 48-pound child is the vehicle lower anchor limit.

WARNING

- Based on crash statistics, the National Highway Traffic Safety Administration recommends that parents select the rear seat as the safest location for a properly installed child restraint. Please study the section on *Vehicle Safety Belts* in this booklet to ensure the child's safety. If in doubt about installing the child restraint, consult the vehicle owner's manual.
- Secure this child restraint even when it is not occupied. In a crash, an unsecured child restraint may injure vehicle occupants.
- When using in vehicle with air bags, refer to the vehicle owner's manual for child restraint installation instructions and precautions.
- Never use the adjuster strap to lift or carry this child restraint. Doing so could cause damage to the harness adjuster and webbing. Always carry this child restraint by the shell or tether strap.
- The primary protection for occupants of a vehicle in a crash is the structure of the vehicle; a child restraint will not protect a child when the vehicle is seriously impacted. However, correctly installed, a child restraint will substantially improve the chances for survival in most crashes. Make sure that all users fully understand the correct ways to use this child restraint in a vehicle.
- Stop use of a child restraint that is older than six years or has been in a severe crash to prevent injury due to deterioration or hidden damage.

Safety Information

IMPORTANT NOTES

- Verify that the child restraint is secure and that the harness is properly adjusted around the child each time the child restraint is used.
- Adjust the harness to fit the clothes the child is wearing. The fit for a child in winter clothes will differ from a child in summer clothes.
- Cover the restraint when the vehicle is parked in direct sunlight. Parts of the child restraint could become hot enough to burn the child.
- Store the child restraint in a safe place when it is not being used for an extended period of time. Do not place heavy objects on top of it.
- Do not leave children alone in a vehicle, even for a short time.
- Do not, except as described in this booklet, attempt to disassemble any part of the child restraint or change the way its harness or the vehicle belts are used.
- Do not leave loose objects, e.g. books, bags, etc., in the back of a vehicle. In the event of a sudden stop, loose objects will keep moving, potentially causing serious injuries.
- Do not leave folding vehicle seats unlatched. In the event of a sudden stop, a loose seat back could prevent the child restraint from protecting the child as well as it should.
- Do not allow children to play with the child restraint.
- Do not use anything to raise the restraint off the vehicle seat. In a crash, it could slide and be unable to protect the child as well as it should.

This child restraint system conforms to all applicable Federal motor vehicle safety standards. **THIS RESTRAINT IS CERTIFIED FOR USE IN MOTOR VEHICLES AND AIRCRAFT.**

Child restraints could be recalled for safety reasons. You must register this restraint to be reached in a recall. Send your name, address and the restraint's model number and manufacturing date to Britax Child Safety, Inc., 13501 South Ridge Drive, Charlotte, NC 28273 or call 1-866-204-1665. For recall information, call the U.S. Government's Vehicle Safety Hotline at 1-888-327-4236 (TTY: 1-800-424-9153), or go to <http://NHTSA.gov>.

WARNING



Do not place a child restraint in the front seat of a vehicle with a passenger air bag. Death or serious injury can occur. The back seat is the safest place for children under 12 years of age.

Features

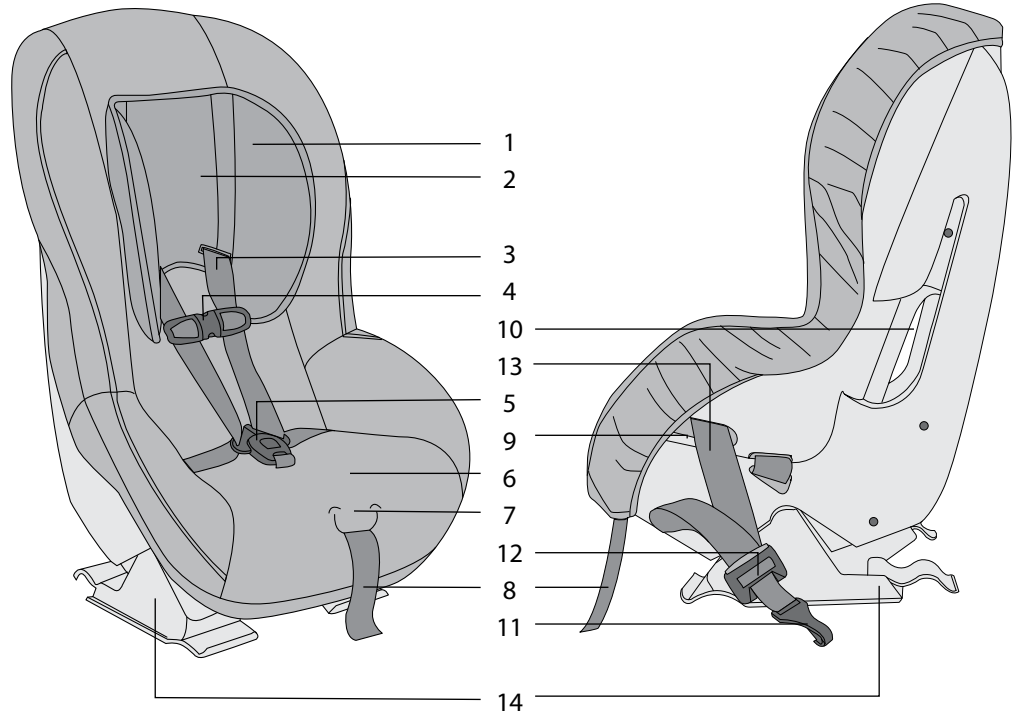

- 1. Head pad
- 2. Harness Slots (under Head Pad)
- 3. Harness
- 4. Chest Clip
- 5. Buckle
- 6. User Guide and Locking Clip (under cover)
- 7. Harness Adjuster Lever (under flap)

- 8. Harness Adjuster Strap
- 9. Rear-Facing Vehicle Belt Path
- 10. Forward-Facing Vehicle Belt Path
- 11. Lower Hook
- 12. Lower Adjuster
- 13. Lower Hook Strap
- 14. Base

Features

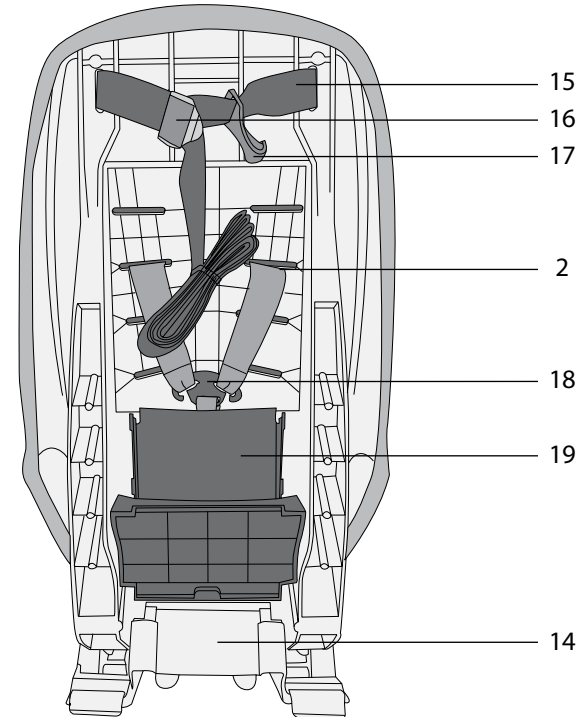

- 15. Tether
- 16. Tether Adjuster
- 17. Tether Hook

- 18. Harness Yoke
- 19. Harness Shield

Using the Restraint

Secure Your Child in the Restraint

1. To loosen the harness, lift the adjuster lever located in front of the restraint and pull the harness straps forward (**Fig. 1**).
2. To unfasten chest clip, squeeze tabs (**Fig. 2**). Separate clip (**Fig. 3**).
3. To unfasten buckle, use thumb to press release button, then remove tongues from buckle (**Fig. 4**).

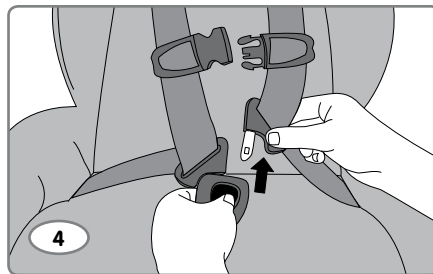
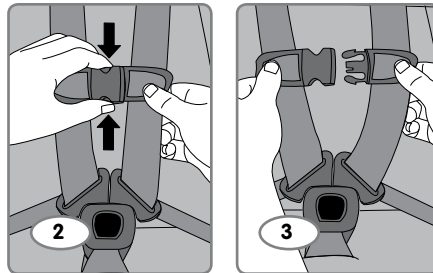
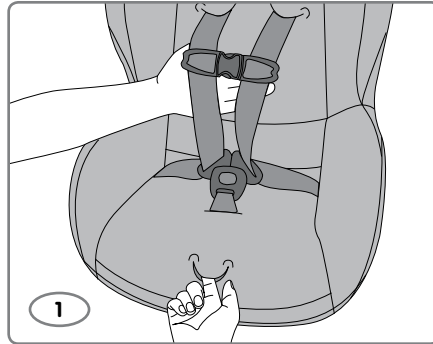

Using the Restraint

4. Place child in the restraint. Position the harness straps around the child and fasten the child restraint buckle (**Fig. 5**). Fasten chest clip (**Fig. 6**).
 5. Gently pull up on the harness straps to tighten the lap section of the harness.
 6. Slowly pull the adjuster strap to tighten the harness around the child (**Fig. 7**).
- IMPORTANT!** *Harness should have a snug, but comfortable, fit around the child.*
7. Position the chest clip at the middle of the child's chest, level with the child's armpits (**Fig. 7**).
 8. Check harness height (see page 12).
 9. Verify that harness is not twisted and child is properly secured.

IMPORTANT! *Always pull on the harness after securing the child to make sure the buckle and harness are locked. If they are not, the buckle or adjuster area may be clogged with food, drink, or objects that need to be removed. See pages 35 -37 for cleaning instructions.*

IMPORTANT! *Always make sure that the harness is tight before each use, or after any adjustments.*

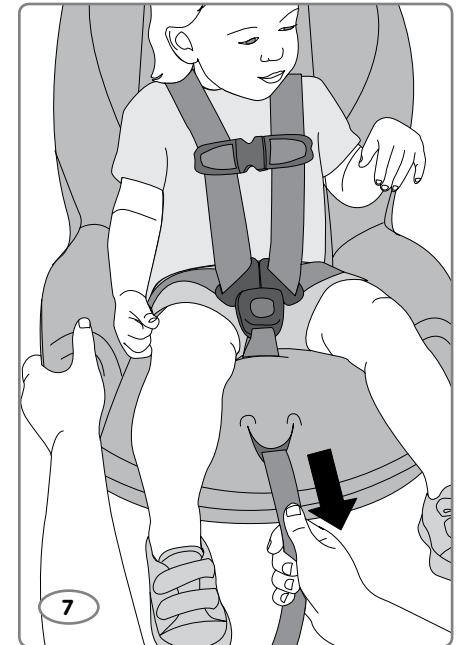
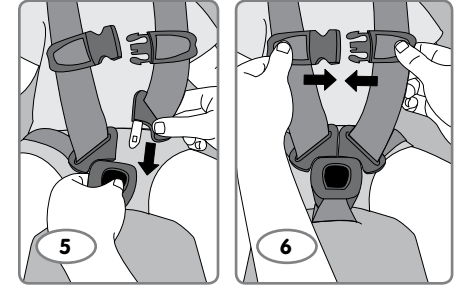

Using the Restraint

Reclined Position

Use the rear-facing, reclined position with children weighing 33 pounds (15 kg) or less (*Fig. 1*).

WARNING

Always use in reclined position in rear-facing mode.

1. To adjust the restraint to the reclined position, turn the restraint upside down so the base is facing up. With both hands, pull up on the base to disengage the rods. Pull base away from shell, then rotate to the reclined position and slide base into locked position (*Figs. 2 and 2a*). Verify that base is fully locked into reclined position (*Fig. 1*).

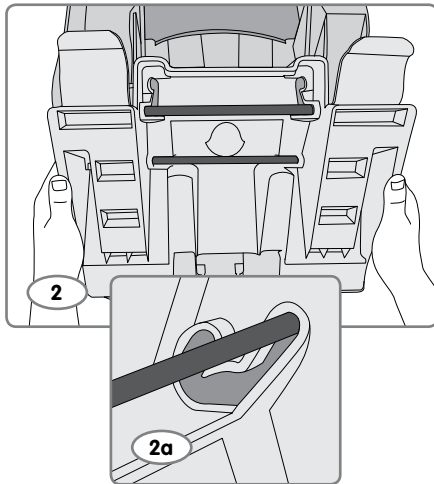
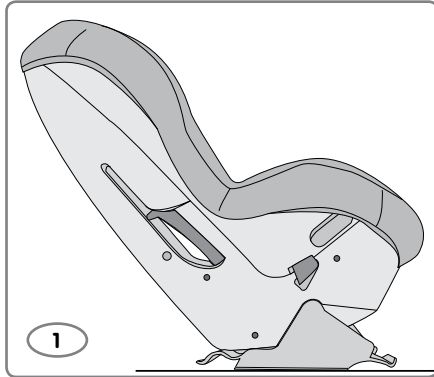

Using the Restraint

Upright Position

Use the forward-facing, upright position with children weighing between 20 pounds (9 kg) and 55 pounds (25 kg) (*Fig. 1*).

WARNING

- Always use in upright position in forward-facing mode.
- The American Academy of Pediatrics recommends rear-facing until at least 1 year of age and 20 pounds.

1. To adjust the restraint to the upright position, turn the restraint upside down so the base is facing up. With both hands, pull up on the base to disengage the rods. Pull base away from shell, then rotate to upright position and slide base into locked position (*Figs. 2 and 2a*). Verify that base is fully locked into upright position (*Fig. 1*).

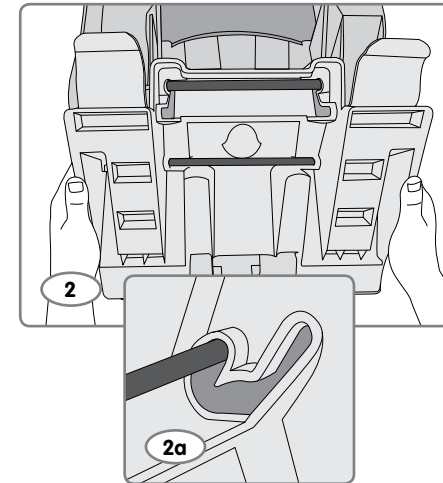
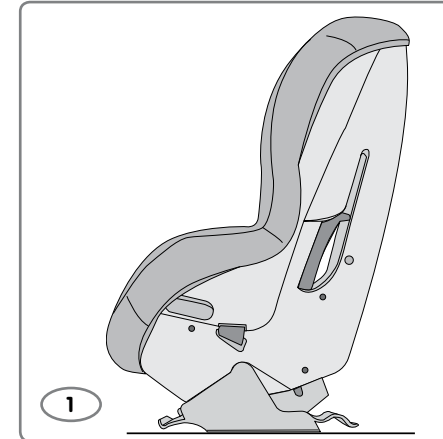

Using the Restraint

Check Harness Height

1. Place child in restraint, then secure harness (see *Secure Your Child in the Restraint*, pages 8 and 9).
2. Observe where the harness is positioned on the child. Rear-facing harness straps should be located in the nearest slot at or below the child's shoulder. Forward-facing harness straps must be located at or above the child's shoulder (**Fig. 1**).
3. If harness height is correct, continue using child restraint without adjustment. If harness height requires adjustment, refer to *Harness Height Adjustment* on page 13.



Rear-Facing

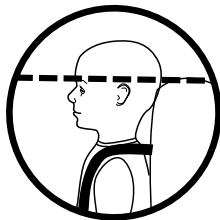

Forward-Facing

1

Weight Range

Rear-Facing
5-33 lbs. (2.3-15 kg)

Forward-Facing
20-55 pounds (9-25 kg)

Maximum Height

Rear-Facing

The child is too tall when the top of the head is 1 inch from the top of the restraint.

Forward-Facing

The child is too tall when the tops of ears are above the top of the restraint or height exceeds 49 inches (124 cm).

Using the Restraint

Harness Height Adjustment

1. To loosen the harness, lift the harness adjuster lever and pull the harness straps forward (**Fig. 1**).

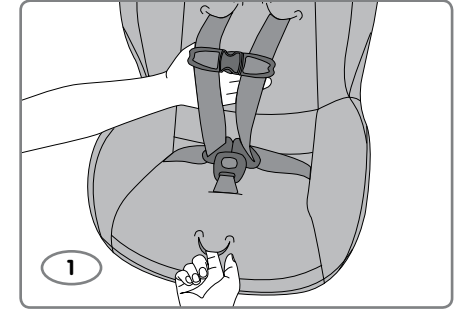

2. At the back of the restraint, unhook the harness straps from the yoke (**Fig. 2**).
3. Pull straps through the shell and cover.

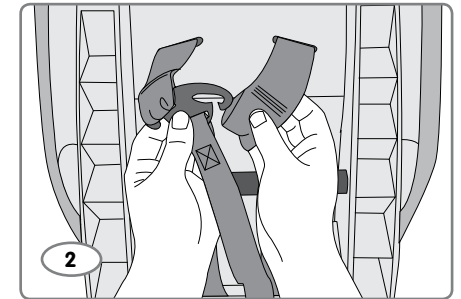

4. Thread the harness straps through slots in shell at the new height (**Fig. 3**).
5. Reattach harness straps to the yoke (**Fig. 2**).
6. Pull harness adjuster strap to tighten the harness.

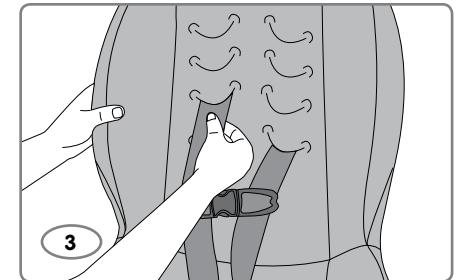

IMPORTANT! Verify that both straps are threaded at the same height and are not twisted.

Vehicle Safety Belts

NOTE: The information in this section applies only to installation with vehicle belts.

IMPORTANT! *Vehicle seats and safety belts differ from vehicle to vehicle. Refer to your vehicle owner's manual for specific information about the vehicle safety belts and their use with child restraints. Some vehicles have no seating positions which are compatible with this child restraint, or any other child restraint. If in doubt, contact the vehicle manufacturer for assistance.*

The following types of vehicle belts are not compatible with this child restraint (**Fig. 1**).

- Front vehicle belts with top or bottom anchorage points in the door.
- Motor-driven automatic vehicle belts.
- Lap-shoulder belts that have separate retractors for the shoulder section and the lap section in which the lap section retractor does not lock without the use of a heavy-duty belt shortening clip.
- 2-point lap belt Emergency Locking Retractor (ELR) vehicle belts without the use of a belt shortening clip.
- Lap-shoulder ELR vehicle belts without the use of the provided locking clip.

The owner's manual for your vehicle will have information on the types of vehicle belts in your vehicle. If your belt type is listed above, select another seating position or use Lower Anchors and Tethers for Children (LATCH) installation.

This child restraint can fit securely in most vehicles using the existing vehicle belts. However, some vehicle designs prevent a secure fit of the child restraint due to the position of the vehicle belt lower anchorage points.

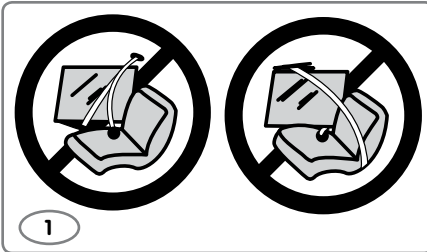

WARNING

Never use the locking clip provided with this restraint in place of a heavy-duty belt shortening clip. Refer to your vehicle owner's manual for specific information.

Vehicle Seating Positions

WARNING

- Forward-facing vehicle seats must be used with this child restraint. Side-facing or rear-facing seats cannot be used.
- Do not place a child restraint in the front seat of a vehicle with a passenger air bag unless the air bag is turned off. Death or serious injury can occur. The back seat is the safest place for children under 12 years of age.

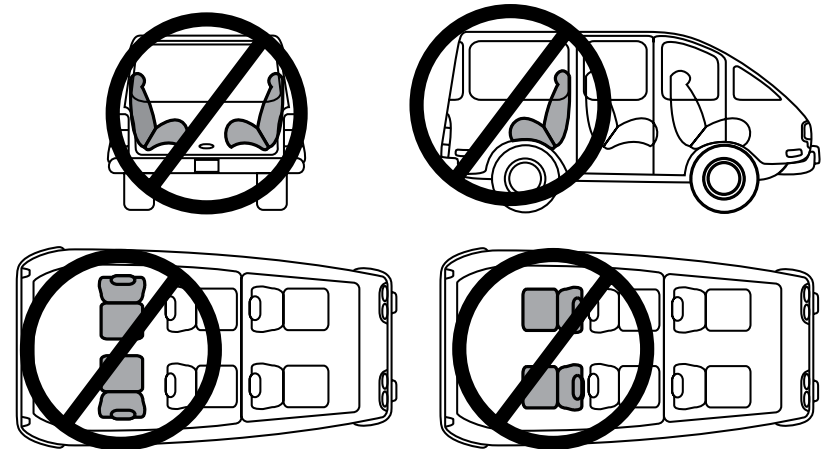

Rear-Facing Installation

LATCH Installation

Figure 1 illustrates a typical rear-facing LATCH installation.

⚠ WARNING

Always use in reclined position in rear-facing mode. See page 10.

IMPORTANT! Verify that your vehicle is equipped with lower anchors. If lower anchors are not installed, you must use vehicle belt installation methods (see pages 18–23).

1. Lift up cover from seat and remove lower hook strap and lower hooks from storage slots (**Fig. 2**). Route one hook through each rear-facing belt path (**Fig. 3**). Replace cover.
2. With the restraint in the reclined position, place it rear-facing in the vehicle seat.
3. Press and hold the lower adjuster release button, then pull to lengthen lower hook strap to full length.
4. Verify that the lower hook strap is not twisted, then attach the left lower hook to left lower anchor in desired seating position (**Figs. 4 and 4a**). Pull on lower hook to confirm attachment to lower anchor.
5. Verify that the lower hook strap is not twisted, then attach the right lower hook to right lower anchor in desired seating position. Pull on lower hook to confirm attachment to lower anchor.

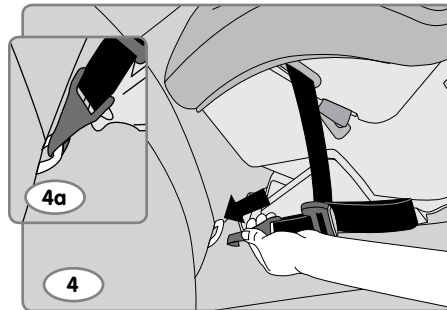
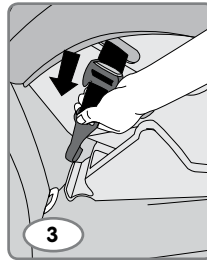
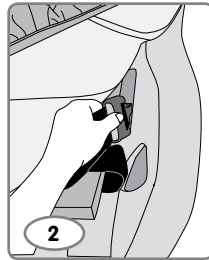
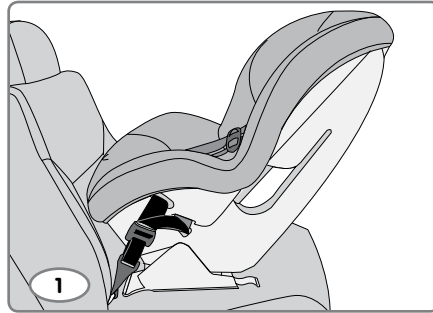

Rear-Facing Installation

6. Push the restraint firmly into the vehicle seat and pull the lower hook strap tight (**Fig. 5**).
7. Verify that all connections are secure and the restraint is stable. A secure restraint should allow no more than 1 inch of side-to-side or forward movement at the belt path (see “Check Buckle Position” on page 30).

IMPORTANT! When correctly reclined, the red line on the shell will be level with the ground, and the back angle of the child restraint should be approximately 45°. If there is a problem achieving the back angle, place a rolled towel under the front of the base to help level the restraint (**Fig. 6**).

⚠ WARNING

Only raise base as described above. Do not raise the base off of the front edge of vehicle seat; doing so will reduce the protection for your child.

LATCH Removal

1. Press button on lower adjuster to loosen lower hook strap (**Fig. 7**).
2. Press on tab to release hook from lower anchor.

IMPORTANT! When not in use, always store the lower hooks in storage slots under cover (see page 16, **Fig. 2**).

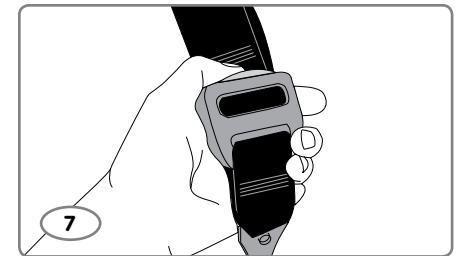
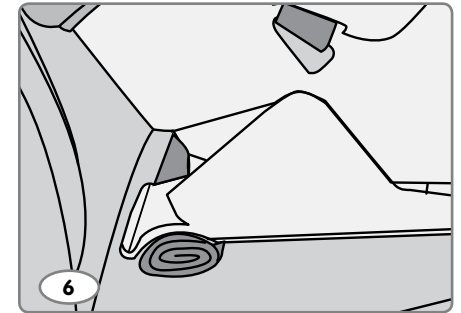
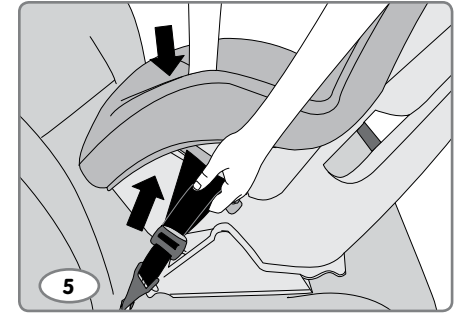

Rear-Facing Installation

Locking Lap-Shoulder Belt Installation

Figure 1 illustrates a typical rear-facing installation using the vehicle's locking lap-shoulder belt.

WARNING

Always use in reclined position in rear-facing mode. See page 10.

IMPORTANT! When installing the restraint with vehicle belts, store the lower books in storage slots under cover (see page 16, Fig. 2).

1. With the restraint in the reclined position, place it rear-facing in the vehicle seat. Lift up the seat cover to expose the rear-facing belt path.
2. Pull to fully extend vehicle lap-shoulder belt. With shoulder and lap portion of vehicle seat belt together, route through the rear-facing belt slot, under the buckle strap and through the other rear-facing slot (**Fig. 2**).
3. Verify that the vehicle belt is not twisted, then buckle (**Fig. 3**). Pull on the vehicle belt to make sure it is securely buckled.

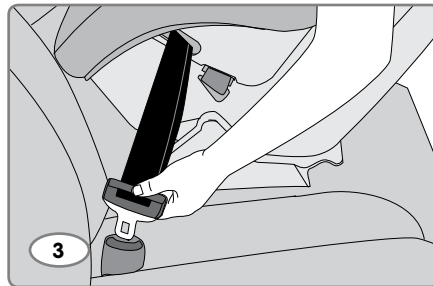
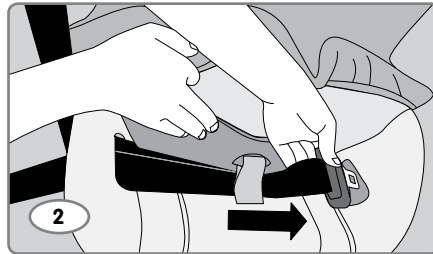
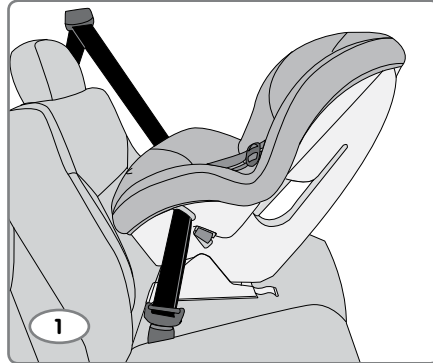

Rear-Facing Installation

4. Push the restraint firmly into the vehicle seat, while removing slack from the vehicle lap-shoulder belt (**Fig. 4**).
5. Verify that all connections are secure and the restraint is stable. A secure restraint should allow no more than 1 inch of side-to-side or forward movement at the belt path (see "Check Buckle Position" on page 30).

IMPORTANT! When correctly reclined, the red line on the shell will be level with the ground, and the back angle of the child restraint should be approximately 45°. If there is a problem achieving the back angle, place a rolled towel under the front of the base to help level the restraint (**Fig. 5**).

WARNING

Only raise base as described above. Do not raise the base off of the front edge of vehicle seat; doing so will reduce the protection for your child.

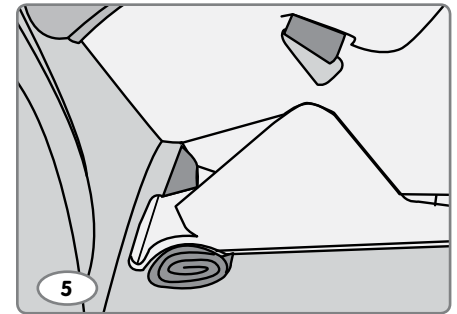
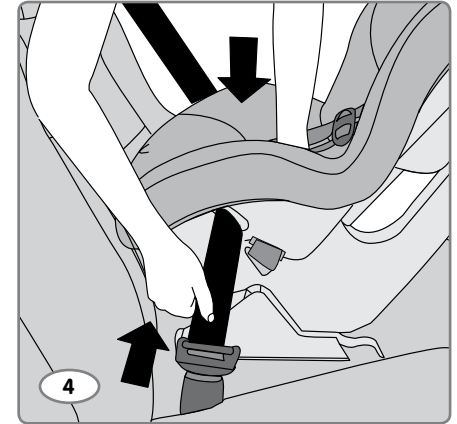

Rear-Facing Installation

Non-Locking ELR Lap-Shoulder Belt Installation Using a Locking Clip

Figure 1 illustrates a typical rear-facing installation using the vehicle's non-locking lap-shoulder belt and a locking clip.

WARNING

Always use in reclined position in rear-facing mode. See page 10.

IMPORTANT! When installing the restraint with vehicle belts, store the lower hooks in storage slots under cover (see page 16, Fig. 2).

WARNING

Do not install this restraint using a non-locking ELR vehicle belt unless a locking clip is used.

1. Remove the locking clip from the user guide storage bag. With the restraint in the reclined position, place it rear-facing in the vehicle seat. Lift up the seat cover to expose the rear-facing belt path.
2. Pull to fully extend vehicle lap-shoulder belt. With shoulder and lap portion of vehicle seat belt together, route through the rear-facing belt slot, behind the buckle strap and through the other rear-facing slot (Fig. 2).
3. Verify that the vehicle belt is not twisted, then buckle (Fig. 3). Pull on the vehicle belt to make sure it is securely buckled.

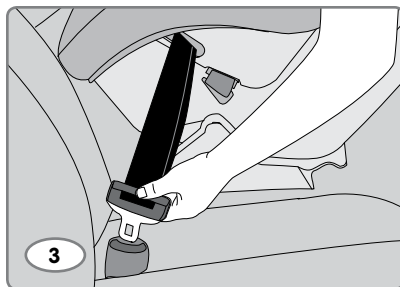
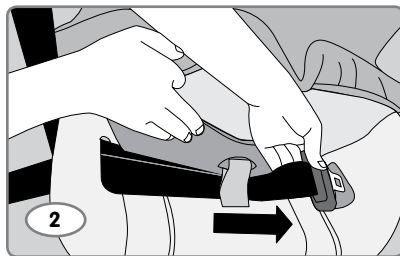
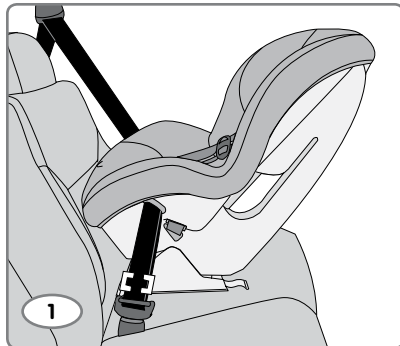

Rear-Facing Installation

4. Push restraint firmly into the vehicle seat, while removing slack from the vehicle lap-shoulder belt (Fig. 4).
5. Hold the lap and shoulder belts together behind the latch plate and unbuckle (Fig. 5).
6. Thread the locking clip onto both belts (Fig. 6), placing it within 1/2 inch of the latch plate (Fig. 7).
7. Buckle the belt again. The belt should be tight around the restraint. If not, remove the locking clip and repeat Steps 2-7.
8. Verify that all connections are secure and the restraint is stable. A secure restraint should allow no more than 1 inch of side-to-side or forward movement at the belt path (see "Check Buckle Position" on page 30).

IMPORTANT! When correctly reclined, the red line on the shell will be level with the ground and the back angle of the child restraint should be approximately 45°. If there is a problem achieving the back angle, place a rolled towel under the front of the base to help level the restraint (see page 19, Fig. 5).

WARNING

Only raise base as described above. Do not raise the base off of the front edge of vehicle seat; doing so will reduce the protection for your child.

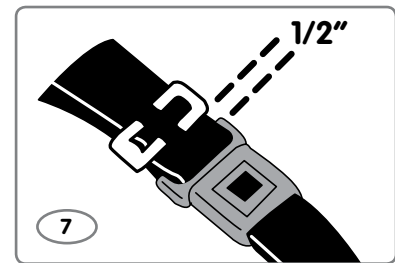
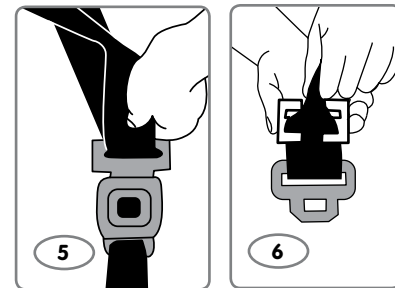
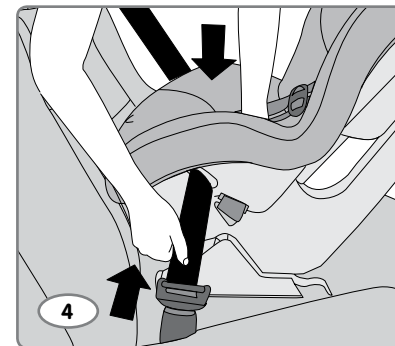

Rear-Facing Installation

Lap Belt Installation

Figure 1 illustrates a typical rear-facing vehicle lap belt installation.

WARNING

Always use in reclined position in rear-facing mode. See page 10.

IMPORTANT! When installing the restraint with vehicle belts, store the lower books in storage slots under cover (see page 16, Fig. 2.)

1. With the restraint in the reclined position, place it rear-facing in the vehicle seat. Lift up the seat cover to expose the rear-facing belt path.
2. Pull to fully extend vehicle lap belt. Route through rear-facing belts slot, behind the buckle strap and through the other rear-facing slot (Fig. 2).
3. Verify that the vehicle belt is not twisted, then buckle (Fig. 3). Pull on the vehicle belt to make sure it is securely buckled.

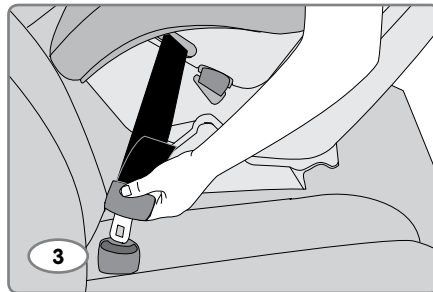
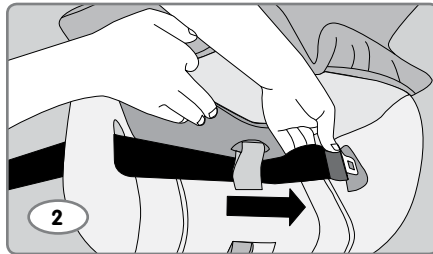
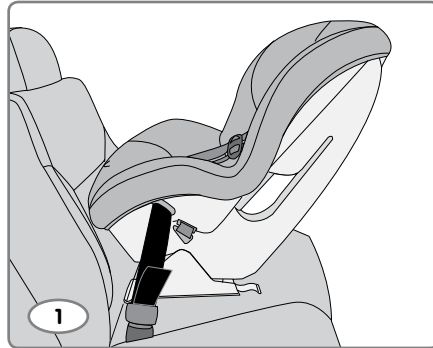

Rear-Facing Installation

4. Push the restraint firmly into the vehicle seat while removing slack from the vehicle lap belt (Fig. 4).
5. Verify that all connections are secure and the restraint is stable. A secure restraint should allow no more than 1 inch of side-to-side or forward movement at the belt path (see "Check Buckle Position" on page 30).

IMPORTANT! When correctly reclined, the red line on the shell will be level with the ground, and the back angle of the child restraint should be approximately 45°. If there is a problem achieving the back angle, place a rolled towel under the front of the base to help level the restraint (Fig. 5).

WARNING

Only raise base as described above. Do not raise the base off of the front edge of vehicle seat; doing so will reduce the protection for your child.

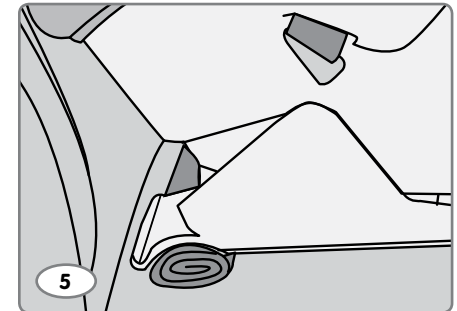
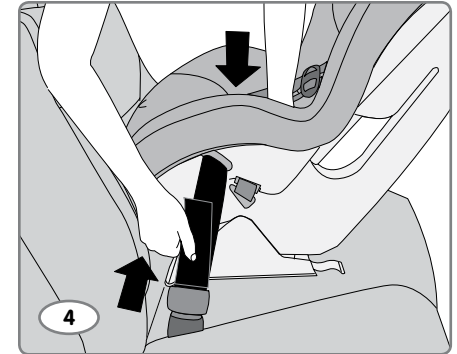

Forward-Facing Installation

LATCH Installation

Figure 1 illustrates a typical forward-facing LATCH installation.

WARNING

Always use in upright position in forward-facing mode. See page 11.

IMPORTANT! Verify that your vehicle is equipped with lower anchors. If lower anchors are not installed, you must use vehicle belt installation methods (see pages 26–29).

1. Lift up cover from seat and remove the lower hook strap and lower hooks out of the rear-facing belt path OR from the storage slots (**Fig. 2**). Pull hooks through forward-facing path (**Fig. 3**).
2. Press and hold the lower adjuster release button, then pull to lengthen lower hook strap to full length.
3. Verify that the lower hook strap is not twisted, then attach the left lower hook to left lower anchor in desired seating position (**Fig. 4**). Pull on lower hook to confirm attachment to lower anchor.
4. Verify that the lower hook strap is not twisted, then attach the right lower hook to right lower anchor in desired seating position. Pull on lower hook to confirm attachment to lower anchor.

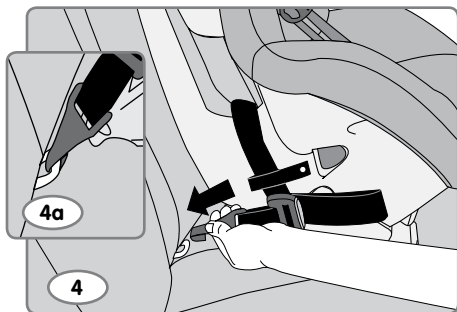
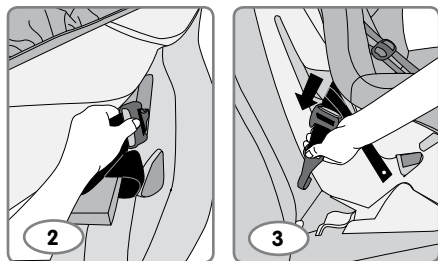
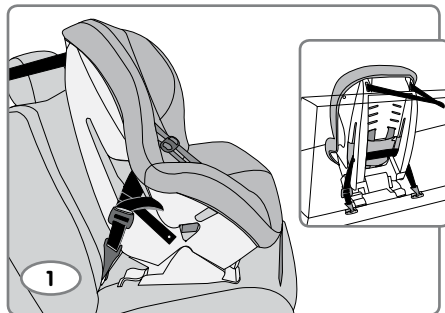

Forward-Facing Installation

5. Kneel on the restraint to push it into the vehicle seat while pulling the lower hook strap tight (**Fig. 5**).
6. Install tether as instructed on pages 32–33.
7. Verify that all connections are secure and the restraint is stable. A secure restraint should allow no more than 1 inch of side-to-side or forward movement at the belt path.

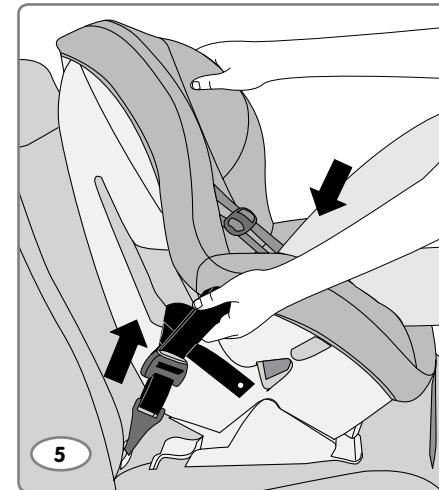

LATCH Removal

1. Press button on lower adjuster to loosen lower hook strap (**Fig. 6**).
2. Press on tab to release hook from lower anchor.
3. Disconnect the tether.

IMPORTANT! When not in use, always store the lower hooks in storage slots under cover (see page 16, Fig 2).

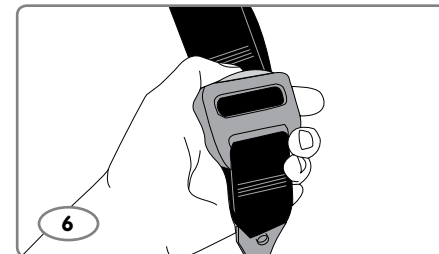

Forward-Facing Installation

Locking Lap-Shoulder Belt Installation

Figure 1 illustrates a typical forward-facing installation using the vehicle's locking lap-shoulder belt.

WARNING

Always use in upright position in forward-facing mode. See page 11.

IMPORTANT! When installing the restraint with vehicle belts, store the lower hooks in storage slots under cover (see page 16, Fig. 2).

1. With the restraint in the upright position, place it forward-facing in the vehicle seat.

IMPORTANT! Installation can be improved by using the tether (see pages 32-33).

2. Pull to fully extend the vehicle lap-shoulder belt. Hold the shoulder and lap portion of the vehicle belt together and route through the forward-facing belt path.
3. Verify that the vehicle belt is not twisted, then buckle (**Fig. 2**). Pull on the vehicle belt to make sure it is securely buckled.
4. Kneel on the restraint to push it into the vehicle seat while removing slack from the vehicle lap-shoulder belt (**Fig. 3**).
5. Verify that all connections are secure and the restraint is stable. A secure restraint should allow no more than 1 inch of side-to-side or forward movement at the belt path (see "Check Buckle Position" on page 30).

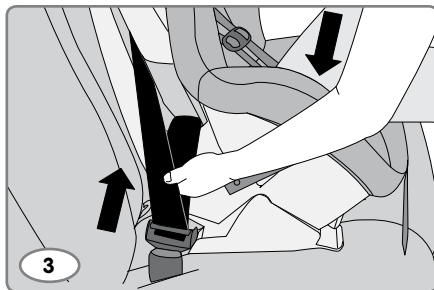
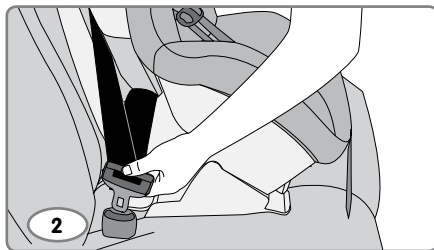
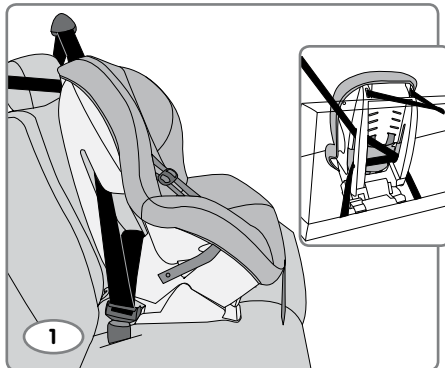

Forward-Facing Installation

Non-Locking ELR Lap-Shoulder Belt Installation Using a Locking Clip

Figure 1 illustrates a typical forward-facing installation using the vehicle's non-locking lap-shoulder belt and a locking clip.

WARNING

Always use in upright position in forward-facing mode. See page 11.

IMPORTANT! When installing the restraint with vehicle belts, store the lower hooks in storage slots under cover (see page 16, Fig. 2).

WARNING

Do not install this restraint using a non-locking ELR vehicle belt, unless a locking clip is used.

1. Remove the locking clip from the user guide storage bag. With the restraint in the upright position, place it forward-facing in the vehicle seat.

IMPORTANT! Installation can be improved by the using the tether (see pages 32-33.)

2. Pull to fully extend the vehicle lap-shoulder belt. Hold the shoulder and lap portion of the vehicle belt together and route through the forward-facing belt path.
3. Verify that the vehicle belt is not twisted, then buckle (**Fig. 2**). Pull on the vehicle belt to make sure it is securely buckled.

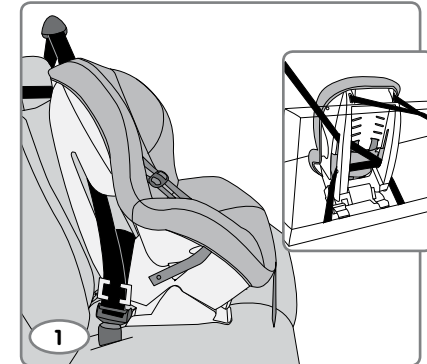

Forward-Facing Installation

4. Kneel on the restraint to push it into the vehicle seat while removing slack from the vehicle lap-shoulder belt (**Fig. 3**).
5. Hold the lap and shoulder belts together behind the latch plate and unbuckle (**Fig. 4**).
6. Thread the locking clip onto both belts (**Fig. 5**), placing it within 1/2 inch of the latch plate (**Fig. 6**).
7. Buckle the belt again. The belt should be tight around the restraint. If not, remove the locking clip and repeat Steps 2-7.
8. Verify that all connections are secure and the restraint is stable. A secure restraint should allow no more than 1 inch of side-to-side or forward movement at the belt path. See “Check Buckle Position” on page 30.

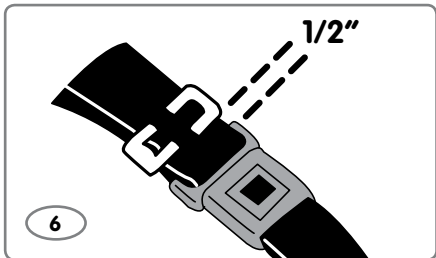
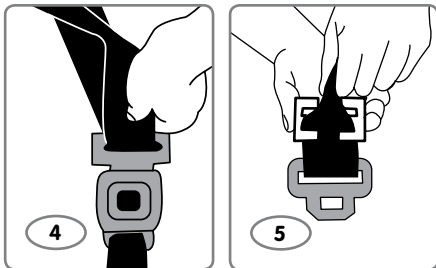
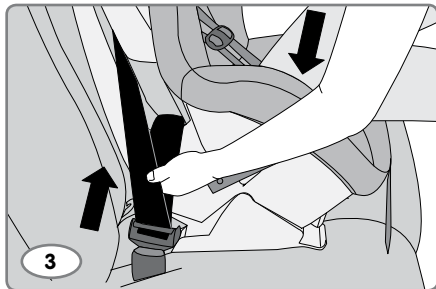

Forward-Facing Installation

Lap Belt Installation

Figure 1 illustrates a typical forward-facing vehicle lap belt installation.

WARNING

Always use in upright position in forward-facing mode. See page 11.

IMPORTANT! When installing the restraint with vehicle belts, store the lower hooks in storage slots under cover (see page 16, Fig. 2).

1. With the restraint in the upright position, place it forward-facing in the vehicle seat.
IMPORTANT! Installation can be improved by using the tether (see pages 32-33).
2. Pull the vehicle belt out, then pass it through both forward-facing belts slots.
3. Verify that the vehicle belt is not twisted, then buckle (**Fig. 2**). Pull on the vehicle belt to make sure it is securely buckled.
4. Kneel on the restraint to push it into the vehicle seat while removing slack from the vehicle belt (**Fig. 3**).
5. Verify that all connections are secure and the restraint is stable. A secure restraint should allow no more than 1 inch of side-to-side or forward movement at the belt path (see “Check Buckle Position” on page 30).

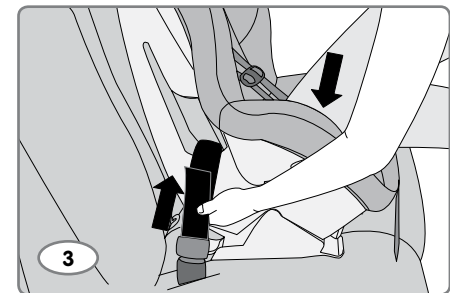
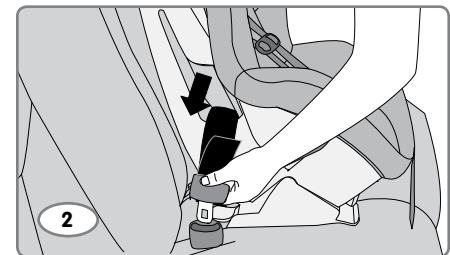
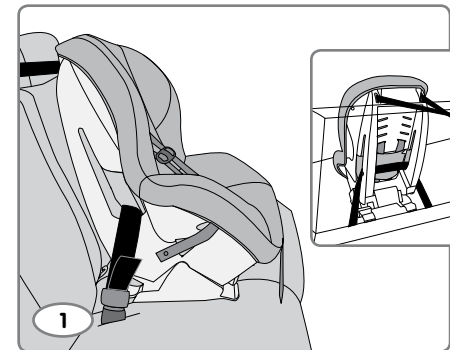

Check Buckle Position

If the buckle is touching the vehicle belt path opening (**Figs. 1 and 2**) after the vehicle belt is tightened, move the child restraint to another seating position in the vehicle to achieve the correct position (**Figs. 3 and 4**). Contact your vehicle manufacturer for assistance if you cannot achieve the correct buckle position.

IMPORTANT! Check that the child restraint is secure before each trip.

Rear-Facing

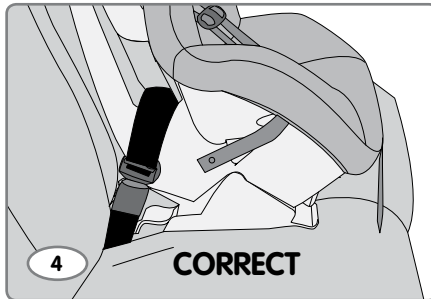
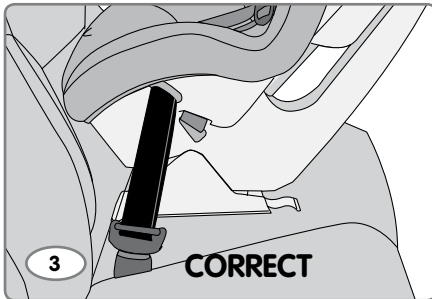
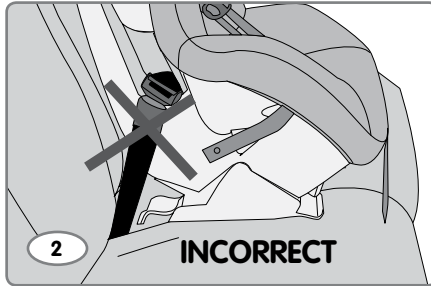
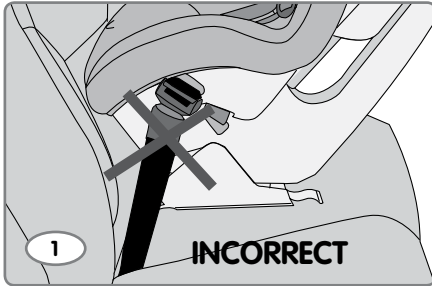

Installation in Aircraft

This child restraint is certified for aircraft use. Most airlines in the U.S. and Canada will allow the use of a child restraint if it is labeled as an approved child restraint for airline use and fits properly on the plane. Contact the airline about their policy prior to traveling.

Rear-Facing Installation

For rear-facing aircraft installation (**Fig. 1**), see *Lap Belt Installation* on pages 22 and 23.

Forward-Facing Installation

For forward-facing aircraft installation (**Fig. 2**), see *Lap Belt Installation* on page 29.

NOTE:

- Place the child restraint next to a window to avoid blocking the aisle.
- If the aircraft lap belt is too short, ask the flight attendant for a belt extender.

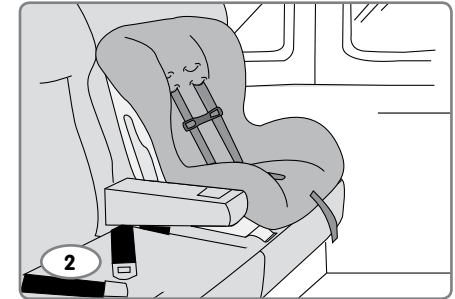
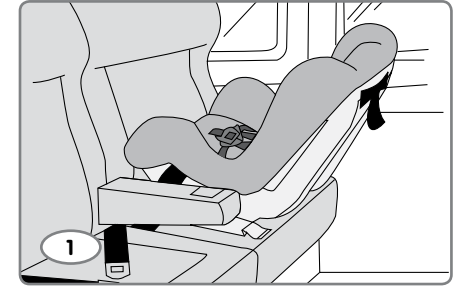

Using the Tether

WARNING

- When using the restraint in forward-facing position, attach the tether only to tether anchors identified by the vehicle manufacturer as tether anchorage points. Use of other locations is not approved or permitted.
- The manufacturer recommends that the tether be used in forward-facing mode. Using the tether will improve the stability of the child restraint and reduce the risk of injury.
- If the vehicle does not currently have a tether anchor attachment, refer to the vehicle owner's manual or contact the vehicle manufacturer for assistance.
- If tether anchorage is not available, do not modify the vehicle without advice from the vehicle manufacturer.
- Do not hook the tether to a vehicle seat mechanism!
- The back angle of the child restraint should be approximately 45° when properly installed in the rear-facing position.

Using the Tether

Before installing restraint:

1. Remove tether components from pouch on rear of restraint.
2. Lift tether adjuster release tab, then pull to extend tether strap into a V-shape.
3. Loosely attach the tether to an approved anchor point using the tether hook located on the tether strap (*Fig. 1*).
4. Install restraint as described in the appropriate installation section on pages 16–29.

After installing restraint:

5. Pull the tether strap to remove all slack.
6. Verify that there is tension in the tether strap and that child restraint is properly secured.

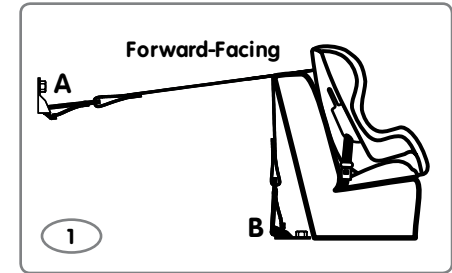

Care and Maintenance

Cover Removal

1. Loosen the harness by lifting the harness adjuster located in the front of the restraint, and pull the harness straps forward.
2. Unhook the harness straps from the yoke on the back of restraint.
3. Unbuckle harness from the buckle.
4. Pull upper harness straps through the shell and cover to the top of the restraint.
5. Gently remove the upper portion of the cover. Be careful not to damage the energy-absorbing foam.
6. Pull the lower harness straps, buckle tongues, chest clip and buckle through the slots in the cover.
7. Remove cover from the restraint.

WARNING

- Do not take apart or attempt to take apart the harness. It is unnecessary and dangerous to do so.
- Never remove the buckle tongues from the harness. They cannot be reattached after removal.

Cover Replacement

To replace the cover, reverse removal directions above. Make sure that the harness straps are threaded through the chest clip and that the harness is not twisted.

Care and Maintenance

Cleaning the Cover

- Hand wash, using cold water and mild soap.
- Line dry to prevent cover from shrinking.
- Do not bleach, machine wash, machine dry, or iron.

Cleaning the Shell and Harness

- Brush away loose debris, using a soft-bristle brush.
- Sponge clean, using warm water and mild soap.
- Towel dry.
- Do not use solvents, abrasive cleaners, or bleach. Do not machine wash, machine dry, or disassemble the harness.

Cleaning the Harness Adjuster

WARNING

Periodically check the adjuster area to be sure it is clean and free of food, coins, dirt, and other objects. If debris is present, it must be removed to prevent interference with the adjuster mechanism.

- Brush away loose debris, using a soft-bristle brush.
- Sponge clean, using warm water and mild soap.
- Towel dry.
- Do not use solvents or abrasive cleaners, or disassemble the harness.

Care and Maintenance

Buckle Removal and Replacement

Buckle Removal

1. Turn the restraint upside down.
2. Locate metal buckle strap retainer on the underside of the restraint.
3. Pull retainer away from child restraint to loosen.
4. Turn the retainer so that the short side will go up through the slot in the restraint shell to the upper side of the restraint.
5. Pass the retainer through the slot in cover to remove buckle from restraint.

Buckle Replacement

1. Locate the buckle slot.
2. Turn the buckle retainer so that the short side will go through the slot in the cover and restraint shell (**Fig. 1**).
3. Pull buckle away from restraint until tight, then verify that the strap is not twisted and the release button is facing outward.
4. Make sure the buckle retainer lies flat against the restraint shell.

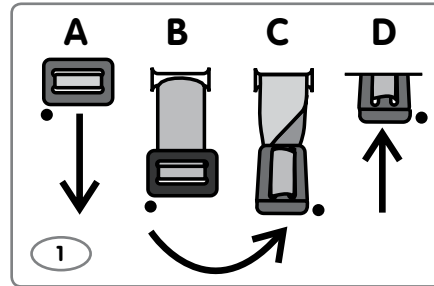

Care and Maintenance

Cleaning the Buckle

If a child eats and drinks while in the restraint, the buckle may need to be periodically checked and cleaned of any accumulated debris or dried liquids.

1. After removing the buckle (see *Buckle Removal*, page 36), thoroughly rinse, using warm water (**Fig. 1**).
2. Soak, overnight if possible, using warm water to loosen hardened drinks or food.
3. Test the buckle by fastening and unfastening until a “click” is heard after inserting each buckle tongue (**Fig. 2**). If a “click” is not heard, repeat cleaning procedure.
4. Towel dry.
5. Do not lubricate, use solvents, abrasive cleaners, soap or household detergents.

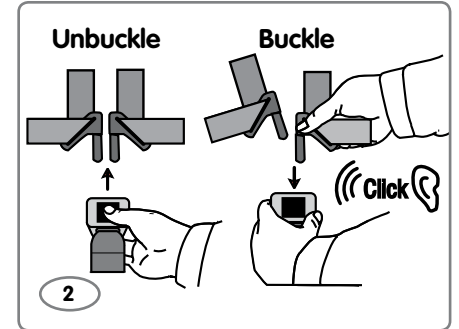
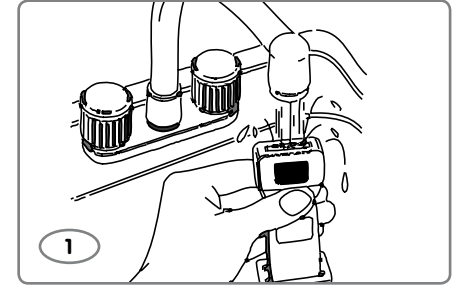

Warranty

This child restraint was manufactured by Britax Child Safety, Inc. The manufacturer warrants this product to the original retail purchaser as follows:

LIMITED ONE-YEAR WARRANTY

This product is warranted against defective materials or workmanship for one year from the date of original purchase. Proof of purchase is required. The exclusive remedy for this warranty is that the manufacturer will, at its option, provide repair or replacement components for this product or refund the original purchase price of the product. The manufacturer reserves the right to discontinue or change fabrics, parts, models or products, or to make substitutions.

To make a claim under this warranty, contact Consumer Services at 1-866-204-1665 or write to us at Britax Child Safety, Inc., 13501 South Ridge Drive, Charlotte, NC 28273. Include proof of purchase with your correspondence.

PLEASE COMPLETE AND MAIL THE OWNER REGISTRATION CARD WITHIN (30) DAYS OF PURCHASE.

WARRANTY LIMITATIONS

This warranty does not include damages which arise from negligence, misuse or use not in accordance with the product instruction.

The use of third-party covers, inserts, toys, accessories or tightening devices is not approved by the manufacturer. Their use could cause this restraint to fail Federal Safety Standards or perform worse in a crash. Their use automatically voids this warranty.

LIMITATION OF DAMAGES

The warranty and remedies as set forth above are exclusive and in lieu of all others, oral or written, express or implied. In no event will the manufacturer, or the retailer selling this product, be liable for any damages, including incidental or consequential damages, arising out of the use or inability to use this product.

LIMITATIONS OF WARRANTIES AND OTHER WARRANTY TERMS AND STATE LAWS

Any implied warranties, including implied warranties of merchantability and fitness for a particular purpose, shall be limited to the duration and terms of the express written warranty. Some states do not allow limitations on how long an implied warranty lasts or the exclusion or limitation of incidental or consequential damages, so the above limitations may not apply. This warranty gives you specific legal rights, and you may have other rights, which vary from state to state. Neither the manufacturer nor the retailer selling this product authorizes any person to create for it any other warranty, obligation or liability in connection with this product.