

# OPERATOR'S MANUAL

# 651615-X

INCLUDING: OPERATION, INSTALLATION & MAINTENANCE

RELEASED: 2-25-95  
REVISED: 6-21-10  
(REV. C)

## SINGLE POST LIFT/RAM

For use with 5 Gallon Drums (Tapered or Straight)



**READ THIS MANUAL CAREFULLY BEFORE INSTALLING,  
OPERATING OR SERVICING THIS EQUIPMENT.**

### THIS MANUAL COVERS THE FOLLOWING MODELS

MODEL	TYPICAL PUMP APPLICATION
651615	3" & 4-1/4" AIR MOTORS (TIE ROD PUMPS)

### SERVICE KITS

Rebuild Kit for E512LM Valve - 116722

Repair Kit for 127112-000 Miniature Regulator - 104158

BASE DIMENSIONS: 20" SQUARE (508 mm)  
HEIGHT: LOWERED 36-3/4" (.9m), RAISED 56-1/4" (1.7 m)

### GENERAL DESCRIPTION

The ARO Model 651615-X Single Post Lift/Ram uses a 3-1/2" air-powered cylinder which is welded to a heavy gauge base. It is normally used to raise and lower a fluid handling pump and follower in and out of standard 5-gallon drum or when used as a ram it can force high viscosity flowable material into the pump inlet.

When properly secured, this unit has the ability to raise a pump to clear a standard 5-gallon drum. The operator is then able to easily remove the pump from a pail.

This Lift/Ram uses a hand lever 4-way control valve which controls the air necessary to raise and lower the lift. This unit includes an auxiliary manual air valve which is used to supply a controlled amount of air pressure to the bottom of the follower plate. When the Control Valve is in the "UP" position a small amount of air pressure applied under the follower plate will help to raise the follower plate, pump and lift by relieving the vacuum. See Page 3.

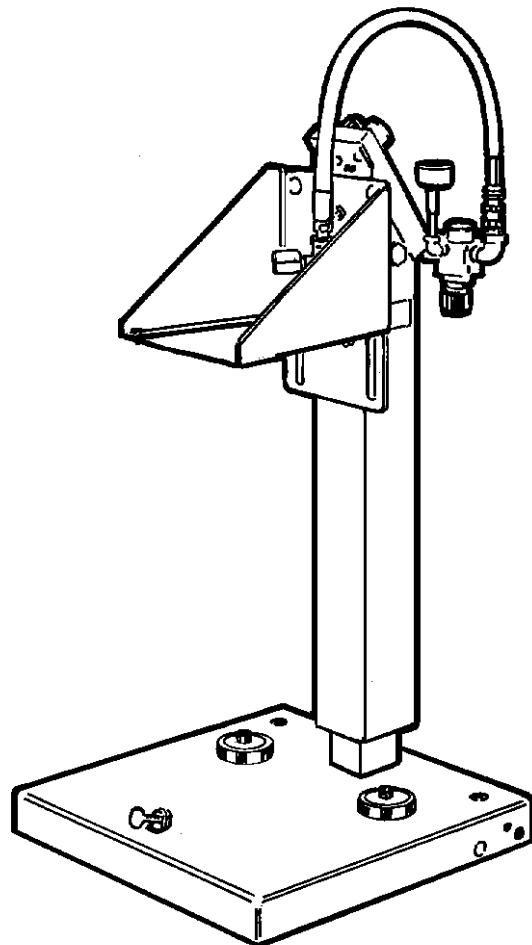

651615  
SINGLE POST LIFT

## OPERATING AND SAFETY PRECAUTIONS

- ◇ Read and heed all Warnings, Cautions, and Safety Precautions before operating.
- ◇ Use only genuine ARO replacement parts to assure compatible pressure rating and longest service life.



**Shock hazard.** Striking electrical fixtures can cause injury.

Keep the area overhead clear of electrical devices.

**⚠ WARNING PREVENT ELECTRIC SHOCK.** Be certain the area above the lift is clear of electrical fixtures, devices and wiring. Examine the working area and take necessary action to assure adequate clearance for the lift and pump assembly to raise to the fullest limit and function properly.



**Pinch hazard.** Follower can descend quickly causing injury.

Keep hands clear when aligning with container

**⚠ WARNING PINCH HAZARD.** Follower can descend quickly, causing injury. Keep hands clear when aligning with container. In the raising and lowering function the lift could get hung up or the descent could be temporarily restricted. The lift could in some

situations drop suddenly and be hazardous. If the follower plate does not enter the drum properly, DO NOT ATTEMPT TO REPOSITION IT WITH YOUR HANDS; release the downward pressure, raise the lift, realign the drum and restart.

**⚠ WARNING STAND CLEAR.** When raising or lowering the lift keep clear and operate from a safe position.



**Hazardous pressure.** Can result in injury or property damage.

Do not exceed maximum inlet air pressure.

**⚠ WARNING HAZARDOUS PRESSURE.** Do not exceed maximum inlet air pressure of 160 psi (11 bar). Operating lift at higher pressure may cause lift damage and/or personal injury and/or property damage. Do not service or clean pump, hoses or dispensing valve while the system is pressurized.

**⚠ WARNING DO NOT EXCEED DRUM PRESSURE LIMITS.** Know the pressure limitations of the drum and regulate the air pressure within safe limits when supplying air follower plate.

**⚠ CAUTION** Be certain all operators of this equipment have been trained for safe working practices, understand it's limitations, and wear their safety goggles/equipment as required.

## MAJOR COMPONENTS

FIGURE 1

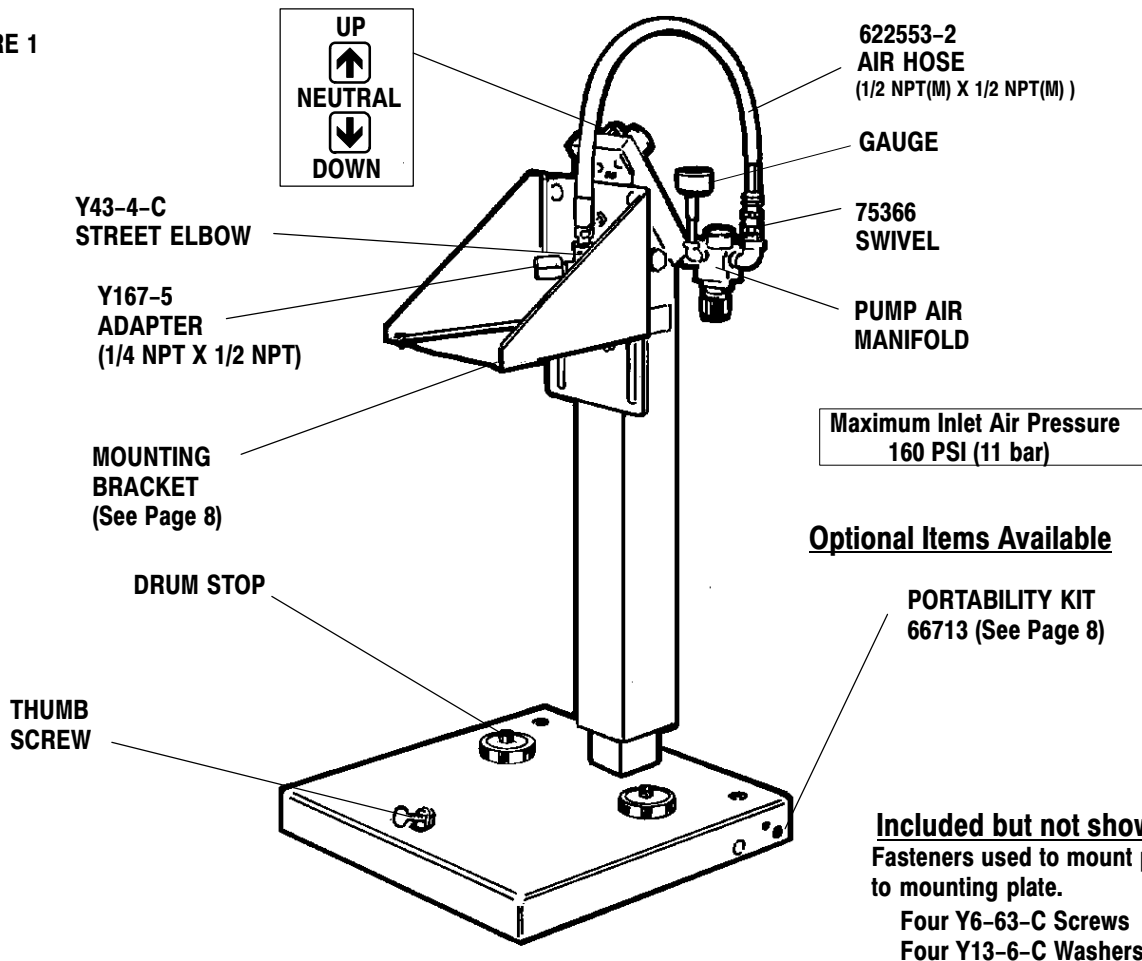

## LIFT/RAM INSTALLATION

**⚠ WARNING** Failure to properly install the lift assembly can result in severe personal injury and property damage. Read the warning on page 2.

1. Establish the desired location for the lift/ram and pay special attention to work area above, this area above the lift must be open, without obstructions and safely away from any electrical devices.
2. Place the pump on the follower plate and align the pump and follower plate on the base and assemble pump to the mounting bracket on the ram.

3. Assemble air hose to air motor inlet.
4. Install the check and follower plate air hose from the Control Valve.
5. Assemble the vent plug to the follower plate.

**NOTE:** The ram was tested at the factory. The unit should be generally checked over for leakage because the fittings on the system may have loosened in shipment.

## OPERATING INSTRUCTIONS

### OPERATING INSTRUCTIONS / INITIAL SETUP PROCEDURE

**⚠ WARNING** STAND CLEAR. When raising or lowering the lift. Read the warning on page 2.

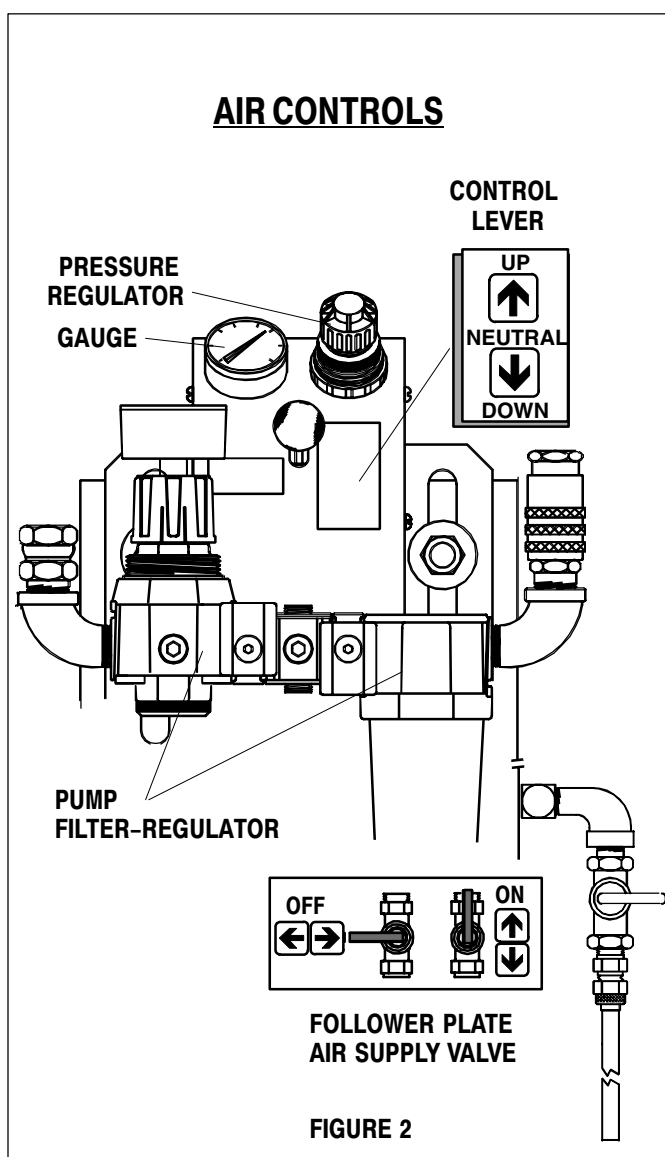

### TO RAISE LIFT, (THE FIRST TIME):

1. Take note of the pump/drum clearance above. Be certain the lift is clear of any objects above. Also refer to OPERATING AND SAFETY PRECAUTIONS found on page 2.
2. Connect the air supply (160 PSI MAX) to the air inlet.
3. Shift the control valve lever to the "UP" position.
4. Raise the lift high enough to clear the height of the drum. Stop the lift upward travel by moving the control valve lever to the (center) "NEUTRAL" position.

### TO RAISE LIFT, (NORMAL OPERATION):

1. Adjust the Follower Plate Air Valve pressure up to approximately 8 psig. DO NO OVERPRESSURIZE THE DRUM to avoid damage. **NOTE:** Air from this valve will only pass when the Control Lever is in the "UP" position.
2. Shift the control valve lever to the "UP" position.
3. Raise the lift high enough to clear the height of the drum. Stop the lift upward travel by moving the control valve lever to the (center) "NEUTRAL" position.

### TO CHANGE DRUM:

**NOTE:** The Control Lever should be in the "NEUTRAL" position.

1. Place a new drum into position.

### TO LOWER LIFT:

**⚠ WARNING** PINCH HAZARD. Follower can descend quickly causing injury. Keep hands clear when aligning with container. Read the warning on page 2.

**NOTE:** Be certain the Follower Plate vent plug has been removed so that the air trapped between the follower and the material is allowed to escape from this vent. Captured air between the follower plate and drum will escape.

**NOTE:** The lift may hesitate momentarily before starting downward, the air pressure inside the post air chamber must decrease before it will begin to descend.

1. Shift the control valve lever to the "DOWN" position and proceed to lower the pump.
2. Replace the vent plug once the material begins to ooze from the vent opening.

**PARTS LIST**

**Single Post Ram/Lift**

ITEM	DESCRIPTION (SIZE IN INCHES)	(QTY)	PART NO.
1	Gauge	(1)	29975
2	Tube 5"	(1)	44632 □
3	Tube 4.75"	(4)	44632 □
4	Screw (1/4-20)	(3)	Y99-45-C
5	Nut (1/4-20)	(3)	Y12-4-C
6	Washer (1/4")	(3)	Y13-4-C
7	Screw (5/8-11)	(2)	Y6-105-C
8	Lockwasher (5/8)	(2)	Y14-625-C
9	Manifold	(1)	92380
10	Panel Nut	(1)	29661
11	Connector	(7)	59688-4
12	Elbow (1/8" NPT)	(1)	Y43-1-C
13	Shut-off Valve	(1)	Y28-2
14	Connector	(1)	Y214-2
15	Tube 2.208 feet	(1)	59675 ○
16	Regulator	(1)	R27241-100
17	1/2" Male Swivel	(1)	75366
18	Elbow (1/2)	(2)	Y43-4-C

ITEM	DESCRIPTION (SIZE IN INCHES)	(QTY)	PART NO.
19	Carriage Bolt (1/2-13)	(4)	Y84-801-C
20	Lockwasher (1/2")	(4)	Y14-816-C
21	Washer (1/2")	(4)	Y13-8-C
22	Nut (1/2-13)	(4)	Y12-8-C
23	Cover	(1)	92375
24	Self Tapping Screw (#8-32)	(4)	Y222-130-C
25	Label	(1)	92449
26	Coupler	(1)	23103-004
27	Connector (1/2 NPT)	(1)	23903-410
28	Filter	(1)	F25241-100
29	Manifold Kit	(1)	104170
□	Bulk Tube-100 Ft.Roll 3/16" O.D.-		59690-104
○	Bulk Tube-100 Ft.Roll 1/4" O.D.-		59675-100
☆	Apply PTFE Tape to threads.		
◇	Apply Anaerobic Pipe Thread Sealant to threads.		

**BASIC SINGLE POST RAM/LIFT  
ASM.**

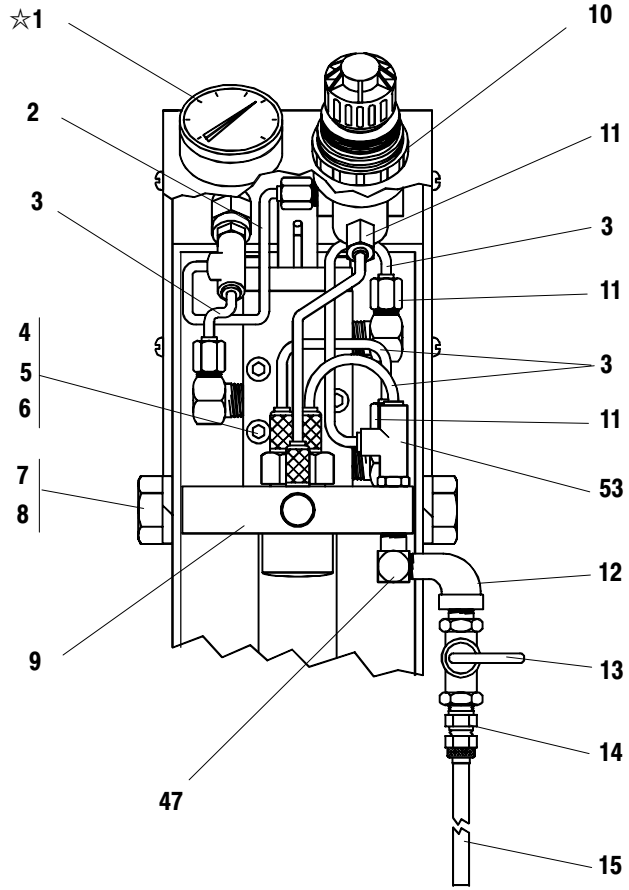

**FIGURE 3**

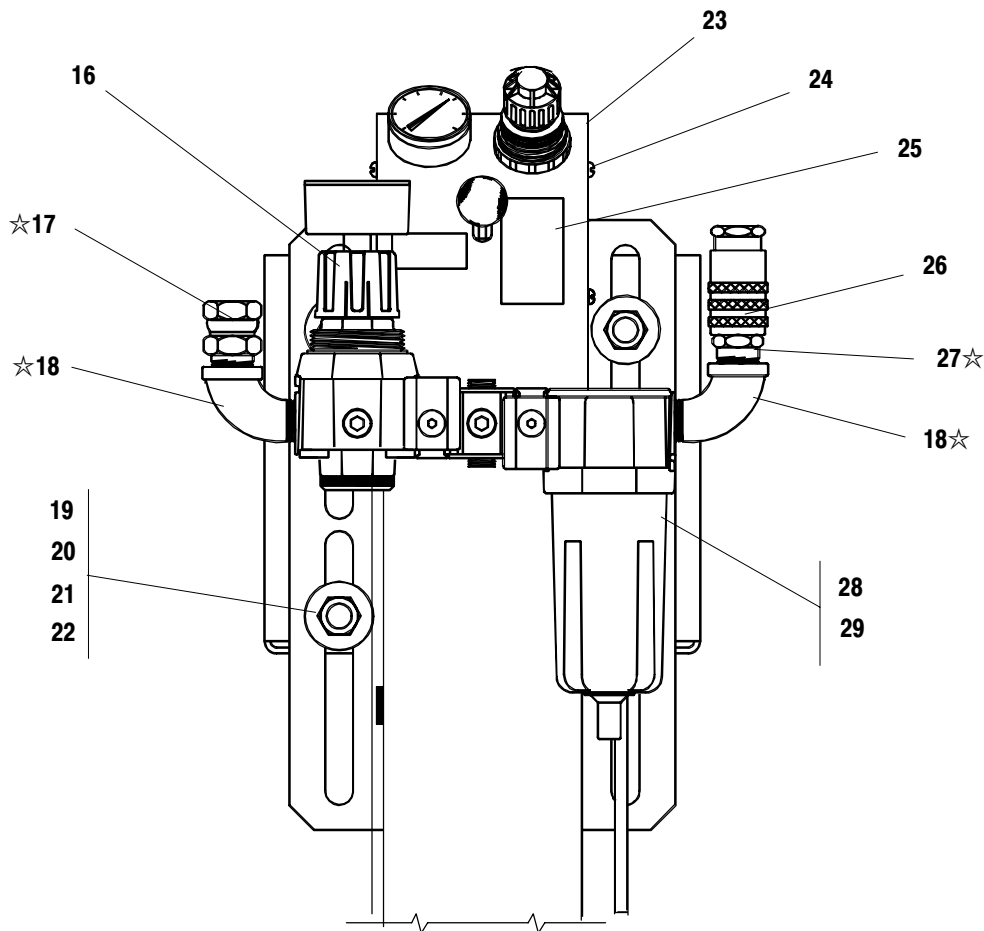

**FIGURE 4**

**PARTS LIST**

**Single Post Ram/Lift**

ITEM	DESCRIPTION (SIZE IN INCHES)	(QTY)	PART NO.
30	Thumb Screw	(1)	Y66-378-C
31	Base	(1)	66558
32	Bucket Stop	(2)	92565
33	Carriage Bolt	(2)	Y84-601-C
34	Nut (3/8-6)	(2)	Y12-6-C
35	Lockwasher	(2)	Y14-616-C
36	Tube	(1)	92378
37	Rod	(1)	92379
38	"O" Ring (3 1/4" O.D.)	(1)	Y325-336
39	Retaining Ring	(1)	90503
40	Plate	(1)	91396
41	Screw	(4)	Y6-42-C
42	Nut (1/4-20)	(4)	Y12-4-C
43	Washer (1/4")	(4)	Y13-4-C
44	Bracket	(1)	93968
45	Male Fitting	(3)	59753-4
46	Elbow	(3)	92388
47	"E" Series 4-Way Valve ■■	(1)	E512LM
48	Adapter	(3)	6045
49	Plug (1/8" NPT)	(1)	Y17-50
50	Washer	(1)	Y13-6-C
51	Spring	(1)	38226

ITEM	DESCRIPTION (SIZE IN INCHES)	(QTY)	PART NO.
52	Air Regulator	(1)	127122-000
53	Hose Coupling	(1)	3249
54	Male Tee Fitting	(2)	59747-4
55	Tubing 5.37	(1)	44632□
56	Plug	(1)	92389
57	"O" Ring (7/8" O.D.)	(1)	Y325-18
58	Gauge	(1)	100067
59	Coupling (1/4 NPT)	(1)	Y43-42-C
60	Nipple (1/4 NPT)	(1)	Y44-11-C
61	Elbow (1/4 NPT)	(1)	Y43-2-C
62	Nipple (1/4 NPT)	(1)	Y44-13-C
63	Retaining Ring	(1)	Y147-200
64	Retaining Washer	(1)	90509
65	Retaining Wiper	(1)	90508
66	Retaining Washer	(1)	90511
67	Unipack Seal	(1)	90507
68	Dowel Pin	(1)	Y148-35
69	Cap & Bearing	(1)	66643
70	Column	(1)	66557
71	Piston	(1)	92376
72	Packing	(2)	90506
■■	Repair kit for Valve E512LM		116722
☆	Apply PTFE Tape to threads.		
◇	Apply Anaerobic Pipe Thread Sealant to threads.		

**BASIC SINGLE POST RAM/LIFT ASM.**

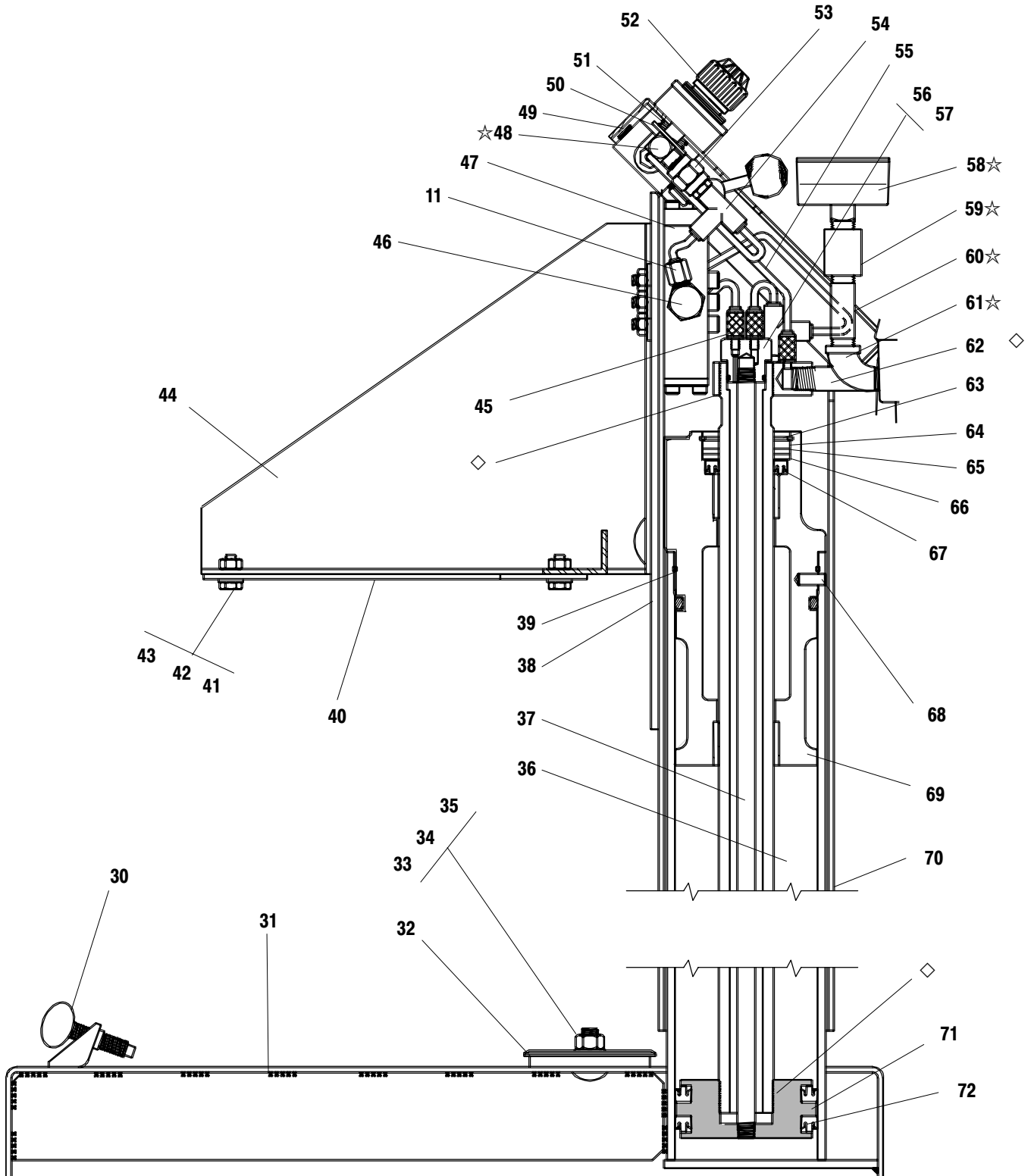

**FIGURE 5**

**DIMENSIONAL DATA**

**91396 MOUNTING PLATE**

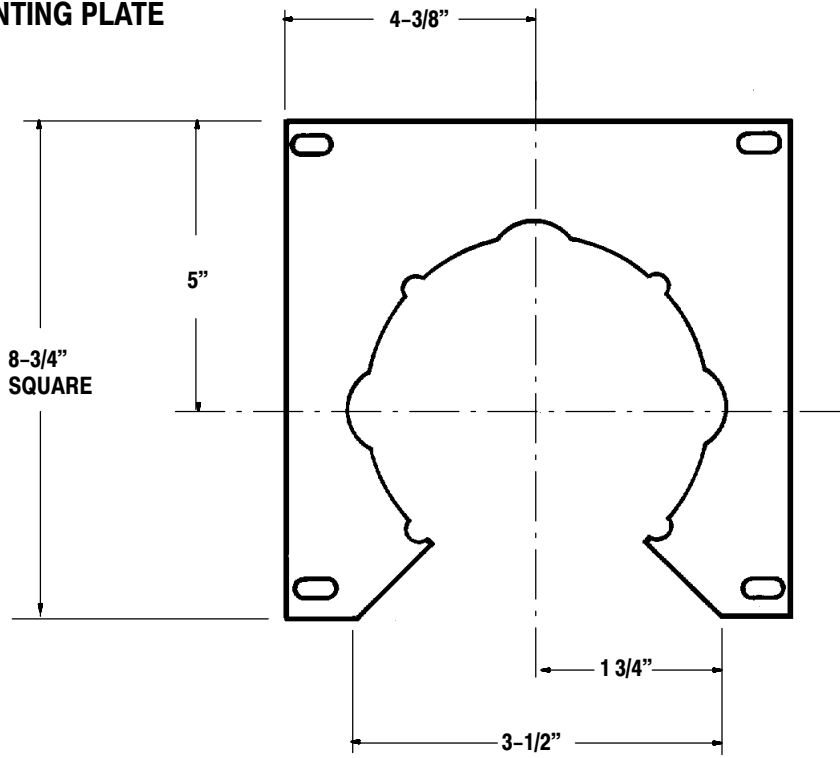

Material-11 Gauge Steel

**FIGURE 6**

**66713 PORTABILITY KIT**

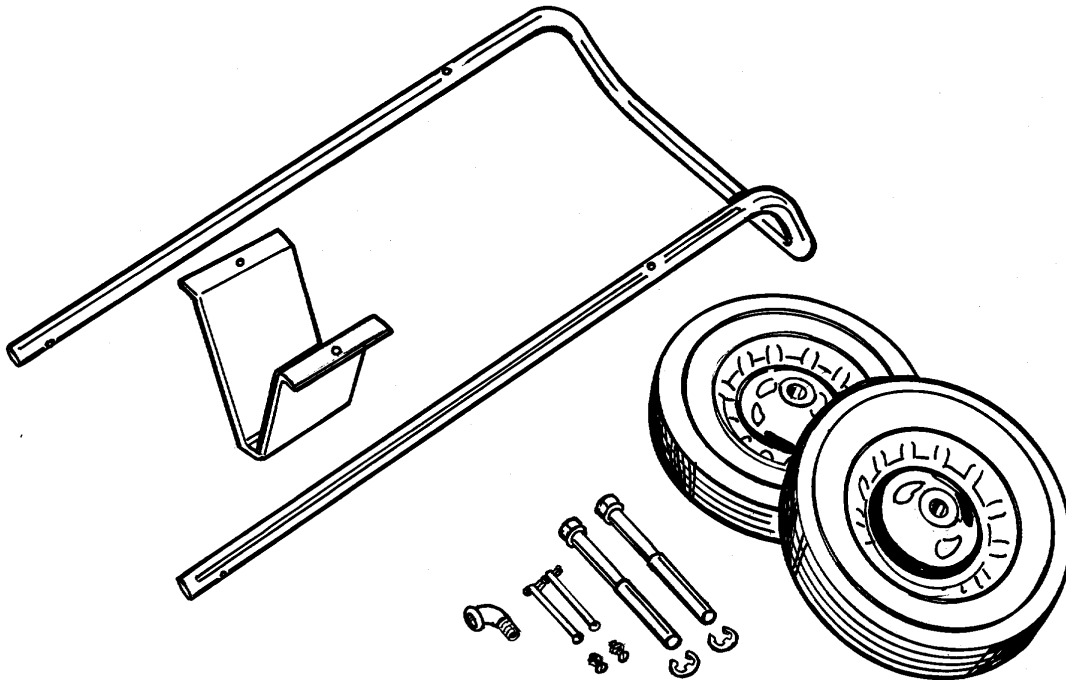

**FIGURE 7**