

PROFESSIONAL SERIES
BUILT-IN HOODS/VENTILATORS WARRANTY

ONE YEAR FULL WARRANTY

Built-in hoods/ventilators, all of their component parts and accessories, except as detailed below*, are warranted to be free from defective materials or workmanship in normal household use for a period of twelve (12) months from the date of purchase. **NOTE:** Viking Range ventilator kits are designed specifically for use with Viking Range hoods. Use of any non-Viking Range ventilator kits **VOIDS** the hood warranty. Viking Range Corporation, warrantor, agrees to repair or replace, at its option, any part which fails or is found to be defective during the warranty period.

*Glass (including light bulbs), painted, and decorative items are warranted to be free from defective materials or workmanship for a period of ninety (90) days from the date of original retail purchase. **ANY DEFECTS MUST BE REPORTED TO THE SELLING DEALER WITHIN NINETY (90) DAYS FROM DATE OF ORIGINAL RETAIL PURCHASE.**

Viking Range Corporation uses the most up-to-date processes and best materials available to produce all color finishes. However, slight color variation may be noticed because of the inherent differences in painted parts and porcelain parts as well as differences in kitchen lighting, product locations, and other factors.

FIVE YEAR LIMITED WARRANTY

Any hood blower motor which fails due to defective materials or workmanship in normal household use during the second year through the fifth year from the date of original retail purchase will be repaired or replaced, free of charge for the part itself, with the owner paying all other costs, including labor.

LIFETIME LIMITED WARRANTY (Outdoor Models Only)

Any stainless steel part which rusts through due to defective materials or workmanship in normal use during the second year through the useful lifetime of the unit from date of original retail purchase will be repaired or replaced free of charge for the part itself, with the owner paying all other costs including labor.

This warranty extends to the original purchaser of the product warranted hereunder and to each transferee owner of the product during the term of warranty.

This warranty shall apply to products purchased and located in the United States and Canada. Products must be purchased in the country where service is requested. Warranty labor shall be performed by an authorized Viking Range Corporation service agency or representative. Warranty shall not apply to damage resulting from abuse, accident, natural disaster, loss of electrical power to the product by anyone other than an authorized Viking Range Corporation service agency or representative. This warranty does not apply to commercial usage. Warrantor is not responsible for consequential or incidental damage whether arising out of breach of warranty, breach of contract, or otherwise. Some jurisdictions do not allow the exclusion or limitation of incidental or consequential damages, so the above limitation or exclusion may not apply to you.

Owner shall be responsible for proper installation, providing normal care and maintenance, providing proof of purchase upon request, and making the appliance reasonably accessible for service. If the product or one of its component parts contains a defect or malfunction during the warranty period, after a reasonable number of attempts by the warrantor to remedy the defects or malfunctions, the owner is entitled to either a refund or replacement of the product or its component part or parts. Replacement of a component part includes its free installation. Warrantor's liability on any claim of any kind, with respect to the goods or services covered hereunder, shall in no case exceed the price of the goods or service or part thereof which gives rise to the claim.

WARRANTY SERVICE: Under the terms of this warranty, service must be performed by a factory authorized Viking Range Corporation service agent or representative. Service will be provided during normal business hours, and labor performed at overtime or premium rates shall not be covered by this warranty. To obtain warranty service, contact the dealer from whom the product was purchased, an authorized Viking Range Corporation service agency, or Viking Range Corporation. Provide model and service number and date of original purchase. For the name of your nearest authorized Viking Range Corporation service agency, call the dealer from whom the product was purchased or Viking Range Corporation. **IMPORTANT:** Retain proof of original purchase to establish warranty period.

The return of the Owner Registration Card is not a condition of warranty coverage. You, however, should return the Owner Registration Card so that Viking Range Corporation can contact you should any question of safety arise which could affect you.

Any implied warranties of merchantability and fitness applicable to the above described hood or ventilator motors are limited in duration to the period of coverage of the applicable express written limited warranties set forth above. Some jurisdictions do not allow limitations on how long an implied warranty lasts, so the above limitation may not apply to you. This warranty gives you specific legal rights, and you may also have other rights which may vary from jurisdiction to jurisdiction.

VIKING RANGE CORPORATION
111 Front Street • Greenwood, Mississippi (MS) 38930 USA • (662) 455-1200

Specifications subject to change without notice.

For more product information, call 1-888-VIKING1 (845-4641), or visit the Viking web site at
F1570F <http://www.vikingrange.com> (M1203VR)

Viking Range Corporation
use and care manual

built-in hoods
(indoor and outdoor models)

Congratulations. . .

Your purchase of this product attests to the importance you place upon the quality and performance of the major appliances you use. With minimal care, as outlined in this guide, this product is designed to provide you with years of dependable service. Please take the few minutes necessary to learn the proper and efficient use and care of this quality product.

We appreciate your choosing a Viking Range Corporation product, and hope that you will again select our products for your other major appliance needs.

- READ AND SAVE THESE INSTRUCTIONS -

Table of Contents

Important Safety Instructions	2
Before Using Your Hood	3
Operation of Your Hood	3
Cleaning and Maintenance	4
Replacing Light Bulbs	6
Service Information	7
Warranty	Rear Cover

Important Safety Instructions

WARNING - TO REDUCE THE RISK OF FIRE, ELECTRIC SHOCK, OR INJURY TO PERSONS, OBSERVE THE FOLLOWING:

1. Use this unit only in the manner intended by the manufacturer. If you have any questions, contact the manufacturer.
2. Before servicing or cleaning unit, switch power off at service panel and lock service panel to prevent power from being switched on accidentally. When the service disconnecting means cannot be locked, securely fasten a prominent warning device, such as a tag, to the service panel.

WARNING - TO REDUCE THE RISK OF A RANGETOP GREASE FIRE:

1. Never leave surface units unattended at high settings. Boilovers cause smoking and greasy spillovers that may ignite. Heat oils slowly on low or medium settings.
2. Always turn hood ON when cooking at high heat or when cooking flaming foods.
3. Clean ventilating fans frequently. Grease should not be allowed to accumulate on fan or filters.
4. Use proper pan size. Always use cookware appropriate for the size of the cooking area.

WARNING - TO REDUCE THE RISK OF INJURY TO PERSONS IN THE EVENT OF A RANGETOP GREASE FIRE, OBSERVE THE FOLLOWING:

(based on "Kitchen Firesafety Tips" published by NFPA)

1. SMOTHER FLAMES with a close-fitted lid, cookie sheet, or metal tray, then turn off the burner. BE CAREFUL TO PREVENT BURNS. If the flames do not go out immediately, EVACUATE AND CALL THE FIRE DEPARTMENT.
2. NEVER PICK UP A FLAMING PAN. You may be burned.
3. DO NOT USE WATER, including wet dishcloths or towels - a violent steam explosion will result.
4. Use an extinguisher ONLY if:
 - You know you have a Class ABC extinguisher, and you already know how to operate it.
 - The fire is small and contained in the area where it started.
 - The fire department is being called.
 - You can fight the fire with your back to an exit.

IMPORTANT SERVICE INSTRUCTIONS

-CAUTION-

FOR GENERAL VENTILATING USE ONLY. DO NOT USE TO EXHAUST HAZARDOUS OR EXPLOSIVE MATERIALS AND VAPORS

Before Using Your Hood

Although the hood is cleaned upon completion of the manufacturing process, you will probably need to clean your hood again after installation. Wipe the surface of the hood with a good household cleaner applied with a soft cloth, or stainless steel polish, depending upon the finish of your hood. This will leave a protective finish on the hood.

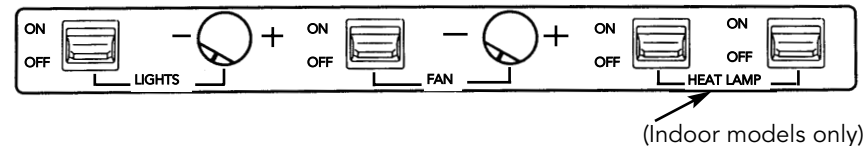

Operation of Your Hood

Always turn your hood on before you begin cooking to establish an air flow in the kitchen. Let the blower run for a few minutes to clear the air after you turn your cooking appliance off. This will help keep the air in the kitchen cleaner.

Each hood has one blower motor which is operated using two (2) controls. Use the on/off control switch to start and stop the blower. When turned on, the blower will operate at the previous setting of the speed control. Turn the speed control knob counterclockwise to decrease the blower speed and clockwise to increase the speed. The type of cooking you are doing will dictate the speed of the blower you will want to use.

Located to the left of the fan switches is the halogen light switch. This controls the 50 watt halogen lights located in the front of the hood. The halogen lights also have a switch which can be rotated in order to dim or brighten the lights. Turn the dimmer control knob clockwise to brighten the lights and counterclockwise to dim.

Each 18" H. indoor hood will be equipped with one or two heat lamp outlets. The switches to operate the heat lamps will be located on the right end of the control panel. The 250 watt infrared bulbs are not included and should be purchased locally. **CAUTION: Do not place flammable material on warming shelves when using heat lamps.**

Heat Sensor Thermostat

Your hood is equipped with a heat sensor thermostat. The thermostat will turn on or speed up the blower if it senses excessive heat above the cooking surface. If the blower is OFF - it turns the blower ON to HIGH speed. If the blower is ON at a lower speed setting - it turns the blower up to HIGH speed. When the temperature level drops to normal, the blower will return to its original setting. **CAUTION: If the power to the hood is not disconnected during cleaning, the heat sensor thermostat can cause the blower to turn ON.**

CAUTION
UNPLUG POWER CORDS FROM CONTROL PANEL
BEFORE CLEANING OR SERVICING HOOD.

Cleaning and Maintenance

Any piece of equipment works better and lasts longer when maintained properly and kept clean. Ventilation equipment is no exception. Your hood must be kept clean and maintained properly.

Cleaning the Baffle Filters

As air passes through a baffle filter, grease particles collect on the stainless steel "U" shaped baffle channels and drip down into the bottom of the filter. Baffle filters are extremely efficient when compared to mesh filters. The power of the hood is increased as more air passes through a baffle filter than with usually dirty mesh filters. The capture of grease is also superior as baffle filters are almost universally required in commercial installations. The baffle filters should be examined periodically to assure that all surfaces and parts are clean. The filters can be washed in a dishwasher or in a sink with hot, soapy water. Simple periodic cleaning will insure maximum filter effectiveness.

- Do not use caustic detergent to clean the filters. A caustic cleaner may damage the finish.
- Do not take the baffle filters apart to clean them. It is not necessary and will void the filter warranty.

When cleaning filters in 18" H. hoods, always remove the grease trough and clean by placing in sink with hot soapy water.

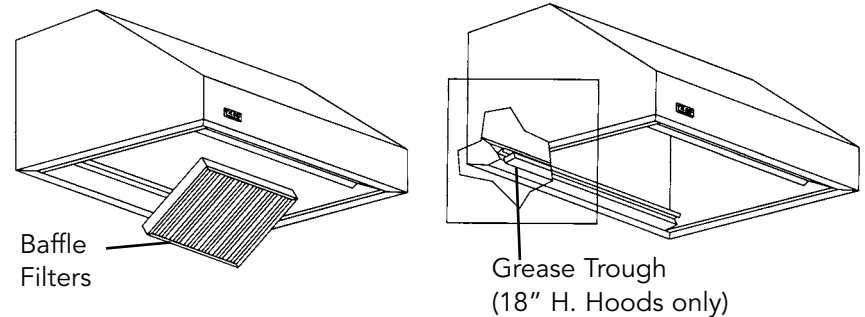

Charcoal Filter Maintenance (Recirculating Hoods Only)

Replace the charcoal filters every 6 months to 1 year depending on the amount and type of cooking.

To replace, remove the baffle/charcoal filter assembly and slide the charcoal filter out of the channel and replace with new one. Do not put the charcoal filters in the dishwasher or oven.

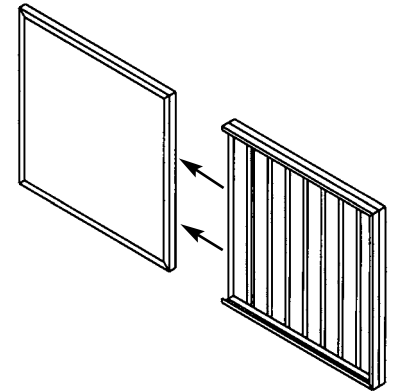

Replacement filters are available through your local Viking Range dealer or you can call the Viking Online Store at 1-877-834-8222.

Replacement filters can also be ordered online at www.vikingrange.com

Cleaning the Hood Canopy

Finishes in enamel or stainless steel are highly resistant to damage or discoloration due to grease, steam, and heat provided that reasonable care is given to the equipment. The following suggestions will help you keep your hood looking new. Do not allow an excessive accumulation of grease. For best results, you should wipe your hood clean with a cloth dipped in warm, soapy water. **DO NOT USE ABRASIVE CLEANSERS, STEEL WOOL PADS, or ABRASIVE CLOTHS.** DO NOT use cleaners that contain chlorides, the chlorides in the cleaner could damage the stainless steel finish.

If necessary to scrape stainless steel to remove encrusted materials, soak the area with hot towels to loosen the material, then use a wooden or nylon spatula or scraper. **Do not use** a metal knife, spatula, or any other metal tool to scrape stainless steel. Every three months give your hood a thorough cleaning. On painted surfaces, use a new coat of wax. A good wax cleaner, available at either a grocery or hardware store will do both jobs at once. On stainless steel surfaces, use a good stainless steel cleaner and polish.

Renewing the Enamel Finish

If discoloration occurs, you should thoroughly polish the finish on your hood to renew its gloss and luster and to remove any grease residue which may have a yellowing effect. Use any good enamel polish, refrigerator polish, or automotive polish. **CAUTION: Do not use a porcelain cleaner or rough abrasive cleaner.**

Renewing the Stainless Steel Finish

Regular cleaning is the best way to assure that your stainless steel finish stays bright and unscratched. Use lemon oil or stainless steel polish to coat and protect stainless steel.

Brass Parts

Caution: All brass special ordered parts are coated with an epoxy coating. **Do not use brass cleaners or abrasive cleansers on the brass option parts.** All brass body parts should be wiped regularly with hot soapy water. When hot soapy water will not do the job, use every day household cleaners that are not abrasive.

Cleaning Ductless Venting Chamber

1. Remove the middle vent by gently raising up and pulling out.
2. Use the same cleaning directions as stated in "Cleaning the Hood Canopy".
3. After cleaning, replace the middle vent.

Replacing Light Bulbs

Halogen Lights

Use an oven mitt during bulb removal to protect your hand in case the bulb breaks.

- 1) Unscrew halogen bulb.
- 2) Replace the bulb with a 120 volt, 50-watt halogen bulb.

Infrared Heat Lamp

Use an oven mitt during bulb removal to protect your hand in case the bulb breaks.

- 1) Unscrew infrared bulb from heat lamp socket.
- 2) Replace the bulb with an R40, 120 volt, 250-watt infrared bulb.

Service Information

If your hood should fail to operate check to see if the the circuit breaker is open, or if a fuse is blown?

If service is required:

1. Call your dealer or authorized service agency. The name of the authorized service agency can be obtained from the dealer or distributor in your area.
2. Have the following information readily available:
 - a. Model number
 - b. Serial number
 - c. Date purchased
 - d. Name of dealer from whom purchased
3. Clearly describe the problem that you are having.

If you are unable to obtain the name of an authorized service agency, or if you continue to have service problems, contact Viking Range Corporation at (601) 451-4133 or write to:

VIKING RANGE CORPORATION PREFERRED SERVICE

111 Front Street
Greenwood, Mississippi (MS) 38930 USA

Record the information indicated below. You will need it if service is ever required. The model and serial number for your hood is located behind the baffle filter on the left side panel in the lower right corner.

Model Number _____ Serial Number _____

Date of Purchase _____ Date Installed _____

Dealer's Name _____

Address _____

If service requires installation of parts, use only authorized parts to ensure protection under the warranty.

**THIS MANUAL SHOULD REMAIN WITH THE HOOD FOR
FUTURE REFERENCE**