



# MODEL G0625 BENCHTOP LATHE EXTENSION TABLE INSTRUCTION SHEET

## Introduction

The Model G0625 Extension Table extends the bed length of the Model G0624 10" Benchtop Lathe to 38" between centers.

## Inventory: (Figure 1)

- A. Extension Bed ..... 1
- B. Rubber Feet ..... 2
- C. Cap Screws M8-1.25 x 35..... 4
- D. Flat Washers 8mm ..... 4
- E. Hex Wrench 6mm ..... 1

## Installation:

1. Install the feet into the bottom of the extension table.
2. Align the mounting holes in the extension table and the tailstock end of the Model G0624 bed.
3. Thread four cap screws with flat washers through the extension table and lathe, and finger tighten.
4. Center the tailstock over the extension table and lathe as shown in **Figure 2**.
5. Tighten the cap screws with the hex wrench, to bring the bed extension and lathe surfaces even with the bottom of the tailstock.
6. Slide the tailstock over the bed.

—If the tailstock catches on the area where the lathe and extension table meet, loosen the fasteners and repeat **Steps 3-5** until the tailstock slides smoothly.

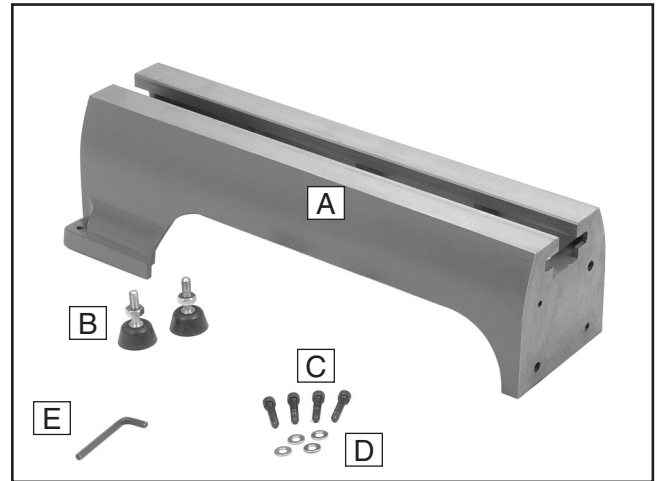

**Figure 1.** Model G0625 inventory.

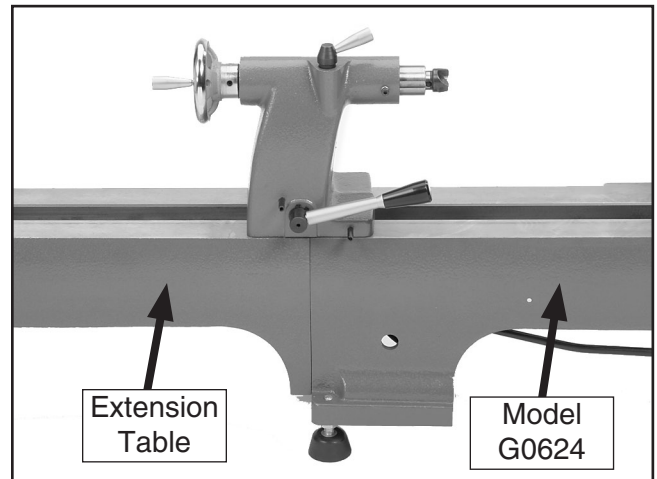

**Figure 2.** Tailstock centered over extension table and lathe.

7. Place a straightedge over the extension table and lathe beds and check to see if both are parallel and aligned.

COPYRIGHT © NOVEMBER, 2006 BY GRIZZLY INDUSTRIAL, INC.

**WARNING: NO PORTION OF THIS MANUAL MAY BE REPRODUCED IN ANY SHAPE OR FORM WITHOUT THE WRITTEN APPROVAL OF GRIZZLY INDUSTRIAL, INC.**

#BL8694 PRINTED IN CHINA

—If the extension table tilts down, use a strip of masking tape along the bottom edge of the lathe to shim the table up (**Figure 3**).

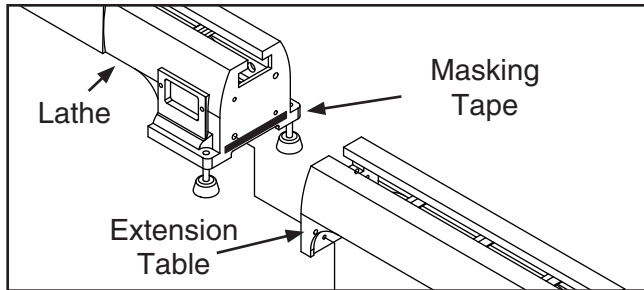

**Figure 3.** Shimming extension table up.

—If the extension table tilts up, use a strip of masking tape along the top edge of the lathe to shim the table down (**Figure 4**).

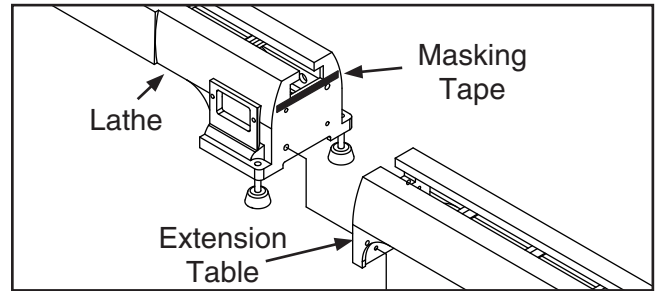

**Figure 4.** Shimming table down.

—If the extension table is skewed to the left or right, use a vertical strip of masking tape along the corresponding edge of the lathe to make the extension table parallel with the lathe (**Figure 5**).

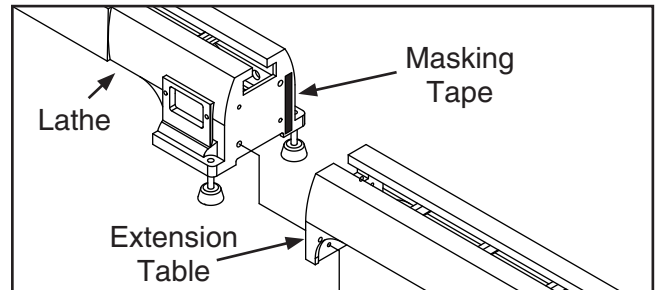
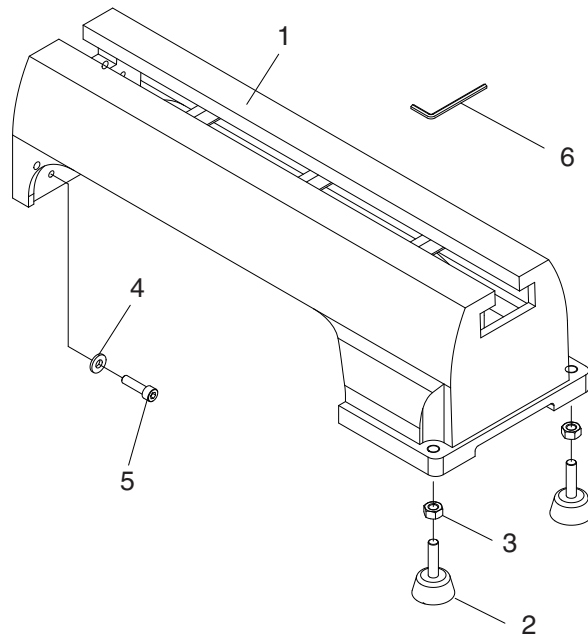

**Figure 5.** Shimming table to the left.

Refer to the Model G0624 manual for instructions on operating the lathe.

*If you need help with your new extension table, call our Tech Support at: (570) 546-9663.*

## G0625 Parts Breakdown and List



REF	PART #	DESCRIPTION
1	P0625001	BED EXTENSION
2	P0625002	RUBBER FOOT
3	PN08	HEX NUT 3/8-16
4	PW01M	FLAT WASHER 8MM
5	PSB40M	CAP SCREW M8-1.25 X 35
6	PAW06M	HEX WRENCH 6MM