

Mobrey

MSM400 Intelligent Suspended Solids Monitor

Software Version 1.1

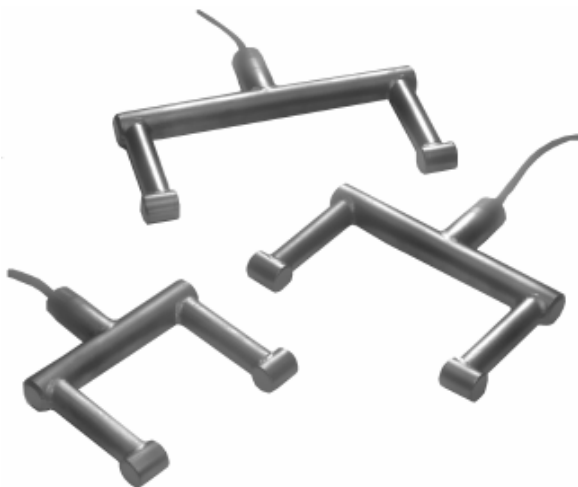

CONTENTS

	Page
1. PRODUCT INTRODUCTION	5
1.1 The MSM400 slurry monitoring system	5
1.2 Description	5
2. SENSOR TYPES	
2.1 Safety Precautions	7
2.2 Hazardous Area systems	7
2.3 Quick Start guide	8
3. CONTROL UNITS	9
3.1 MSM400 Displays and Keypad	9
3.2 Specifications	10
4. INSTALLATION	
4.1 Preliminary Checks	11
4.2 Pipe Section Installation	11
4.3 Suspended Sensor Installation	11
4.4 Sensor Cabling	12
4.5 Control Unit	12
4.6 Electrical Connections	13
5. PROGRAMMING	
5.1 Programme Structure	16
5.2 Navigation in the Menu System	19
5.3 Diagnostic Parameters	18
5.4 Ex-Factory System Features	18
6. CALIBRATION	
6.1 Zero Setting	18
6.2 Re checking Zero	19
6.3 Auto cal zero setting procedures	19
6.4 Auto cal span setting procedure	20
6.5 Auto cal lab values	21
6.6 Maximum % solids	22
6.7 Calibration - Alternative method	22
6.8 Zero setting procedure	22
6.9 Span Calibration Methods	22
6.10 Method 1-Slurry Type	22
6.11 Method 2-Sample Calibration	22
6.12 Method 3-Attenuation Value	23
7.0 PROGRAMMING THE MSM400 FUNCTIONS	24
7.1 Outputs	27
7.2 Current output	27
7.3 Relay Operation	27
7.4 Alarm	28
7.5 Display	28
7.6 Back Light	29
7.7 Engineering	29
7.8 System	29
8. HART SMART COMMUNICATIONS	30
9. MAINTENANCE / INSPECTION	30
APPENDICES	
A1. Full Listing of Menu Structure	31-32
A2. Full List of Programme Parameter Functions	33-37
A3. HART and PSION Operating Instructions	38-40
D. Handheld Communicator - Assembly Instructions	41-59

Footnote :-

In this manual the following terms are used which refer to trademarks from other manufacturers:

HART: is the protocol adopted for the MSM400 SMART Communications.

HART is a registered trademark of the HART Communications Foundation and is a mnemonic For Highway Addressable Remote Transducer.

PSION: is the trade mark of PSION plc who manufacture the PSION ORGANISER Hand held computer.

The MOBREY SMART program is stored in a DATAPAK which is also a trademark of PSION plc, and is an accessory for the Model LZ Organiser

Safety Precautions

The following safety precautions should be observed before using this product or working on the attached cables. This MSM400 product is intended for use by qualified personnel who recognize shock hazards and are familiar with the safety precautions required to avoid possible injury. Read the operating information carefully before using the product.

The types of product users are:

Responsible body: This is the individual or group responsible for the use and maintenance of equipment, and for ensuring that operators are adequately trained.

Operators use the product for its intended function. They do not require access to the electrical connections within the control box, and would normally only operate the external keypad and monitor the display.

Maintenance personnel perform routine procedures on the product to keep it operating, for example, checking the line voltage or checking electrical connections, replacing mains fuses etc.

Service personnel are trained to work on live circuits, and perform safe installations and repairs of products. Only properly trained service personnel may perform installation and service procedures. However, the only serviceable part in MSM400 is the mains cartridge fuse.

Users of this product must be protected from electric shock at all times. Product users must be trained to protect themselves from the risk of electric shock.

Before operating the instrument, make sure the mains supply is connected to a properly grounded power supply. Periodically inspect the connecting cables for possible wear, cracks, or breaks. Check lid and glands are tight, also check unit for damage and if damaged do not use.

The fuse may only be replaced with same type and rating for continued protection against fire hazard.

To clean the instrument, use a damp cloth or mild, water based cleaner. Clean the exterior of the instrument only. Do not allow liquids to enter or spill on the instrument.

WARNING - If this equipment is used in a manner not specified by Mobrey Measurement, the protection provided may be impaired. The MSM400 is regarded as permanently installed equipment and as such a double pole supply isolating switch or circuit breaker must be included in the installation. This should be in close proximity to and not be obstructed by the equipment. It should be marked as its disconnecting device.

A protective earth must be used for all applications.

The installation of the MSM400 and its associated power cables must be such that tank overflow, local flooding or pump failure do not cause these to be submerged or subject to flows of water. Sensors and sensor cabling can be submerged without hazard to equipment operators when correctly connected as described in this manual.

CHECK THAT THE POWER SUPPLY IS SUITABLE BEFORE SWITCHING POWER ON.

Internal adjustments can select mains 115 Volts AC power, which makes the equipment unsuitable for 230V AC supplies. Check this Voltage selection switch compared to the available power supply.

Explanation of symbols:



The Protective earth terminal must be connected to an external Protective earthing system.



Refer to manual.

Hazardous area systems :-

Where the MSM400 is connected to sensors located in an explosive atmosphere additional instructions apply. Refer to Safety Instructions IP258/SI

QUICK START

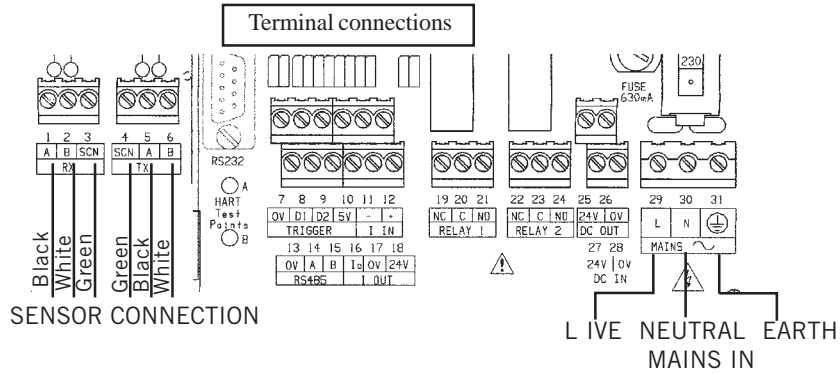

- 1) Connect the mains supply to the terminal connections L, N and E as shown above.
- 2) Connect the sensor to the terminals as shown above.
- 3) With power on, press a button on the key pad as shown below. This will access the main menu.



- 4) Navigation around the menu system is achieved by using the up and down arrow keys to highlight an option and the ENT key to access the various levels. Pressing ESC returns the user to the previous level. Highlight toggle run and press ENT. PRESS ENT AGAIN to open the toggle run padlock. Press ESC to return to main menu. Parameters may now be altered.
- 5) To calibrate the unit, highlight CALIBRATION and press ENT.
- 6) Now highlight AUTOCAL and press ENT.



- 7) Highlight SETZERO and press ENT

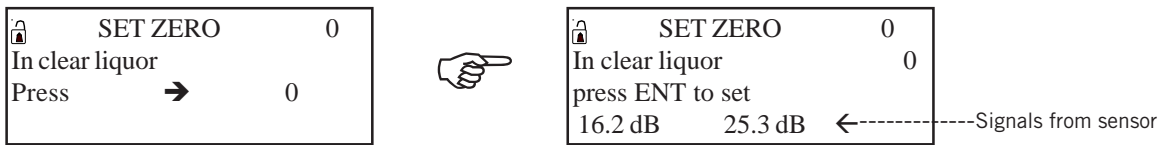

- 8) Follow the instruction then wait a few seconds.
- 9) When ENT is pressed the zero is set. Press ESC four times to return to normal display.
- 10) Follow the same procedure to set the span. i.e. Highlight SETSPAN in the AUTOCAL menu and press ENT. Up to 3 SPAN values can be taken. Press down arrow to access next span.
- 11) When setting span, sludge samples should be taken for analysis. The results of the samples are the input to the control unit for reference in THE LABVALUES menu.

INPUTTING A VALUE

- 1) Access the parameter as shown below :

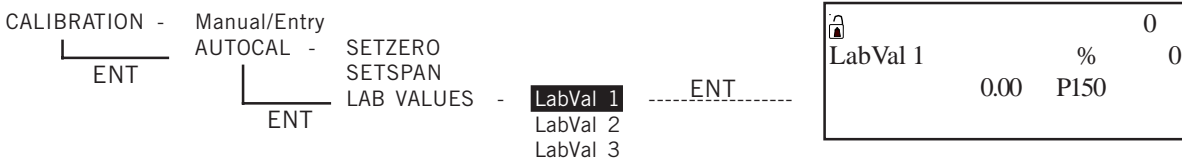

- 2) To input a value press the right arrow to highlight the correct digit to be altered. The value of the digit is then incremented or decremented by using the up or down arrows. To save a value press ENT. 'ESC to return to menu'
- 3) Now input your expected max % solids required. Located in - Calibration - AUTOCAL - Max %. (See section 6 for details)
- 4) All other parameters are setup in a simpler way and can be located by looking at the full menu structure in Appendix 1 of this manual.
- 5) For outputs to be made active Toggle run padlock must be closed.
Note: Press and hold ESC to return to the main menu form any where in the menu structure. Press ESC once more to return to normal display. Once a parameter is reached (indicated by P*** or D*** on the display) all other parameters can be reached by simply scrolling using the up or down arrows.

1.0 PRODUCT INTRODUCTION

1.1 THE MSM400 SLURRY MONITORING SYSTEM

The MSM400 is an advanced Microprocessor based, HART compatible, versatile slurry measurement system, with a wide range of built-in display, control and alarm function options. The Menu driven programming is simple to use, and allows complete configuration of the unit from the external membrane keypad. Sensor and electrical connections are in a separated terminal housing.

This manual is for Software Version 1.1

1.2 PRODUCT DESCRIPTION

The Mobrey MSM400 is a microprocessor based electronic control unit. It operates with sensors mounted in a pipe section or suspended in a tank. The MSM400 monitors the suspended solids concentration in the liquid between the two sensor faces. The normal application is to monitor this percentage, typically in the range 0.5% to 15%, to provide signals for a plant control system to operate the slurry transport process. Typically this might be to desludge a sewage settlement tank, or in mineral processing to maintain the percent solids of china clay, or similar, moving on to further refiners.

The technique used to measure suspended solids is ultrasonic attenuation. As suspended solids pass between the gap in the sensor faces they scatter the ultrasound. The amount of signal that the sensor receives is inversely proportional to the % of suspended solids.

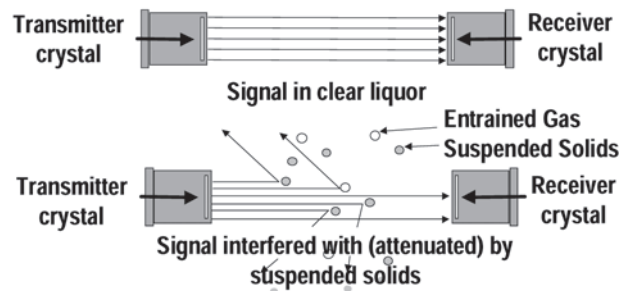

To allow accurate measurement over a wide range of % solids the attenuation is measured at 2 different frequencies.

Control signals :

The MSM400 has a 4-20mA, 2 relays and analogue output, typically 4-20mA, The MSM400 can control a desludge operation using a combination of measured % solids, external trigger and internal timers.

The unit is also HART compatible, to feed in to digital control systems using HART protocol.

A typical application would be with the sensors mounted in a discharge line from a refiner or settlement tank. The relay in the MSM400 would be used to stop the de-sludge cycle when the liquor runs clear, switching at typically about 4-5% suspended solids. The ultrasonic technique has an advantage over some techniques in that it is largely unaffected by fouling of the sensor face.

SLURRY CHARACTERISTICS

The relationship between the measurement of ultrasonic attenuation and the percentage solids of a particular slurry type is dependent on the density of the slurry particles and their average size distribution. This is known from experience for most slurry types, and is expressed as a number, which is the ultrasonic attenuation in decibels (dB), per mm gap between sensor faces, per one percent suspended solids.

The relationship between attenuation and suspended solids is shown graphically in Figure 2. Calibration of the unit involves adjustment of the zero point, by setting up the sensors in clean liquid (supernatant), and then setting the slope of the straight line graph, either according to past data or from site samples.

In the memory of the MSM400 there is information on various slurry types, to enable simple initial set-up. More accurate adjustment can then be made once site samples have been taken.

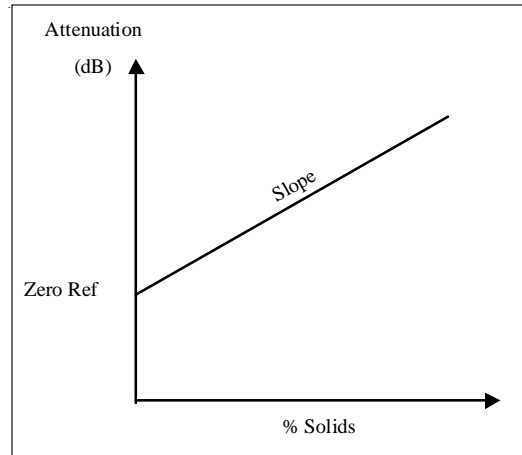

Figure 2 : Ultrasonic Attenuation versus Suspended solids

Calibration:

The Mobrey experience with using ultrasonics for suspended solids monitoring has been developed over 25 years. Calibration systems for the MSM400 use this experience, allowing the plant operator to choose whether to set up the unit based on Mobrey site and slurry experience, or whether to take site samples to fine tune that data to suit the specific site conditions. The MSM400 is versatile enough to allow simple or complex calibrations.

2.0 SENSOR TYPES

2.1 SUSPENDED SENSOR TYPE MSM433

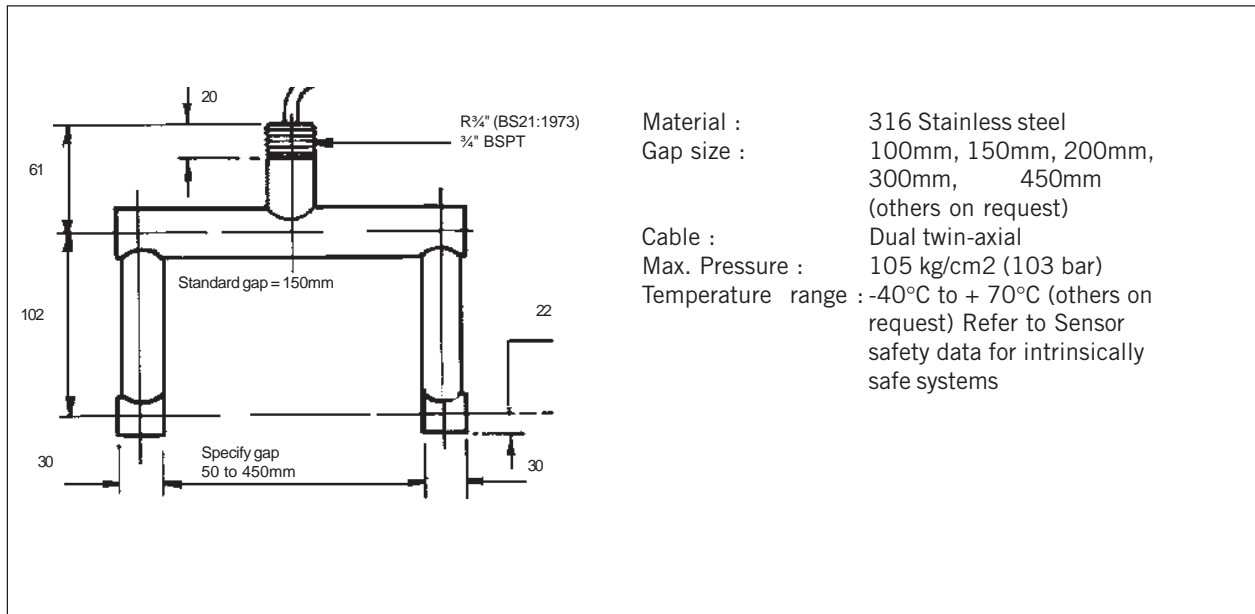

Figure 3 : MSM433 Sensor and Specifications

2.2 MOBREY PIPE SECTION SENSORS

The Mobrey pipe section is used as part of a pipeline transporting the slurry to be monitored. Each pipe section contains two sensors, installed with their faces accurately aligned and flush with the pipe inner wall, to avoid any excessive slurry or grease build up on the faces.

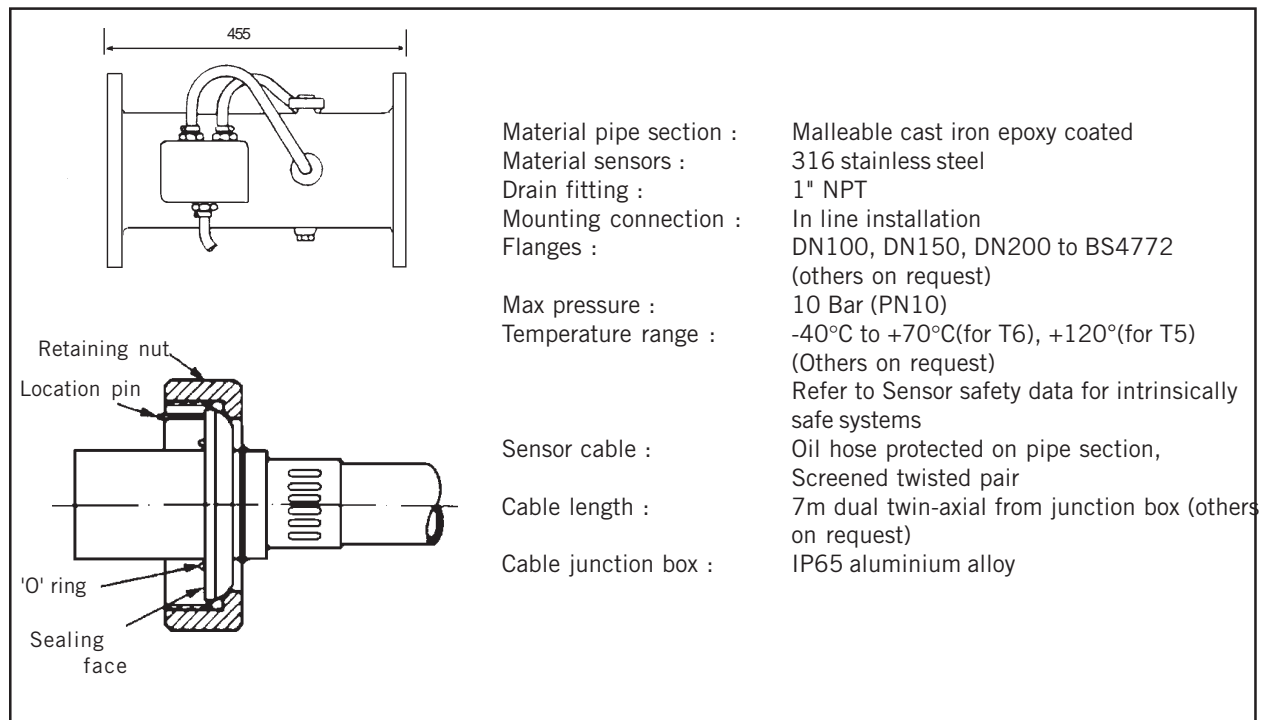
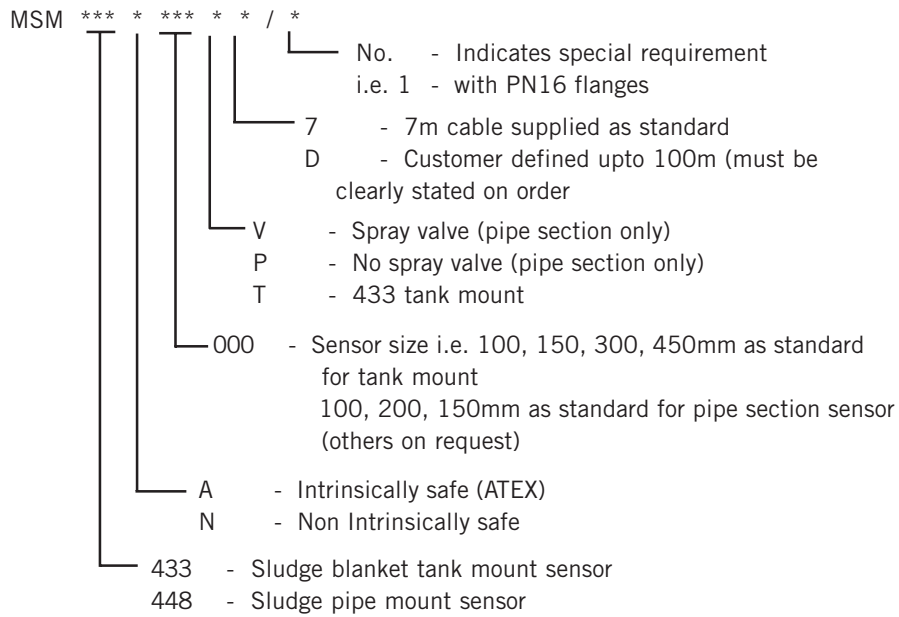

Figure 4 : MSM448 Pipe Section Sensors

2.3 SENSOR TYPE NUMBERING SYSTEM



In intrinsically safe systems, the maximum length of integral cable permitted by the sensor certification is 50m. Additional extension cables are however permitted.

3.0 CONTROL UNIT

3.1 MSM400 DISPLAYS AND KEYPAD

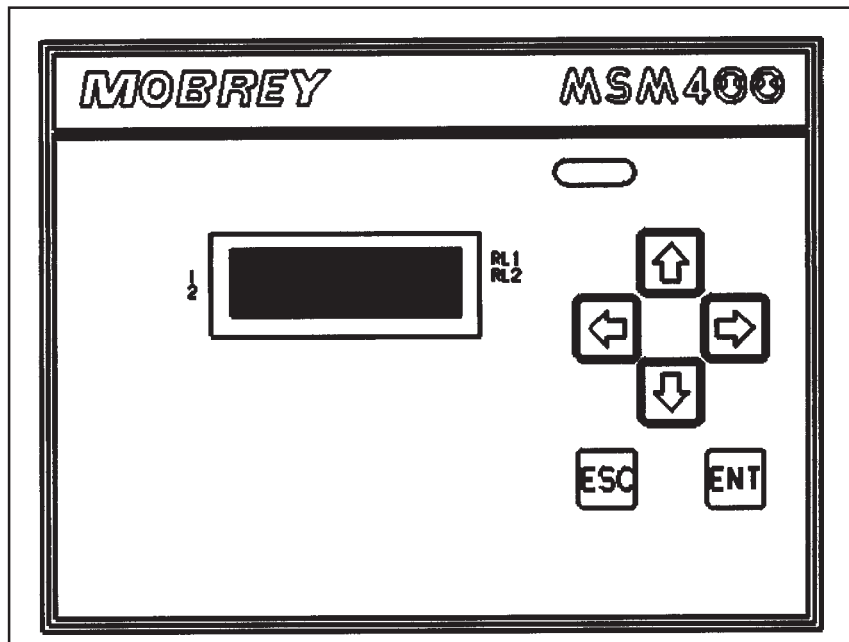

Figure 5 : MSM400 keypad and LCD display

The MSM400 is wall mounted: the lower section of the housing is for cable connections, and the upper part has the 4 line LCD and keypad controls. The whole unit is IP65.

Typically the display will show as in Figure 7, the top line shows whether the programme lock is open together with the time display. The actual value is displayed in the centre. The attenuation figure in decibels is on the bottom line.

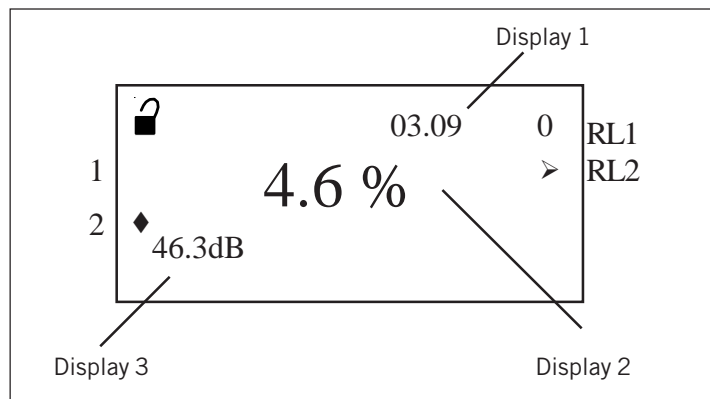

Figure 6 : Typical MSM400 liquid crystal display

Additional flags on the display show the status of the two relay outputs, RL1 and RL2, and of the digital control inputs into the MSM400.

KEYPAD OPERATION :

There are 6 buttons on the MSM400 front panel, the four ARROWS allow navigation around the programming menu and the "ESC" and "ENT" buttons allow movement from one screen to the next. By pressing "ESC" repeatedly, the screen will always return to the normal display as shown in Fig 7. Movement through the menu structure using the arrows is shown by the titles being "highlighted", ie reversed to showing white letters on a black background. The LCD is backlit for operator convenience. (This can be turned off if required).

3.2 SPECIFICATIONS--MSM400

Housing	ABS with polycarbonate lid, IP65
External dimensions	256.5 wide, 236.7 high, 95.0 deep, including wall mounting brackets
Cable Glands	3x 16mm holes and plastic glands supplied 3x 20mm holes and plastic glands supplied
Weight	2 kg
Wall Mounting holes	6 off Diam 5.0mm (See Drawing Section 4.5)
Power supply options	115 V a.c. ($\pm 15\%$) 50 / 60 Hz 230 V a.c. ($\pm 15\%$) 50 / 60 Hz or 24 V d.c. (15 to 30 Volts)
Power consumption	a.c. 10VA d.c. 6W
Fuse (F1)	200 mA (T) 5 x 20mm
Current Output	0-20 or 4-20 mA selectable, maximum load $1K\Omega$ (at 22mA) maximum applied voltage 48v d.c
HART	HART digital communications, Two HART internal test terminals provided.
Relay Outputs	2x SPCO Relays, rated 5 Amps at 250 V a.c. Resistive
DC Power Output	24V DC for external sensors such as Mobrey Electrosensor
Sensor connections	Terminals for Mobrey sensor Tx and Rx cables, each 2 cores and screen
Trigger inputs	Unit accepts two 5V d.c.trigger input signals. 5V d.c. provided - compatible with Mobrey Electrosensor
Terminals	Max. cable size 2.5mm ²
Ambient temperature	-30°C to 55°C
Max Altitude	2000m
Max Humidity	95% RH
Electrical Safety	Conforms to EN61010-1
Installation Category	Cat III 132V a.c. Max., Cat II 264V a.c. Max.
Pollution Degree	2
EMC	Complies with EN61326 (Industrial level)

4 INSTALLATION

4.1 PRELIMINARY CHECKS

The MSM400 system is normally supplied in two packages, one for the MSM400 Control Unit and one for the sensor, whether it is a pipe section or a tank sensor. Take care in handling the pipe section. In particular do not damage the cable or the hose protection for the cable where it enters the sensors. Before installation check that there has been no damage in transit, particularly to the sensor cables. Check that the equipment is as specified, and that the pipe section length and flanges are compatible with plant pipework.

Sensors in intrinsically safe systems may be mounted in potentially explosive areas ("hazardous areas"). Refer to the sensor safety data section 2.4.

The control unit must be mounted in a non-hazardous ("safe") area. Refer to control unit safety data section 3.3.

4.2 PIPE SECTION INSTALLATION

The Mobrey MSM448 pipe section sensor should be same size as surrounding pipe work. It should be installed in a straight section of line, if possible, with the sensors in a horizontal plane. This avoids the sensors being covered with debris at the bottom of the pipe, and being in an air gap at the top of the pipe. Particular attention must be paid to the positioning of the pipe section in relation to pressure reduction or agitation of the slurry to be monitored :

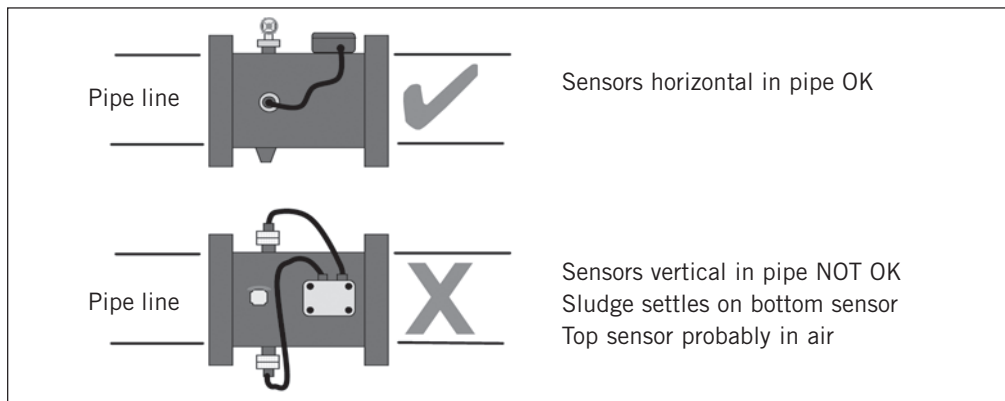

Figure 7 : Pipe sensor orientation

WARNING:

Air or gas that comes out of suspension in a slurry gives a high ultrasonic attenuation, giving a false high solids reading. The installation must maintain the full hydrostatic pressure in the slurry up to the pipe measurement section. Any unnecessary pressure reduction should be avoided. This means avoid free fall of the slurry into a sump, avoid pumps and partly open valves, avoid abrupt changes of pipeline diameter upstream of the sensor pipe section installation point. If possible position the sensors directly at the outlet of the tank, low down, so that the full hydrostatic head is maintained on the monitored liquid. However, it may be necessary to remove the sensors for face cleaning later, so isolation valves are desirable. The Mobrey Sensor pipe is supplied with a flushing spray nozzle, which directs a supply of water at the sensor faces. This is a useful cleaning procedure, avoiding the need to remove the sensors from the pipe. A water supply is required, connected to the purge nozzle on the top of the sensor pipe section.

4.3 SUSPENDED SENSOR INSTALLATION

The Mobrey MSM433 sensor is available with the gap between sensor faces from 100 mm up to 450 mm, for higher sensitivity to light slurries. These sensors are usually mounted directly into the settlement tank, at pre-selected levels above the tank discharge outlet. Mounting can be vertically down on a piece of conduit, or suspended on the sensor cable. Whilst the conduit might be attached to the tank wall, it is normal to have the sensor well away from the wall itself, to avoid any non moving slurry or "dead" settlement areas. It should be possible to lift the sensor out for periodic cleaning and/or rag removal.

4.4 SENSOR CABLES

The ultrasonic drive signals on the sensor cables are normally at 1MHz and 3.3MHz. The cables are a special construction of two separately screened twisted pairs, designed to meet electromagnetic compatibility regulations. The cables can be extended up to 100 metres, but should use the same cable type, available from Mobrey Measurement. (or consult factory for alternative vendors). The certification for intrinsically safe systems requires that cable joins should be in enclosures rated at least IP20 and suitable for the intended environment and that the wiring should withstand a test voltage of 500V rms to earth. The electrical parameters of the cable used must conform to Table 1 in section 2.4.

Twisting the cables on installation should be avoided. Cable runs should be separated from any high voltage or mains cables, to avoid crosstalk or switching transients.

4.5 CONTROL UNIT

The control unit housing is rated IP65. It is suitable for mounting outside, but this should be above any flood level, away from any overflow water path, and away from direct sunlight. Internal sensors turn the LCD backlight off if the temperature is excessive.

The control unit must not be mounted in areas where an explosion hazard exists.

It is not necessary or advisable to remove the lid to the upper part of the box, containing the LCD and keypad. There are no user serviceable parts inside. The control unit must not be modified in any way. The keypad and LCD are linked to the lower electronic pcb by a ribbon cable at the left hand side of the upper housing. Mounting brackets for wall mounting are provided, and these should be attached to the rear of the housing using the self tapping screws (also provided). The brackets are then used to wall mount the MSM400, using the six mounting holes available. Dimensional information is shown below:

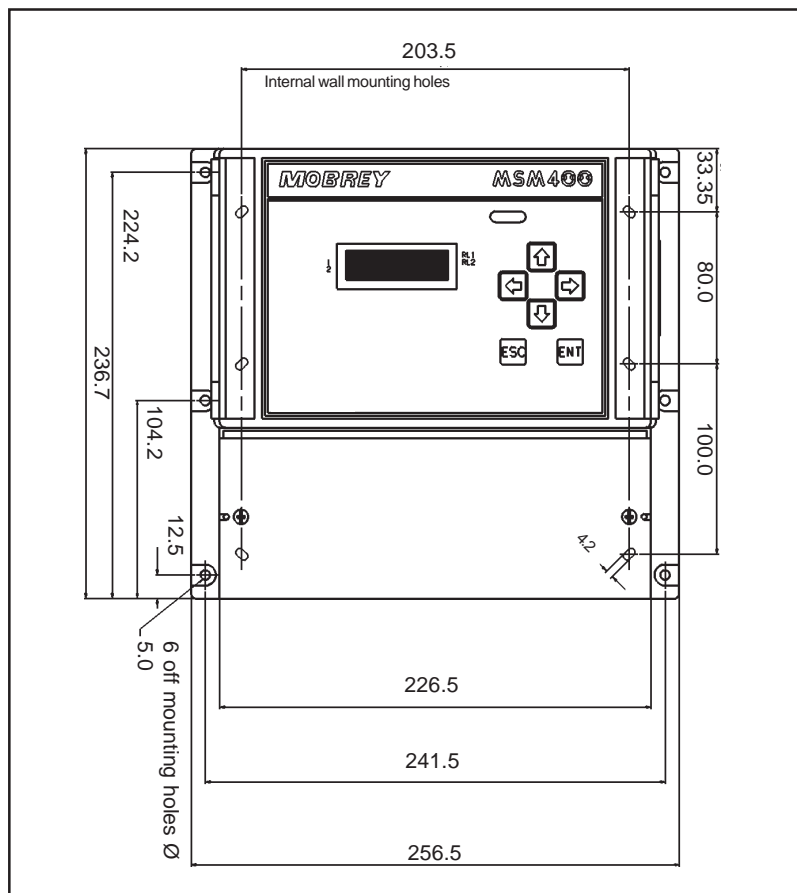

Figure 8 : MSM 400 Control Unit Dimensions

Note that the weight of the MSM400 is 2Kg. To conform with safety requirements the wall should be capable of supporting 4 x this weight, ie. 8Kg. 5mm diameter steel screws should be used.

4.6 ELECTRICAL CONNECTIONS

All field wiring connections are accessible by removing the lower lid, which is secured by two screws. Note that it is the responsibility of the installer to observe all local regulations and approval requirements, and to use cable to suit the environmental requirements of the particular application. Obtain and check any hazardous area work permits required before applying power to the MSM400.

The diagram below shows the layout of external connection terminals: all terminal blocks are suitable for wires 0.5mm² to 2.5mm² (26-12 AWG). Insulation should be stripped back 7mm.

Ensure wiring is suitable for the load current and the insulation is suitable for the voltage, temperature and environment of the installation.

Note that in intrinsically safe systems, apparatus connected to the MSM400 must not be supplied from a voltage greater than 250V rms or 250V DC.

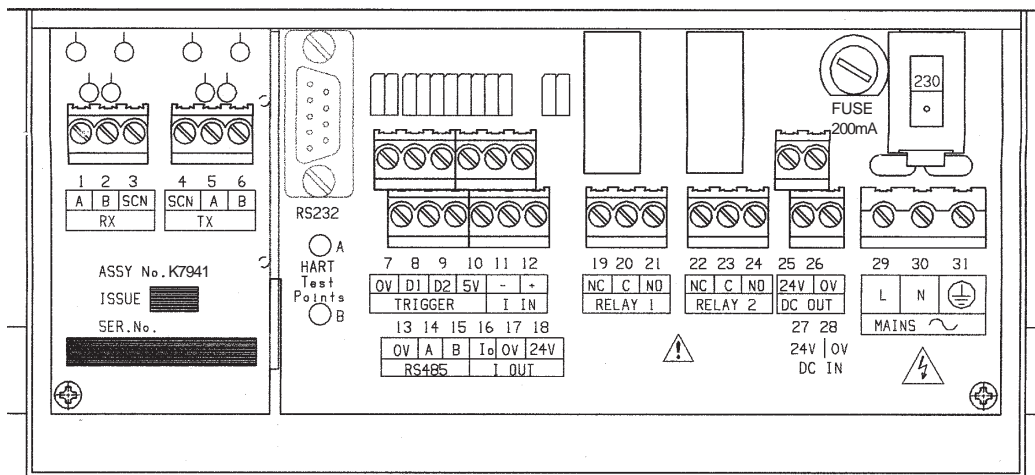

Figure 9: Connection Terminal Layout

Note that not all of the labelled terminals are functional in this version of the MSM400. The functions available are listed below :

CONNECTION DESCRIPTIONS :

Terminal	Label	Function
1	RX A	Sensor Cable
2	RX B	Sensor Cable
3	RX SCN	Screen for 1+2
4	TX SCN	Screen for 5+6
5	TX A	Sensor Cable
6	TX B	Sensor Cable
7	TRIGGER 0V	Ground ref for Trigger inputs
8	TRIGGER D1	Digital input No 1
10	TRIGGER 5V	5 V output
16	I out Io	Current output (4-20mA)
17	I out 0V	Current output zero ref terminal
18	I out 24V	Current output 24 V DC loop power : refer to Fig. 10
19-21	RELAY 1	NC-C-NO Relay output terminals for Relay 1
22-24	RELAY 2	NC-C-NO Relay output terminals for Relay 2
25	DC out 24V	Output of 24 VDC for powering external devices.
26	DC out 0V	Ref for DC output
27	DC in 24V	Positive supply at 24VDC to the MSM400--ie DC power input
28	DC in 0V	Ref terminal for DC supply input
29	Mains L	AC power input 115/230V, Live terminal NB: SELECT 115 or 230V
30	Mains N	AC power input 115/230V, Neural terminal ON SWITCH ABOVE
31	Mains E	Protective Earth (PE) THESE TERMINALS

NOTE 1 The sensors are symmetrical, so either of the two cable pairs can be chosen as "Tx" or "Rx"

SENSOR CONNECTIONS

The sensor connections are on the left side of the terminal enclosure.

Each sensor has two screened twisted wire pairs, either as one dual pair cable, or two separate pairs. One pair is connected to the TX (transmit) group and the other to the RX (receive) group. The sensors are symmetrical so either of the pairs can be chosen as TX or RX. The two cores in each group are connected to A and B, the polarity is not important. Each screen connection, normally coloured green, is connected to the group's SCN terminal. Cable screens must not be earthed at any other point.

The un-screened length of the cores should be as short as possible, to prevent crosstalk, but in any case no longer than 30mm.

RELAYS

The relay NC-C-NO labels represent the relay terminals in the de-energised state.

HART CONNECTIONS AND JUMPER SETTINGS

There are two clearly labelled HART Test Points, labelled A and B. These test points are for connection of a HART Hand Held Communicator, to provide a local interface to the MSM400 if required. Above terminal blocks 7-12 there is a plug selector labelled PL1.

The normal position is with the plug shorting out the left hand pins. In this case, the external 20 mA loop must have at least a 250 ohm impedance to enable HART communications. With the plug in the central position, the MSM400 itself provides this load in the 20 mA loop. The right hand position enables HART communication when there is no external loop connected by connecting a 270 ohm resistor across the current output. (See Appendix D).

NOTE:

The 20 mA output will not function correctly when the link is in this right hand position, so replace it in position 1 or 2 after use!

CURRENT OUTPUT

The current output may be connected in loop-powered mode or internally powered mode. See connections in Fig 10 below.

In Loop-powered mode an external power source is required. A minimum of 2.5v is required across terminals 16 and 17 for correct operation. The external voltage should not be more than 30v.

Note that the current output must not be routed through hazardous areas unless protected by an additional I.S. barrier.

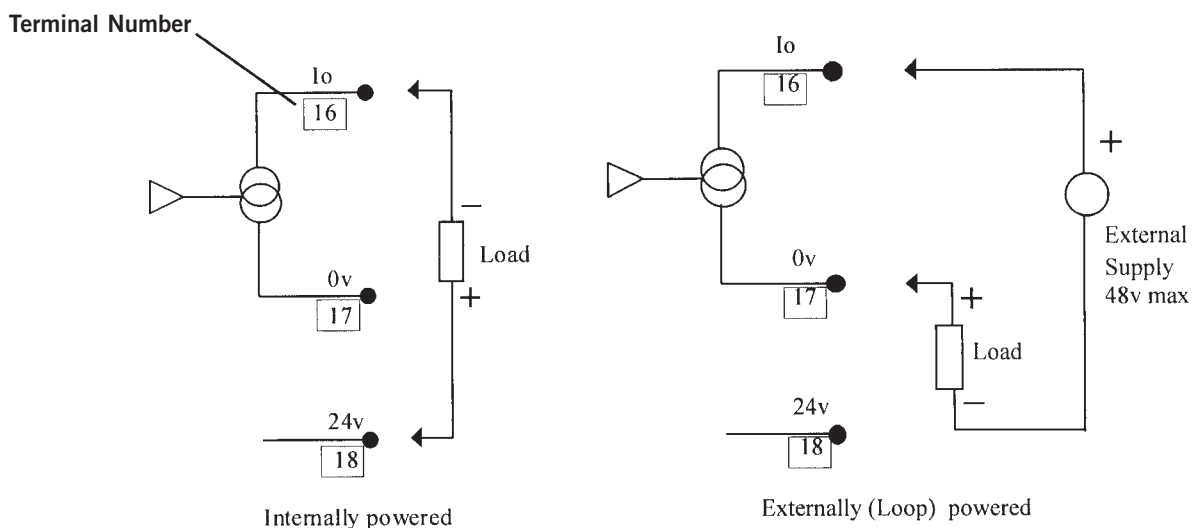
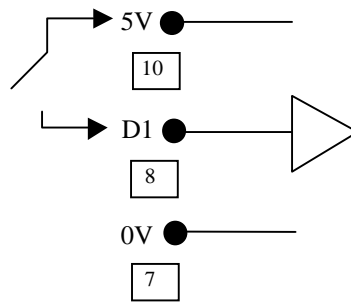

Figure 10 : Alternative current output configurations

TRIGGER INPUTS

There is trigger input D1. This can be used to control desludge and other functions see programming section. The digital trigger input is connected as shown below:



A voltage greater than 2V on Terminal 8 (D1) causes trigger input 1 to be active. This can be achieved by connecting to terminal 10 (5V) via an external switch or relay. The maximum voltage should not exceed 28V.

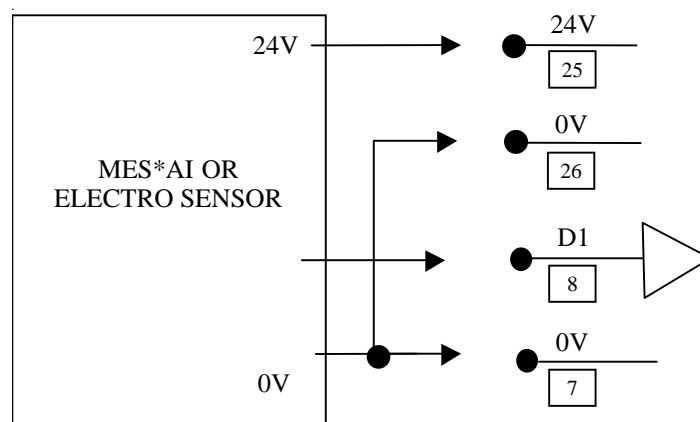

The trigger input is also compatible with the MOBREY Electrosensor sensors and head amplifiers. A 24V output is provided for this purpose. Typically this allows complete control of the desludge cycle by using a second sensor (Electrosensor) to start or stop the cycle. The terminal connections are shown above (note: it is important that the two 0V connections on terminals 7 and 26 are linked).



NOTE : When connected to these terminals the electrosensor sensors and head amplifiers MUST NOT be installed in explosive atmospheres.

MAINS SUPPLY

The unit can be powered either by 24V DC or by mains AC power. If both are connected, the unit will select the supply producing the highest internal 24V power rail. Select the AC Voltage as 115V or 230V using the selector slide switch above the AC line terminals.

Although the MSM400 meets all European standards for surge immunity on power and signal lines, it is recommended that lightning suppressors are fitted if local conditions make this advisable. Units manufactured by Telematic are suitable.

SAFETY PRECAUTIONS

A switch or circuit breaker should be installed in close proximity to the instrument, and labelled as such.

The unit must be earthed using the protective earth terminal 31.

INITIAL POWER UP

The unit will initially display the software revision number on Power up, and then revert to the standard display screen, showing a measured slurry/sludge density. If the sensor is in air, then this value will be high -the unit is effectively at full scale deflection.

5.0 PROGRAMMING

5.1 The operation of the MSM400 is controlled by means of programmable parameters. These are stored in memory and may be set by the user to define variables such as calibration scale factors, set points, and modes of operation. The parameters are accessed using the keypad, by means of a menu system as shown below. (Parameters may also be edited remotely using the HART protocol. See Appendix N). For a full listing of the menu structure refer to Appendix A1.

5.2 Navigation in the menu system

From the main display, pressing any key except ESC will enter the menu system. The top level menu contains the list of available menu items:

```
TOGGLE RUN
CALIBRATION
SETUP
MONITOR
```

To move up and down the list, use the UP and DOWN arrows until the required menu item is highlighted, then use the ENT or RIGHT arrow key to select it. The presence of additional menu items off the screen is indicated by up and down arrows on the right hand side of the display

The next level of the menu is then displayed and the required option can again be selected as above.

Continue until the required parameter is displayed and select it using the ENT key. (Note that menu groups are in upper case letters, parameters are in upper and lower case.)

The parameter may now be modified. Numeric values are edited one digit at a time, the LEFT and RIGHT arrows select each digit by highlighting them and the UP and DOWN arrows increment and decrement each digit. Some parameters e.g. "PV Units" are in the form of a list. These are edited in a similar way, selecting with the RIGHT arrow and using the UP and DOWN arrows to scroll through the list

When the displayed value is correct, press the ENT key to store it.

Scrolling

When a parameter is displayed but no digit is selected, the UP and DOWN arrow keys will scroll to the next parameter in numeric order. This provides an alternative method of accessing parameters without using the menu facility.

Example: Relay 1 set point programming.

To programme the relay, follow the simple steps shown below;

1. To alter any menu option the padlock icon in the top left of the display must be open. This is done using the TOGGLE RUN menu.
2. To access TOGGLE RUN from the normal display, press any key except ESC to display the main menu. The down arrow (↓) shown on the screen indicates that there are further options. (including MONITOR)

	MAIN MENU	0
	TOGGLE RUN	0
	CALIBRATION	↓
	SETUP	

- Use the down arrow key (β) to highlight the TOGGLE RUN option and select it using the “ENT” key. The TOGGLE RUN screen is then displayed:

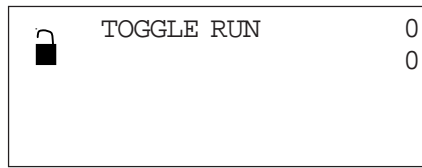

- To open (or close) the padlock press ENT as required. Press ESC to return to the main menu.
- Programming is now enabled.
- From the Main Menu screen, use the down arrow key (β) to highlight the SETUP option and select it using the “ENT” key
- In the SETUP menu use the β key to highlight the OUTPUT option and select it.
- In the OUTPUT menu use the β key to highlight the RELAY option and select it.
- The parameters associated with the relays are now shown.
- In the RELAY menu highlight the RELAY 1 MODE and select it using the “ENT” key.

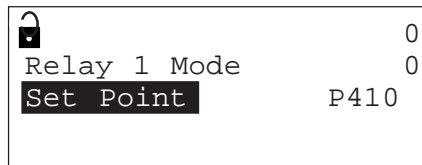

- Press the right key (P) to highlight the option.

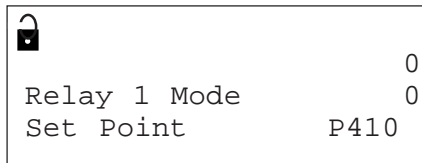

- Note; with the option highlighted pressing the up and down arrows scrolls through the available options.
- With the set point option highlighted press ENT to select. The highlighting now disappears.
- Pressing β will display the next item in the menu, RL1 On Point.

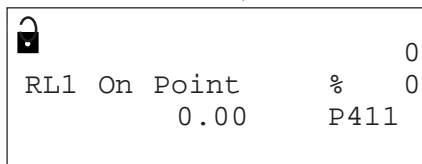

- This is a numeric parameter, therefore pressing P highlights the first digit that can be edited.

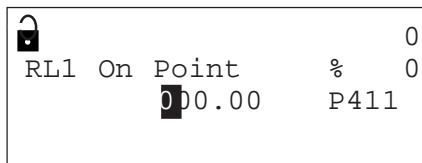

- Select the digit to be edited by pressing P as necessary.

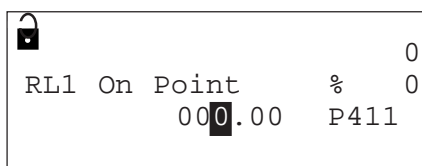

17. The value of the digit may now be incremented or decremented by pressing $\uparrow \downarrow$.

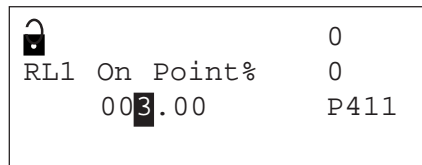

18. Press ENT to store the value. The highlighting will disappear. If an invalid number is entered then the display will revert to the last valid value.
19. The relay off point is programmed in the same way (all other numeric parameters are programmed in a similar way).
20. When programming is complete, return to the TOGGLE RUN menu and close the padlock.
21. Note; any programme changes will not alter the outputs, which remain frozen, until the TOGGLE RUN padlock has been closed.

5.3 DIAGNOSTIC PARAMETERS

Apart from the user-settable parameters described above, there is another set of diagnostic parameters, which display measured or calculated data to analyse and optimise system performance. These have the prefix “D” and cannot be modified.

5.4 EX-FACTORY SYSTEM FEATURES

The MSM400 Control Unit is supplied with default parameters that allow basic initial operation. The values and descriptions are listed in appendix two of this manual.

6.0 CALIBRATION

There are several methods for calibrating the MSM400, AUTOCAL and MANUAL ENTRY, these together with some important basic principles are explained below. Calibration always comprises two stages, zero setting and span setting. Zero setting calibrates the system so that the control unit indicates 0% solids in clear liquid. Span and lab value setting calibrates the system to monitor suspended solids accurately.

The recommended, simplest and most accurate method for calibrating the MSM400 is by using the AUTOCAL procedure, which is explained below.

6.1 ZERO SETTING

INITIAL ZERO

The MSM400 has the facility to warn the operator that the sensors require cleaning. The first zero calibration will be stored in initial zero reference parameter, “Init zero ref”. Future zero calibrations are compared with this value and any significant change will produce a warning message like the one shown below.

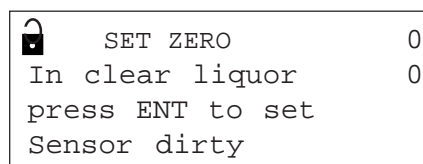

The actual difference required to produce this warning is programmed in dirty point (SETUP – ENGINEERING – SENSOR LIMITS – Dirty Pt). The default value is 0, which disables this feature. To enable the feature it is suggested that a value of approximately 6 dB is entered.

Note: this warning feature is not active until the first zero calibration has been carried out. To reset or clear initial zero value, ‘0’ must entered in Initial zero reference parameter (CALIBRATION – MANUAL ENTRY – ZERO REF – “Init Zero–1MHz” and “Init Zero–3MHz”, P123 & P124).

6.2 RECHECKING ZERO

It is recommended that the zero is checked regularly. The frequency of re-calibration is dependent on the process. However, it is suggested that this be done at least every 6 months.

CALIBRATION METHODS

AUTO CAL

6.3 AUTO CAL - ZERO SETTING PROCEDURE

AUTOCAL is a simple step by step calibration routine in which the user is guided through the calibration process by a series of user friendly screens. AUTOCAL is the recommended calibration procedure.

The attenuation of the ultrasonic signal in clean liquid varies slightly from sensor to sensor. For optimum system accuracy it is important to set up this zero loss accurately. When the system has been installed, immerse the sensors in the clearest liquid available. If this is not practical, choose a point in the cycle when the liquid in the gap between sensors has the lowest possible % suspended solids. For example on sewage treatment plants wash water would be acceptable.

Firstly enable access using the "TOGGLE RUN" command in the MAIN MENU.

Highlight the CALIBRATION option in the MAIN MENU by pressing the down arrow key.

```
┌───┐
│  ─┐  MAIN MENU      0
│  ─┘  TOGGLE RUN    0
│  ─┘  CALIBRATION
│  ─┘  SETUP
└───┘
```

Press ENT.

```
┌───┐
│  ─┐  CALIBRATION    0
│  ─┘  AUTOCAL        0
│  ─┘  MANUAL ENTRY
│  ─┘  Max %
└───┘
```

Highlight the AUTOCAL option by pressing the down arrow key, and press ENT.

```
┌───┐
│  ─┐  CALIBRATION    0
│  ─┘  AUTOCAL        0
│  ─┘  MANUAL ENTRY
│  ─┘  Max %
└───┘
```

Highlight the SETZERO option and press ENT. The following will show on the display.

```
┌───┐
│  ─┐  CALIBRATION    0
│  ─┘  SETZERO Max %  0
│  ─┘  SETSPAN
│  ─┘  LAB VALS
└───┘
```

Follow the instruction, the display will show the following

```
┌───┐
│  ─┐  SET ZERO      0
│  ─┘  In clear liquor  0
│  ─┘  Press ⇒
└───┘
```

The display will show the following.

```
🔒 SET ZERO      0
In clear liquor  0
please wait
```

After a few seconds the display will show the following.

```
🔒 SET ZERO      0
In clear liquor  0
Press ENT to set
23.1dB    26.2dB
```

The two dB values at the bottom of the screen are the zero values for the operating frequencies of the sensor (1MHz and 3.3MHz).

Once the ENT key is pressed the zero is set. All zero reference data is now saved together with the date of zero calibration. The screen now gives the option to re-do the zero setting or return to the AUTOCAL menu.

```
🔒 SET ZERO      0
Zero is now set  0
ESC to finish
ENT to re-do
```

6.4 AUTOCAL - SPAN SETTING PROCEDURE

The span setting measures the signal received from a representative sample of sludge. Later when the sludge is analysed and the results entered in the control unit the system automatically calculates the correct calibration factor (SLOPE).

If suitable slurry is not available an approximate calibration can be done using slurry types chosen from a list. This procedure is detailed in Section 6.10.

At least one span measurement must be taken. However, for better accuracy it is possible to take up to three span measurements and the MSM400 will calculate the average value.

Return to the AUTOCAL menu and highlight the SETSPAN option.

```
🔒 CALIBRATION  0
SETZERO Max %  0
SETSPAN
LAB VALS
```

Press ENT. The following is shown on the display

```
🔒 SET SPAN      0
In sample 1     0
Press ⇒
```

Now allow the normal or thickest (thickest is best) sludge which is to be metered, to cover the MSM400 sensor.

Press the ⇒ key the display will show.

```
🔒 SET SPAN      0
In sample 1     0
please wait
```

After a few seconds the display will show the following.

```

 SET SPAN          0
In sample 1          0
Press ENT to set
  33.6dB   44.2dB

```

The bottom line of the display shows the attenuation caused by the sludge. During a desludge these readings will fluctuate due to random variations in the sludge density. When the readings are reasonably stable press ENT at the same time that a sample is taken. This will store the reading from the sensor.

```

 SET SPAN          0
Span1 is now set    0
ESC to finish
↓ for Span2

```

Press the down arrow key to access the sample 2 and sample 3 screens (if required).

Repeat the above procedure for samples 2 and 3. The span is now set and ready for input of laboratory result (see later). When the sample procedure is complete press ESC until the normal display shows.

For best accuracy the three samples should be taken over a period of approximately 2 to 3 minutes.

The samples should now sent for laboratory analysis to establish the actual suspended solids content.

When the laboratory analysis results are available, the span calibration can be completed by entering the solids content (in % Solids) into "Lab Value 1" (P150).

If required, an estimated value can be used until the laboratory analysis results are available.

Note: Each time SPAN 1 is set the other two SPAN and LAB values are cleared and are not used until new Span2 and Span3 calibrations are carried out. The MSM400 calculates the average of all the valid span calibrations (a valid span calibration is one which has both a span 'N' and lab val 'N' value). The calibrations must be carried out in numerical order i.e. Span 1, then Span 2 and then Span 3. These values should be carried over a short period of time i.e. 2 to 3 minutes.

6.5 AUTO CAL LAB VALUES

To complete the AUTO CAL the samples must now be analysed and the results entered into the lab value menu. Access the LAB VALS menu by highlighting this option in the AUTOCAL menu and pressing ENT.

```

 LAB VAL          0
LabVal 1           0
LabVal 2
LabVal 3

```

Highlight the number of the LabVal to be entered and press ENT

```

 LAB VAL          0
LabVal 1           %   0
                   0.00 P150

```

Highlight the digit to be edited by pressing left or right arrows. To change the LabVal use the up and down arrows until the required value is showing, then use left or right arrow to move on to next digit. The units of this parameter are always % suspended solids. When the correct value is displayed press ENT to store the value. Repeat this step to input LabVal 2 and LabVal 3 if required (please note that better accuracy is achieved if all three samples and corresponding LabVals are entered). Press ESC until the normal display shows.

It is important to note that until the LabVal (1,2 or 3) are entered the system will use the default value of attenuation for the calibration.

6.6 MAXIMUM % SOLIDS

To complete the calibration and to enable the system to automatically select the optimum frequency of operation., it is necessary to set the maximum % solids that the system is required to measure. In the AUTOCAL Menu, select 'Max % Solids' (P 160) and enter the value required.

If the maximum % solids are low then the system will choose the higher operating frequency (3.3 MHz). This will give the best possible resolution. If the maximum % solids are higher than can be measured at 3.3 MHz then the system will automatically select the lower frequency (1 MHz). The figure for the maximum % solids that can actually be measured can be seen in MONITOR - DIAGNOSTICS - SENSOR – Max Measurable (D861)

The control unit is now calibrated and ready for operation.

6.7 CALIBRATION- Alternative calibration methods

Calibration is normally done via AUTOCAL. However, in special cases, if required, calibration can be done manually.

6.8 ZERO SETTING PROCEDURE

Firstly enable access using the "TOGGLE RUN" command in the Main menu. See section 5.2. Next, ensure that the frequency of operation corresponds to the frequency of the sensor by checking parameter D860 located in Monitor\Diagnosics\Sensor\Frequency. If necessary it can be changed. The relevant parameter is "Frequency" (P630) located in Set up\ Engineer\ . When the sensor is in "clear" liquid note the value of "Attenuation (D852) located in Monotor\Diagnosics\ Sensor.

To complete the zero setting, enter this value in the appropriate "Zero ref" parameter, located in Calibration\ Manual Entry\Zero ref.. "Zero ref A" (P120) is used for 1MHz sensors, "Zero ref B" (P121) is used for 3.3MHz sensors.

6.9 SPAN CALIBRATION/GRADIENT METHODS

There are three alternative ways of setting the gradient relationship between the measured attenuation and the % solids displayed (See Graph shown in Figure2). It is recommended that if AUTOCAL is not used then the Initial Setup should use Method 1: when later, figures are entered according to Methods 2 or 3, these automatically take priority over an original Method 1 calibration.

The **First** alternative method uses previous Mobrey experience of slurries/sludges, and the slurry type is chosen by name from a list. The MSM400 then uses the appropriate calibration line.

The Second alternative method uses actual site samples, and as such it is usually the most accurate calibration method. When the MSM400 reading is stable, a sample of slurry is taken for Lab analysis, and the attenuation measured at that time is recorded/entered in the MSM400 memory. Later the Lab result is also entered into a different location in the MSM400 memory, and the microprocessor computes the relationship.

The Third alternative method uses a known mathematical value of attenuation versus suspended solids for the slurry to be monitored from site experience on other tanks or other installations with the same sensor arrangement and slurry.

6.10 CALIBRATION METHOD 1-SLURRY TYPE

Enter the CALIBRATION option on the MAIN MENU screen. Then ENTER 'MANUAL ENTRY'. There are four selections possible here. Select SENSOR\ Sensor Gap and enter the space between sensor faces, in mm. This tells the MSM400 how big the sensor is, to relate it to memory figures of attenuation. Select SLUDGE TYPE (access through CALIBRATION, MANUAL ENTRY, SENSOR menu) and for Method 1 calibration select one of the listed types to suit the application. The unit will now work with this typical sludge calibration.

6.11 CALIBRATION-METHOD 2-SAMPLES

This Method of calibration offers the highest accuracy (and is used by AUTOCAL), since the MSM400 is set up based on actual site sample analysis. It does therefore require quite a lot of site work in taking samples, and analysing the solids %, to enter this later into the MSM400 microprocessor memory.

Under stable operating conditions, the objective is to record the MSM400 attenuation figure, and immediately take a sample of the slurry present between the sensor faces. This is then analysed in the lab, to derive the solids %, and this % value is later linked to the previous ultrasonic attenuation. The objective is to take three separate readings and samples, which are averaged by the Microprocessor.

Preferably the readings should be taken for a slurry concentration that is as high as possible, to give the best accuracy for the slope calculation. The three readings are date coded, and can all be separately inspected.

Ensure that the frequency is correct and that access is enabled as above. With the sensor in a stable representative slurry, note the value of the relevant "Span dB" which is the attenuation due to the suspended solids. This is the total attenuation minus the zero ref and is available in two parameters, Span dB @ A MHz (D854) for 1MHz sensor and Span dB @ BMH2 (D855) for 3.3MHz sensors. They are located in Monitor \ Diagnostics \ Sensor.

At the same time take a physical sample of the slurry for laboratory analysis by drying and weighing. Now enter the value of "Span dB" recorded, in the relevant "Span I @ 1MHz" (P130) or "Span I @ 3MHz" (P131) parameters. (accessed via Calibration / Manual Entry / Span)

When the laboratory analysis results are available, the span calibration can be completed by entering the solids content (in % Solids) into "Lab Value 1" (P150). -

(If required, an estimated value can be used until the laboratory analysis results are available.)

For improved accuracy up to three samples can be taken. These should be taken at roughly the same time and the "Span dB" noted for each one. The values are entered into the relevant Span 1, Span 2, Span 3 and Lab Value 1, Lab Value 2, and Lab Value 3 (accessed via Calibration / Manual / Entry / Lab Values). The MSM400 will automatically average as many values as are entered.

The MSM400 stores the calculated value of the slope in 0858 (1MHz) and D859 (3.3MHz) It is recommended that a note is made of this value. Note that the value of the frequency not being used is displayed as zero.

6.12 ATTENUATION VALUE-METHOD 3

Select the CALIBRATION /Manual Entry / Sensor to access the dB FACTOR value. This is the attenuation in dB per percent solids for the size/type of sensor and the slurry in use. Typically this data would have come from another installation of the same type, or previous data on this installation, read from the Diagnostic Display Data screens. Enter the numerical value required.

NB: It is advisable to recheck the zero setting on the plant periodically (Every 6 months at least).

7.0 PROGRAMMING THE MSM400 FUNCTIONS

DUTY (MODE)

DESLUDGE MODE.

There are several methods of starting, stopping, overriding and stopping early a de-sludge operation. The desired options can be selected in the SETUP – DUTY (Mode) – DESLUDGE menu. The following table explains the various options.

(PV = process value i.e. % suspended solids)

Start on	Stop on	Stop if	Do not start if
PV above level*	PV below level**	PV below level**	Digital i/p 2 low****
Digital i/p 1 low ***	Digital i/p 1 low ***	Digital i/p 1 low ***	
Time	Max Time		

Normally relay 1 is used for control purposes. Relay two is normally the alarm relay.

If selected, the desludge operation defaults to “Start on”– Time, “Stop on”– PV below a level.

“Do not start if” and “Stop if” are set to “none” (i.e. in default conditions these do not affect the desludge operation).

*	Above level is above Relay 1 or 2 On Point
**	Below level is below Relay 1 or 2 Off Point
***	Digital input 1 low for 1 sec, 2 sec, 5 sec, 10 sec, 15 sec, 20 sec, 30 sec, 40 sec, 50 sec, 60 sec, 90 sec, 120 sec, 180 sec, 240 sec & none
****	Digital input 2 low for 1 sec, 2 sec, 5 sec, 10 sec, 15 sec, 20 sec, 30 sec, 40 sec, 50 sec, 60 sec, 90 sec, 120 sec, 180 sec, 240 sec & none

The min and max times described in Set point operation also apply in de-sludge mode.

If it is required to set the control unit up to Start on Time then 4 parameters can be set up:-

1. Start time 1
2. Time interval 1
3. Start time 2
4. Time interval 2.

(Start time 2 and interval 2 default to not used.)

The time interval indicates the interval between de-sludges.

Start time 1 indicates the time of the first de-sludge operation. A de-sludge will always happen at this time each day independent of the time interval.

Start time 2 indicates the time of another fixed de-sludge time.

If either of the start times are set to 0:00 then the interval associated with that start time is not used.

If both of the time intervals are set to 0:00 then de-sludge only occurs at the start times.

The following table shows the default and limits of the time desludge operations.

No. of operation.	Set in (hrs & mins.)	Default value (hrs & mins)	Max value (hrs & mins)
Start time 1	hh:mm	8:00	23:59
Time interval 1	hh:mm	1:00	24:00
Start time 2	hh:mm	0:00	23:59
Time interval 2	hh:mm	0:00	24:00

Example:

In this example it is required to control the desludge operation as follows: Relay 1 will be used to open a discharge valve. Desludge cycles should start at fixed intervals. Each desludge cycle should stop on detection of thin sludge, thus preventing unwanted transfer of clear liquor. The “Stop if” function will also be used to stop the desludge using a digital input (i.e. an external trigger.) from a pump protection switch if the pump should fail. Typically in this example the sensor is mounted close to the bottom of a primary tank or in the discharge line.

Starting desludge

This is controlled by the “Start on” function in the DESLUDGE menu. This should be set to “Time”.

Cycles will begin at “Start Time 1” and repeat at intervals “Interval 1” until “Start Time 2”. After this, cycles will repeat at intervals “Interval 2”. This allows desludging to be done at different intervals during day and night, for example.

In the example “Start Time 1” is set to 7:30 and “Interval 1” to 5 hours. This will result in desludge cycles at 7:30, 12:30, 17:30, 22:30 and 03:30

Stopping desludge

This is controlled by the “Stop on” function in the DESLUDGE menu. This should be set to “PV<level” (PV = Process Variable, normally % solids)

Cycles will stop when the PV is less than “Relay 1 Off Point” in the RELAY menu.

In the example “Relay 1 Off Point” is set to 2%

Emergency stopping of desludge.

This is controlled by the “Stop if” function in the DESLUDGE menu. It should be set to “Ext Trig Xs” and the external trigger connected to the D1 trigger input. (The X indicates the number of seconds the input must be high to activate the function)

In the example “Stop if” is set to Ext Trig 2s

Related parameters.

“Relay N Max On Time” and “Relay N Min Off Time” may also be used to modify the basic commands described above.

Programming procedure.

1. From the normal display Press any key (except ESC) to access main menu (note; ensure TOGGLE RUN padlock is open).
2. Scroll down to the SETUP menu and press ENT.

```
┌───┐
│  ─┘  SETUP                0
│  ─┘  DUTY (Mode)         0
│      ─┘  INPUT            ↓
│      ─┘  OUTPUT
```

3. Scroll down to the DUTY (Mode) menu and press ENT.

```
┌───┐
│  ─┘  DUTY (Mode)         0
│  ─┘  PV CALCULATION     0
│      ─┘  Description      ↓
│      ─┘  Message
```

4. Scroll down to the DESLUDGE menu and press ENT.

```
┌───┐
│  ─┘  DESLUDGE           0
│  ─┘  Start On           0
│      ─┘  Stop On        ↓
│      ─┘  Do not start if
```

5. Scroll down to the Start On menu and press ENT.
6. Use ⇒ key to highlight the option, scroll down to the Time option and press ENT.

```
┌───┐
│  ─┘  Start On           0
│      ─┘  Time           P250
```

7. Press ESC to return to the DESLUDGE menu.

8. Scroll down to "Start time #1" and press ENT.
9. Use ⇒ key to highlight the first digit in the time, scroll up and down to edit the digit. Use the left and right arrows to move to the next digit (the time is programmed in hours and minutes h : m). When the correct start time is shown on the display press ENT.

			0
Start Time	#1	h:m	0
	7:30		P254

10. Press ESC to return to the DESLUDGE menu.
11. Scroll down to "Interval #1" and press ENT.
12. The interval is the time that the control unit waits between the end of one desludge and the start of the next. To set the interval use ⇒ key to highlight the first digit in the interval, scroll up and down to edit the digit. Use the left and right arrows to move to the next digit (the time is programmed in hours and minutes h : m). When the correct interval is shown on the display press ENT.
13. Press ESC to return to the DESLUDGE menu.
14. Scroll to "Stop on" and press ENT.
15. Use ⇒ key to highlight the option, scroll to the "PV<level" (P251) option and press ENT.
16. Press ESC to return to the DESLUDGE menu.
17. Scroll down to "Stop if" and press ENT.
18. Use ⇒ key to highlight the option, scroll down to the "Ext Trig Ns (P252)" option and press ENT. Where N = the number of seconds that the digital input must be active before the control unit stops the desludge. This value is chosen from a list by scrolling, picking the desired time and pressing ENT.

			0
Stop if			0
Ext Trig	2s		P252

The times available are digital input 1 active for 1 sec, 2 sec, 5 sec, 10 sec, 15 sec, 20 sec, 30 sec, 40 sec, 50 sec, 60 sec, 90 sec, 120 sec, 180 sec, 240 sec & none.

19. Press ESC three times to return to the SETUP menu.
20. Scroll down to OUTPUT and press ENT.
21. Scroll down to RELAY and press ENT.
22. Scroll down to "RELAY 1 Mode" and press ENT.
23. Use ⇒ key to highlight the option, scroll down to the "Desludge" (P410) option and press ENT.
24. Press ESC to return to the RELAY menu.
25. Scroll down to RL1 Off Point and press ENT.
26. Use ⇒ key to highlight the first digit to be edited, scroll up and down to edit the digit. Use the left and right arrows to move to the next digit (the off point is programmed in % suspended solids). When the correct value is shown on the display press ENT.
27. Return to the TOGGLE RUN menu and lock the padlock by pressing enter.
28. The system is now in desludge mode.

7.1 OUTPUTS

7.2 CURRENT OUTPUT

The operation of the current output is set up by four different parameters and is always controlled by the process variable (PV), which is normally % suspended solids. These are found in SETUP – OUTPUT – CURRENT OUTPUT.

1. Lower range value (Low range val)
This is the value of PV which corresponds to the minimum current output, either 0 or 4mA
2. Upper range value (Up range val)
This is the value of PV which corresponds to the maximum current output, 20mA.
3. Alarm action
This is the value to which the current output is driven under alarm conditions and is selectable from a list.
 - 3.6mA
 - 21mA
 - Hold (i.e. hold last reading)
For alarm conditions see the section below titled ALARM.
4. 0-20mA or 4-20mA setting (0/4-20mA)
This parameter sets the current output range to either 0-20mA or 4-20 and is selected from a list.
5. If required the 4-20mA can be trimmed using an external calibration meter. (For details see Section 7.8)

7.3 RELAY OPERATION

The MSM400 controller offers various options for operating the relays.

There are 2 relays that are programmable to different modes, set point operation, de-sludge, alarm and fault. The mode of operation is selected through the SETUP – OUTPUT – RELAY – Relay Mode menu. The default mode for Relay 1 is set point operation and Relay 2 default mode is alarm.

a) SET POINT OPERATION

It is possible to program both relays for set point operation. These are found in SETUP – OUTPUT – RELAY. The process value (PV) controls the relays.

1. Relay on point (RL* On Point)
This is the value of PV at which each relay will turn on
2. Relay off point (RL* Off Point)
This is the value of PV at which each relay will turn off
3. Relay minimum on time (RL* Min ON)
This is the minimum time that the relay will stay on for and this takes priority over the maximum on time.
4. Relay maximum on time (RL* Max ON)
This is the maximum time that the relay will stay on for.
It is important to note that this function only operates when the minimum off time is set to a non zero value.
5. Relay minimum off time (RL* Min OFF)
Once the relay has turned off this is the minimum time before the relay will turn on again.
(* = 1 or 2 i.e. relay one or two)

If both on and off parameters are set to zero then relay is turned off.

If the on and off points are equal (non-zero) the relay is on when PV is above the set point and off when below.

If both minimum and maximum on times are set to zero (default) then they are not used.

(See also the example in “NAVIGATION IN THE MENU SYSTEM”).

b) DESLUDGE

When in desludge mode the relays operate as explained above.

c) ALARM

The relays can be set for alarm mode conditions by selecting the option in SETUP – OUTPUT – RELAY – Relay * mode. See the section below titled ALARM.

7.4 ALARM

There are six different alarms in the SETUP - OUTPUT - ALARM menu. Each alarm can be set to operate a relay, or drive the current output, or both, or neither to the following states.

1. Current output - 3.6mA, 21mA, Hold as defined in "Alarm action" in the CURRENT OUTPUT menu.
2. Relay outputs – The relays energise in the alarm condition

The relays or current output must be set up for alarm or fault action for this function to operate. The effects of each alarm action are shown in the list below :

1. Memory fault
2. PV out of limits
3. Current saturated
4. Temperature out of limits - this refers to the temperature within the control housing.
5. Digital input 1 active

7.5 DISPLAY

The display has 3 sections which can be programmed to display a selection of variables. Each section has a parameter which is used to select the variable which is displayed. They are located in SET-OUTPUT-DISPLAY. The required option is selected from the list as shown below.

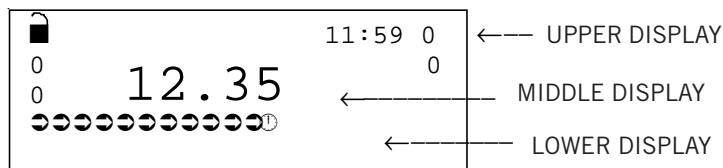

Display option parameter number	Description
D800	PV process value
D801	Sludge density
D805	% Current out
D806	Current output (mA)
D821	RL1 run time
D822	RL2 run time
D844	Control unit temperature
D850	Attenuation at 1 MHz
D851	Attenuation at 3.3 MHz
D860	Sensor frequency
P730	Date
P731	Time
Bargraph	Please note that the bargraph only works on the lower display and it shows % current output.

7.6 BACKLIGHT

The display has a backlight, which can be set to On, Off or Auto. When set to Auto the backlight automatically turns off after a few minutes if no keys are pressed.

7.7 ENGINEERING

FREQUENCY SET

The frequency of operation is normally set automatically. Under certain conditions it may be advantageous to force the control unit to operate at either 1 MHz or 3.3 MHz. This should not be done without consulting the factory.

7.8 SYSTEM

TEST – CURRENT OUTPUT

The current output is calibrated in the factory and should not require any adjustment. However, if required, it is possible to adjust the 4mA and 20mA points using a calibrated meter. This is done by following the procedure below.

1. Connect a millammeter to the current output terminals (No. 16 and No. 18).
2. Ensure the toggle run padlock is open.
3. Access the SETUP – SYSTEM – TEST – CURRENT OUTPUT MENU.
4. Select either the “4mA out adjust” or the “20mA out adjust” and press ENT.
5. Read the actual current on the calibrated meter.
6. Enter this value in the chosen parameter and press ENT.
7. Check that the actual current is now exactly 4mA or 20mA.

For diagnostic purposes the current output can be driven to any value between 4mA and 20mA (SETUP – SYSTEM – TEST – CURRENT OUTPUT – Set current). With a suitable meter connected to the current output terminals a value can programmed on the control unit and the same value will appear on the meter. This programmed current will remain until the toggle run padlock is closed.

SETTINGS

Keypad sound

The keypad sound can be turned on or off according to the users preference. It is controlled by SETUP – SYSTEM – SETTINGS – Keypad sound.

8.0 HART SMART Communications

The MSM400 is compatible with the HART digital signalling system, either as well as the 4-20 mA output , or on a Bus system. MSM400 supports Version 5.x of the HART protocol, and is fully supported by the MOBREY CK-1 HHC (Hand Held Communicator) and by the UNIVERSAL 275 HHC. It is normally necessary to load the Universal HHC with the transmitters Device Description to access anything more than the basic transmitter information-contact Mobrey Measurement for details. The MSM400 can also communicate with the MOBREY H-View PC based system.

Normal requirements of the loop impedance apply to allow the HHC to communicate properly. The MSM400 has a built in 270 ohm load, which can be selected if required-see section 4.6. This section also shows the special terminals in the MSM400 terminal compartment available for connection of a HHC across the current output. The MSM400 Cn number in relation to HART circuits is 1.

Please consult the HHC manual to see how to interrogate the Universal and Transmitter specific parameters.

The HART messages and Transmitter/Sensor ID Numbers are accessed and set up (where allowed) by the operator on the INFORMATION Structure, APPLICATION+CONTROL UNIT+SENSOR screens. Some of this data is factory preset, and is not alterable, to make the MSM400 identifiable to Universal communicators. But the main Description, Tag Number and Message should be used to identify the equipment and the actual site application for site operator use.

The Normal Universal Commands are always available over the HART interface---

- PV-Process Value
- % of current output (% of FSD)
- Actual mA current output being transmitted
- Alarms active
- Temperature (inside the electronics housing)
- PV for 0 or 4 mA output as programmed
- PV for 20 mA output as programmed
- PV units of measurement
- Time Damping used on the measurement
- Description (Customer supplied)
- Message (Customer supplied)
- Tag Number (Customer supplied)

9. MAINTENANCE / INSPECTION

9.1 Spares

The MSM400 is a factory built in instrument and apart from the mains fuse there are no spare parts that can be fitted in the field. Should the MSM400 require any repair or replacement parts, it must be returned to Mobrey Measurement for action.

CONTROL UNIT

No maintenance is required beyond occasional cleaning of the enclosure with a damp cloth. Solvents or bleaches should not be used. The fuse may only be replaced with the same type and rating. Do not modify or attempt to repair the unit.

SENSORS

No maintenance is required beyond occasional cleaning. The frequency of cleaning will be determined by experience. A message warning that cleaning is required may be generated when performing routine zero calibrations. Refer to Section 6.1

FULL MENU STRUCTURE - LOCATION OF PARAMETERS

APPENDIX A1

MAIN MENU	SUB MENU 1	SUB MENU 2	PARAMETER DESCRIPTION	Par No.	
TOGGLE RUN CALIBRATION (specific)	AUTOCAL		Toggle		
			SET ZERO	L125	
			SET SPAN	L126	
			LAB VALUES	L127	
			Max % solids		
	MANUAL ENTRY	SENSOR		Sensor Gap	P100
				Sludge Type	P101
				dB Factor @ 1MHz	P102
				dB Factor @ 3MHz	P103
		ZERO REF		Zero Ref @ 1MHz	P120
				Zero Ref @ 3.3MHz	P121
				Date of Zero Ref	P122
				Initial Zero Ref @ 1MHz	P123
			Initial Zero Ref @ 3.3MHz	P124	
		SPAN		Span 1 @ 1MHz	P130
				Span 1 @ 3.3MHz	P131
			Span 2 @ 1MHz	P132	
	Span 2 @ 3.3MHz		P133		
	Span 3 @ 1MHz		P134		
	Span 3 @ 3.3MHz		P135		
	Date for Span 1	P140			
	Date for Span 2	P141			
	Date for Span 3	P142			
LAB VALUES		Lab Value 1	P150		
		Lab Value 2	P151		
		Lab Value 3	P152		
		Max % Solids	P160		
SETUP	DUTY (Mode)	PV Calculation	PV Units	P200	
			Density Units	P201	
			Description	P240	
			Message	P241	
		Tag	P242		
		DESLUDGE	Start On	P250	
	Stop On		P251		
	Do not Start if		P252		
	Stop If		P253		
	Start Time #1		P254		
	Interval #1	P255			
	Start Time #2	P256			
	Interval #2	P257			
	INPUT	SENSOR INPUT	Serial Number 1	P300	
			Type 1	P301	
			Damping 1	P302	
	OUTPUT	CURRENT OUTPUT	Lower range value	P400	
			Upper range value	P401	
			Alarm action	P402	
0-20mA/4-20mA			P403		
RELAY		Relay 1 mode	P410		
		Relay 1 On Point	P411		
		Relay 1 Off Point	P412		
		Relay 1 Min On Time	P413		
		Relay 1 Max On Time	P414		
		RL 1 Min Off Time	P415		
Relay 2 mode	P420				
Relay 2 On Point	P421				
Relay 2 Off Point	P422				
Relay 2 Min On Time	P423				
Relay 2 Max On Time	P424				
RL 2 Min Off Time	P425				

MAIN MENU	SUB MENU 1		SUB MENU 2	PARAMETER DESCRIPTION	Par No.	
SETUP (Contd)			ALARM	Memory Fault Alarm PV Out of Limits Current Saturated Temperature Out of Limits Logging Memory Filling Digital Input 1 Active	P540 P541 P542 P543 P544 P545	
			DISPLAY	Display Select 1 (upper) Display Select 2 Display Select 3 Backlight On/Off	P570 P571 P572 P575	
	LOGGING			Interval Fast Log Select Overwrite Old	P590 P591 P592	
	ENGINEERING (setup)		SENSOR LIMITS	Frequency Min dB Max dB Sensor Dirty Threshold	P630 P640 P641 P642	
	SYSTEM	TEST	CURRENT OUTPUT	4mA output adjust 1 20mA output adjust 1 Set Current 1	P700 P701 P702	
		SETTINGS		Date Time Keypad Sound On/Off	P730 P731 P735	
		FIXED		Model Code Serial Number Hardware Version Software Revision	D750 D751 D752 D753	
			HART	Manufacturer's Code Unique ID Universal Command Rev TS Command Rev Preamble Bytes Flags	D760 D761 D762 D763 D764 D765	
	MONITOR	READINGS			PV(process variable) SV (Sludge Density) % Current Output 1 Current Output 1 Totaliser	D800 D801 D805 D806 D810
				RELAY		
RELAY RUN TIMES				Relay 1 Run Time Relay 2 Run Time	D821 D822	
ALARM REPORT					D830	
DIAGNOSTICS		Sensor	Digital input status Temperature Attenuation @ 1MHz Attenuation @ 3.3MHz Attenuation unsmoothed Signal level (Raw A/D bits) Span Average @ 1MHz Span Average @ 3.3MHz Sample Average @ 1MHz Sample Average @ 3.3MHz Slope 1 Slope 3 Frequency of operation Max. density measurable	D835 D844 D850 D851 D852 D853 D854 D855 D856 D857 D858 D859 D860 D861		

APPENDIX A2: FULL LIST OF FUNCTIONS

Parameter list and description

P=Parameter, D=Diagnostic Display Parameter

Parameter No.	Description	Min value	Max value	Default Ex-Factory
P100	Sensor Gap in mm. This is a user entered parameter (optional). This value is ignored when an alternative span calibration is carried out (i.e. method two or three).	0	1000	0.0
P101	Sludge type The user can select from a list of sludge type to set up the span for the calibration procedure (optional). Each sludge type is associated with an attenuation factor for each frequency. This value is ignored when an alternative span calibration is carried out (i.e. method two or three).	-	-	none
P102	dB Factor @ 1MHz A user alterable parameter. This is the attenuation number in dB/% at 1MHz. This is used for the span calibration (method three).	0	-	0.000
P103	dB Factor @ 3.3MHz A user alterable parameter. This is the attenuation number in dB/% at 3.3MHz. This is used for the span calibration (method three).	0	-	0.000
P120	Zero Ref @ 1MHz This is the value in dBs (@ 1MHz) that is stored in the control unit when a zero calibration is carried out. This value is over written each time a zero calibration is carried out.	-	-	16
P121	Zero Ref @ 3.3MHz This is the value in dBs (@ 3.3MHz) that is stored in the control unit when a zero calibration is carried out. This value is over written each time a zero calibration is carried out.	-	-	16
P122	Date of Zero Ref This is automatically stored by the control unit when the zero calibration is done. The actual date can be set-up in the ENGINEER menu (P730)	-	-	--/------
P123	Initial Zero Ref @ 1MHz dB's This is the value in dBs (@ 1MHz) that is stored in the control unit when the initial zero calibration is carried out. This value is compared with subsequent zero calibrations. 0 must be entered to reset or clear initial zero value	-	-	0
P124	Initial Zero Ref @ 3.3MHz dB's This is the value in dBs (@ 3.3MHz) that is stored in the control unit when the initial zero calibration is carried out. This value is compared with subsequent zero calibrations. 0 must be entered to reset or clear initial	-	-	0

Parameter No.	Description	Min. value	Max. value	Default Ex-Factory
P130	Span 1 @ 1MHz Measured attenuation	-	-	0.0
P131	Span 1 @ 3.3MHz Measured attenuation	-	-	0.0
P132	Span 2 @ 1MHz Measured attenuation	-	-	0.0
P133	Span 2 @ 3.3MHz Measured attenuation	-	-	0.0
P134	Span 3 @ 1MHz Measured attenuation	-	-	0.0
P135	Span 3 @ 3.3MHz Measured attenuation	-	-	0.0
P140	Date for Span 1	-	-	0
P141	Date for Span 2	-	-	0
P142	Date for Span 3	-	-	0
P150	Lab Value 1	-	-	0
P151	Lab Value 2	-	-	0
P152	Lab Value 3	-	-	0
P160	Max % Solids	-	-	-
P200	PV Units The PV units can be selected from a list (%, kg/hr, lb/hr,g/l, ppm, None)	-	-	%
P201	Density Units	-	-	%
P240	Description 16 character user-defined description of application, say.	-	-	-
P241	Message User set up message for HART info	-	-	MSM400 MONIT 32 Chars
P242	Tag Number - Control Unit User-defined alpha-numeric entry up to 32 characters in accordance with HART. May be entered by keypad.	-	-	- MSM40055
P250	Start On This parameter is used to set up the mode of start for a desludge operation and is selected from a list (Time, PV, Ext. Trig)	1	3	none
P251	Stop On This parameter is used to set up the mode of stop for a desludge operation and is selected from a list (Time, PV, Ext. Trig)	1	3	none
P252	Do not Start if This parameter is used to set up the mode 'do not start if' for a desludge operation and is selected from a list (Light sludge, Ext trigger)	1	3	not used
P253	Stop If select from list This parameter is used to set up the mode 'stop if' for a desludge operation and is selected from a list (Light sludge, Ext trigger)	1	3	not used
P254	Start Time #1 The time of day that the first desludge cycle starts	00:00	23:59	7:00
P255	Interval #1 The time interval for the first desludge cycle	00:00	23:59	1:00
P256	Start Time #2 The time of day that the second desludge cycle starts	00:00	23:59	00:00
P257	Interval #2 The time interval for the first desludge cycle	00:00	23:59	00:00
P258	Max retries	Not implemented		
P300 P	Sensor Serial Number User-settable	-	-	-
P301 P	Sensor Type	-	-	-
P302	dB Damping	-	-	-

Parameter No.	Description	Min. value	Max. value	Default Ex-Factory
P400	Lower range value The mA set point for minimum PV in selected units	-	-	0
P401	Upper range value The mA set point for maximum PV in selected units	-	-	auto
P402	Alarm action The is the value that the current will drive to on alarm action. The alarm action is programable and is selected from list (3.6/21mA/hold last reading).	1	3	hold
P403	0-20mA/4-20mA The mA output is selectable by user, either 0 or 4 to 20mA	1	2	4-20mA
P410	Relay 1 Mode Select Relay function from a list (Off, Set Point,Desludge Alarm, Totaliser, Fault)	1	5	set point
P411	Relay 1 On Point The value of the variable (as set in relay mode parameter) at which relay 1 turns on. Programmable by user	-	-	0
P412	Relay 1 Off Point The value of the variable (as set in relay mode parameter) at which relay 1 turns off.	-	-	0
P413	Relay 1 Min On Time A programmable parameter for the minimum on time of relay 1. This is to overcome slugs of clear liquor at the start of desludge cycles	0:00	999.59	000:00
P414	Relay1 Max On Time A programmable parameter for the maximum on time of relay 1. This is to ensure, for example, a pump does not continue to run due to a faulty signal from sensor.	0:00	999.59	000:00
P420	Relay 2 Mode Select Relay function from a list (Off, Set Point,Desludge Alarm, Totaliser, Fault)	1	5	set point
P421	Relay 2 On Point The value of the variable (as set in relay mode parameter) at which relay 2 turns on. Programmable by user	-	-	0
P422	Relay 2 Off Point The value of the variable (as set in relay mode parameter) at which relay 2 turns off. Programmable by user	-	-	0
P423	Relay 2 Min On Time A programmable parameter for the minimum on time of relay 2. This is to overcome slugs of clear liquor at the start of desludge cycles	0:00	999.59	000:00
P424	Relay 2 Max On Time A programmable parameter for the maximum on time of relay off. This is to ensure, for example, a pump does not continue to run due to a faulty signal from sensor.	0:00	999.59	000:00
P415	Relay 1 Min Off Time	-	-	-
P425	Relay 2 Min Off Time	-	-	-

Parameter No.	Description	Min. value	Max. value	Default Ex-Factory
P540	Memory Fault Alarm If the control unit detects a memory fault	0	3	both
P541	PV Out of Limits If the Pv is out of limits then an alarm can be reported by a relay, current output or by both	0	3	both
P542	Current Saturated If the current is saturated is out of limits then an alarm can be reported by a relay, current output or by both	0	3	none
P543	Temperature Out of Limits If the temperature is out of limits then an alarm can be reported by a relay, current output or by both	0	3	none
P545	Digital Input 1 Active	-	-	-
P570	Display Select 1 (upper) This parameter designates what is shown on the upper display and can be selected from a list (PV, %, clock)	1	-	- Time
P571	Display Select 2 (mid) This parameter designates what is shown on the mid display and can be selected from a list (PV, %, clock)	1	-	- PV
P572	Display Select 3 (lower) This parameter designates what is shown on the lower display and can be selected from a list (PV, %, clock)	1	-	- bar graph
P575	Backlight On/Off	-	-	-
P630	Set Frequency of Operation High, Low or Auto	-	-	-
P640	Min dB	-	-	-
P641	Max dB	-	-	-
P642	Sensor Dirty Threshold A user alterable value in dBs. The control unit compares successive zero calibrations and if the difference exceeds this value then the control unit displays the warning 'CHECK SENSOR CLEAN'.	0	-	0
P700	4mA output adjust Factory calibrated. The user can adjust the 4mA output via the up down arrows	-	-	735
P701	20mA output adjust Factory calibrated. The user can adjust the 20mA output via the up down arrows	-	-	3194
P702	Set Current Force current to a value to check loop equipment	-	-	0
P730	Date	-	-	-
P731	Time	-	-	-

Parameter No.	Description	Min. value	Max. value	Default Ex-Factory
D750	Model Code Hart parameter	-	-	-
D751	Serial Number - Control Unit	-	-	-
	Store as Final Assembly Number (FAN)			
D752	Hardware Revision	-	-	-
	Factory-set			
D753	Software Revision	-	-	-
	Factory-set, embedded in software			
D760	Manufacturer's Code	-	-	-
	Factory set not alterable			
D761	Unique ID	-	-	-
	Hart parameter			
D762	Universal Command Revision	-	-	-
	Hart parameter			
D763	Transmitter Specific Command Revision	-	-	-
	Hart parameter			
D764	Preamble Bytes	-	-	-
	Hart parameter			
D765	Flags Hart parameter	-	-	-
D800	PV	-	-	-
D801	Sludge Density	-	-	-
D805	% Current Output	-	-	-
D806	Current output Current is proportional to PV	-	-	-
D810	Totaliser Value	-	-	-
D820	Relay Status	-	-	-
D821	Relay 1 Run-Time Resettable - Hours & Minutes	-	-	-
D822	Relay 2 Run-Time Resettable - Hours & Minutes	-	-	-
D830	Alarm report e.g. Sensor Fault,	-	-	-
D835	Digital input status	-	-	-
D841	Current input	-	-	-
	Value of current input (mA)			
D844	Temperature	-	-	-
	The temperature °C within the control unit			
D850	Attenuation @ 1MHz Attenuation	-	-	-
D851	Attenuation @ 3.3MHz Attenuation	-	-	-
D852	Attenuation unsmoothed	-	-	-
D853	Signal level (Raw A/D bits)	-	-	-
	Raw RF A/D output			
D854	Span Average @ 1MHz (dB)	-	-	-
	Diagnostic parameter that averages the span calibrations			
D855	Span Average @ 3.3MHz	-	-	-
	Diagnostic parameter that averages the span calibrations			
D858	Slope 1	-	-	-
	The value of the attenuation in dB/% @ 1MHZ determined by the control unit.			
D859	Slope 3	-	-	-
	The value of the attenuation in dB/% @ 3.3MHZ determined by the control unit.			
D860	Frequency of operation	-	-	-
	Diagnostic of frequency(ies) being used (MHz)			
D861	Maximum density	-	-	-
	The maximum density that can be measured.			
	This value is calculated from zero and span data.			

APPENDIX A3 : HART and PSION Operating Instructions

1.0. HART CONSIDERATIONS

Special Considerations for HART

If the HART communications facility built into the control unit will be used at the time of installation or during its future working life, then it is essential that a resistive load of at least 250 Ohms is connected in the supply cable. This may be provided by other devices in the loop (Chart recorder, meter, etc.) or more usually by installing a standard 270 Ohm 0.25W resistor in series with control unit. In this way the master device will be able to signal to the control unit without the power supply short-circuiting the data.

In addition, excessive cable capacitance will attenuate the HART signalling and so the capacitance must anyway be limited if HART communications is to be used. The RC time constant for the network must not exceed 65µs, e.g. if the network resistance is, say, 650Ω then the maximum network capacitance is 0.1µF.

HART transmitters are often given a Cn number where n is the multiple of 5000pF which the device presents to the network. In the case of MSM400 the value of n is 1 since its capacitance is below 5000pF.

Total loop resistance and capacitance

Additional equipment such as indicators or recorders may be inserted in the loop subject to the resistance and capacitance limits discussed above.

Cable trays

It is recommended that HART signal cables are not run alongside power cables.

1.1 Multi-drop installations (MSM400 in HART digital mode)

Up to 15 transmitters may be connected in parallel with each other, and each must be set to a different HART address between 1 and 15. When HART transmitters are connected in multi-drop mode, each control unit draws a fixed current of 4mA.

Compatibility with other HART instruments.

Any HART instrument, regardless of the manufacturer, may be connected in parallel with another to create a multi-drop network. They may be combined with separately powered, current sourcing or sinking devices but care must be taken to ensure that the HART signal current passes through the 250Ω minimum impedance to establish communications. For full details of HART instrument availability, refer to the HART Communication Foundation publications or individual manufacturers' literature.

Handheld Communicators

A handheld communicator (HHC) may be connected across the network (downstream of the minimum 250 Ohm loop resistance) to programme or interrogate a HART control unit. Some HHC's support only a subset of a transmitter's functions, and will thus only access the control units Universal and Common Practice commands. However, the MSM400 is fully supported by the MOBREY-CK1 HHC and by the UNIVERSAL 275 HHC (provided the 275 is loaded with the transmitter's Device Description – contact Mobrey Measurement or the HART Communications Foundation for details).

2.0 SMART COMMUNICATION WITH THE MOBREY MSM400

With a SMART HHC, you can make adjustments and calibrate your MSM400 at any point on the two wire connection to the control unit. You can also make many other adjustments and obtain operational and diagnostic information using the HHC.

Alternatively, Mobrey have a PC based software package called Mobrey H-View which allows you to make adjustments and obtain readings through a standard PC. Contact Mobrey or your local agent for details.

If you have a Mobrey type CK HHC (Psion Organiser based) and the appropriate datapak, refer now to Appendix D for details of assembly, connection and menu structure before reading on to the specific adjustments listed below.

If you have another type of SMART communicator or computer based software tool, you must ensure that the MSM400 Device Description (DD) is correctly loaded or compiled to gain access to all of the MLT parameters. If you do not have the MSM400 DD loaded, you will only be able to access the Universal and Common Practice commands.

Contact or any other HART Host Subscriber to update your communication device with the latest MSM400 DD.

The MSM400 control unit is a SMART instrument using the HART protocol to communicate with external devices.

The Mobrey HHC is a hand-held organiser based communication device fitted with a HART interface to allow communication with Mobrey HART instruments.

By connecting the HHC across the two wire loop at any point downstream of the minimum 250 Ohm loop resistance, communication can be established. The MSM400 has integral test pins provided for this purpose. Refer to Appendix D3.0 for details of HHC connection and operation.

The following paragraph details how to re-range and change damping using the HHC once communication with the MSM400 has been established.

2.1 Calibration adjustments at operating conditions.

Important note : Making changes to the position or span of the 4-20mA range with a communicator can cause the control unit to make step changes in the output. You should arrange to set your plant control loop to "Manual" before making changes if this could be a problem.

4mA point – from the "Program" menu / "Calibrate" sub-menu, access Parameter P500. The factory default value is "0".

Enter the desired new value of the PV (Process Value), normally the sludge level in % solids, required to give a 4mA output, and confirm when prompted by pressing the "exe" key that this is correct. The new value is now entered and saved.

Note, the 4mA point can be positioned above the 20mA point to reverse the operation of the control unit, thus giving a falling current output with rising sludge level.

20mA point – from the "Program" menu / "Calibrate" sub-menu, access Parameter P501. The factory default value is "A". This represents "Automatic" and in this case means that the 20mA point is automatically set to the maximum range of the control unit.

Enter the desired new value of the PV (Process Value), required to give a 20mA output, and confirm when prompted by pressing the "exe" key that this is correct. The new value is now entered and saved.

Damping – from the "Program" menu / "Engineer" sub-menu, access parameter P625. The factory default value is 5s.

Enter the desired new value in seconds and press "exe" to confirm and save the new value.

2.2 Further customisation using the SMART HHC

There are some other features of the control unit that can be changed at this stage:

Identity

The following parameters can be recalled from the “Info” menu, and those shown * below can be site configured :-

P701	MESSAGE	*general purpose 32 character message
P710	TAG	*control unit identifier (8 characters)
P700	DESCRIPTION	*E.G. control unit application or location (16 char)
P702	DATE	Automatically updated on exit if changes made
P722	FINAL ASSY No.	Factory set – hardware assembly number
P760	SENSOR SERIAL No	Factory set – LVDT serial number
P660	PASSWORD	* 3 level password system.

Simply enter any message or tag number as appropriate and the control unit will retain this information in memory for future identification. This is particularly useful if you are likely to interrogate the control unit using the HHC from a remote location.

Refer to Appendix D for more detailed information.

Units of Operation and Display

The units displayed on the display or the HHC when used can be changed from the default “%” using P610 accessible through the “Program”Engineer sub-menu.

D. HANDHELD COMMUNICATOR – MOBREY – CK***D.1.0. Hand Held Communicator – Assembly Instructions**

The MOBREY-CK* SMART Hand Held Communicator is supplied as a kit of items (Figure DI) which are assembled as follows:

- D.1.1 Remove the lower sliding cover (1) of the Psion organiser (2) completely to expose the battery compartment lid (3) at the base of the keypad, and the two slots for Datapaks behind the right hand side of the keypad.
- D.1.2 Remove the lower of the two blank Datapak mouldings and insert the preprogrammed Mobrey SMART Datapak (4), pressing the unit home. This lower slot is the “C” slot in Psion Organiser memory.
- D.1.3 Remove the battery compartment lid (3) and insert the 9V battery (5), positive terminal first. Replace the battery compartment lid (3) and the lower sliding cover (1) over the base of the Psion Organiser. Leave the keyboard exposed.
- D.1.4 At the top of the Psion Organiser above the LCD, slide the cover across to the right to expose the connector. Insert the MOBREY SMART interface unit (6) in this slot.
- D.1.5 The lead used to connect the MSM400 cabling is plugged into the MOBREY SMART interface unit. On the MOBREY-CK1 and MOBREY-CK3 this is via a 3.5mm jack plug. On the -CK2 a multi pin plug is used. The latter also has the hook-on connectors built into the leads instead of push on crocodile clips.
- D.1.6 The MOBREY SMART Interface Unit has another socket at the top left hand side for connection of a standard Psion external power unit as an alternative to battery operation.

D.2.0. Notes

- D.2.1 Although it is possible to insert two Datapaks into the HHC, this is not recommended as a conflict between them can occur.
- D.2.2 The MOBREY-CK* Datapaks enable communication with both MSP100 ultrasonic level transmitters and MSM400 displacement level transmitters, and also gives generic support for all other HART transmitters.
- D.2.3 When not in use, remove the Mobrey SMART Interface unit from the HHC to prolong battery life.
- D.3.0. Requirements for loop powered SMART Operation (Refer to Fig. DII)
- D.3.1 The MSM400 control unit requires a DC supply voltage of 2.5 volts at its terminals for satisfactory operation (V3).
- D.3.2 Resistance between any two SMART Interface connection points must exceed 250 ohms. (R1).
- D.3.3 For the minimum DC supply voltage (V1) to be calculated, the voltage drops in the loop at 20mA must be assessed. The absolute minimum value of V1 will therefore be 7.5 volts, since 5 volts is required for the voltage drop across R1 at 20mA. (See Note 2 below).
- D.3.4 If R1 is 250 ohms or more the SMART communicator can be connected between B1-B2, or C1-C2, or D1-D2 or E1-E2. It is also allowable to connect across the SMART Load resistor R1, on B1-A1, or across any resistance in the circuit that exceeds 250 ohms.
- D.3.5 The current loop load resistance R2 can be considered to be part of the 250 ohms needed as the SMART Load resistor. In this case $R1 + R2$ must exceed 250 ohms, and the communicator can be connected between C1-C2, D1-D2, E1-E2, or C1-A1.

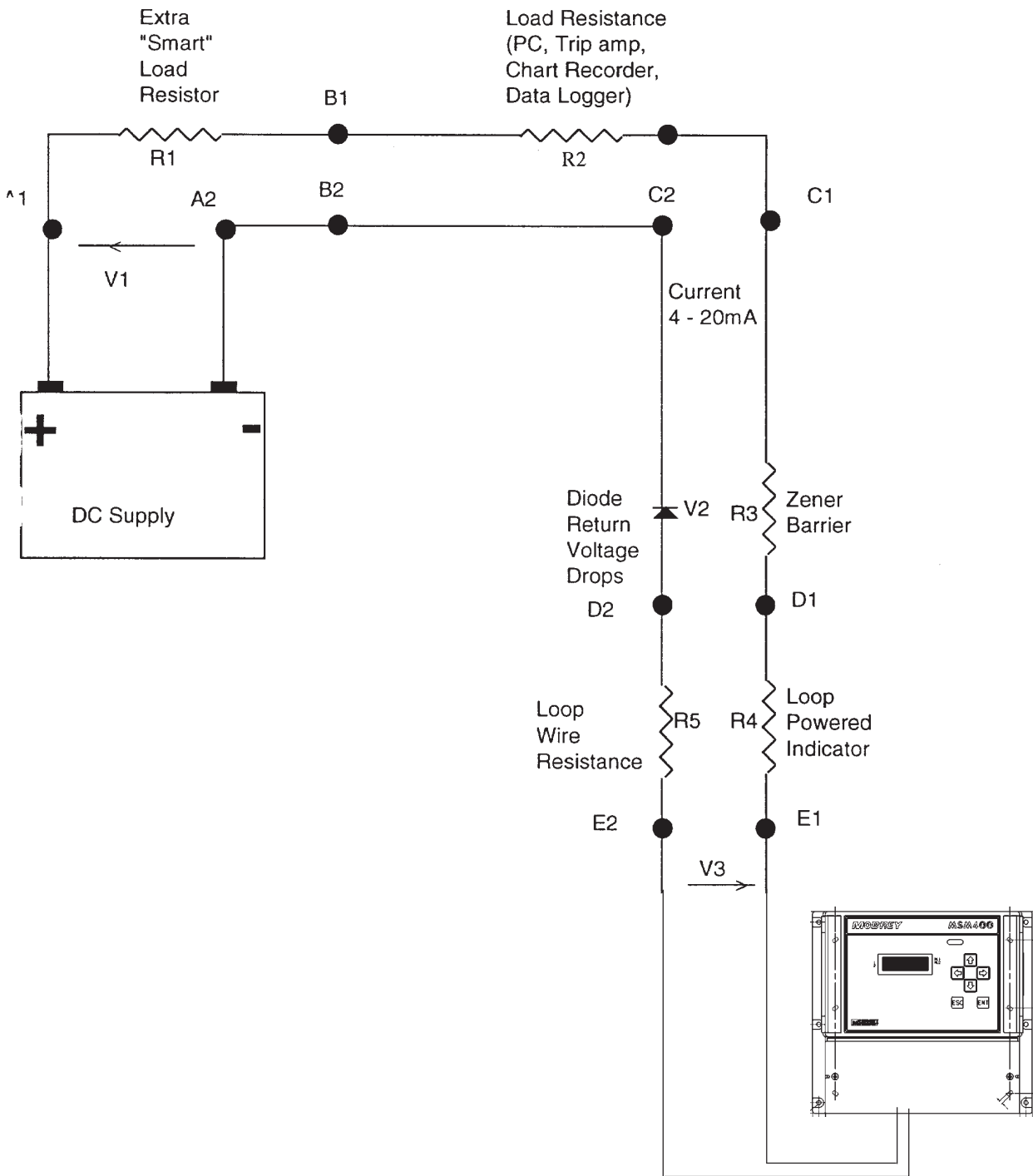

Fig DII. : Loop diagram

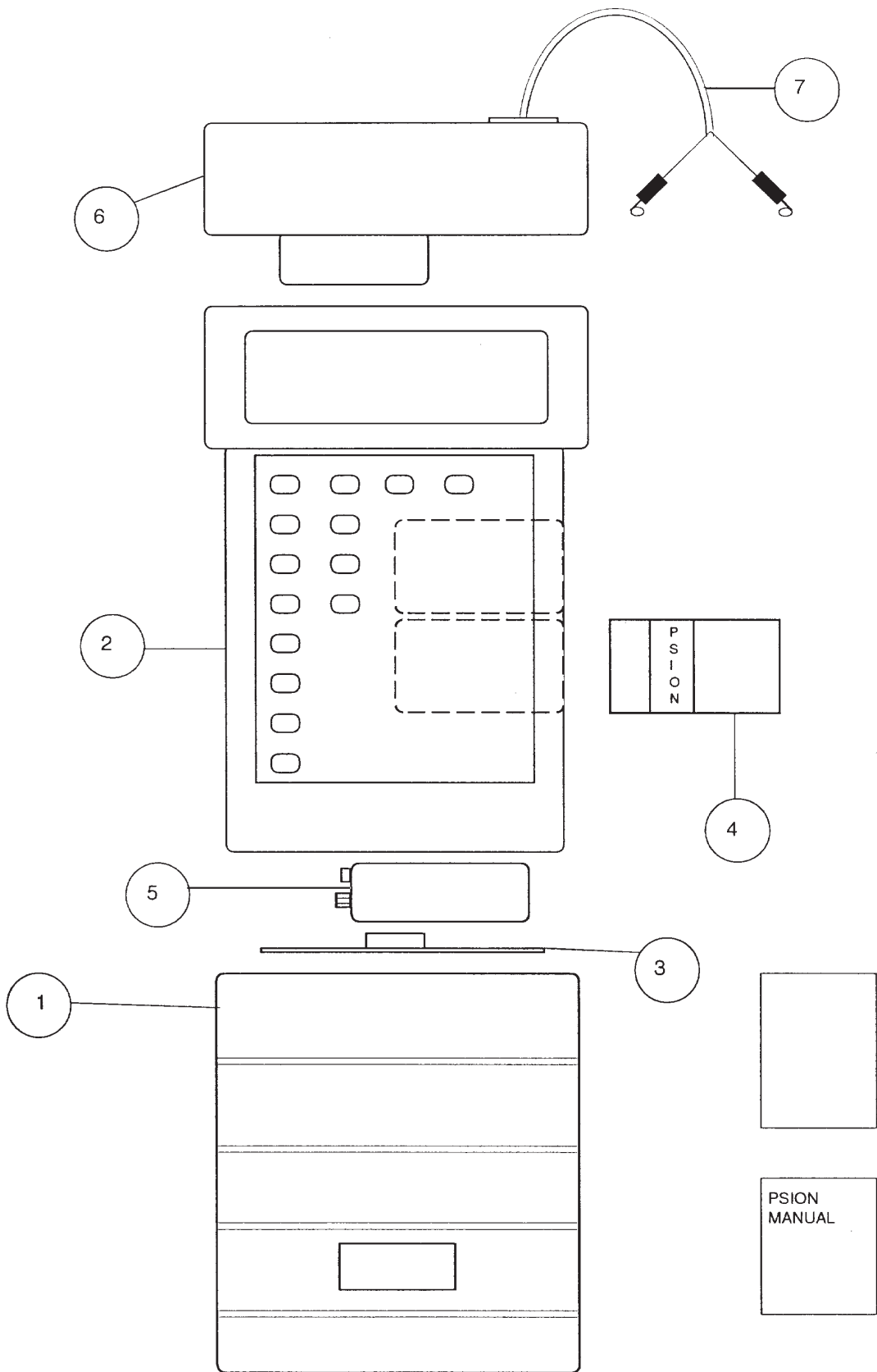

Fig D1 : MOBREY-CK* HHC assembly

Technical Notes:

1. At no time can the SMART communicator be attached across A1-A2, since the DC supply effectively short circuits the transmitted and returned digital communications signals.
2. The minimum DC Voltage V1 required for satisfactory 20mA loop operation can be calculated from the formula –

$$V1 > 2.5 + V2 + [20 \times 10^{-3}] \times (R1 + R2 + R4 + R5)$$

- D.3.6.3. An alternative way of looking at this voltage requirement is in terms of the maximum loop resistance that can be tolerated, which has to be less than $(V1 - 2.5) \times 50$ ohms.

The maximum allowable value for V1 is 30 Volts.

- D.3.6.4. The HART protocol itself sets the maximum values that can apply to the loop resistances, labelled R1 to R5.

The total load on the loop $(R1 + R2 + R4)$ must not exceed 1100 ohms.

In addition the maximum length of cable in a loop working on the HART protocol is specified as 3000 metres on a single screened loop cable, or 1500 metres if multicore multi-loop cabling is used.

D.4.0. How to connect the SMART Communicator

Assemble the Psion based SMART Communicator unit as shown in Fig. D1 fitting the battery, 100 SMART Datapak, SMART Interface unit and lead. The push on crocodile clips are optional.

Power the MSM400 Control unit from a DC supply as shown in Figure D11. A 250 ohm (or higher value) load resistance must be incorporated in the loop.

The SMART Communicator is self powered and draws no current from the loop.

The two wires from the SMART Communicator are interchangeable – it does not matter which way round they are connected.

- a) These two wires can be connected to the HART test pins inside the lid of the MSM400 control unit, using the crocodile clips provided on the CK1 or CK3.
- b) Alternatively connection can be made via the crocodile clips or hook on probes to each wire of the 2 wire current loop at a convenient terminal box or strip.
- c) At the control room the two wires can be connected either across the “SMART” Load resistor or between a terminal on the chart recorder/indicator and the other side of the loop.

D.5.0. Hand Held Communicator : Operation

Language

Initially the Psion Organiser will power up and display the Psion Copyright message, when the ON button is pressed. Then a choice of languages will be offered. This applies to the operation of the Psion Organiser functions only, MSM400 programme, although Datapaks will be available from MOBREY in different languages.

MSM400 Programme

The main menu selection of the Psion Organiser is automatically amended to include the MOBREY option when the Datapak is fitted. This cannot be permanently repositioned nor deleted.

Time

The only data in the Psion Organiser used by the MOBREY programme is the date held in the Organiser memory. On making changes to an MSM400 the date will be stored in the MSM400 control unit microprocessor, as shown by the Psion Organiser. To set this clock, select TIME, press MODE, select SET, and use the arrows to select the correct date and time on the display. Then press EXE to start the clock, and ON/CLEAR to return to the main menu.

Disconnecting SMART Interface

To disconnect the interface unit it is necessary to press down the catch in the top centre face of the unit to release the lock, when the interface can be pulled vertically away. The Psion programme knows when the interface is not present and will no longer seek to find an instrument connected – it will only allow OFFLINE programming. Naturally, no diagnostic parameters are made available.

Note : Programme Lock-up

This will occur if the interface unit is disconnected from the Psion before it has finished all communications, or as a function of the Psion ON button features. The LCD is frozen:

- a) Reconnect the interface unit, to allow completion of the procedure.
- b) If the Lock-up has occurred after pressing the ON/CLEAR button, it probably results from the Psion Organiser "CLEAR" function which stops/freezes all programmes running at the time. The programme can be restarted by pressing any button again (except Q).
- c) If the Lock-up occurs as a result of an incomplete procedure, there is no easy release process. The LCD on the SMART Communicator is frozen. Once the buffer store for instructions has been filled with 16 command key instructions, a bell like sound is made when any further button is pressed. The best escape route is to remove the battery to totally clear the memory of the Psion. Beware that this will also clear the date, diary and alarm memories of the Psion Organiser itself. Clearing the memory occurs after approx. 30 seconds with no battery, or immediately on pressing ON/CLEAR after the battery has been removed.

D.6.0 How to drive a Psion based SMART Communicator

Familiarity with the Psion

The Psion is supplied with several manuals to describe its function. The main keyboard functions that are important are the yellow keys. Press "ON" and see the functions of the arrows to move the cursor around the selections in the menu. Press "EXE" to see the Psion functions. Note that a short cut to selecting a menu item is to press the key with the initial letter of the required selection – for example "O" switches the unit "OFF".

Note that if the "CALC" option is selected, the keyboard changes from the "Alphabet" marked on the keys, to the "numbers" and symbols marked above the keys. The Psion selects the expected function required of the keyboard. This function can be changed back by depressing the "SHIFT" key.

MOBREY Menu

If "MOBREY" is selected from the start up menu on the Psion, by pressing "EXE" the space available in the A memory of the Psion is checked. If there is insufficient then a message is displayed and the program returns to the main menu. Data, Note Pad or Diary files in A must be removed to allow the program to run. The SMART Communicator then establishes whether the SMART interface unit is plugged in or not.

		10:41
MOBREY	Find	Save
Diary	Calc	Time
Notes	World	Alarm

When the SMART interface is not connected, the Communicator does not look for an instrument – it offers OFF-LINE programming.

When the SMART interface is connected to the Psion, on selecting the "MOBREY" menu item the programme seeks an instrument that is expected to be functioning on a 4-20mA loop (the loop that is expected to be connected to the SMART interface cables).

MOBREY V3.1 SEEKING INSTRUMENT PLEASE WAIT
--

If the loop is not powered, or the interface cables are not properly connected to the loop, or the loop impedance/resistance values are incorrect, the unit will fail to find the control unit.

NO SINGLE LOOP INSTRUMENT CONNECTED RETRY (Y)es or (N)o

Note that if the MSM400 control unit is programmed to respond as a numbered sensor on a multidrop loop, it will also fail to communicate to the SMART communicator at this point.

When an MSM400 Control unit is located on the loop, this is identified and further instructions awaited.

```
MSM400          FOUND
TAG      TANK 1
ACCESS (Y)es or (N)o
```

Alternatively an Unknown Instrument may have been found, i.e. a HART instrument that is not a MSM400 or MSP100 or MLT100. This will cause a similar message and prompt to be displayed.

```
UNKNOWN INSTRUMENT
TAG FLOW1
ACCESS (Y)es or (N)o
```

In either case pressing “Y” will cause the following prompt to be displayed:

```
UPLOAD ALL
PARAMETERS
NOW?
(Y)es or (N)o
```

Pressing “Y” will result in all the parameters being read into the HHC. If “N” is pressed then the delay imposed by a full upload can be avoided. If parameters in the D240 to D265 and P100 to P104 are accessed later on all the parameters in that group will be uploaded. Thus only the parameters of interest need to be uploaded, with the minimum delay. A full upload must be done at some stage if the parameters in the instrument are saved, printed, or used to program another instrument.

The asterisks show each transfer of digital information. If one transfer is incorrect, or corrupted, the Communicator will advise and ask for an action decision – an example of one of these error messages is –

```
NO RESPONSE FROM
CONTROL UNIT
RETRY (Y)es or (N)o
```

A retry will attempt to obtain the same data again, whereas the “No” decision will jump that data transfer and collect the next set of data, to try to gain whatever information is available. The data loaded in the Working register for the missing parameters will be the default values, instead of those present in the instrument. Typically, a full upload data collection time is between 30 and 45 seconds.

The main screen describing the equipment now gives control unit identify information – i.e.

```
MSM400
TAG TANK ALL
MSM400 XDUCER
ACCEPT (Y)es or (N)o
```

Line 2 of the display is the Tag number loaded as Parameter 01, and Line 3 is the Description loaded into P700. If this is not acceptable the program suggests a return to the Psion menu functions. If it is acceptable, pressing the Y button will give access to the FUNCTION menu of the MSM400 Program. The MSM400 control unit parameters are now loaded into the SMART Communicator (Psion Organiser) memory in the WORKING Register.

Future work on this data can be carried out whilst the SMART communicator is connected to the loop, in which case all changes will be immediately sent to the MSM400, or after disconnection of the Communicator, in which case the amended programme will have to be stored in the “OFFLINE” register of the communicator.

The Psion Organiser has four separate registers of data relating to the MSM400 control unit. These registers are named WORKING, SAFE, OFF-LINE and DEFAULT, and are explained in Section D13.0. All changes and operations occur in the Working Register, identified by W on the right hand end of line 2 on the display. The other registers are for storage and transfer of data between transmitters or for reference.

D7.0 Introduction and FUNCTION menu

The microprocessor in the MSM400 control unit retains the calibration required for the particular application or tank involved, once this has been entered into the memory (EEPROM). On the initial interrogation of the control unit, this information is transferred to the SMART Communicator using the HART protocol, which defines the command structure and message format.

When received by the SMART Communicator, these messages are loaded into the WORKING register (which resides in the Psion Organiser memory), which then adds the descriptions and other information shown on the 4 line liquid crystal display. The operator is presented with the information he requested, in a meaningful format in relation to the application.

The first selections of the MSM400 control unit programme use a menu structure, where the operator identifies the part of the programme required from a list of options available. The detailed information under each menu item can be inspected, after selection, by scrolling through the listing. Each item is given an identifier in the top right hand corner of the screen, identified by a parameter reference number, to allow accurate recording of the data interrogated and to simplify communications relating to this data.

The programme is divided into two main sets of data, selected from the FUNCTION menu. The FUNCTION menu is the first programme screen presented when the data from the control unit is accepted and interrogation is to begin.

```
***** FUNCTION *****
Calibration
Monitor Program
Info Toggle access
Help D**
```

MONITOR – The data presented on selecting MONITOR is the live “read only” information from the control unit, for example the liquid level in the tank, and the value of the current output. These parameters are labelled D, for Display information parameters, and are indexed between D200 and D265. The Display parameters are described and listed in Section D10.0

PROGRAM – The data presented on selecting PROGRAM is the operator adjustable data used to configure the control unit for the particular application. These are “read/write” parameters, labelled P for Program parameter, and are indexed from P300 to L104. The Program parameters are described and listed in Section D10.0

FIXED DATA – These are the MOBREY factory preset display parameters, identifying the equipment type, serial number, software information, etc.

BACK UP – This menu item controls the transfer of data between registers or a file available in the Psion Organiser memory: operation is described in Section D13.0.

D** - Allows direct access to a Display parameter by entering the relevant code number.

HELP – The HELP information display screens give some introductory advice on the use of the keys on the Psion Organiser and the Programme structure.

D7.1 Monitor/Display Parameters – D**

Access and programme structure

The Display Parameters (D***) are separated into several blocks according to the type of operator read only information. See menu structure in the main body of the manual.

All the Display parameters can be accessed directly from the FUNCTION menu by selecting the appropriate identification number, e.g. D240.

ENTER PARAMETER No D -

The live data recalled on the displays are updated continuously by the SMART Communicator every 0.5 seconds, and so represents the latest available information from the MSM400 control unit. When monitoring these parameters the Psion Organiser is active and so will not switch itself off (the normal action after 5 minutes without any keyboard input).

Additional messages and codes are displayed in a priority order on the LCD when the Display parameters are in use, to indicate exceptional tank conditions or operational problems.

D7.2 PROGRAM Parameters – P***

Access and Programme Structure

The PROGRAM Parameters are separated into three blocks. These blocks are available for operator access to configure the MSM400 control unit as required for the particular application, or adjust the normal mode of operation of the unit. Access to all the PROGRAM parameters is made via the PROGRAM menu.

The three blocks of PROGRAM parameters are as follows:

MODE – The normal operator adjustments equivalent to desludge setup and current input configuration. Parameters P300 - L102.

ENGINEER – The more technical operator parameters, establishing response time, alarm delay time and HMI (keypad sound). Parameters P400 - P562.

OUTPUT – These allow Relay and current output configure.

These PROGRAM parameters are read/write parameters, so that when a particular parameter is recalled its value can be changed by one of three methods – either entering a new value on the blue numeral key pad, or on the alphabet keys for a text entry parameter, or by scrolling sideways. Each of the parameters uses only one of these methods : sideways scrolling is prompted by the appearance of horizontal arrows on line 3 of the LCD. When the new value is on the display correctly, this is entered using the “EXE” key. The SMART Communicator immediately then transmits the change to the MSM400 control unit. If the value is incorrect or the operator wants to revert to the original value, the CLEAR/ON key will reinstate the existing parameter value on the display, without affecting the MSM400 control unit.

Within the memory of the Psion Organiser there are four separate registers for each of the PROGRAM Parameters. These registers are known as WORKING, SAFE, OFFLINE and DEFAULT, and are further described in Section D13.0. All programme changes are made in the WORKING register, and these are the values sent to the MSM400 Control unit memory. The display can be cycled through the registers by using the MODE key, and the initial letter of the register currently displayed is shown at the right hand end of the second line – the same line as the parameter value. Individual parameters can be moved into the WORKING register from other registers, by pressing the EXE key whilst the required register value is displayed.

WORKING REGISTER

Holds the same value as is currently in the control unit.

SAFE REGISTER

Use as a backup, can only be sent to the same control unit as it was loaded from.

OFF-LINE REGISTER

General purpose register, use to program a control unit offline or transfer data between transmitters of the same type.

DEFAULT REGISTER

The normal ex-factory values.

When a new value is programmed into certain parameters a warning message OUTPUT MAY BE CHANGED is displayed with the option to proceed with or abort this change. This may be of importance where the output, either digital or analogue, is controlling some process, such that a sudden change could cause problems.

D8.0 Keyboard Functions

ON/CLEAR KEY

Aborts data entry if this has been started, else returns to the previous menu.

EXE KEY

When display is read/write parameter, writes the value on line 2 or the list selection on line 3 to the control unit.

↑ AND ↓ ARROW KEYS

Used to step through a parameter block in numerical order.

MODE KEY

Used to access the WORKING, SAFE and OFF-LINE registers and the DEFAULT value while a read/write parameter is being displayed. The selected register is indicated by W, S, O or D on the right hand side of line 2.

← AND → ARROW KEYS

Used to select an item from a list when <> is displayed on the right of line 3.

P*** AND D*** ENTRY

Allows direct access to a parameter via its number. Other parameters in the same group can then be accessed by the ↑ and ↓ arrow keys.

HAND HELD COMMUNICATOR REGISTERS

D9.0 SAFE, WORKING, OFFLINE, DEFAULT, Registers

Introduction to Registers

From the FUNCTION screen, whilst interrogating an MSM400 control unit, there is a selection titled "BACKUP". This allows the data now stored in the WORKING register (i.e. the MSM400 control unit data) to be transferred to a separate secure memory, to either retain it while making changes to the MSM400 control unit (i.e. as a "revert to the original program" insurance data store) or to save it in memory so that it can be copied or consulted back in the office. The registers available are

WORKING REGISTER

This is literally the work sheet where all work is done – all changes made to the parameters on the SMART Communicator keyboard are made to the data in the WORKING Register. While the Communicator is attached across the 4-20mA loop, the WORKING register is exactly the same as the MSM400 control unit memory, so all changes made to the WORKING register are also made to the control unit itself. The MSM400 control unit memory and the WORKING register in the SMART Communicator are identical. If communication between the two units fails, then changes attempted in the WORKING register will be rejected.

Note : The SMART Communicator can be unaware of changes to the MSM400 control unit memory made by (a) a Primary Master (such as Mobrey H-View) also attached to this control unit loop, and (b) the local zero and span on the MSM400.

The data existing in the WORKING register is overwritten (and therefore lost) when new data is loaded from another register, or when the SMART communicator is reconnected to an MSM400 loop, because the start up routine will load this new MSM400 memory into the WORKING register. To save any data that has been entered in an "Off-loop" state (i.e. back in the office) the data must be held in the OFFLINE register (see below).

It is recommended that the data in the WORKING register is transferred OFFLINE before disconnection of the SMART communicator from the loop, if it is likely to be needed for reference back in the office. However, the data in the WORKING register is retained in the Psion memory after this disconnection, and can still be interrogated until overwritten by new data.

SAFE REGISTER

The SAFE Register is literally a register where the current MSM400 calibration data can be stored and kept SAFE, while changes are made on the WORKING register and the SMART Communicator is attached to the loop. If these WORKING register changes then prove ineffective or not required, the SAFE register data can be recalled into the WORKING register (and therefore to the MSM400 control unit) to reset all the MSM400 parameters to their original values – i.e. the values in the control unit when the last "Backup" operation transferring the data to the SAFE register was carried out. The data in the SAFE register can only be loaded into the WORKING REGISTER when the communicator is attached to the same MSM400 control unit that was the source of the data – i.e. the control unit with the same unique identifier (D08). It is not possible to transfer programmes between instruments using the SAFE register.

The SAFE register is retained even when the Communicator is disconnected from the loop, powered down, and then reconnected to another loop, collecting new data in the WORKING register. It is not accessible until the correct control unit loop is interrogated, so that the check on the D08 Unique Identifier has been satisfied.

OFF-LINE REGISTER

This is the register used for transfer of programmes between one unit and the next, or from a programme developed on the SMART Communicator at the office desk, stored OFF-LINE and then down loaded into an MSM400 control unit on the plant later. Such data transfer is achieved by connecting the SMART Communicator across the relevant MSM400 loop, loading the WORKING register with the current MSM400 program (see below) then transferring the OFF-LINE stored data into the WORKING register – this overwrites the previous programme in the MSM400 (both the control unit memory and the WORKING Register).

An obvious precaution in the above procedure after loading the WORKING register with the current MSM400 control unit data, is to transfer this data to the SAFE register in case the OFF-LINE sorted new programme does not give the expected result – if necessary the MSM400 can be restored to its original programme status by transferring the SAFE register data to the WORKING register.

The OFF-LINE register is retained when the communicator is disconnected from the loop or powered down. It is only wiped when a new set of data is transferred to the OFF-LINE register from the WORKING register.

Only one set of parameters can be stored in the OFF-LINE register at once.

DEFAULT REGISTER

This is the register of all the normal ex factory settings for the MSM400 Control unit. It is a useful start or reference point for programming any control unit, since the values set in each parameter are known and only those that need The screens showing the Transfer functions of data between registers provide step by step instruction for achieving such data transfer . There are also facilities for allowing the normal interface between the Psion Organiser and a printer or personal computer to provide output of the MSM400 programme data.

The options presented on the LCD are amended when the SMART Communicator senses that a loop is not present or the Interface unit is not plugged into the Psion. In such cases OFF-LINE operation is offered or selected automatically. After changes to the PROGRAM screens which modify data in the WORKING Register, these changes must be saved in the OFF-LINE Register or to a Data File using the TRANSFER function.

b) Loop transfers

The BACK-UP selection on the main FUNCTION menu allows manipulation of the data held in the various registers. Since all transfers are to or from the WORKING Register, the initial screen

```
SELECT DATA SOURCE
Safe      Off Line
Working   Defaults
File
```

Immediately transfers data to the WORKING Register if SAFE or OFFLINE are selected. If the source is a Data File then a location and a File name are prompted for and the data is transferred to the OFFLINE Register followed by a transfer from OFFLINE to WORKING. This final transfer can be prevented by pressing “N” when asked to accept that the output may be changed. If the data source is the WORKING Register, the screen prompts for a full upload if any parameters have not yet been read then asks for a destination decision.

```
SELECT DATA
DESTINATION
Safe      Off-line
File
```

To know where to place the data. Transfer to a Data File will prompt for a location and a file name. The location is either the internal memory at A or a Data or Rampak in the upper side slot which is B. The filename can be up to 8 characters long. In this case the WORKING Register remains unchanged after the data transfer.

Please note that Parameters in the range P44 to P69 are not transferred to the WORKING Register in any BACK-UP data transfer. These parameters are left as set up by the Service Engineer for that particular control unit.

D.9.1 Printout or PC transfer of MSM400 programme data

When used "Off-Line" the Hand Held Communicator can be instructed to transfer the programme memory into a PC or print a list of the parameters and the values in the working register on a paper printer. This is achieved using the Standard Psion COMMS LINK routines and interfaces.

To send or receive data from a PC the COMMS LINK must be plugged in and connected to the PC port and the CL program must be running on the PC. See the COMMS LINK manual for further details.

The Psion will set itself up for transfer to or from a PC when this option is selected.

The file name is any valid MS DOS file name including path names and extensions. The PSION/HART program restricts the length of the input to 17 characters.

The actual transfer to a PC is a complete list of parameter numbers (P100 and P761), of the memory values in the WORKING register. Certain parameters have numeric codes to identify the option (normally chosen in text, such as LINEAR or HOLD). Do not modify this data while it is in the PC file.

To printout the parameter list the COMMS LINK must first be set up to match the requirements of the attached printer with regards to the Baud Rate, start bits, stop bits and protocol. To test the printer and get the desired settings, use the AUTO function in the SETUP menu, and experiment with the HAND settings, try XON + DTR first.

The printout includes the parameter number, title and value of all the valid parameters in the range P100 and P761. Where necessary the value will be related text instead of the value in the data file, e.g. "HOLD" instead of 2.

D.9.2 Display of Parameter Data

The four different registers relate only to the \Programmed Parameters in the MSM400 memory. When interrogating an MSM400 control unit, a typical parameter display would show:

```
STANDING VALUE  P***
      **** **           W
VALUE OF PV
AT ZERO LEVEL
```

The W shown on the second line right hand end indicates that this displayed value is the value present in the WORKING register. This can be compared with the SAFE, OFFLINE or DEFAULT equivalent values by pressing the "MODE" button, which cycles through these registers. The data displayed is labelled with the initial letter of the register selected. This is useful for comparing transmitters (between W and O) or noting changes on this control unit (Between W and S). A transfer of this single parameter can be made into the WORKING register by pressing "EXE" when the desired alternative register value is shown on the LCD – the display will show the letter changing to W to acknowledge the transfer.

D.10.0 ERROR MESSAGES ON THE HHC

D.10.1 Alarm and Error Messages

Throughout the programming of the MSM400 Control unit using the SMART Communicator, any failure of a communication message or other problem in the SMART interface will be advised with a message on the Liquid Crystal Display. Certain error messages prompt for an operator input or decision, for example, whether the procedure should be repeated. These need simple "Yes" or "No" responses. Other errors, for example, "No response from control unit" when programme parameters are being changed, will produce a reset of the parameter value back to the original value in the WORKING Register.

In the first interrogation of the control unit, each asterisk shown on the LCD represents a message, which can contain up to 10 parameters. In the event of a failure of this communication, the option of a retry or move to the next set of parameters is offered. It is always preferred to use "Retry" to collect a full set of data.

Control unit Status Messages

Further operational alarm/error messages are shown on the LCD when any display parameter is selected. When either Readings or Diagnostic parameters (D200 - D265) are shown, the SMART Communicator is interrogating the MSM400 control unit every 0.5 seconds, and the information returned includes various message signals concerning the current status of the returned echo. These messages are displayed on the LCD line 2 for two seconds when the condition is first detected, instead of the Display parameter value. After this display period the condition message is abbreviated to a two letter code shown on the right hand side of the LCD, as long as the condition persists. These status messages are updated every 10 seconds. Only one status message is displayed at a time, in a priority order, as listed below, to see all the alarms present use P520 - P525.

CURRENT SATURATED (CS)

The echo currently monitored is from a process value outside the pre-programmed 4-20mA range, so the current is either at 4mA or 20mA and is possibly not valid.

TEMPERATURE LIMIT (TL)

This indicates that the process temperature or a combination of the process and ambient temperatures have resulted in the electronics becoming too hot or too cold. Using the HHC, check P523 to see the maximum and minimum temperatures recorded. If the MSM400 electronics has recorded a temperature above 55°C then the electronics may have been permanently damaged. The MSM400 should be returned to Mobrey Measurement or your local agent for repair or replacement.

There are also various microprocessor fault messages which should be shown on the LCD, indicating significant problems with the sensor microprocessor. For all these error conditions reference should be made to the factory, and it will probably be necessary to return the unit for repair. The messages and codes are:

ROM CHECKSUM	RC
EEPROM SIGNATURE	ES
EEPROM CHECKSUM	EC
RAM TEST	RT

When an Unknown instrument is being interrogated, a universal set of error messages is used:

DEVICE MALFUNCTION	DV
PV OUT OF LIMITS	PL
NON PV OUT OF LIMITS	NL
CURRENT SATURATED	CS

D.10.2 Invalid Data Entry

When the Operator tries to enter a command or parameter value which is invalid, the message on the screen will indicate this. Typical messages occur as follows:

“INVALID INPUT” (Rejected by the Psion Organiser)
“INVALID DATA” (Rejected by the MSM400 control unit)
- Parameter value entered is outside the limits allowed for that parameter, or resetting of this parameter is not allowed as per the data entered.

“IN WRITE PROTECT MODE”
- The Password is “Closed” or does not allow access to this parameter.

“INVALID PARAMETER NUMBER”
- Parameter number entered is not known by MSM400.

“PASSWORD NOT OPEN”

- If the Password in the MSM400 control unit memory is set “CLOSED”, then it will not be possible to load data from the SAFE or OFFLINE register. The Password protects the data in the MSM400.

“INVALID ACTION NOT THE SAME INSTRUMENT”

- If an attempt is made to transfer SAFE register data to the WORKING register of an MSM400 control unit which is not the origin of the SAFE register data, this will not be allowed. The message indicates that D731 on the currently connected loop is not the same as the D731 in the SAFE register.

“INSTRUMENT IN MULTIDROP MODE”

- The current output control circuitry in the MSM400 control unit is only active when the MSM400 is operating as a 0-20 or 4-20mA device. In a multidrop configuration the current is set to 4mA, and trimming and current set commands are inoperative.

D.10.3 Communication Errors

Communications between the MSM400 control unit and the SMART interface/Psion organiser are subject to error checking and acknowledgement signals according to the HART protocol. This means that only valid messages are accepted, and if the message is invalid then it will be rejected.

The screen of the LCD will indicate if a message has not been received correctly. This is perhaps most likely to be seen when the Display parameters are being used, since these are updated with a new value in a message every 0.5 seconds. If the message is received incorrectly, the second and third lines of the display will show one of the following messages:

VERTICAL PARITY ERROR IN REPLY
OVERRUN ERROR IN REPLY
FRAMING ERROR IN REPLY
LONGITUDINAL PARITY ERROR IN REPLY
BUFFER OVERFLOW IN REPLY

Which describe the cause of the fault.

There is an identical group of errors in the outgoing message:

VERT PARITY ERROR IN OUTGOING MESSAGE
OVERRUN ERROR IN OUTGOING MESSAGE
FRAMING ERROR IN OUTGOING MESSAGE
LONGDNL PARITY ERROR IN OUTGOING MESSAGE
BUFFER OVERFLOW IN OUTGOING MESSAGE

If this occurs frequently, it is appropriate to check the electrical connections to the instrument loop, the presence of the SMART load resistor and that the SMART Communicator is attached at the correct position in the loop.

The “IN OUTGOING MESSAGE” group of error messages if displayed while accessing the Programme Parameters implies that the message from the SMART Communicator was not received correctly by the MSM400. Therefore the instructions in the message would have been rejected, and the Parameters remain unchanged at their previous value. This previous value will be shown on the LCD screen on the SMART Communicator after the error message, to prompt the operator to repeat the last parameter value amendment. During a Register transfer this message will automatically cause the Communicator to hold transmission, and suggest a retry because of the error.

The “IN REPLY” group of error messages if displayed when programming the instrument, signals a more significant communications failure. This indicates that the acknowledgement of the change instruction sent to the MSM400 was incorrect. It is not known whether the Parameter value in the MSM400 was changed or not. The SMART Communicator assumes that it was not changed, and reverts to the original

OFF-LINE MEMORY TRANSFERS

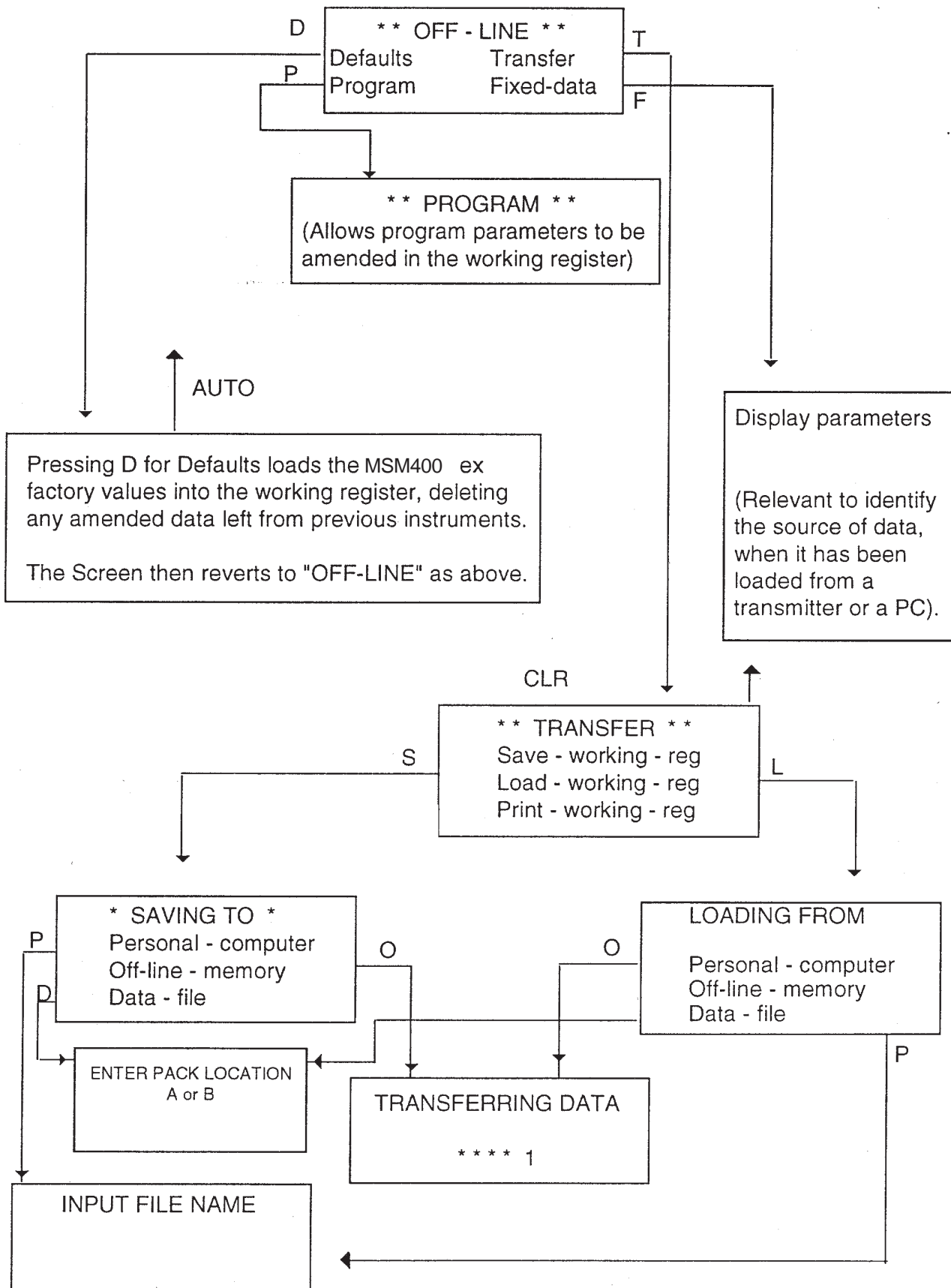

(pre change) value : this prompts the operator to re-enter the required new value. It is important that the Parameter is re-entered, to ensure that the Working register memory in both the Psion and the MSM400 contain the same data.

If either of the above two Outgoing or Reply Comms Error messages occurs in a Backup menu transfer between registers, it is advisable to repeat the Backup operation to complete the data transfer, or check that the memory has been transferred correctly.

The message "NO RESPONSE FROM TRANSMITTER" Indicates a failure of the power on the loop or a failure of the connection of the SMART interface across the loop or the address of the instrument has been changed. Connection should be re-established if possible.

The message "LOCKED OUT BY BUS ACTIVITY" indicates there are either two secondary masters on the bus or a primary master is continuously trying to access an instrument that does not exist.

The message "INCOMPLETE REPLY" indicates that a start of a message was detected but the message was not completed in the time allowed. This is most likely to be due to a power failure or a loss of connection.

D.11.0 Current Loop Checks and Trimming

Introduction

The MSM400 4-20mA control unit has no customer or service engineering adjustable potentiometers on the printed circuit boards. All current trimming of the 4mA and 20mA set points is achieved via the SMART communicator. Because this is a "live" interaction, the access to this function is via the MONITOR functions and screen on the Communicator.

Select "Current – Output" and the screen displayed is

```
** CURRENT OUTPUT **
Set current
Trim-maximum
Trim-maximum
```

These three functions are as follows:

D.11.1 Set current

This selection is used for MSM400 transmitters attached to a single 4-20mA loop to check for correct functioning of all the equipment – the MSM400, the communications and the other loop indicators and outputs.

By selecting the "Set-current" option the screen prompts the operator to choose a current value for the loop, for example 12mA.

```
ENTER NEW VALUE
12-
```

On pressing "EXE", the current in the loop is set to this value, and the loop indicators and trips can be checked for function and calibration. The LCD screen changes to suggest selection of a new value if necessary. To abort the procedure press ON/CLEAR

```
CURRENT OUTPUT =
12 mA
ENTER NEW VALUE
-
```

Some specific error messages are used to prevent the loop current being set outside the valid 4-20mA limits.

D11.2 Trim Current

If the procedure shown above suggests that there is a calibration difference between the MSM400 output and other current monitoring equipment on the loop, it will be necessary to use a calibrated meter to establish which unit is in error. Using the "Set current" routine of the MSM400 can be instructed to provide outputs between 4 and 20mA that the MSM400 considers correct. If these are in error, the "Trim current" routine is used as follows:

The "Trim current" selection sets the current output of the MSM400 either at maximum (supposed to be 20mA) or minimum (supposed to be 4mA) depending on the option selected.

For maximum the display shows:

CURRENT OUTPUT IS
NOW 20mA. MEASURE
CURRENT AND USE ↑ & ↓
TO TRIM THE OUTPUT

Follow the instructions and if the current output is in error, i.e. not 20mA, use the ↑ and ↓ arrows as trimming signals to adjust the value to be exactly 20mA. Each press of the arrow causes an audible signal and adjusts the output value by a discrete step. (approx 6µA)

This process should then be repeated for the 4mA setting. Once the current output is seen to be correct the ON/CLEAR key is used to escape.

Mode Cancelled Warning

If while trimming or fixing the current the analog output returns to its normal mode the message FIXED CURRENT MODE CANCELLED will be displayed. This could occur for three reasons, master has sent the appropriate command, the MSM400 has been powered off then on again, or the output in fixed current mode has been at the same value for 20 minutes.

D.12.0 Unknown Instrument

This limited support for unknown control unit is provided so that the identification and basic performance of any control unit can be obtained without having to change to another HHC. This is of particular use in multi-drop networks where all the currently occupied addresses need to be identified when selecting an address for an additional control unit on the loop.

If the control unit detected is not an MSM400, MSP100 or MLT100 then Unknown instrument is displayed and an access to the parameters is prompted for. If this is selected then the parameters that are present on all transmitters are uploaded, after first setting up any files that are required.

If the instrument conforms to revision 5 or higher of the HART protocol then the manufacturer of the instrument will be available. If it is of an earlier revision then only the model number will be available.

D13.0 SMART Interfaces – Compatibility

D13.1 Introduction

The MOBREY MSM400 SMART slurry monitoring system unit uses the HART digital communications protocol.

This was originally developed by Rosemount Inc. in USA, and uses Bell 202 Frequency Shift Key signalling on top of a 2 wire DC loop supply. The MOBREY MSM400 system conforms to Revision 5.1 of the HART protocol.

Various other manufacturers use this same HART protocol and produce sensor equipment that can be attached to 4-20mA or digital loops. Similarly there are other hand held communicators that use the HART protocol to interrogate transmitters in such loops. Not all manufacturers' equipment conforms to the Revision 5.3 of the protocol.

At present the major SMART communicators working to a HART protocol are

MOBREY –CK1 and –CK2
HART Communicator Model 275 manufactured by Rosemount
Rosemount Model 268
Measurement Technology MTL 611 and CNF 41
MOBREY H-View

This is a rapidly developing field, and the specification of these units is continually being updated. Each updating produces better interoperability and user friendly operation. However, even equipment conforming to the same Revision of the protocol from different manufacturers cannot be regarded as compatible, because each sensor has a unique programme structure.

D.13.2 Transmitters recognised by the MOBREY SMART Communicators

The MOBREY-CK1 and –CK2 SMART Communicators can identify and interrogate all variants of the MLT100 and MSP100 ultrasonic level transmitters and MSM400 slurry monitors.

If a MOBREY SMART Communicator is connected to a loop with another type of control unit, for example the Rosemount 1151 pressure control unit, it will record the presence of an "Unknown instrument". Various parameters can be read and a limited set of common parameters can be changed.

D.13.3 Use of multiple SMART Communicators

The HART SMART protocol allows two SMART digital communicators to be active on the same loop at once. Only one of these can be a hand held communicator (known as "Secondary Master") such as the MOBREY-CK1 or the Rosemount 275 : the second must be a permanent monitoring system such as MOBREY H-View (which is designated as a "Primary Master").

If two hand held communicators are connected to the same loop at the same time and both try to communicate at once there will be a conflict in the messages and neither unit will function correctly.

*The Emerson logo is a trade mark and service mark of Emerson Electric Co.
Rosemount is a registered trademark of Rosemount Inc.
Mobrey is a registered trademark of Mobrey Ltd.
All other marks are the property of their respective owners.
We reserve the right to modify or improve the designs or specifications of product and services at any time without notice.*



© 2004 Mobrey Ltd. All rights reserved.

International:
**Emerson Process Management
Mobrey Ltd.**
158 Edinburgh Avenue,
Slough, Berks, SL1 4UE, UK
T +44 (0) 1753 756600
F +44 (0) 1753 823589
www.mobrey.com

Americas:
**Emerson Process Management
Rosemount Measurement**
8200 Market Boulevard
Chanhassen, MN 55317 USA
Tel (USA) 1 800 999 9307
Tel (International) +1 952 906 8888
Fax +1 952 906 8889

