

PENTAX

COLOR VIDEO CAMERA

MODEL PC-K1100A

INSTRUCTION MANUAL

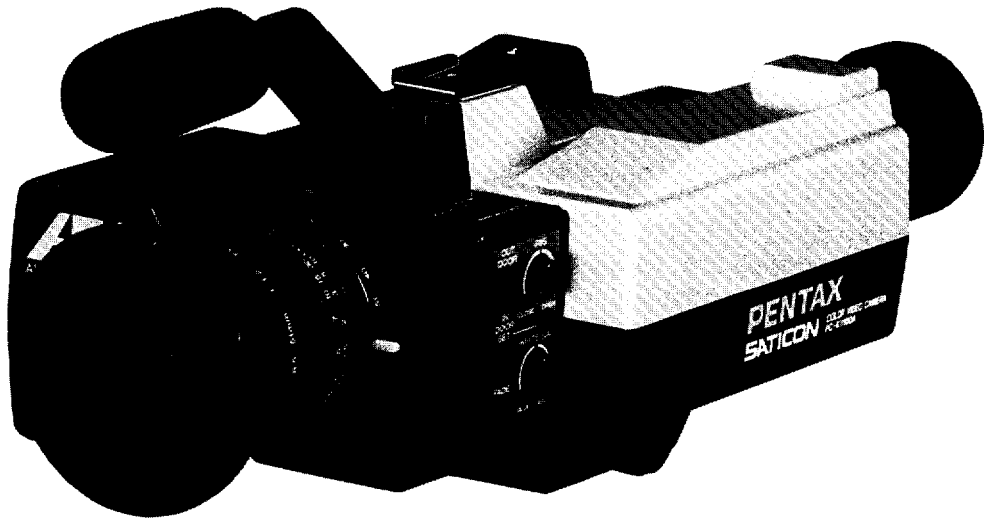



CAUTION

RISK OF ELECTRIC SHOCK
DO NOT OPEN



CAUTION : TO REDUCE THE RISK OF ELECTRIC SHOCK,
DO NOT REMOVE COVER.
NO USER-SERVICEABLE PARTS INSIDE.
REFER SERVICING TO QUALIFIED SERVICE PERSONNEL.

Explanation of Graphical Symbols



The lightning flash with arrowhead symbol, within an equilateral triangle, is intended to alert the user to the presence of uninsulated "dangerous voltage" within the product's enclosure that may be of sufficient magnitude to constitute a risk of electric shock to persons.



The exclamation point within an equilateral triangle is intended to alert the user to the presence of important operating and maintenance (servicing) instructions in the literature accompanying the appliance.

Notice To Users

This camera uses a microcomputer. Read carefully following note, in order to prevent interference to radio and television reception.

This equipment generates and uses radio frequency energy and if not installed and used properly, that is, in strict accordance with the manufacturer's instructions, may cause interference to radio and television reception. It has been type tested and found to comply with the limits for a Class B computing device in accordance with the specifications in Subpart J of Part 15 of FCC Rules, which are designed to provide reasonable protection against such interference in a residential installation. However, there is no guarantee that interference will not occur in a particular installation. If this equipment does cause interference to radio or television reception, which can be determined by turning the equipment off and on, the user is encouraged to try to correct the interference by one or more of the following measures:

- reorient the receiving antenna of receiver
- relocate the camera with respect to the receiver
- move the camera away from the receiver
- plug the AC adaptor into a different outlet so that camera and receiver are on different branch circuits.

If necessary, the user should consult the dealer or an experienced radio/television technician for additional suggestions. The user may find the following booklet prepared by the Federal Communications Commission helpful: "How to Identify and Resolve Radio-TV Interference Problems." This booklet is available from the US Government Printing Office, Washington, D.C., 20402, Stock No. 004-000-00345-4.

**WARNING: TO REDUCE THE RISK OF FIRE OR
ELECTRIC SHOCK, DO NOT EXPOSE THIS
APPLIANCE TO RAIN OR MOISTURE.**

CONTENTS

1.	Features	2
2.	Precautions	2
3.	Description of the parts	4
4.	Indicators inside the electronic viewfinder	6
5.	Connection to a VTR	7
	5.1 Connection to a portable VTR	7
	5.2 Connection to a home VTR	8
6.	Basic operation	9
7.	Adjusting the white balance	10
	7.1 To set white balance	10
	7.2 Fine tone adjustment	10
8.	Auto iris mechanism	11
	8.1 Auto iris	11
	8.2 Iris correction	11
	8.3 Iris lock function	12
9.	Auto focusing	13
	9.1 Continuous auto focusing	13
	9.2 Semi-auto focusing (momentary auto focusing)	13
	9.3 Manual focusing	13
	9.4 Objects not suitable for the auto focus mode	14
10.	Zooming	14
	10.1 Power zoom	14
	10.2 Manual zoom	14
	10.3 Macro mechanism	15
11.	How to make fade-in/fade-out operation	16
12.	Standby switch	17
13.	Monitoring of recorded video and audio signals	17
	13.1 Playback monitoring	17
	13.2 Instant review	17
14.	Remote control unit (option)	18
15.	Troubleshooting	19
16.	Specifications	20
17.	Optional accessories	21

Read this operation manual carefully so you will be able to enjoy all the features in your color camera and then keep the manual in a safe place for future reference.

It is recommended to make test shootings before you plan to make recordings of such important events as weddings, etc. Such troubles as non-recording are not subject to compensation.

Note: The model and serial numbers of your Portable Color Camera and Camera Power Adaptor are important for you to keep for your convenience and protection. These numbers appear on the label located on the bottom of the products. Please record these numbers in the space provided below, and retain its manual for future reference.

Model No. _____

Serial No. _____

1. FEATURES

Clear and vivid pictures

The pickup tube, SATICON* which has been used in broadcast color cameras, is adopted for the camera providing clear and vivid pictures free from sticking and noise even under a low lighting condition. In addition, a built-in bias light guarantees a low lag.

Auto focusing

The camera employs auto focusing mechanism, which automatically focuses just by facing the lens toward an object. This mechanism eliminates troublesome focusing.

6X powered zoom lens

A powered zoom mechanism is provided for smooth zooming operations. A macro position is also provided for close-up shots down to about 1 cm away from the lens.

Compact and lightweight

With a 1/2-inch SATICON pickup tube and a 1-inch picture tube, the camera is very compact and weighs only 1.5 kg (3.3 lbs) together with the camera cable.

Auto white balance

White balance is automatically obtained just by depressing the white balance SET button.

Fade in/out

Audio and video signals can be simultaneously fade in or out. These fade-in/out functions offer a variety of operation.

Instant recording-check

When the camera is connected with your portable video cassette recorder, the recorded pictures can be reviewed instantly by depressing the instant REVIEW button.

Remote control PC-RM11A (Option)

The optional remote control unit enables the camera to control the portable VTR in the items of recording, playback, visual search, etc.

Besides, the remote control unit remotely allows the camera to zoom.

Reduced power consumption

Power consumption is reduced to 4.2 watts. Furthermore, the STANDBY switch is provided to save the life of the battery.

2. PRECAUTIONS

To maintain high-degree performance

*** Before first usage. . . .**

It is possible that a normal picture does not appear when the camera has not been used for an extended period of time.

This is due to the property of the pickup tube. To avoid no pictures and greenish pictures, warm up the camera for about 30 minutes, setting the STANDBY/OPERATE switch to "STANDBY" side, with the lens capped.

*** To prevent SATICON from burning**

- Never point the lens at the sun or any other strong light.
- Switch off its power and attach the lens cap when you are not using the camera.
- Do not shoot excessively bright objects such as fluorescent lamp for a long time to prevent the pickup tube from damage.

* SATICON (Trade Mark)

- * **Avoid high and low temperature and high levels of humidity**
 - Avoid using the camera in locations exposed to temperature of over 40°C (104°F) and under -10°C (14°F) and also to high levels of humidity. This may cause the picture quality to deteriorate or, in serious cases, may cause a failure.
 - A sudden change of atmosphere, such as bringing the camera into heated room after outdoor locations, can cause moisture condensation, and lens may cloud over and the dew will form inside the camera.
- * **Whenever possible, avoid using the camera in locations exposed to strong radio waves or magnetism.**
 - When the camera is used near a radio or TV transmitting antenna or in a location where a strong magnetic field is being generated by a magnet or motor, for instance, stripe interference may appear on the screen or the picture may shake or be bent.

To operate safely

- * Do not open the camera case since a high voltage is generated inside the camera.
- * Do not put inflammable or metal objects inside the camera to avoid failure or accidents.
- * Avoid using the camera where there are gases, and also where there are inflammable and explosive substances in the immediate vicinity.
- * Keep away from water and dust. Also avoid using the camera in the rain or snow. Failure may be caused by water and dust entering the camera.
- * Use the camera power adaptor (option) when connecting to a home VTR.
- * Disconnect the camera cable from the portable VTR or the camera power adaptor and disconnect the power cord from the AC outlet when not in use.

For handling the camera

- * When carrying the camera around, do not subject the camera to heavy shock or vibration.
- * Store the camera in ambient temperature from -30°C (-22°F) to 40°C (104°F).
- * Do not store the camera in high levels of humidity to prevent mold from growing.
- * Clean the lens surface with a soft lens-cleaning cloth or a blower.
- * Clean the eyecup with a dry and soft cloth, because the magnifying lens set in the eyecup is made of plastic.
- * Do not clean the case of the camera with alcohol, benzine, thinners, other volatile substances or with a chemical cloth. These may cause deformation of the case and the paint may be removed. Use a soft cloth for cleaning.
- * Do not wind the power cord, camera cable or VTR cable around the camera itself. Marks may be left if the cord and cables are left like this for a long time.
- * Do not hold the microphone to carry the camera to avoid possible trouble. Do not place the camera upside down to protect the microphone from deformation.
- * Do not point the lens at the sun, since the magnifying lens mounted in the viewfinder employs a convex lens.
If it is left for a long period pointing at the sun, it may cause hazards.

Note:

When pictures being shot by the camera are desired to be monitored on a color video monitor via a camera adaptor, be sure to terminate an input connector of the monitor in 75 ohms. If the monitor is not terminated in 75 ohms, normal picture can not be obtained on the monitor or the electronic viewfinder.

3. DESCRIPTION OF THE PARTS

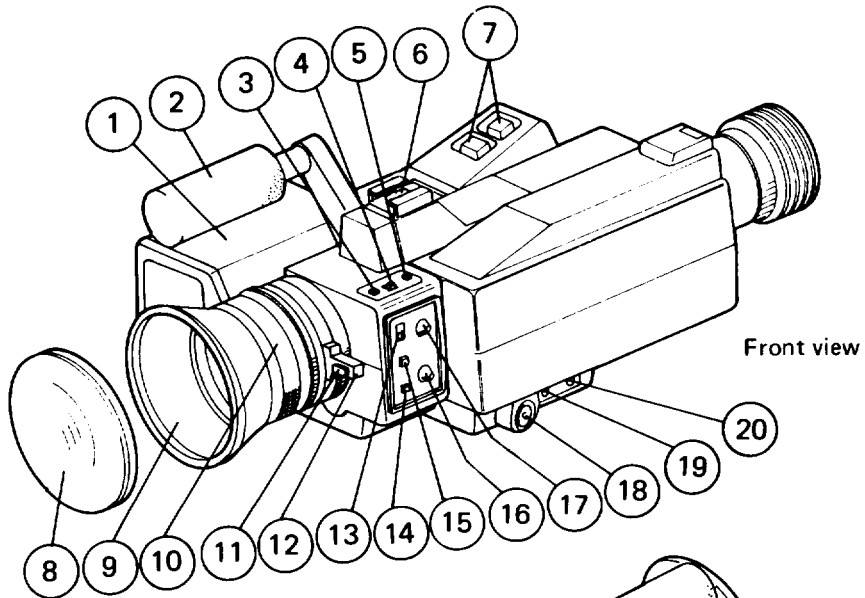

Front view

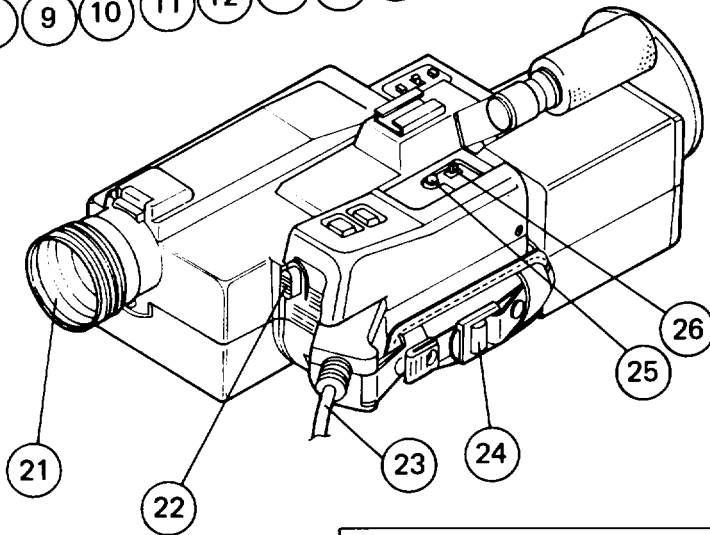

Rear view

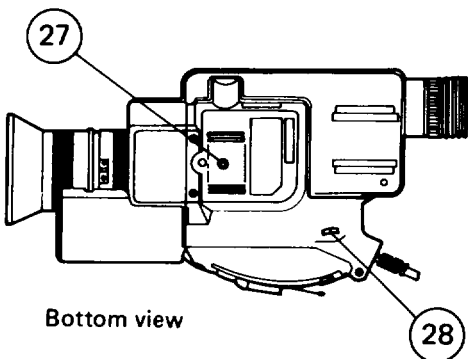

Bottom view

- ① **Auto focus 6x power zoom lens**
- ② **Microphone**
This is the omnidirectional electret condenser microphone.
- ③ **IRIS LOCK button**
Iris is locked only while this button is depressed. Auto iris function activates when this button is released.
- ④ **AUTO/MANUAL focus switch**
Used to select either automatically focusing or manually focusing.
- ⑤ **AUTO focus button**
When the AUTO/MANUAL focus switch is

set to "MANUAL", auto focusing function activates only by depressing this button.

- ⑥ **Accessory shoe**
For mounting your camera light.
- ⑦ **Powered zoom buttons**
W: Wide angle picture is obtained.
T: Telephoto picture is obtained.
- ⑧ **Lens cap**
Attach the cap for protecting the lens while transporting or storing the camera. Recommend to connect the cap with the grip belt by a strap for possible loss.
- ⑨ **Lens hood**
Cuts off residual incident light.
- ⑩ **Focus ring**
For manual focus. The ring rotates automatically in auto-focusing.
- ⑪ **MACRO setting button**
To switch from the wide to the macro mode, depress this button and set the zoom lever to the MACRO side.
- ⑫ **Zoom lever**
Used to manually zoom.
- ⑬ **OUTDOOR/INDOOR switch**
Select this switch according to your shooting condition.
- ⑭ **FADE button**
Pictures fade out while depressing this button. Pictures fade in by releasing the button.
- ⑮ **White balance SET button**
At shooting a white object such as white shirt or white wall, white balance is obtained just by depressing this button.
- ⑯ **WHITE BAL control**
Controls white balance.
Before setting the white balance, set to the center click position.
- ⑰ **IRIS CLOSE/OPEN control**
Controls the lens iris.
Set to the center click position by turning for auto iris operation.
- ⑱ **VTR remote control jack**
Connects with the optional remote control unit PC-RM11A.
- ⑲ **EXT MIC jack**
Connects with an external microphone. While the external microphone is connected, the built-in microphone is cut off.
Note: Use a low-impedance external microphone of -65 dB.
- ⑳ **EAR jack**
Connects with an earphone plug of 3.5 mm in diameter for monitoring the audio signal.
Note: Use a magnetic type earphone of 8 ohms.
- ㉑ **Eyecup**
This can be properly adjusted to your eye. Through the eyecup, you can monitor the shooting pictures on the B/W CRT. Also monitor the playback pictures from your portable VTR.
- ㉒ **VTR start/stop button**
Each depressing this button enables the VTR to start or stop.
- ㉓ **Camera cable**
Connects with the camera power adaptor or the camera connector on your portable VTR.
- ㉔ **Grip belt**
The belt length is adjustable.
- ㉕ **Instant REVIEW button**
Reviews the recorded pictures to instantly check them.
- ㉖ **STANDBY/OPERATE switch**
To reduce power consumption, set it to "STANDBY" side when an interval between shots lasts more than several minutes.
- ㉗ **Tripod screw hole**
Used for mounting a tripod.
- ㉘ **"H/L" selector switch**
To be switched in accordance with VTR to be used with the camera:
at H position . . . for PENTAX VHS portable VTR.
at L position . . . for other VHS portable VTRs. If the "V" indicator inside the viewfinder lights up when the VTR is in the pause mode, turn the switch to "L" position.

4. INDICATORS INSIDE THE ELECTRONIC VIEWFINDER

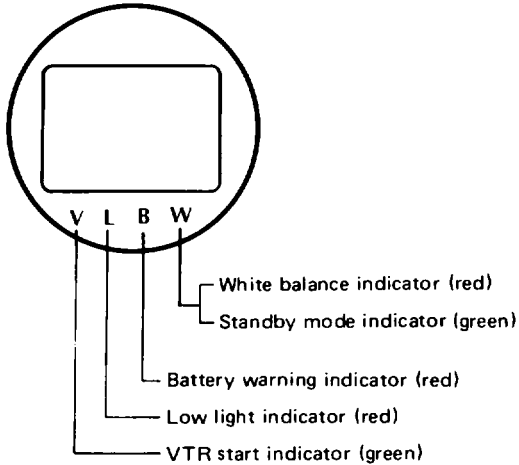

V: VTR start indicator (green)

Lights up when the connected VTR starts recording by the VTR start/stop button on the camera.

L: Low light indicator (red)

Lights up when the object illumination is insufficient. Apply more illumination. Also lights up when the IRIS control is turned counterclockwise.

B: Battery warning indicator (red)

Lights up when the battery voltage supplied from the portable VTR falls below rating. In this case, replace the battery with a new one or recharge the battery.

W: White balance indicator (red)

Standby mode indicator (green)

- * The "W" indicator lights up red when white balance has not been obtained after power on. In this case, shoot a white object so that it appears on the full screen inside the viewfinder. Then, depress the white balance SET button until the red indicator goes off.
- * The "W" indicator lights up green when the STANDBY/OPERATE switch is set to the STANDBY.

Electronic viewfinder

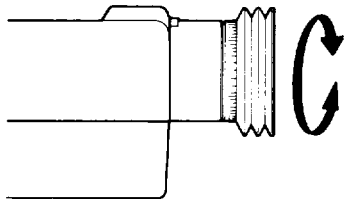

For easy viewing, correct eyepiece by rotating the eyecup fixing ring.

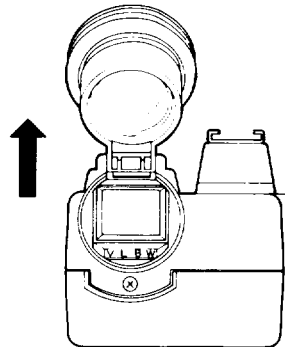

When monitoring the viewfinder at a distance, open the eyecup upwards carefully.

5. CONNECTION TO A VTR

5.1 Connection to a portable VTR

Connect the camera cable of the portable color camera to the camera connector on the portable VTR.

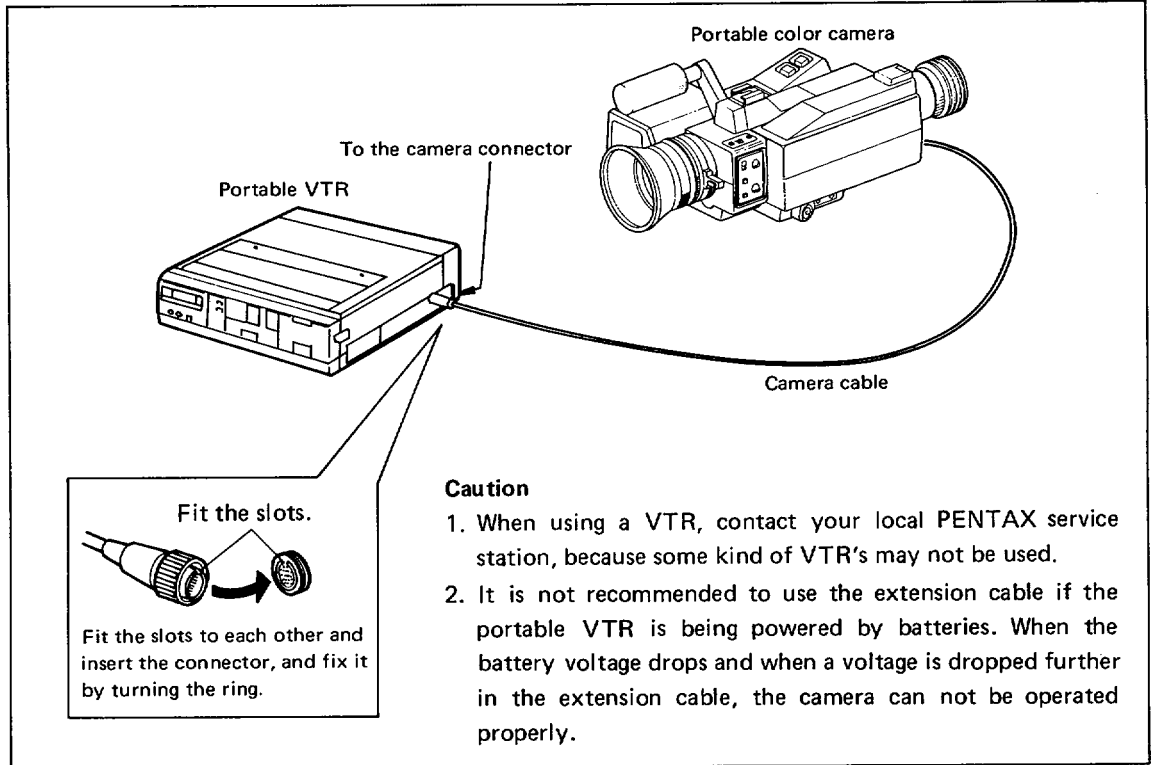

5.2 Connection to a home VTR

The camera power adaptor (option) is available as the camera power source.

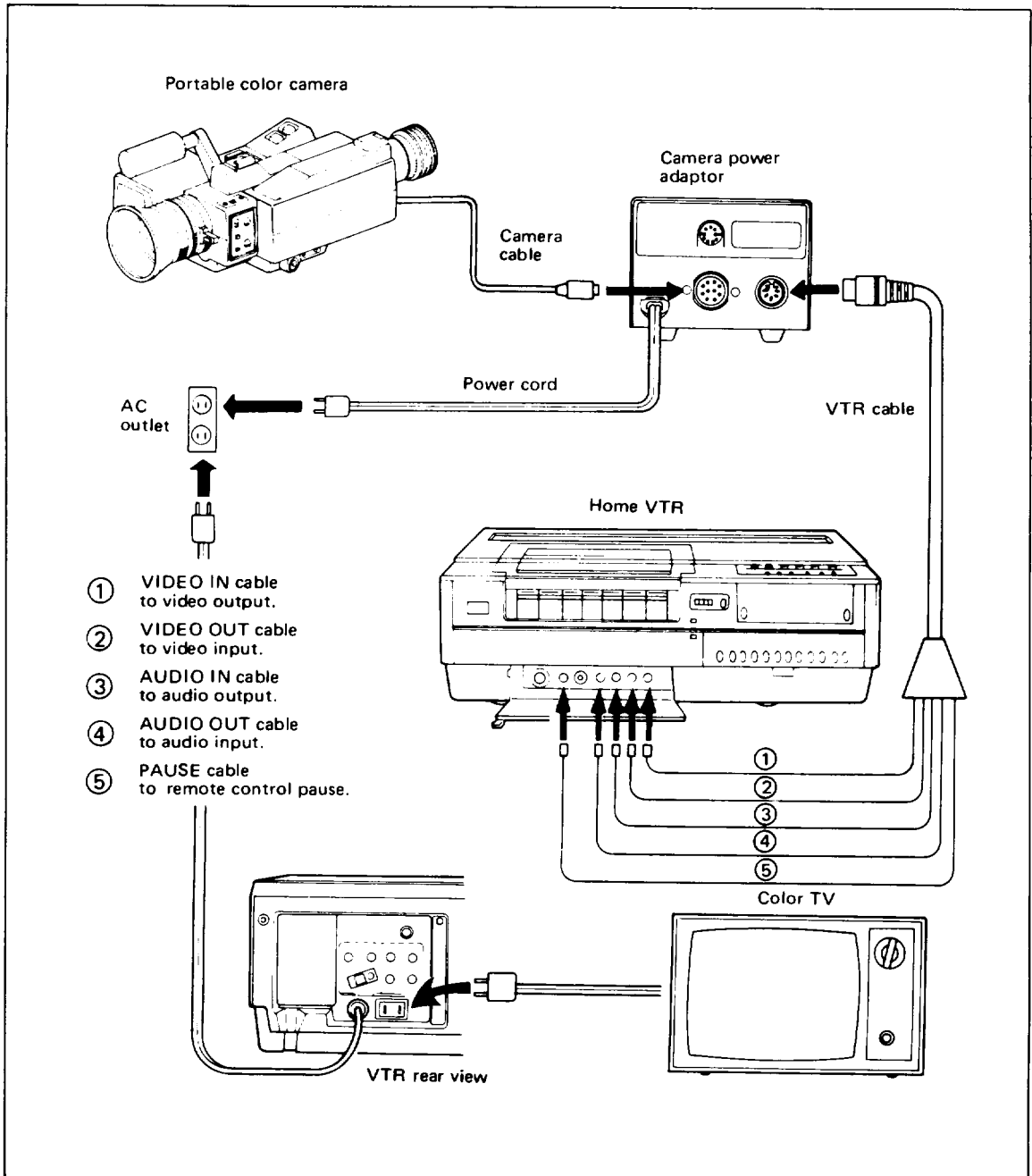

Caution

1. The markings on the VTR cable between the Camera Power Adaptor and the VTR show the camera side in-out functions.
2. When the white VIDEO IN cable is inserted into the video output connector of the connected home VTR, the playback pictures can not be monitored on the viewfinder.
3. When using the camera with the Camera Power Adaptor, the maximum length of the optional camera extension cable should be less than 10 meters. If a longer cable is used, voltage drops in the extension cable can cause the camera not to operate properly.

6. BASIC OPERATION

Experienced operation boosts your recording quality. Before recording, shoot something on trial as shown below.

- (1) Set the switches and controls as shown in the figure.

- 1) Set the IRIS CLOSE/OPEN control to the center click position.
- 2) Select the OUTDOOR/INDOOR switch according to the light source exposed to the object.
- 3) Set the WHITE BAL control to the center click position.
- 4) Set the STANDBY/OPERATE switch to "OPERATE" side.

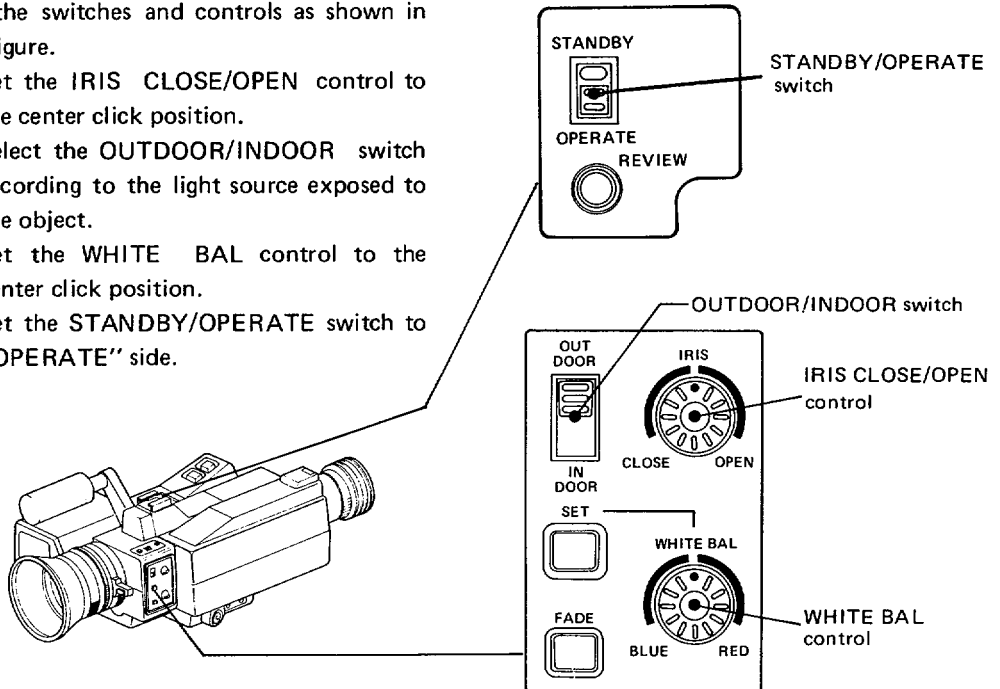

- (2) Turn the VTR power to "ON".
By depressing both the Record and Play buttons on the VTR simultaneously, set the VTR in pause.
- (3) Remove the lens cap.
- (4) Check that all indicators of "V", "L", and "B" excluding white balance (W) indicator go off.
- (5) Shoot a white object, and obtain the white balance by depressing the white balance SET button.
(See page 10.)
- (6) Set the AUTO/MANUAL focus switch to the "AUTO" side.
- (7) Depress the VTR start/stop button. Then the indicator "V" lights up and recording starts.
- (8) Shoot an object by the powered zoom button or the zoom lever.
- (9) Depress again the VTR start/stop button. Then the indicator "V" goes off and recording stops.

Note:

To prevent camera movement which causes blurred images, hold the camera firmly with both hands with the elbows braced against your body.

7. ADJUSTING THE WHITE BALANCE

The human eye tends to adapt itself to the light and a white object may appear to be white both with indoor and outdoor illuminations. However, the camera does not have the same ability to adapt and so, depending on the color temperature of the light source, the white object may appear reddish or bluish. The white balance control is provided in order to compensate for this. This control should be used as a preparatory step to shoot objects in their natural colors.

7.1 To set white balance

- (1) Set both the IRIS CLOSE/OPEN and the WHITE BAL controls to each center click position.
- (2) Select the OUTDOOR/INDOOR switch according to the light source exposing the object.
- (3) Remove the lens cap. Then, check that the low light indicator "L" is not lit up.
- (4) Shoot a white object such as a white wall etc. and allow it to appear on the full screen of the viewfinder.
- (5) Depress the white balance SET button until the indicator "W" inside the viewfinder goes off. (It will take about three seconds for completing the white balance setting.)

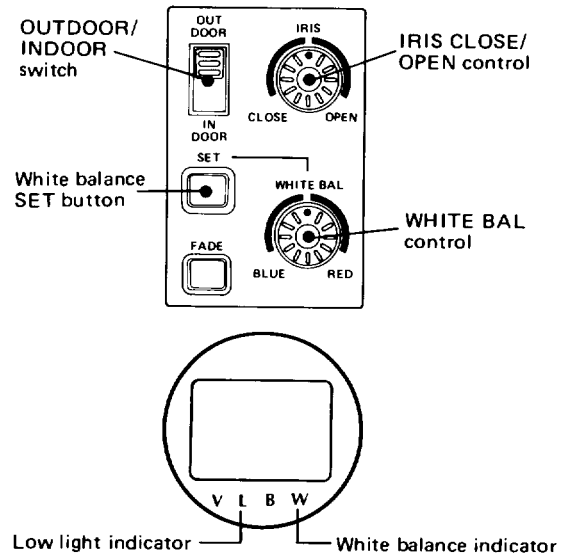

Notes:

1. The white balance cannot be adjusted with colored objects. If a white object is not available, avoid shooting an excessively colored objects such as red and blue objects, then set the lens to the wide angle and depress the white balance SET button.
To obtain more accurate white balance, try to shoot a white object.
2. When an object is exposed to both indoor and outdoor light sources, select the OUTDOOR/INDOOR switch according to larger amount of light source.
3. The white balance can not be precisely obtained in the following cases.
 - (1) For about 6 seconds after the camera power is "ON".
 - (2) Insufficient luminance.
 - (3) While a camera or an object is moving.
 - (4) For about 3 seconds after the camera turns to strong light.

Proper color temperatures of light source are listed below. Select the OUTDOOR/INDOOR switch.

Light source	OUTDOOR/INDOOR switch	Color temperature
Tungsten lamp	INDOOR	3,000 to 3,200 K
Fluorescent lamp	INDOOR	4,000 to 5,000 K
Sunny day	OUTDOOR	5,500 K
Cloudy day	OUTDOOR	6,000 to 7,000 K

7.2 Fine tone adjustment

The WHITE BAL control is provided for adjusting the color tone. Monitoring a picture on a color monitor, rotate the control clockwise for reddish pictures and rotate it counterclockwise for bluish pictures.

8. AUTO IRIS MECHANISM

8.1 Auto iris

The camera is provided with an auto iris mechanism which automatically adjusts the lens iris in accordance with the incident light. When the object is dark, the iris opens automatically, and it closes when the object is bright. When the camera's power is switched off, the iris is automatically set to the fully closed position.

In the case of shooting with auto iris, set the IRIS CLOSE/OPEN control to the center click position.

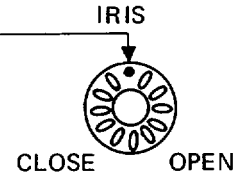

8.2 Iris correction

Iris can be corrected by the IRIS CLOSE/OPEN control in the following cases.

- (1) The object may appear dark when a bright backlight exists. In this case, set the IRIS CLOSE/OPEN control to the opened zone.

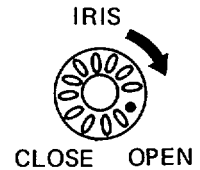
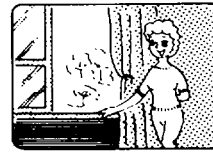
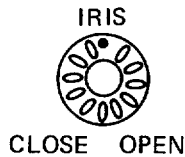
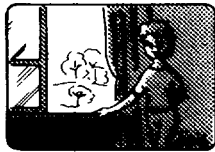

- (2) The object may appear whitish when a dark backlight exists. In this case, set the IRIS CLOSE/OPEN control to the closed zone.

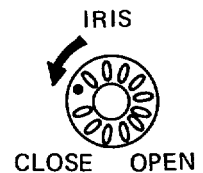
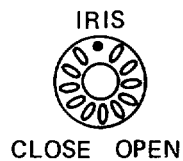

Notes:

1. In backlight condition, carefully shoot an object so that strong light such as sunlight, spotlight, etc. does not enter the lens. Strong light may cause burning on the photosurface of the pickup tube.
2. The low light indicator "L" inside the viewfinder lights up when the object illumination is insufficient although the IRIS CLOSE/OPEN control is set to "OPEN". In this case, increase the illumination.

8.3 IRIS LOCK function

The IRIS LOCK button is provided for locking the iris and maintaining the locked iris.

Since the camera employs auto iris mechanism, the iris is automatically adjusted according to the illumination.

If a scene having extremely bright or extremely dark portions is shot momentarily, the shooting pictures brightness will change. To prevent this change, lock the iris by depressing the IRIS LOCK button. After releasing the IRIS lock button, the auto iris refunctions.

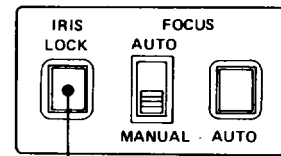

IRIS LOCK button

The brightness of the object should be optimum to obtain a beautiful color picture. The table below shows the approximate values of brightness. Set the optimum brightness of the object referring to the table below. It is recommended to add more illumination if the brightness is less than 500 lux, to obtain a beautiful picture.

Brightness approximations

Unit : lux

10	—	○ Candle at 20 cm (10-15 lux)
		○ Cigarette lighter at 30 cm (15 lux)
		○ During intermission at movie theater (15-35 lux)
100	—	○ Workshop in machinery factory (150-200 lux)
		○ Arcade at night (150-200 lux)
		○ Flashlight at 1 meter (250 lux)
		○ Study desk with fluorescent lighting (400 lux)
		○ Office with fluorescent lighting (400-500 lux)
		○ Library reading room (400-500 lux)
		○ Bowling alley (500 lux)
		○ Sales floor of department store (500-700 lux)
1,000	—	○ Clear day one hour before sunset (1,000 lux)
		○ Cloudy day one hour after sunrise (2,000 lux)
10,000	—	○ Cloudy day at 10 AM (25,000 lux)
		○ Cloudy day at noon (32,000 lux)
		○ Clear day at 3 PM (35,000 lux)
		○ Clear day at 10 AM (65,000 lux)
100,000	—	○ Clear day at noon (100,000 lux)

* The above table gives approximations only. Use the figures as a guideline.

9. AUTO FOCUSING

The camera is provided with an auto focusing mechanism which automatically adjusts the distance from rangefinder window on the camera to an object and focuses by automatically rotating the focus ring.

9.1 Continuous auto focusing

For continuous auto focusing, set the AUTO/MANUAL focus switch to the "AUTO" side.

9.2 Semi-auto focusing (momentary auto focusing)

For momentary auto focusing, set the AUTO/MANUAL focus switch to the "MANUAL" side, then depress the AUTO focus button. Auto focusing activates while the button is depressed.

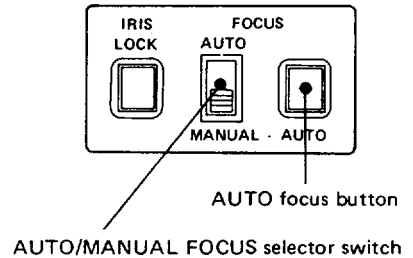

Notes:

1. During the auto focusing mode, do not touch the focus ring. This may cause malfunction. Also, do not screen the rangefinder window.
2. Set the AUTO/MANUAL focus switch to "MANUAL" side while not shooting.
3. Allow the object to be focused at the center of the viewfinder screen.

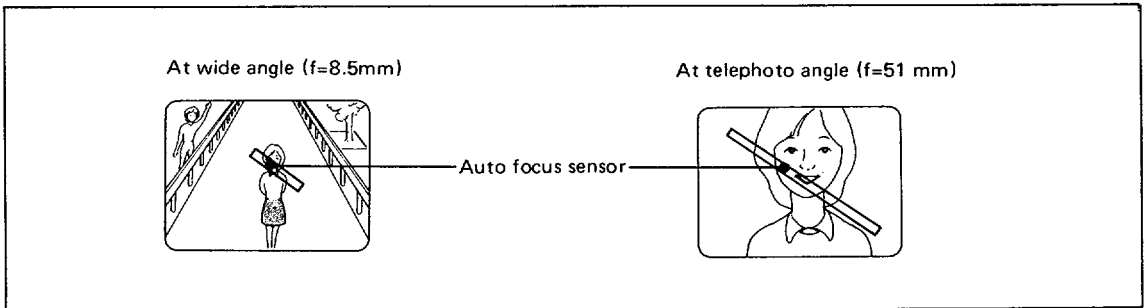



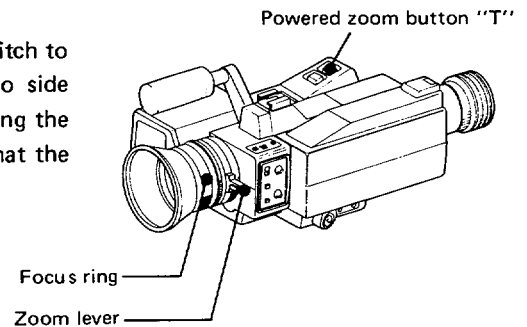

9.3 Manual focusing

For manual focusing, set the AUTO/MANUAL focus switch to the "MANUAL" side. Set the lens to the telephoto side by depressing the powered zoom button (T) or rotating the zoom lever. Then, rotate the focus ring manually so that the object is focused.

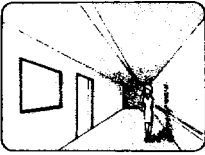

9.4 Objects not suitable for the auto focus mode

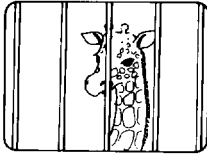
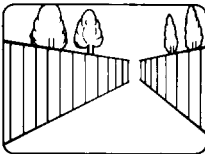
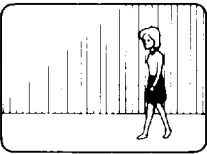
In the case of shooting the following objects, the auto focus may not function properly. In such cases, perform focusing manually, by setting the AUTO/MANUAL focus switch to the "MANUAL" side.

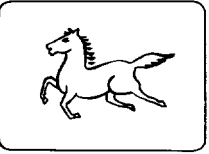
<p>① Object is dark. (less than approx. 10 lux)</p>	<p>② Object with less contrast.</p>	<p>③ Object with bars or net in foreground.</p>	<p>④ Continuation of similar objects in the distance, such as fence bars.</p>
			
<p>⑤ Objects with an equally divided pattern.</p>	<p>⑥ Object with high reflection.</p>	<p>⑦ Fast moving objects.</p>	
			

10. ZOOMING

The camera is provided with a power zoom mechanism for easy and smooth zooming operation.

10.1 Power zoom

Depress the powered zoom button "T" or "W". Allow about 7 seconds to zoom from wide to telephoto.

10.2 Manual zoom

Zooming can be also done manually with the zoom lever.

Powered zoom button "W" Powered zoom button "T"

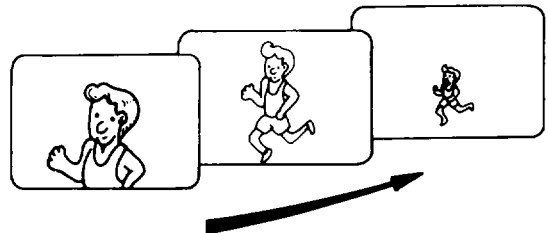
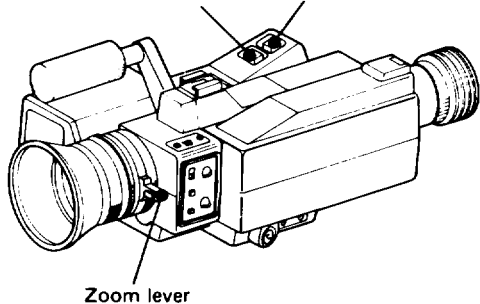

By depressing the "W" side, the field of view gradually becomes wider.

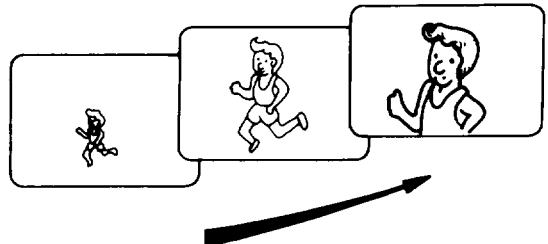

By depressing the "T" side, the field of view gradually becomes narrower.

Note:

During the power zoom operation, do not touch the zoom ring. This may cause malfunction.

10.3 Macro mechanism

This camera is provided with a macro mechanism and it is possible to shoot an object as close as 1 cm from the lens.

- (1) Remove the lens hood before macro mechanism operation.
- (2) Set the AUTO/MANUAL focus switch to the "MANUAL" side.
- (3) By rotating the zoom lever, with the green MACRO button depressed, set the zoom lever to the "MACRO" position.
- (4) Set the angle according to the distance between the camera and the object.
- (5) Zoom within the "MACRO" range, and focus.

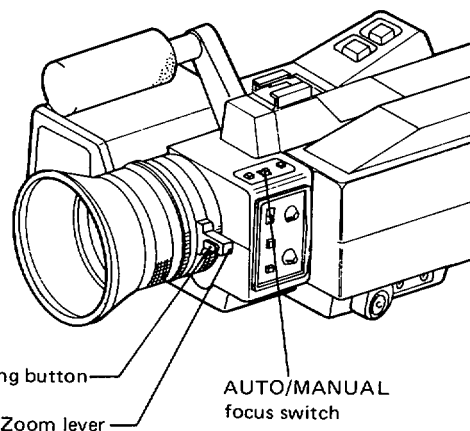

Note:

When the object is very close to the lens, make sure that the illumination is adequate or even.

11. HOW TO MAKE FADE-IN/FADE-OUT OPERATION

Fade-in and fade-out are shooting techniques to soften the transition of the scenes from one to another. In the fade-in mode, a picture and sound will gradually appear. In the fade-out mode, a picture and sound will gradually disappear.

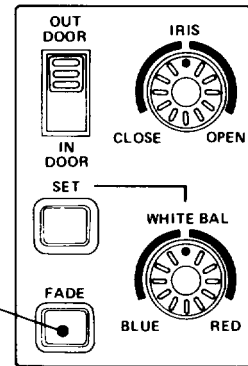

FADE-IN

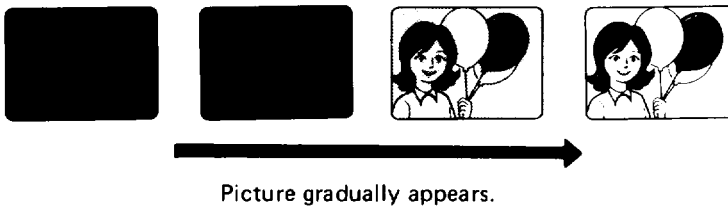

- (1) Establish the pause mode in the VTR.
- (2) Keep depressing the FADE button until the picture fades out. The picture will start to fade out 1 second after the button is depressed and disappears in 3 seconds.
- (3) Depress the VTR start/stop button. While depressing the FADE button. Then, the recording starts.
- (4) Release the FADE button, and the picture gradually fades in 4 seconds.

FADE-OUT

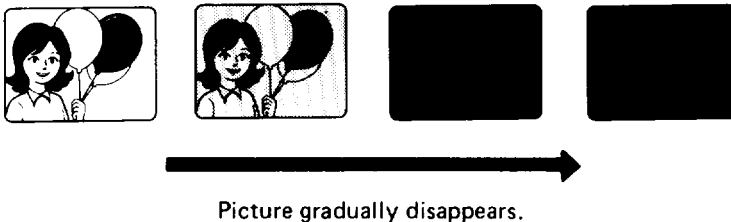

- (1) Keep depressing the FADE button in the Record mode until the picture fades out. The picture will start to fade out 1 second after the button is depressed and disappear in 3 seconds.
- (2) Depress the VTR start/stop button, and the VTR establishes pause mode.
(After releasing the FADE button, the picture gradually reappears on the viewfinder.)

12. STANDBY SWITCH

When the camera is connected to a portable VTR and power is being supplied from the battery inside the VTR, power is consumed even in the pause mode just as in the camera record mode. This camera is equipped with a STANDBY/OPERATE switch to prevent excess drain of the battery power.

Set the switch to the "STANDBY" position when an interval between shots last more than several minutes, and this will reduce the power consumption to 20%.

Set the switch to the "OPERATE" position a little before resuming recording. Then, depress the VTR start/ stop button to start recording after the picture on the electronic viewfinder has stabilized.

When the STANDBY/OPERATE switch is set to the "STANDBY" position, the picture on the electronic viewfinder disappears and the "W" indicator lights up green.

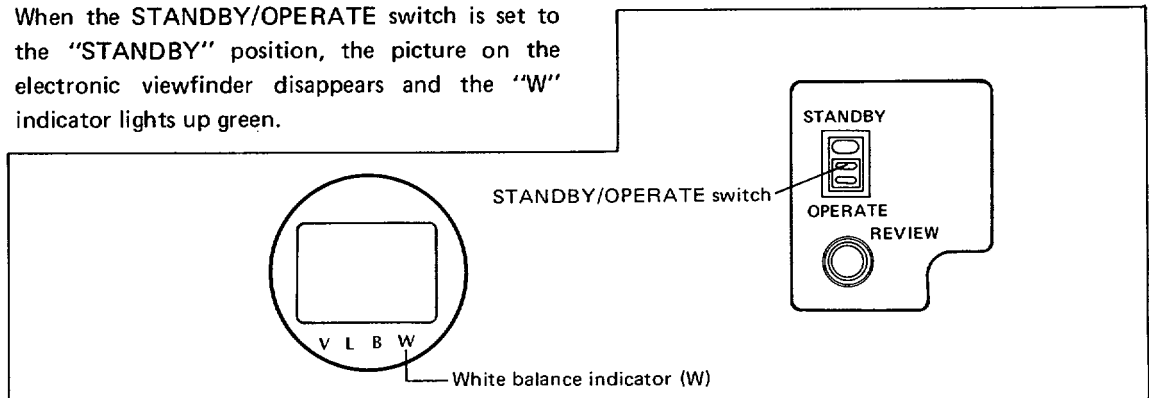

13. MONITORING OF RECORDED VIDEO AND AUDIO SIGNALS

When the camera is connected to a portable VTR, the recorded picture can be monitored on the electronic viewfinder. By using an earphone, the recorded sound can be monitored. The last shots for a few seconds of the recorded picture can be instantly reviewed by pressing the REVIEW button.

13.1 Playback monitoring

- (1) Connect an earphone to the EAR jack.
- (2) Load the recorded tape on a portable VTR.
- (3) When the VTR is set in the PLAY mode, the playback picture appears on the electronic viewfinder. Sound can also be monitored through the earphone.

Use a magnetic type earphone (8Ω impedance).

13.2 Instant review

- (1) Set the VTR in the pause mode after the recording has been completed.
- (2) Press the REVIEW button. Then the tape is rewound for a few seconds and the recorded picture is played back. The recorded condition is thus checked. The VTR returns to the pause mode when the playback has been completed.

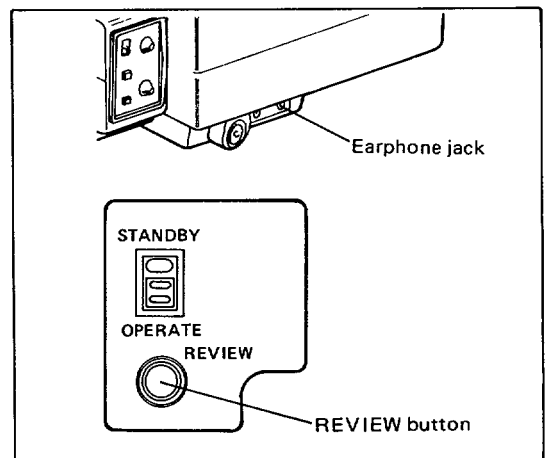

Note: The record check function is not available when the camera is connected to a home VTR or some kind of portable VTRs.

14. REMOTE CONTROL UNIT PC-RM11A (OPTION)

The remote control unit makes it possible to control a VTR while operating the camera. The zooming operation can be done about 7 m away from the camera.

- ① The remote control unit can be installed on the bottom of the camera.

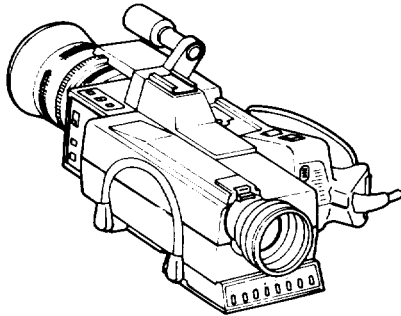

- ② The camera can be remotely controlled.

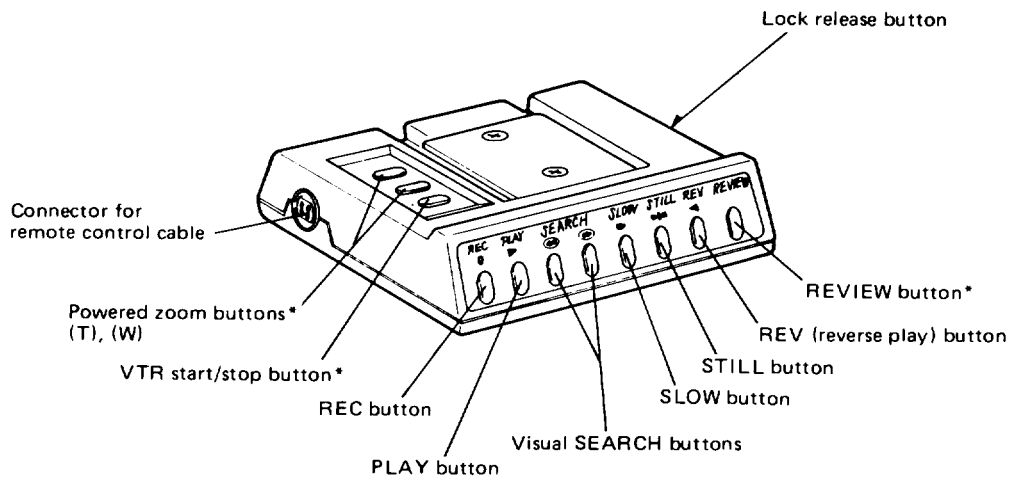
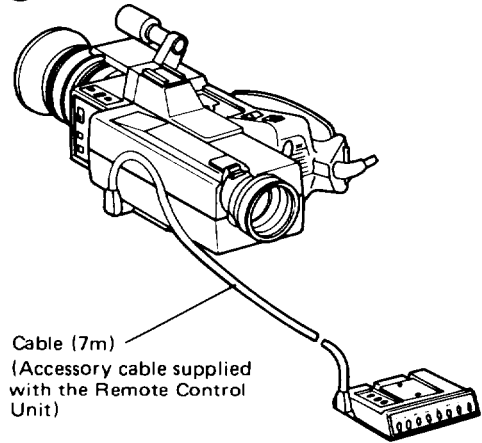

* The powered zoom buttons, the VTR start/stop button and the REVIEW button have the same functions as those of the camera.

15. TROUBLESHOOTING

Before calling your local PENTAX service station, check the followings.

Symptoms	Check points
Electronic viewfinder, no picture on screen	<ul style="list-style-type: none">○ Check if the camera cable is connected to the VTR.○ Check if the power switch of the VTR or the camera power adaptor is "ON".○ Check the battery of the portable VTR.○ Check if the STANDBY/OPERATE switch is at "OPERATE".○ Check if the lens is uncapped.○ Check if the IRIS CLOSE/OPEN control is set to center click.
Reddish or bluish picture	<ul style="list-style-type: none">○ Check the illumination.○ Check if the OUTDOOR/INDOOR switch is set correctly.○ Check if the WHITE BAL control is set correctly.○ Check if the white balance SET button has been depressed.○ Check the color TV set is adjusted properly.
Not auto focusing	<ul style="list-style-type: none">○ Check if the AUTO/MANUAL focus switch is set to "AUTO".○ Check if the rangefinder window is not screened.○ Check if the shooting object is not suitable for auto focusing as shown on the page 14.

16. SPECIFICATIONS

Pickup tube	1/2-inch single frequency separation type SATICON pickup tube
Color system	NTSC
Sync system	Internal
Scanning lines	NTSC : 525 lines 2:1 interlace
Video output	1Vp-p, 75-ohm (unbalanced)
Horizontal resolution	270 lines at center
Video S/N	Better than 45 dB (luminance channel)
Recommended object illumination	500 lux or more
Minimum illumination	10 lux
Automatic sensitivity control	10 to 100,000 lux
Microphone	Omnidirectional electret condenser microphone
External microphone	-65 dB, low impedance
Audio output	-20 dB, load impedance 10 k Ω or more
Lens	f1.2, 8.5-51 mm (6x zoom), auto focus, power zoom, auto/manual iris, with macro function filter diameter of 52 mm
Viewfinder	Electronic viewfinder Picture tube : 1-inch black-and-white
Indicators	VTR start, low light, battery warning, white balance and standby mode
White balance adjustment	Auto white balance setting
Power supply	12V DC
Power consumption	Approx. 4.2W (When auto focus and power zoom are not in operation.)
Dimensions	140(W)x 121(H) x 296(D) mm (5.51 x 4.76 x 11.65 in)
Weight	Approx. 1.5 kg (3.3 lbs) (incl. camera cable)

* The specifications and design are subject to change without notice.

17. OPTIONAL ACCESSORIES

Extension cable 10 m
VK-CK61E

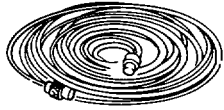

Remote control unit
PC-RM11A

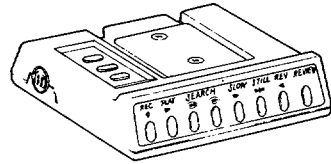

PENTAX

PENTAX CORPORATION 35 Inverness Drive East, Englewood, CO 80112
For service information call 800 321-5245, In Colorado call 773-1101

IMPORTANT SAFEGUARDS

1. Read Instructions

All the safety and operating instructions should be read before the appliance is operated.

2. Retain Instructions

The safety and operating instructions should be retained for future reference.

3. Heed Warnings

All warnings on the appliance and in the operating instructions should be adhered to.

4. Follow Instructions

All operating and use instructions should be followed.

5. Cleaning

Unplug this video product from the power source before cleaning. Do not use liquid cleaners or aerosol cleaners. Use a damp cloth for cleaning.

6. Attachments

Do not use attachments not recommended by the video product manufacturer as they may cause hazards.

7. Water and Moisture

Do not use this video product near water — for example, near a bath tub, wash bowl, kitchen sink, or laundry tub, in a wet basement, or near a swimming pool, and the like.

8. Accessories

Do not place this video product on an unstable cart, stand, tripod, bracket, or table. The video product may fall, causing serious injury to a child or adult, and serious damage to the appliance. Use only with a cart, stand, tripod, bracket, or table recommended by the manufacturer, or sold with the video product. Any mounting of the appliance should follow the manufacturer's instructions, and should use a mounting accessory recommended by the manufacturer.

9. Ventilation

Slots and openings in the cabinet are provided for ventilation and to ensure reliable operation of the video product and to protect it from overheating, and these openings must not be blocked or covered. The openings should never be blocked by placing the video product on a bed, sofa, rug, or similar surface. This video product should never be placed in a built-in installation such as a bookcase or rack unless proper ventilation is provided or the manufacturer's instructions have been adhered to.

10. Power Sources

This video product should be operated only from the type of power source indicated on the marking label. If you are not sure of the type of power supply to your home, consult your appliance dealer or local power company. For video products intended to operate from battery power, or other sources, refer to the operating instructions.

11. Plug

This item is applicable only to the video products having the plug connected to the wall outlet.

- a. Polarized Plug — This plug will fit into the power outlet only one way. This is a safety feature. If you are unable to insert the plug fully into the outlet, try reversing the plug. If the plug should still fail to fit, contact your electrician to replace your obsolete outlet. Do not defeat the safety purpose of the polarized plug.
- b. Three-Wire Grounding-Type Plug — This plug having a third (grounding) pin will only fit into a grounding-type power outlet. This is a safety feature. If you are unable to insert the plug into the outlet, contact your electrician to replace your obsolete outlet. Do not defeat the safety purpose of the grounding-type plug.

12. Power-Cord Protection

Power-supply cords should be routed so that they are not likely to be walked on or pinched by items placed upon or against them, paying particular attention to cords at plugs, convenience receptacles, and the point where they exit from the appliance.

13. Lightning

For added protection for this video product during a lightning storm, or when it is left unattended and unused for long periods of time, unplug it from the power source. This will prevent damage to the video product due to lightning and power-line surges.

14. Overloading

Do not overload power source and extension cords as this can result in a risk of fire or electric shock.

15. Object and Liquid Entry

Never push objects of any kind into this video product through openings as they may touch dangerous voltage points or short out parts that could result in a fire or electric shock. Never spill liquid of any kind on the video product.

16. Inflammable and Explosive Substance

Avoid using this video product where there are gases, and also where there are inflammable and explosive substances in the immediate vicinity.

17. Heavy Shock or Vibration

When carrying this video product around, do not subject the video product to heavy shock or vibration.

18. Servicing

Do not attempt to service this video product yourself as opening or removing covers may expose you to dangerous voltage or other hazards. Refer all servicing to qualified service personnel.

19. Damage Requiring Service

Unplug this video product from the power source and refer servicing to qualified service personnel under the following conditions:

- a. When the power-supply cord or plug is damaged.
- b. If liquid has been spilled, or objects have fallen into the video product.
- c. If the video product has been exposed to rain or water.
- d. If the video product does not operate normally by following the operating instructions. Adjust only those controls that are covered by the operating instructions as an improper adjustment of other controls may result in damage and will often require extensive work by a qualified technician to restore the video product to its normal operation.
- e. If the video product has been dropped or the cabinet has been damaged.
- f. If the video product exhibits a distinct change in performance—this indicates a need for service.

20. Replacement Parts

When replacement parts are required, be sure the service technician has used replacement parts specified by the manufacturer or have the same characteristics as the original part. Unauthorized substitutions may result in fire, electric shock or other hazards.

21. Safety Check

Upon completion of any service or repairs to this video product, ask the service technician to perform safety checks to determine that the video product is in proper operating condition.