

**PT780 Legacy® Series
Pan/Tilts**

**Installation/
Operation Manual**

C342M-D (8/05)

CONTENTS

Section	Page
1.0 GENERAL	5
1.1 IMPORTANT SAFEGUARDS AND WARNINGS	5
2.0 DESCRIPTION	6
2.1 MODELS	6
3.0 INSTALLATION	7
3.1 MOUNTING	7
3.2 PAN AND TILT LIMIT STOP ADJUSTMENTS	8
3.3 ENCLOSURE INSTALLATION	10
3.4 ELECTRICAL INSTALLATION	10
3.4.1 LRD41 Series Legacy® Receiver/Drivers	10
3.4.2 All Control Equipment Except LRD41 Series Legacy® Receiver/Drivers	10
4.0 OPERATION	19
5.0 MAINTENANCE	20
5.1 SERVICE MANUAL	21
6.0 SPECIFICATIONS	22
7.0 WARRANTY AND RETURN INFORMATION	24

LIST OF ILLUSTRATIONS

Figure		Page
1	Removing the Screws	8
2	Releasing the Covers	8
3	Removing the Covers	8
4	Hooking Cover Halves	8
5	Tilt Limit Adjustment	9
6	Pan Limit Adjustment	9
7	Replacing the Cover Halves	9
8	Securing the Cover Halves	9
9	Connector Assembly	11
10	Wiper On/Off Connection	12
11	Pan/Tilt Adjustments	20
12	PT780 Series Dimension Drawing	23

LIST OF TABLES

Table		Page
A-1	37-Position Connector Pin Designations for Pan/Tilts with EH4700L and EH5700L Enclosures	13
A-2	37-Position Connector Pin Designations for Pan/Tilts with EH8106L Enclosures	14
B	Requirements to Wire Power to Pan and Tilt Motors	15
C	Maximum Cable Distances Using RB24 or RB115 Relay Boxes	16
D	Requirements to Wire Power to Camera Enclosure	17
E	Requirements to Wire Power for Optional Heater Blanket	17
F	24 VAC Wiring Distances Chart	18

REVISION HISTORY

Manual	Date	Comments
C342M	1991	Original version.
C342M-A	4/96	Consolidated C344M and C345M manuals into C342M-A manual. Revised installation instructions. Created manual history and updated to new manual style.
	4/96	Updated wiring instructions for EH8106L enclosures.
C342M-B	6/97	Put into new format. Revised exploded assembly diagrams in Figures 12, 13, 14 and 15 to show movement of the wire clamp and grommet from the side to the bottom of the pan spindle per ECO #96-352. Pan spindle nut (part # 9004004COMP) replaced by snap ring (part # 80010019) per ECO #97-194. Figure 4 revised.
C342M-C	11/98	Revised Section 5.0, Maintenance. Moved Section 6.0, Exploded Assembly Diagrams, to new service manual (C342SM). Repaginated manual.
C342M-D	8/05	Added ratings per ECO 05-10441. Added WEEE statement.

(This page intentionally left blank.)

1.0 GENERAL

1.1 IMPORTANT SAFEGUARDS AND WARNINGS

Prior to installation and use of this product, the following WARNINGS should be observed.

1. Installation and servicing should only be done by qualified service personnel and conform to all local codes.
2. The weight of the camera/lens and enclosure shall not exceed 40 lb (18.14 kg) with 12VDC pan/tilts or 52 lb (23.59 kg) with 24 VAC or 120 VAC pan/tilts.
3. Only use replacement parts recommended by Pelco.
4. After replacement/repair of this unit's electrical components, conduct a resistance measurement between line and exposed parts to verify the exposed parts have not been connected to line circuitry.
5. The installation method and materials should be capable of supporting four times the weight of the enclosure, pan/tilt, camera and lens combination.

The product and/or product manual may bear the following marks:



This symbol indicates that dangerous voltage constituting a risk of electric shock is present within this unit.



This symbol indicates that there are important operating and maintenance instructions in the literature accompanying this unit.

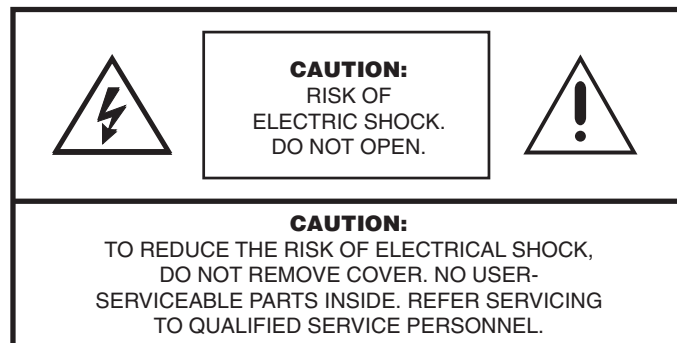

Please thoroughly familiarize yourself with the information in this manual prior to installation and operation.

2.0 DESCRIPTION

The PT780 Legacy® Series pan/tilt units are designed for medium, indoor/outdoor use.

Only Legacy Series enclosures can be mounted on the pan/tilt units. These enclosures are the EH4700L and EH5700L environmental enclosures and the EH8106L pressurized enclosure. Pelco's RediLINK™ connector makes it simple and quick for you to install an enclosure. The weight of the enclosure with camera and lens must not exceed 40 pounds (18.14 kg) with the 12 VDC pan/tilt units or 52 pounds (23.56 kg) with the 24 VAC or 120 VAC pan/tilt units.

You can easily remove the clamshell covers from the sides of the pan/tilt units to access all internal parts without having to remove the camera enclosure. This makes it easy to service the units and to adjust the pan and tilt limit stops.

2.1 MODELS

The PT780 Series consists of the following models:

PT780P	Heavy-duty, indoor/outdoor pan/tilt, 120 VAC.
PT780P/PP	PT780P with preset positioning capabilities.
PT780SL	PT780P with 360° pan rotation.
PT780SL/PP	PT780SL with preset positioning capabilities.
PT780-VS	Heavy-duty, indoor/outdoor, variable-speed pan/tilt, 12 VDC.
PT780-VS/PP	PT780VS with preset positioning capabilities.
PT780-VSSL	PT780VS with 360° pan rotation.
PT780-VSSL/PP	PT780-VSSL with preset positioning capabilities.
PT780-24P	Heavy-duty, indoor/outdoor pan/tilt, 24 VAC.
PT780-24P/PP	PT780-24P with preset positioning capabilities.
PT780-24SL	PT780-24P with 360° pan rotation.
PT780-24SL/PP	PT780-24SL with preset positioning capabilities.

3.0 INSTALLATION

3.1 MOUNTING

NOTE: *To insure proper wiring and operation of your equipment, it is recommended that you test the pan/tilt unit and associated equipment in your facility before installing it in the field. Refer to Sections 3.2 through 3.4.*



CAUTION: *The PT780 pan/tilt units are designed for upright or inverted (base up) operation. Never mount the pan/tilt horizontally.*

NOTE: *If you mount your pan/tilt unit in the inverted position, you must install a rain cover (part number 90010018).*

Attach the pan/tilt unit to a wall or ceiling mount. Follow the instructions that are provided with the mount. Make sure the mounting surface and the selected mount can support four times the combined weight of the pan/tilt unit and the camera enclosure (including the camera and lens). The pan/tilt unit weighs approximately 21.5 pounds (9.68 kg). Refer to the manuals for your enclosure, camera, and lens for the weights of those items.

3.2 PAN AND TILT LIMIT STOP ADJUSTMENTS

1. Remove the covers.
 - a. Refer to Figure 1 and remove the Phillips screw on each side of the pan/tilt unit.
 - b. Refer to Figure 2 and place your hands under the cover halves. Exert a strong, upward force to release the covers from their internal latching devices.
 - c. Refer to Figure 3 and pull the cover halves away from the pan/tilt unit.
 - d. Set the covers down or hang them by the eyelets inside the covers (refer to Figure 4). The wire and hook on which to hang the covers is not provided.

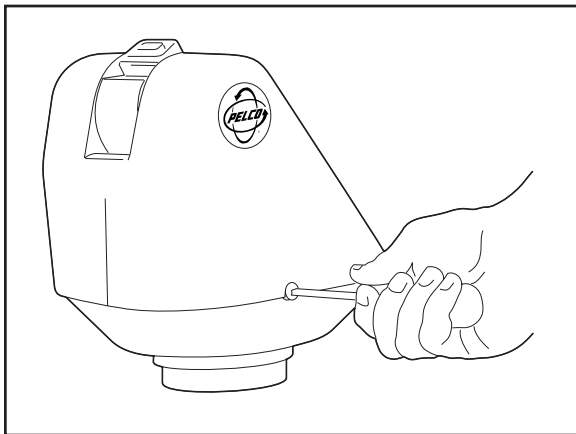

Figure 1. Removing the Screws

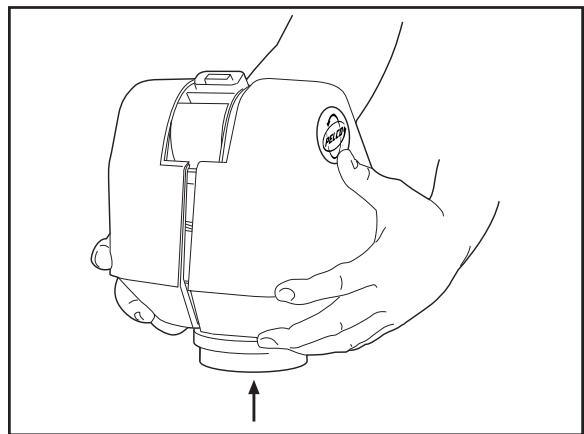

Figure 2. Releasing the Covers

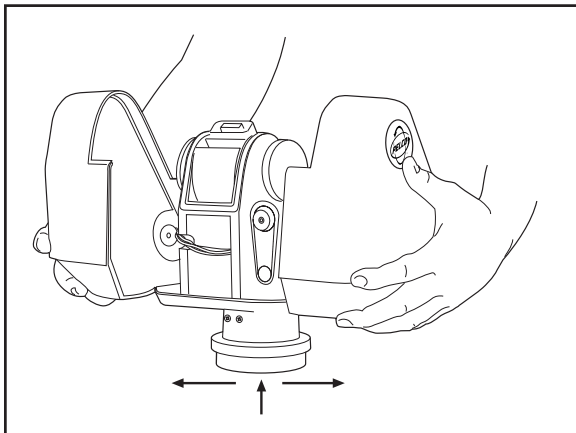

Figure 3. Removing the Covers

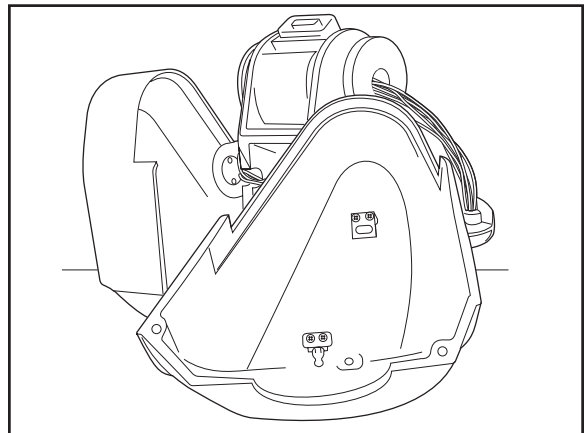

Figure 4. Hooking Cover Halves



CAUTION: Never remove the tilt limit stops.

NOTE: SL models do not have pan limit stops.



CAUTION: Never loosen or remove the center stop. It is for protection of wiring inside the pan/tilt unit. If the center stop is loosened or removed, the wiring inside the pan/tilt unit will be damaged.

NOTE: If you need to readjust the pan and tilt limit stops after you install the enclosure, you can do this without removing the enclosure, no matter what angle the enclosure might be tilted.

2. Adjust the tilt limit stops.

Refer to Figure 5 for the location of the tilt limit stops. The tilt limit stop closest to the front of the pan/tilt unit limits the downward movement. The tilt limit stop closest to the back of the pan/tilt unit limits the upward movement. These movements are reversed if the pan/tilt unit is installed upside down.

Loosen the screw in the limit stop that you want to adjust. Position the limit stop in the desired location by sliding it in the circular groove. Tighten the screw to lock the limit stop in position.

3. Adjust the pan limit stops.

Refer to Figure 6 for the location of the pan limit stops. Loosen the screw in the limit stop that you want to adjust. Position the limit stop in the desired location by sliding it on the circular ring. Tighten the screw to lock the limit stop in position.

4. Replace the covers.

- a. Refer to Figure 7 and grasp one cover half in each hand and position the covers on each side of the pan/tilt unit.
- b. Bring the two cover halves together, aligning the two pins in one cover half with the mating holes in the other cover half.
- c. When the cover halves are together, press downward, as shown in Figure 8, to force the covers into their latches.
- d. Replace the screws in the covers.

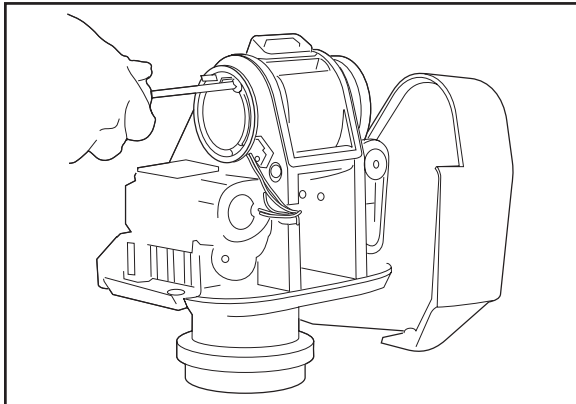

Figure 5. Tilt Limit Adjustment

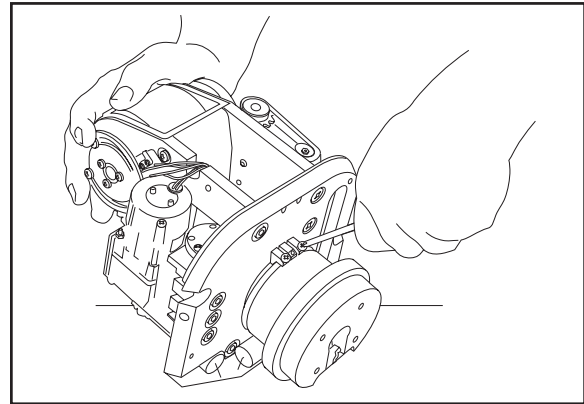

Figure 6. Pan Limit Adjustment

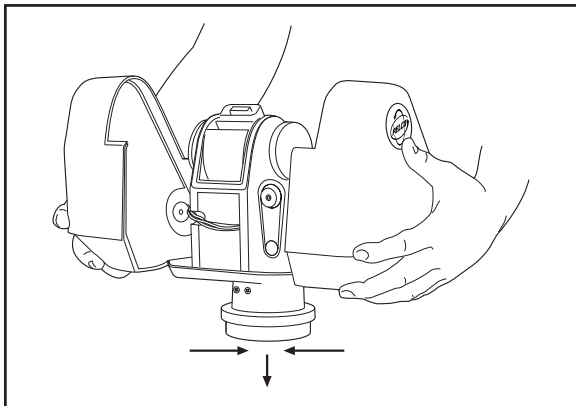

Figure 7. Replacing the Cover Halves

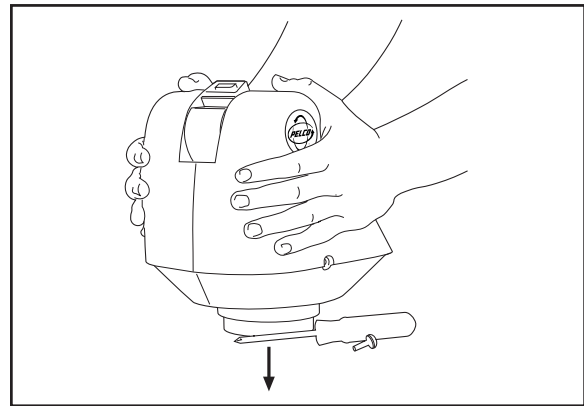

Figure 8. Securing the Cover Halves

3.3 ENCLOSURE INSTALLATION

Attach the camera enclosure to the pan/tilt unit. Follow the instructions that are provided with the enclosure.

3.4 ELECTRICAL INSTALLATION

3.4.1 LRD41 Series Legacy® Receiver/Drivers

Connect the 37-pin round connector from the pan/tilt unit to the mating connector on the receiver/driver.

3.4.2 All Control Equipment Except LRD41 Series Legacy® Receiver/Drivers

Make the interconnecting cable to link the 37-pin round connector from the pan/tilt unit to the control equipment.

For cable requirements, refer to the following tables and chart:

Table A-1:	Connector Pin Designations for Pan/Tilts with EH4700L and EH5700L Enclosures
Table A-2:	Connector Pin Designations for Pan/Tilts with EH8106L Enclosures
Tables Band C:	Requirements to Wire Power to Pan and Tilt Motors
Table D:	Requirements to Wire Power to Camera Enclosure
Table E:	Requirements to Wire Power to Optional Heater Blanket
Table F:	24 VAC Wiring Distances Chart

The following are some recommended common installation practices:

- For unshielded conductors, use jacketed, stranded, multiconductor cable, with additional conductors than needed for future servicing and/or additions. Use color-coded conductors for ease of wiring and to identify functions at a later date.
- Keep a wiring diagram with the system for later reference.

Refer to Figure 9 and the following steps to construct the cable:

1. Slide the unshielded and coaxial cables through the cable shell and rubber boot.
2. Strip one inch of the jacket from the cables.
3. For the unshielded conductors, strip 1/8 inch of insulation from the individual wires.
4. For the coax, unwrap the braid and twist it into a single conductor. Strip 1/8 inch of insulation from the center conductor. If you are using two coax cables - one for video output and one for camera synchronization - twist the braid from the two coax cables together.
5. Insert the end of each wire into a socket and crimp the end of the socket over the wire's insulation. This provides strain relief for the bare wire. Then crimp or solder the bare wire to the socket.
6. Refer to Table A and push each socket into the proper hole of the 37-pin connector until it snaps into place. Once a socket snaps into place, it can not be removed without a special AMP tool.
7. Slide the cable shell down the cabling and screw it to the 37-pin connector.
8. Screw the cable clamp to the cable shell.
9. Connect the 37-pin connector to the mating connector on the pan/tilt unit.
10. To make a watertight assembly, use RTV silicone on both sides of the connector to fill any gaps between the cable clamps, cable shell, and cable.

WARNING: To prevent damage to the wiper, if your enclosure has one, AC high to turn on the wiper (pin 25 of the 37-pin connector) must come from the same circuit that provides power to the wiper (pin 15 of the 37-pin connector). This is because the wiper and the on/off control share the same AC neutral (pin 16). See Figure 10.

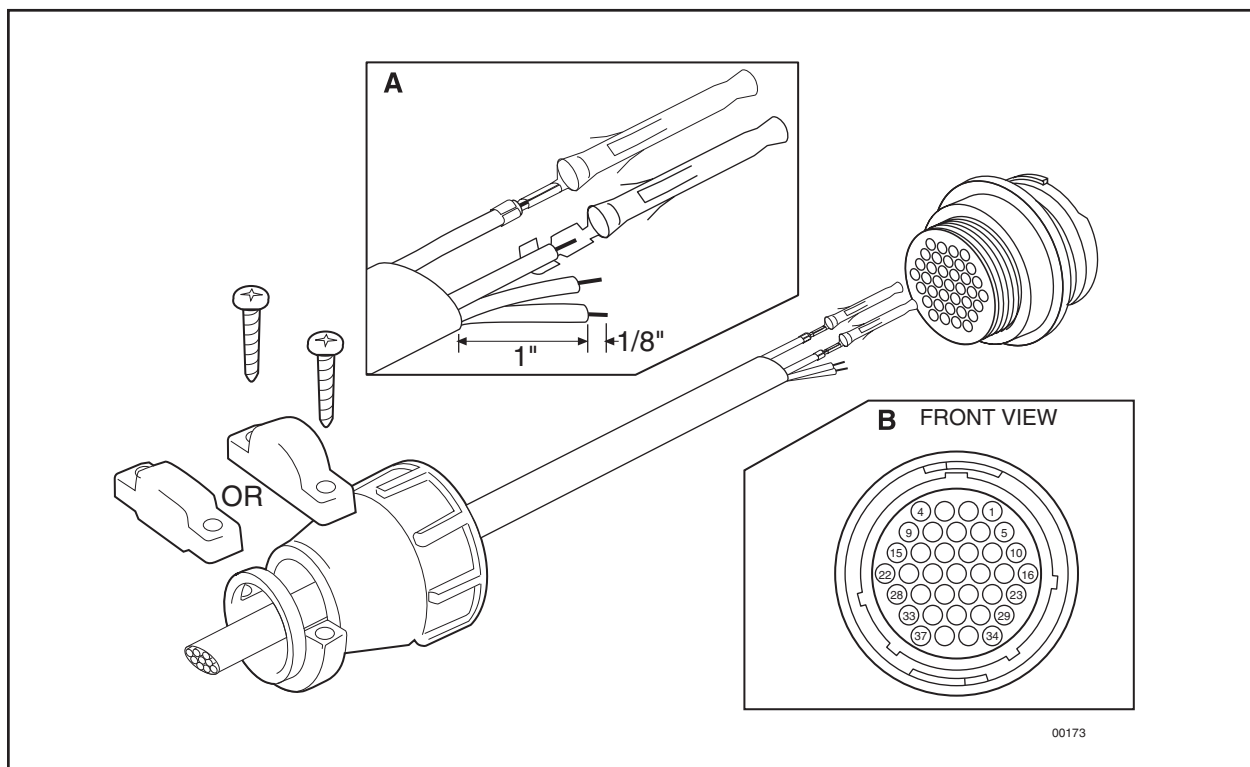

Figure 9. Connector Assembly

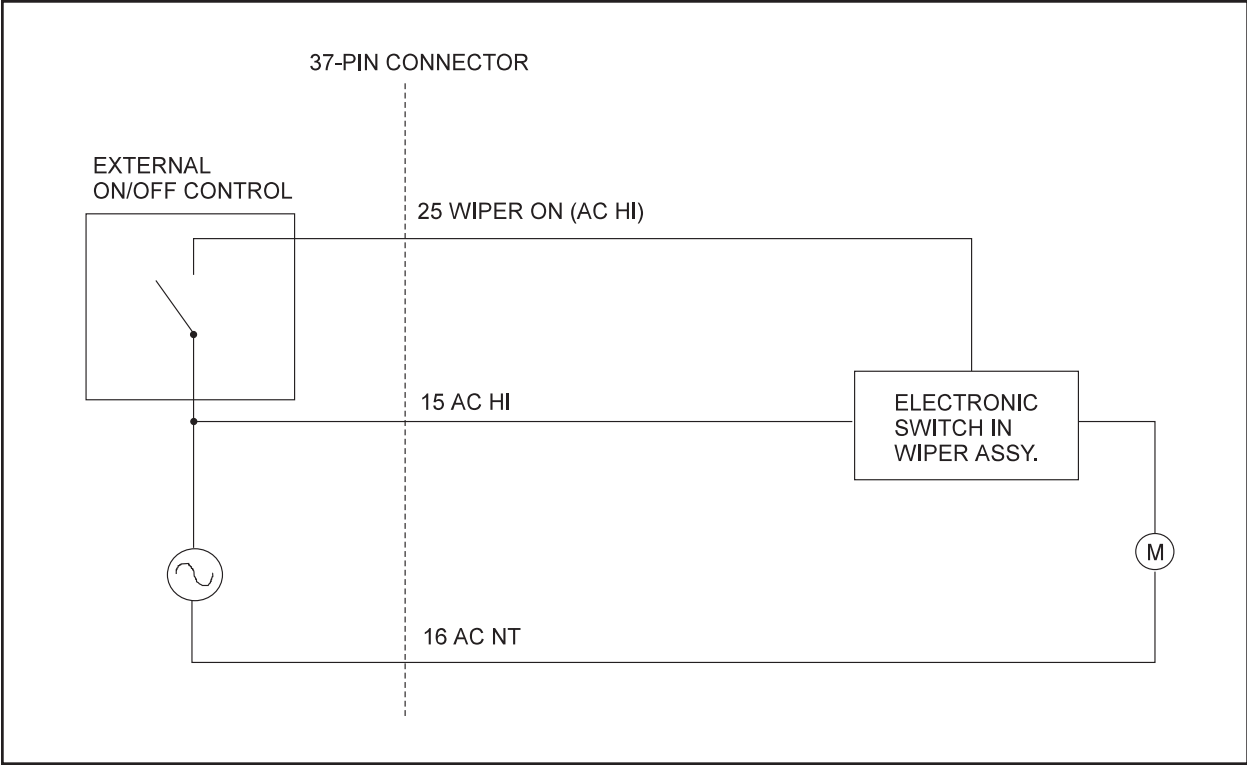

Figure 10. Wiper On/Off Connection

Table A-1. 37-Position Connector Pin Designations for Pan/Tilts with EH4700L and EH5700L Enclosures

Pin #	Function	PT780P PT780-24P PT780-VS	PT780P/PP PT780-24P/PP PT780-VS/PP	PT780-SL PT780-24SL PT780-VSSL	PT780-SL/PP PT780-24SL/PP PT780-VSSL/PP
Coaxial Cable					
27/4 30/4	Video Signal/Ground Sync Signal/Ground	• (B)	• (B)	• (B)	• (B)
Unshielded Conductors					
3	Left	•	•	•	•
7	Right	•	•	•	•
6	Up	•	•	•	•
5	Down	•	•	•	•
1	Common	(A)	(A)	(A)	(A)
8	Safety Ground	•	•	•	•
10	Iris	(B)	(B)	(B)	(B)
11	Focus	•	•	•	•
12	Zoom	•	•	•	•
9	Camera Power (AC High)	(C)	(C)	(C)	(C)
14	Camera Power (AC Neutral)	(C)	(C)	(C)	(C)
13	Lens Common	•	•	•	•
15	Enclosure Power (AC High)	•	•	•	•
16	Enclosure Power (AC Neutral)	•	•	•	•
31	Heater Blanket (AC High)	(D)	(D)	(D)	(D)
32	Heater Blanket (AC Neutral)	(D)	(D)	(D)	(D)
25	Wiper	•	•		
26	Washer (Future)	•	•		
17	Spare	•	•		
18	Spare	•	•		
28	PP Ground		•		•
29	PP 5V		•		•
34	PP Focus		•		•
35	PP Zoom		•		•
33	PP Pan		•		•
36	PP Tilt		•		•
37	PP SL				•

Pins 2 and 19-24 are not used.

(A) Not used on VS models.

(B) Not available on some SL models. Check the 37-pin connector from the pan/tilt to see if pin is present.

(C) Use if camera power is different from enclosure power.

(D) Wire only if you ordered a heater blanket with your pan/tilt unit.

Table A-2. 37-Position Connector Pin Designations for Pan/Tilts with EH8106L Enclosures

Pin #	Function	PT780P PT780-24P PT780-VS	PT780P/PP PT780-24P/PP PT780-VS/PP	PT780-SL PT780-24SL PT780-VSSL	PT780-SL/PP PT780-24SL/PP PT780-VSSL/PP
Coaxial Cable					
27/4	Video Signal/Ground	•	•	•	•
Unshielded Conductors					
3	Left	•	•	•	•
7	Right	•	•	•	•
6	Up	•	•	•	•
5	Down	•	•	•	•
1	Common	(A)	(A)	(A)	(A)
8	Safety Ground	•	•	•	•
10	Iris	(B)	(B)	(B)	(B)
11	Focus	•	•	•	•
12	Zoom	•	•	•	•
9	Camera Power (AC High)	•	•	•	•
14	Camera Power (AC Neutral)	•	•	•	•
13	Lens Common	•	•	•	•
15	Enclosure Power (AC High)	•	•	•	•
16	Enclosure Power (AC Neutral)	•	•	•	•
31	Heater Blanket (AC High)	(C)	(C)	(C)	(C)
32	Heater Blanket (AC Neutral)	(C)	(C)	(C)	(C)
18	Pressure Switch	(D)	(D)		
19	Pressure Switch	(D)	(D)		
28	PP Ground		•		•
29	PP 5V		•		•
34	PP Focus		•		•
35	PP Zoom		•		•
33	PP Pan		•		•
36	PP Tilt		•		•
37	PP SL				•

Pins 2, 17, and 20-26 are not used.

(A) Not used on VS models.

(B) Not available on some SL models. Check the 37-pin connector from the pan/tilt to see if pin is present.

(C) Wire only if you ordered a heater blanket with your pan/tilt unit.

(D) Wire only if you ordered a pressure switch for your enclosure.

Table B. Requirements to Wire Power to Pan and Tilt Motors

Wire Size	Maximum Cable Length*		
	6 Conductors**	7 Conductors***	5 Conductors****
120 VAC PT780P Models 20 AWG 18 AWG 16 AWG	1,370 ft (417 m) 2,180 ft (664 m) 3,470 ft (1,057 m)	2,745 ft (836 m) 4,370 ft (1,331 m) 6,940 ft (2,115 m)	
24 VAC PT780-24P Models 20 AWG 18 AWG 16 AWG	59 ft (17.98 m) 94 ft (28.65 m) 149 ft (45.41 m)	118 ft (35.96 m) 188 ft (57.30 m) 298 ft (90.83 m)	
12 VDC PT780-VS Models 20 AWG 18 AWG 16 AWG			24 ft (7.3 m) 38 ft (11.58 m) 60 ft (18.28 m)

- * Cable distances are based on:
 26.4 VAC output from the controller (24 VAC models), or
 132 VAC output from the controller (120 VAC models), or
 12 VDC output from the controller (12 VDC models), and
 10% cable loss with both motors (pan and tilt) running simultaneously

- ** Six conductors for operating pan and tilt motors:
- | | |
|--------------------------------|---------------|
| Pin number in 37-pin connector | Function |
| 3 | Left |
| 7 | Right |
| 6 | Down |
| 5 | Up |
| 1 | Motor Common |
| 8 | Safety Ground |

*** Same as six conductors except uses two wires for motor common.

**** Same as six conductors except motor common is not used.

NOTE: Operation of the pan/tilt unit at lower than 12 VDC, 24 VAC, or 120 VAC, depending on model, will result in reduced load and speed capability.

Table C. Maximum Cable Distances Using RB24 or RB115 Relay Boxes

Wire Size	Maximum "A" Distance	Maximum "B" Distance
20 AWG* 18 AWG 16 AWG	5,800 ft (1,768 m) 8,250 ft (2,515 m) 13,000 ft (3,962 m)	Use Table B
<p>* Not recommended for reliable service between control and relay box. NOTE: Relay boxes can not be used with 12 VDC pan/tilts.</p>		

The diagram illustrates the wiring setup. A 'CONTROL' box is connected to a 'RELAY BOX' box. The 'RELAY BOX' is connected to a 'REQUIRED EXTERNAL POWER SUPPLY' and a bell-shaped device. Distance 'A' is the length of the cable between the CONTROL and RELAY BOX. Distance 'B' is the length of the cable between the RELAY BOX and the bell-shaped device.

Table D. Requirements to Wire Power to Camera Enclosure

EH8106L: Power for the camera and heaters are separate. Refer to your camera manual for the camera wattage to determine the size of wire to use. Wire camera power through pins 9 and 14 of the 37-pin connector. The heaters use a total of 80 watts; wire through pins 15 and 16 of the 37-pin connector.

EH4700L and EH5700L: To determine the wire gauge to use, add up the wattages for the different accessories inside your enclosure.

CAUTION: There are two ways to supply power to the camera - when the power requirements for the camera and enclosure's accessories are the same (for example, if the camera and accessories use 24 VAC), and when the power requirements for the camera and the enclosure's accessories are different (for example, if the camera uses 24 VAC and the accessories use 120 VAC).

If the camera uses the **same power** as the accessories, add the wattage of the camera to wattages of the accessories. Wire power for the camera and accessories through pins 15 and 16 of the 37-pin connector.

If the camera uses **different power** than the accessories, wire power for the camera through pins 9 and 14 of the 37-pin connector. Wire power for the accessories through pins 15 and 16 of the 37-pin connector.

EH4700L Enclosures		EH5700L Enclosures	
120 VAC Models		120 VAC Models	
Blower	8 watts	Blower	15 watts
Heater	60 watts	Heater	90 watts
Defroster	15 watts	Defroster	30 watts
		Window wiper	15 watts*
24 VAC Models		24 VAC Models	
Blower	8 watts	Blower	10 watts
Heater	50 watts	Heater	50 watts
Defroster	15 watts	Defroster	30 watts
		Window wiper	15 watts*
230 VAC Models		230 VAC Models	
Blower	8 watts	Blower	15 watts
Heater	55 watts	Heater	70 watts
Defroster	15 watts	Defroster	30 watts
		Window wiper	15 watts*

* **WARNING:** To prevent damage to the wiper, AC high to turn on the wiper (pin 25 of the 37-pin connector) must come from the same circuit that provides power to the wiper (pin 15 of the 37-pin connector). This is because the wiper and the on/off control share the same AC neutral (pin 16). See Figure 10.

Table E. Requirements to Wire Power for Optional Heater Blanket

Option	Power
HB1	120 VAC (40 watts)
HB2	24 VAC (40 watts)
HB3	230 VAC (40 watts)

Table F. 24 VAC Wiring Distances Chart

The following are the recommended maximum distances for 24 VAC applications and are calculated with a 10-percent voltage drop. (Ten percent is generally the maximum allowable voltage drop for AC-powered devices.)

EXAMPLE: An enclosure that requires 80 vA and is installed 35 feet (10 m) from the transformer would require a minimum wire gauge of 20 Awg.

NOTE: Distances are calculated in feet; values in parentheses are meters.

	Wire Gauge					
	20	18	16	14	12	10
10	283 (86)	451 (137)	716 (218)	1142 (348)	1811 (551)	2880 (877)
20	141 (42)	225 (68)	358 (109)	571 (174)	905 (275)	1440 (438)
30	94 (28)	150 (45)	238 (72)	380 (115)	603 (183)	960 (292)
40	70 (21)	112 (34)	179 (54)	285 (86)	452 (137)	720 (219)
50	56 (17)	90 (27)	143 (43)	228 (69)	362 (110)	576 (175)
60	47 (14)	75 (22)	119 (36)	190 (57)	301 (91)	480 (146)
70	40 (12)	64 (19)	102 (31)	163 (49)	258 (78)	411 (125)
80	35 (10)	56 (17)	89 (27)	142 (43)	226 (68)	360 (109)
90	31 (9)	50 (15)	79 (24)	126 (38)	201 (61)	320 (97)
100	28 (8)	45 (13)	71 (21)	114 (34)	181 (55)	288 (87)
110	25 (7)	41 (12)	65 (19)	103 (31)	164 (49)	261 (79)
120	23 (7)	37 (11)	59 (17)	95 (28)	150 (45)	240 (73)
130	21 (6)	34 (10)	55 (16)	87 (26)	139 (42)	221 (67)
140	20 (6)	32 (9)	51 (15)	81 (24)	129 (39)	205 (62)
150	18 (5)	30 (9)	47 (14)	76 (23)	120 (36)	192 (58)
160	17 (5)	28 (8)	44 (13)	71 (21)	113 (34)	180 (54)
170	16 (4)	26 (7)	42 (12)	67 (20)	106 (32)	169 (51)
180	15 (4)	25 (7)	39 (11)	63 (19)	100 (30)	160 (48)
190	14 (4)	23 (7)	37 (11)	60 (18)	95 (28)	151 (46)
200	14 (4)	22 (6)	35 (10)	57 (17)	90 (27)	144 (43)

Total vA consumed

Maximum distance from transformer to load

4.0 OPERATION

Refer to the manual for your control equipment for operating the pan/tilt unit.

If your enclosure has the heater blanket option, it is thermostatically controlled to turn on at 40° F (4.44° C) and turn off at 60° F (15.56° C). The heater blanket allows operation of the pan/tilt unit to -50° F (-45.56° C).

5.0 MAINTENANCE

If you need to remove the enclosure, protect the RediLINK™ connector area against moisture, dust, dirt, etc. Failure to do so could result in a bad connection. Also, damage to the pan/tilt unit or enclosure could occur when power is turned on.

The following servicing should be done every six months with average use.

1. Remove the PT780's outer casing. (Refer to step 1 under Section 3.2, PAN AND TILT STOP LIMIT ADJUSTMENTS.)
2. Inspect the gaskets around the cover, tilt shaft, and spindle for damage.
3. Refer to Figure 11. It shows the parts locations of the tilt assembly. Look for similar orientations of parts when adjusting the pan assembly.
4. Check the backlash adjustment.

Backlash is the slack or binding in a pan and tilt base mount. Determine backlash by lifting the mount assembly, grasping the base, and wiggling it. There should not be any play or binding between the gear (A) and worm drive (B). Play or binding indicates a backlash problem.

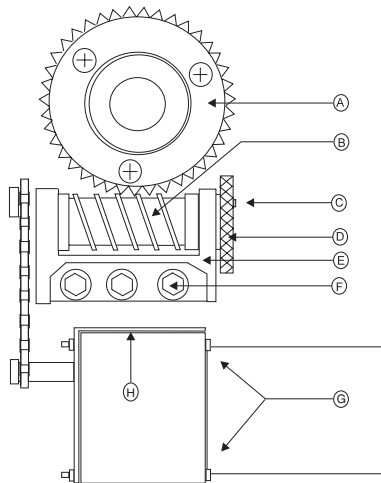

Figure 11. Pan/Tilt Adjustments

- One backlash problem involves a worm and worm gear connection loose enough to cause slipping or tight enough to cause binding.
 - The second involves a too-loose or too-tight chain, usually causing symptoms similar to the worm and worm gear problem—slipping or binding.
- a. Verify that the worm drive (B) is fully seated in the worm gear (A). If it is not:
 - (1) Locate the worm-driven gear for either the pan or the tilt motor linkage. Loosen the three hex screws (F) holding the worm in place, but leave enough thread in place to hold the assembly on the mount.
 - (2) Using your thumbs, gently move the worm forward or pull the assembly back from the worm gear to either tighten or loosen the gear spacing to the worm gear. Move the base of the pan and tilt to check the adjustment.
 - (3) If you get movement in the base, press a finger down in the middle of the worm assembly. If you get no movement in the base, use your thumb and forefinger to pull the worm assembly back until you get movement.
 - (4) When the spacing is correct, tighten the hex screws. Start with the middle screw to ensure proper spacing.
 - (5) Remove the screw (C) in the gear train nut (D).
 - (6) Tighten the gear train nut to remove any play.
 - (7) Line up the hole in the gear train nut with the nearest hole in the gear train bracket (E).
 - (8) Replace the screw.
 - b. Refer to Figure 11. Adjust chain tension, if needed:
 - (1) Locate the pan or tilt motor on the assembly. Loosen the hex screws (G) that hold the motor to its mounting bracket. Depending on which motor assembly you are adjusting, there will be either three (pan) or four (tilt). (Only two screws are shown in Figure 11.)

- (2) Using a screwdriver, pry the motor down at H to tighten for the correct chain tension. (You should not be able to freely move the motor with your finger, nor should it be so tight that it will not move at all as this usually leads to binding.)
- (3) Tighten the hex screws.
- c. Using a controller, you should now be able to move the PT780 without looseness or binding. If you have any problems, contact Pelco's Technical Support Department.
5. Lubricate the chains. Use a Teflon chain lubricant, such as TriFlon™.
6. Replace the covers. (Refer to step 4 under Section 3.2, PAN AND TILT STOP LIMIT ADJUSTMENTS.)

5.1 SERVICE MANUAL

If you need to repair your unit, obtain a service manual in one of the following ways:

- Go to Pelco's web site at <ftp://www.pelco.com> and find service manual C342SM.
- Contact Pelco's Literature Department and request service manual C342SM.

6.0 SPECIFICATIONS

Specifications apply to all models unless specified otherwise.

MECHANICAL

Pan Rotation:	Movement in horizontal plane: 0-355° 0-360° (SL models only)
Pan Speed	
12 VDC models only:	1-17°/sec ±1° (maximum load)
All others:	9°/sec ±1° (no load condition)
Tilt Rotation:	90° down from horizontal 60° up from horizontal
Tilt Speed	
12 VDC models only:	1-4°/sec ±.5° (maximum load)
All others:	3°/sec ±.5° (no load condition)
Torque Output	
12 VDC models only:	18.3 ft lb (24.8 Nm) at rated voltage and 75° (23.9°C)
All others:	23.8 ft lb (32.3 Nm) at rated voltage and 75° (23.9°C)
Maximum Load	
12 VDC models only:	40 lb (18.14 kg) at specified torque
All others:	52 lb (23.55 kg) at specified torque
Pan/Tilt Drive System:	Delrin™ worm gear. Ground and polished stainless steel worm
Pan/Tilt Bearings:	Roller thrust bearings and bronze Oilite bushings
Lubricants	
Bearings:	NLGI #2; Lithium complex grease fortified with molybdenum
Chain:	Teflon chain lubricant (for example, TriFlon™)
Braking:	Friction

ELECTRICAL

Input Voltage	
12 VDC models only:	12 VDC
All others:	120 VAC or 24 VAC, 50/60 Hz
vA Required	
Input Voltage	120 VAC
Pan:	19.2 vA (.16 A)
Tilt:	32.4 vA (.27 A)
Total vA Required:	51.6 vA (.43 A)
Input Voltage	24 VAC
Pan:	21.6 vA (.9 A)
Tilt:	24 vA (1 A)
Total vA Required:	45.6 vA (1.9 A)
Input Voltage	12 VDC
Pan:	17.04 vA (1.42 A)
Tilt:	12.48 vA (1.04 A)
Total vA Required:	29.52 vA (2.46 A)
Maximum Current:	2 amps per conductor (SL models only)

Connectors: Amp CPC type, mate supplied (37 pins)

Motor Type
 12 VDC models only: 12 VDC continuous duty. DC permanent magnet
 All others: Single phase, instantaneous reversing, induction type. 120 VAC or 24 VAC, 50/60 Hz, impedance protected. 50% duty cycle; 30-minute rating

Limit Switches: 5 amp, 250 VAC maximum, 10 million cycle rating, internal adjustment

GENERAL

Construction
 Pan/Tilt: Aluminum exterior; painted steel and aluminum interior parts
 Worm Gear: Delrin™ premium performance acetal
 Worm Drive: Ground and polished stainless steel

Dimensions: See Figure 12

Environment: Indoor/outdoor
 -10° to 140 °F (-23° to 60° C)

Weight
 Unit: 21.5 lb (9.68 kg) approximate
 Shipping: 25 lb (11.32 kg)

Ratings: Meets NEMA Type 3R and IP54 standards

(Design and specifications subject to change without notice.)



This equipment contains electrical or electronic components that must be recycled properly to comply with Directive 2002/96/EC of the European Union regarding the disposal of waste electrical and electronic equipment (WEEE). Contact your local dealer for procedures for recycling this equipment.

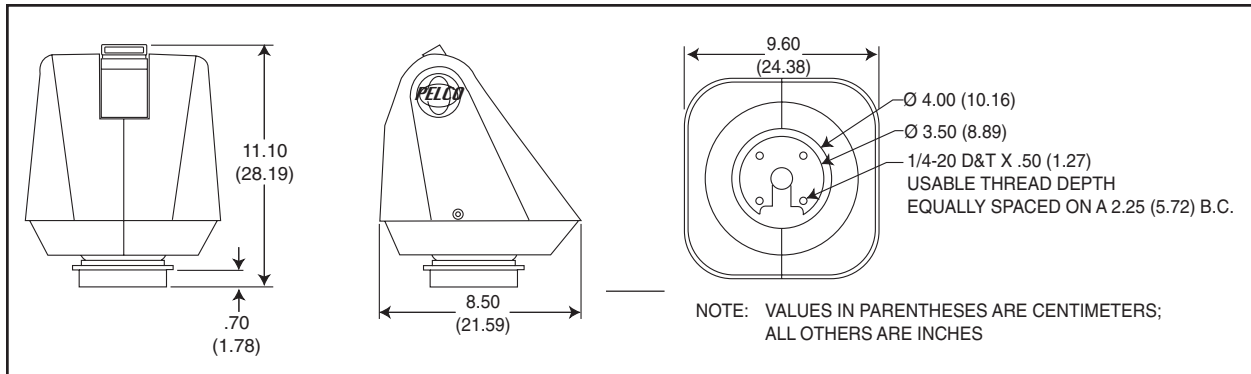

Figure 12. PT780 Series Dimension Drawing

7.0 WARRANTY AND RETURN INFORMATION

WARRANTY

Pelco will repair or replace, without charge, any merchandise proved defective in material or workmanship for a period of one year after the date of shipment.

Exceptions to this warranty are as noted below:

- Five years on FT/FR8000 Series fiber optic products.
- Three years on Genex® Series products (multiplexers, server, and keyboard).
- Three years on Camclosure® and fixed camera models, except the CC3701H-2, CC3701H-2X, CC3751H-2, CC3651H-2X, MC3651H-2, and MC3651H-2X camera models, which have a five-year warranty.
- Two years on standard motorized or fixed focal length lenses.
- Two years on Legacy®, CM6700/CM6800/CM9700 Series matrix, and DF5/DF8 Series fixed dome products.
- Two years on Spectra®, Esprit®, ExSite™, and PS20 scanners, including when used in continuous motion applications.
- Two years on Esprit® and WW5700 Series window wiper (excluding wiper blades).
- Eighteen months on DX Series digital video recorders, NVR300 Series network video recorders, and Endura™ Series distributed network-based video products.
- One year (except video heads) on video cassette recorders (VCRs). Video heads will be covered for a period of six months.
- Six months on all pan and tilts, scanners or preset lenses used in continuous motion applications (that is, preset scan, tour and auto scan modes).

Pelco will warrant all replacement parts and repairs for 90 days from the date of Pelco shipment. All goods requiring warranty repair shall be sent freight prepaid to Pelco, Clovis, California. Repairs made necessary by reason of misuse, alteration, normal wear, or accident are not covered under this warranty.

Pelco assumes no risk and shall be subject to no liability for damages or loss resulting from the specific use or application made of the Products. Pelco's liability for any claim, whether based on breach of contract, negligence, infringement of any rights of any party or product liability, relating to the Products shall not exceed the price paid by the Dealer to Pelco for such Products. In no event will Pelco be liable for any special, incidental or consequential damages (including loss of use, loss of profit and claims of third parties) however caused, whether by the negligence of Pelco or otherwise.

The above warranty provides the Dealer with specific legal rights. The Dealer may also have additional rights, which are subject to variation from state to state.

If a warranty repair is required, the Dealer must contact Pelco at (800) 289-9100 or (559) 292-1981 to obtain a Repair Authorization number (RA), and provide the following information:

1. Model and serial number
2. Date of shipment, P.O. number, Sales Order number, or Pelco invoice number
3. Details of the defect or problem

If there is a dispute regarding the warranty of a product which does not fall under the warranty conditions stated above, please include a written explanation with the product when returned.

Method of return shipment shall be the same or equal to the method by which the item was received by Pelco.

RETURNS

In order to expedite parts returned to the factory for repair or credit, please call the factory at (800) 289-9100 or (559) 292-1981 to obtain an authorization number (CA number if returned for credit, and RA number if returned for repair).

All merchandise returned for credit may be subject to a 20% restocking and refurbishing charge. Goods returned for repair or credit should be clearly identified with the assigned CA or RA number and freight should be prepaid. Ship to the appropriate address below.

If you are located within the continental U.S., Alaska, Hawaii or Puerto Rico, send goods to:

Service Department
Pelco
3500 Pelco Way
Clovis, CA 93612-5699

If you are located outside the continental U.S., Alaska, Hawaii or Puerto Rico and are instructed to return goods to the USA, you may do one of the following:

If the goods are to be sent by a COURIER SERVICE, send the goods to:

Pelco
3500 Pelco Way
Clovis, CA 93612-5699 USA

If the goods are to be sent by a FREIGHT FORWARDER, send the goods to:

Pelco c/o Expeditors
473 Eccles Avenue
South San Francisco, CA 94080 USA
Phone: 650-737-1700
Fax: 650-737-0933

© Pelco, the Pelco logo, Spectra, Esprit, Genex, Legacy, and Camclosure are registered trademarks of Pelco.

™ Endura and ExSite are trademarks of Pelco.

© Copyright 2005, Pelco. All rights reserved.