

Grizzly Industrial, Inc.®

FINE WIRE UPHOLSTERY STAPLER MODEL H5626/7 INSTRUCTION MANUAL



Model H5626



Model H5627

COPYRIGHT © SEPTEMBER, 2003 BY GRIZZLY INDUSTRIAL, INC.
WARNING: NO PORTION OF THIS MANUAL MAY BE REPRODUCED IN ANY SHAPE
OR FORM WITHOUT THE WRITTEN APPROVAL OF GRIZZLY INDUSTRIAL, INC.
PRINTED IN TAIWAN

SAFETY

WARNING

For Your Own Safety Read Instruction Manual Before Operating This Equipment

The purpose of safety symbols is to attract your attention to possible hazardous conditions. This manual uses a series of symbols and signal words which are intended to convey the level of importance of the safety messages. The progression of symbols is described below. Remember that safety messages by themselves do not eliminate danger and are not a substitute for proper accident prevention measures.

DANGER

Indicates an imminently hazardous situation which, if not avoided, WILL result in death or serious injury.

WARNING

Indicates a potentially hazardous situation which, if not avoided, COULD result in death or serious injury.

CAUTION

Indicates a potentially hazardous situation which, if not avoided, MAY result in minor or moderate injury. It may also be used to alert against unsafe practices.

NOTICE

This symbol is used to alert the user to useful information about proper operation of the equipment.

WARNING

Safety Instructions For Pneumatic Tools

1. **KEEP ALL SAFETY DEVICES IN PLACE** and in working order.
2. **REMOVE ADJUSTING KEYS AND WRENCHES.** Form habit of checking to see that keys and adjusting wrenches are removed from tool before operation.
3. **KEEP WORK AREA CLEAN.** Cluttered areas and benches invite accidents.
4. **DO NOT USE IN DANGEROUS ENVIRONMENT.** DO NOT use pneumatic tools in damp or wet locations, or where any flammable or noxious fumes may exist. Keep work area well lighted.
5. **KEEP CHILDREN AND VISITORS AWAY.** All children and visitors should be kept at a safe distance from work area.
6. **MAKE WORKSHOP CHILD PROOF** with padlocks, master switches, or by removing air hoses from tools.
7. **DO NOT FORCE TOOL.** It will do the job better and safer at the rate for which it was designed.
8. **USE THE RIGHT TOOL.** DO NOT force tool or attachment to do a job for which it was not designed.
9. **DO NOT USE UNDER THE INFLUENCE OF DRUGS OR ALCOHOL.**

WARNING

Safety Instructions For Pneumatic Tools

10. **USE PROPER AIR HOSE** for the tool. Make sure your air hose is in good condition and is long enough to reach your work without stretching.
11. **WEAR PROPER APPAREL.** DO NOT wear loose clothing, gloves, neckties, rings, bracelets, or other jewelry which may get caught in moving parts. Non-slip footwear is recommended. Wear a protective hair covering to contain long hair.
12. **ALWAYS USE SAFETY GLASSES.** Also use a face or dust mask if cutting operation is dusty. Everyday eyeglasses only have impact resistant lenses, they are NOT safety glasses.
13. **WEAR APPROVED HEARING PROTECTION.**
14. **SECURE WORK.** Use clamps or a vise to hold work when practical. It is safer than using your hand and frees both hands to operate tool.
15. **DO NOT OVERREACH.** Keep proper footing and balance at all times.
16. **MAINTAIN TOOLS WITH CARE.** Keep tools lubricated and clean for best and safest performance. Follow instructions for lubricating and changing accessories.
17. **REDUCE THE RISK OF UNINTENTIONAL FIRING.** DO NOT carry tool with hand on trigger and always disconnect from air when not in use.
18. **DISCONNECT TOOLS** before servicing and changing accessories.
19. **USE THE RECOMMENDED ACCESSORIES.** Consult the owner's manual for recommended accessories. The use of improper accessories may cause risk of injury.
20. **CHECK DAMAGED PARTS.** Before further use of the tool, a guard or other part that is damaged should be carefully checked to determine that it will operate properly and perform its intended function. Check for alignment of moving parts, binding of moving parts, breakage of parts, mounting, and any other conditions that may affect its operation. A guard or other part that is damaged should be properly repaired or replaced.
21. **NEVER LEAVE UNATTENDED TOOL CONNECTED TO AIR.** Disconnect the air hose and DO NOT leave tool until it is relieved of any built up pressure.
22. **NEVER ALLOW UNTRAINED USERS TO USE THIS TOOL WHILE UNSUPERVISED.**
23. **IF YOU ARE UNSURE OF THE INTENDED OPERATION, STOP USING THE TOOL.** Seek formal training or research books or magazines that specialize in pneumatic tools.

WARNING

Basic Stapler Safety

In addition to the rules stated in the previous section, and those in the warning boxes throughout this manual, please observe the following safety tips for your new stapler:

1. **READ THIS ENTIRE MANUAL BEFORE OPERATING THE STAPLER.**
2. **ALWAYS DISCONNECT AIR FROM THE STAPLER** whenever servicing or installing staples. During maintenance, a stapler connected to air may fire accidentally, causing serious personal injury.
3. **DO NOT PLACE HANDS NEAR STAPLE POINT OF ENTRY.** Staple can deflect and tear through the surface of the workpiece, puncturing your hand or fingers.
4. **NEVER CONNECT THE STAPLER TO PRESSURIZED OXYGEN OR OTHER COMBUSTIBLE GASES** as a power source. Only use filtered, lubricated, and regulated compressed air.
5. **NEVER USE GASOLINE OR OTHER FLAMMABLE LIQUIDS TO CLEAN THE STAPLER.** Vapors in the tool will ignite by a spark and cause the tool to explode.
6. **DO NOT CARRY THE STAPLER BY ANY OTHER PART THAN THE HANDLE,** and do not carry the stapler by the air hose.
7. **DO NOT KEEP THE TRIGGER PULLED WHEN CARRYING OR HOLDING THE TOOL.**
8. **DO NOT USE A CHECK VALVE OR ANY OTHER FITTING** that allows air to remain in the tool.

WARNING

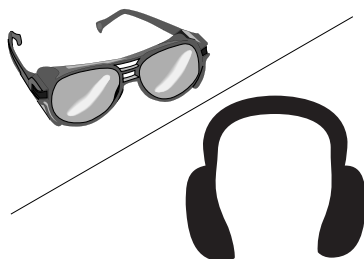

Operating this stapler can propel objects into the air, causing immediate eye damage. To protect yourself, always wear American National Standards Institute (ANSI) approved safety glasses or goggles when operating this equipment. In addition, this stapler discharges at 85-90 decibels. To protect your hearing, always wear ANSI approved ear protection when operating this stapler.

WARNING



Never point this stapler at yourself or another person! Always pay attention to the direction this stapler is pointed. Use this tool with respect and caution to lessen the possibility of operator or bystander injury. Ignoring this warning may result in serious personal injury.

INTRODUCTION

Commentary

We are proud to offer the Grizzly Model H5626/H5627 Upholstery Stapler. This model is part of a growing Grizzly family of fine power tools. When used according to the guidelines set forth in this manual, you can expect years of trouble-free, enjoyable operation and proof of Grizzly's commitment to customer satisfaction.

This stapler fires 22 gauge fine wire, 1/4"-5/8" crown staples and features an easy clear magazine.

We are pleased to provide this manual with the Model H5626/H5627. It was written to encourage safety considerations and guide you through general operating procedures and maintenance. This manual represents our effort to produce the best documentation possible.

The specifications, details, and photographs in this manual represent the Model H5626/H5627 as supplied when the manual was prepared. However, owing to Grizzly's policy of continuous improvement, changes may be made at any time with no obligation on the part of Grizzly. If you have any comments regarding this manual, please write to us at the address below:

Grizzly Industrial, Inc.
% Technical Documentation
P.O. Box 2069
Bellingham, WA 98227-2069

Most importantly, we stand behind our tools. If you have any service questions or parts requests, please call or write us at the location listed below.

Grizzly Industrial, Inc.
1203 Lycoming Mall Circle
Muncy, PA 17756

Phone: (570) 546-9663

Fax: (800) 438-5901

E-Mail: techsupport@grizzly.com

Web Site: <http://www.grizzly.com>



WARNING

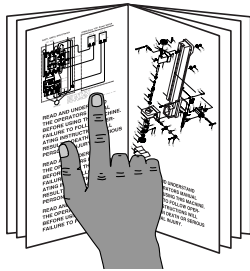

Read the manual before assembly and operation. Become familiar with this tool, its safety instructions, and its operation before beginning any work. Serious personal injury may result if safety or operational information is not understood or followed.

Compressed Air System

The Model H5626/H5627 is designed to be operated at 60-100 psi. **Do not exceed the maximum operating pressure for your model.**

Before you use your new stapler, install the 1/4" quick connect fitting that comes with the stapler. Install a female 1/4" fitting on the air hose. Regulate the air pressure on your air compressor to barely over the minimum psi for your model.

Many pneumatic tools benefit from an in-line filter/lubricator/regulator unit. Using this unit protects your tool from damaging water build-up, allows you to adjust and maintain constant air pressure to your tool, and saves you the inconvenience of having to manually lubricate your tool every time you use it. Check the current Grizzly catalog for availability of this unit. If you plan on installing a filter/lubricator/regulator unit in your compressed air system, always follow the connection instructions that come with the unit.

! WARNING

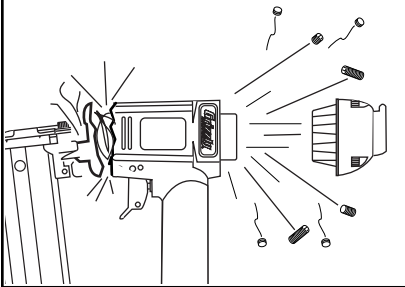

Exceeding the maximum permissible operating pressure may cause the stapler to explode, blowing metal fragments in all directions. To protect yourself from serious personal injury, DO NOT allow your air compressor to exceed the recommended pressure when connected to this stapler!

Oiling Stapler

Special oil has been included with you new Grizzly stapler to help maintain its useful life. Place one drop of oil in the stapler air inlet (as shown in **Figure 1**) before every use. Wipe off any excess oil near the stapler exhaust to avoid dust build-up. When the oil that was included with the stapler has been completely used, replace with Grizzly Model G2820 Pneumatic Tool Oil.

Another option to manual oiling would be to install a lubricator in your air compressor line. If your air compressor line already has a lubricator, then regular lubrication of your stapler will not be necessary. Just make sure there is always oil in the lubricator.

As mentioned before, the best option is to install a filter/lubricator/regulator unit in your air line.

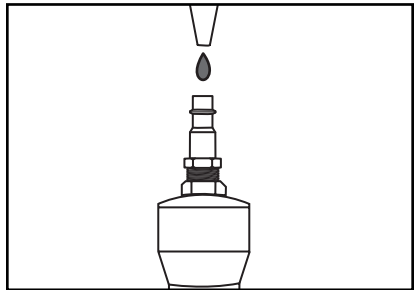

Figure 1. Lubricating stapler via air inlet.

OPERATION

Loading Stapler

To load your stapler:

1. **Disconnect the air supply from the stapler!**
2. Push the magazine latch in the direction shown in **Figure 2**.

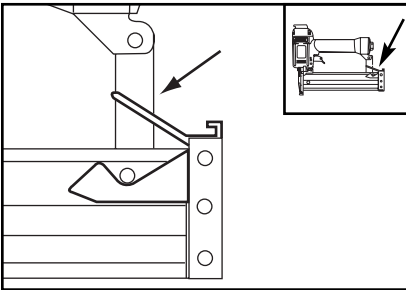

Figure 2. Releasing magazine latch.

3. Pull back the magazine cover until it stops.
4. Point the stapler up and insert a stick of staples into the magazine as shown in **Figure 3**. Make sure that the pointed ends of the staples point in the same direction as the stapler nose piece.

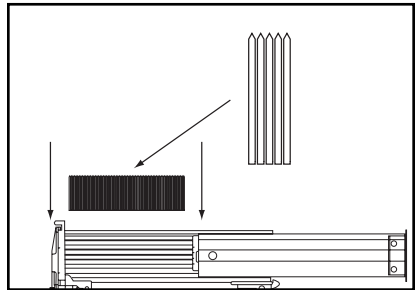

Figure 3. Loading staples into stapler.

5. Push the magazine cover forward until the magazine latch locks in place.

Operating Stapler

If you have not read the safety instructions in this manual, do not operate the stapler.

Every time you operate your stapler, place one drop of the included oil into the quick connect fitting where the stapler connects to the air supply.

To operate your stapler:

1. Connect the air supply to the quick connect fitting.
2. Test the loaded stapler for proper penetration. Hold the stapler perpendicular to the surface of a piece of clean scrap wood that is thick enough for the length of staples you have loaded.
3. Before pressing the trigger, make sure your free hand is positioned out of the way of a potential path of a sta-

ple in case of deflection. (Deflection is caused when the staple changes its path, resulting in the staple puncturing the surface of the workpiece as shown in **Figure 4**.)

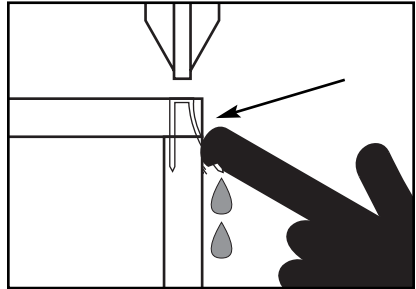

Figure 4. Example of staple deflection.

Besides damaging your workpiece, deflection can cause injury if your free hand is securing the workpiece in the location that the staple deflects.

4. Press the trigger. If the staple drove into the wood far enough, continue with your intended operations. If the staple either went too far or not far enough, then adjust the air pressure. More air pressure will make the staple go deeper and less air pressure will decrease the staple penetration.

Speed Adjustment

The Model H5627 features staple firing speeds from .5 to 16 staples per second.

To adjust the staple firing speed:

1. **Disconnect the stapler from the air supply!**
2. Release the speed adjustment lock by holding the speed adjustment screw in place with a screwdriver while rotating the speed adjustment lock counter clockwise.
3. Rotate the speed adjustment screw counter clockwise to increase the firing speed or clockwise to slow the firing speed (**Figure 5**).

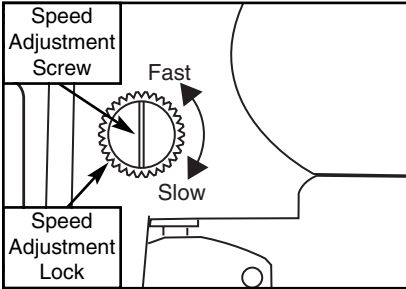

Figure 5. H5627 speed adjustment screw.

4. To test fire the stapler push the stapler against a scrap of wood, hold the trigger down continuously, and move the stapler across the wood.
5. When the firing speed has been adjusted, secure the speed adjustment screw by placing a flat head screwdriver in the slot and twisting the speed adjustment lock clockwise until tight.

Clearing Jammed Staples

A jammed staple must be cleared before using the stapler again.

To clear a jammed staple:

1. **Disconnect the stapler from the air supply!**
2. Open the magazine cover and pull the magazine all the way back.
3. Remove stick of staples.
4. Remove jammed staple with needle nose pliers.

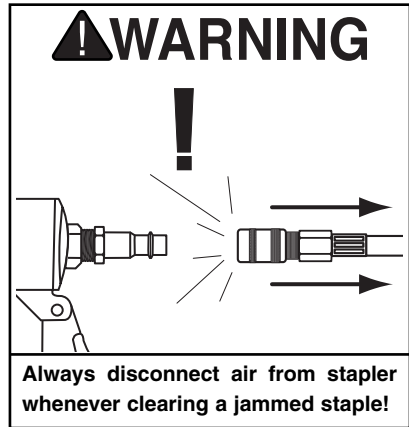

Cleaning Stapler

Use a good solvent to clean the nose assembly of the stapler. Always be sure that the stapler is dry before using it again.

Do not allow dust, chips, sand, etc. into the air connectors or into the body of the stapler; this may result in leaks and damage to the stapler and the air couplings.

WARNING



Never use use gasoline or other flammable liquids to clean this tool. Vapors in the tool may ignite, causing the tool to explode. Ignoring this warning may lead to serious personal injury or even death!

WARNING

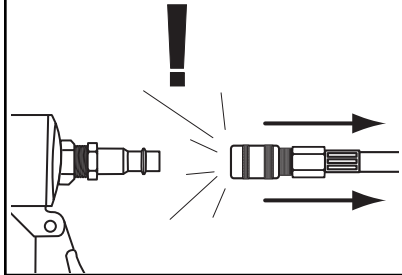

Always disconnect air from stapler whenever servicing! During maintenance, a stapler connected to air may fire accidentally, causing serious personal injury!

Replacing Pistons/O-Rings

If you use your stapler day in and day out, Grizzly offers repair pistons as cheap insurance against wasted down time and lost profits in the event that a piston or piston shaft becomes worn out.

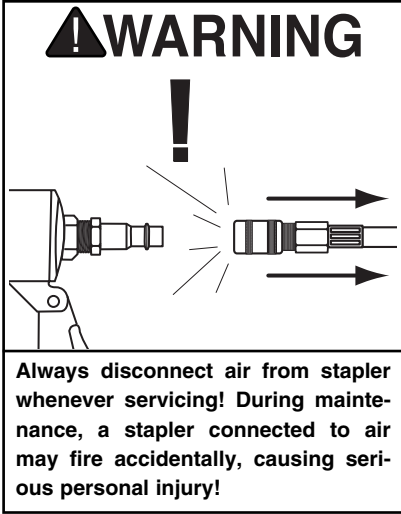

To replace a piston:

1. **Disconnect the stapler from the air supply!**
2. Remove all staples from the magazine cartridge.
3. Remove the 4 cap screws from the stapler exhaust cap on the Model H5626, or unscrew the exhaust cap on the Model H5627.
4. Remove the exhaust cap as shown in **Figure 6**.
5. The top of the piston should now be visible inside the cylinder, which is housed in the head of the stapler.
6. Open the magazine.

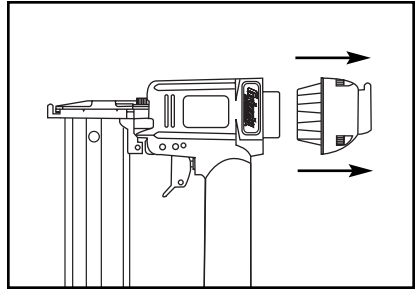
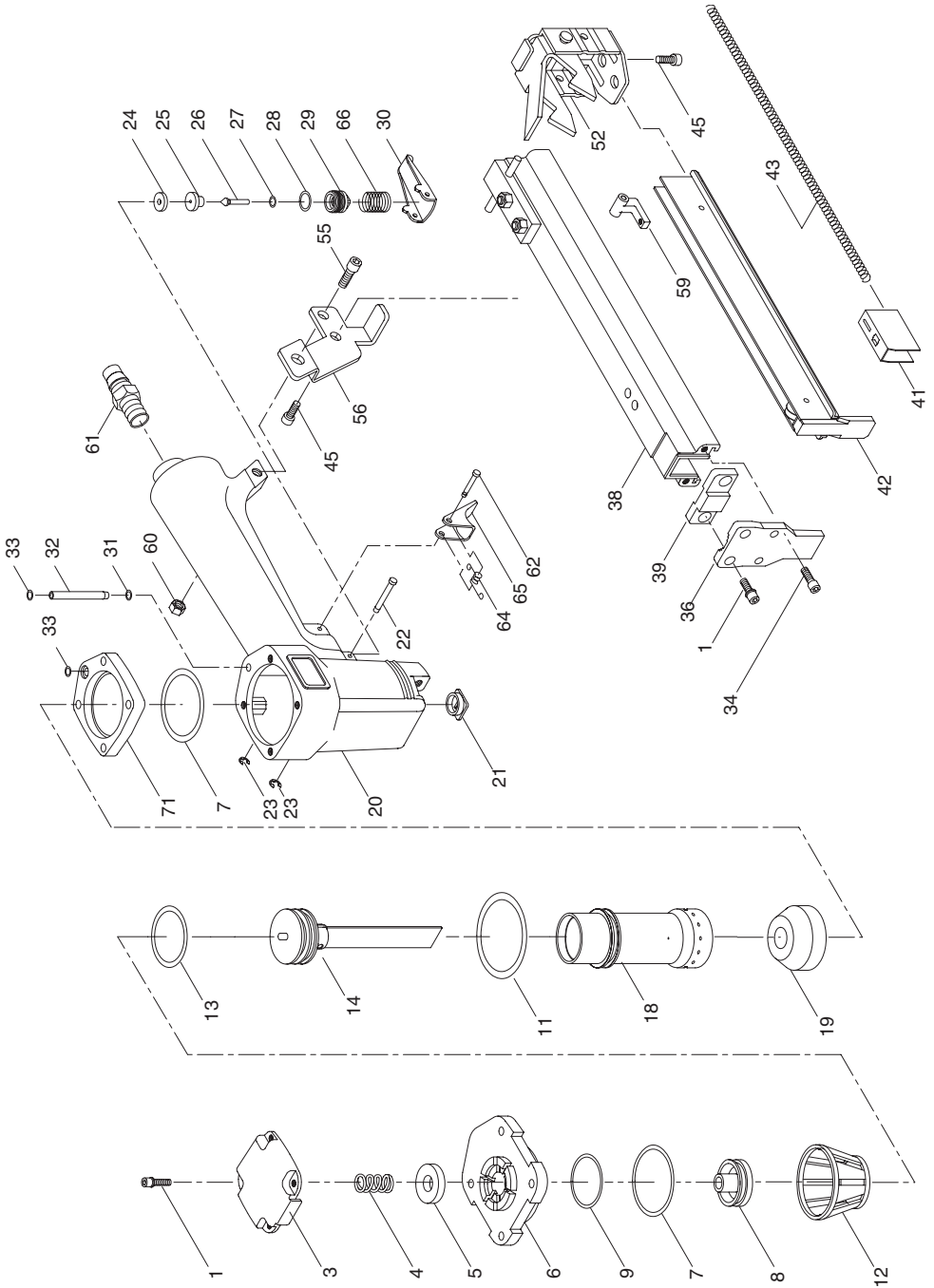

Figure 6. Removing stapler exhaust cap.

7. Watch the discharge area and push the top of the piston with your finger. You will see the piston shaft slide down the discharge area.
8. With a long flathead screwdriver or similarly shaped tool, push the piston shaft back inside the stapler until you can grip the piston head and remove it from the cylinder. (Be careful not to scratch the discharge area when pushing the piston shaft with the screwdriver.)
9. Place a new O-ring on the new piston and apply a thin film of the stapler lubricating oil on the O-ring.
10. Insert the new piston in the cylinder. Make sure that the grooves on the piston shaft line up with those on the guide. The new piston should easily slide into the cylinder. **Do not force the piston into the cylinder!** If the piston is not easily inserted, double-check the alignment of the piston shaft with the grooves on the guide.
11. After the piston is inserted correctly, close the magazine. Replace the rear cap assembly and tighten the 4 cap screws.
12. For more assistance, or to install a complete O-ring set, refer to the appropriate breakdown diagram in the back of this manual.

MAINTENANCE NOTES

H5626 PART BREAKDOWN



REF	PART #	DESCRIPTION
01	PSB95M	CAP SCR M5-.8 X 30
03	PH5626003	CAP COVER
04	PH5626004	SPRING
05	PH5626005	SEAL
06	PH5626006	CAP
07	PH5626007	O-RING
08	PH5626008	HEAD VALVE ASM.
09	PH5626009	O-RING
11	PH5626011	O-RING
12	PH5626012	COLLAR
13	PH5626013	O-RING
14	PH5626014	DRIVER ASSEMBLY
18	PH5626018	CYLINDER
19	PH5626019	BUMPER
20	PH5626020	BODY
21	PH5626021	DRIVER GUIDE
22	PH5626022	PIN
23	PEC01M	E-CLIP 3MM
24	PH5626024	SEAL
25	PH5626025	TRIGGER VALVE HD
26	PH5626026	TRIGGER VALVE STEM
27	PH5626027	O-RING
28	PH5626028	O-RING
29	PH5626029	TRIGGER VALVE GUIDE

REF	PART #	DESCRIPTION
30	PH5626030	TRIGGER
31	PH5626031	O-RING
32	PH5626032	TUBE
33	PH5626033	O-RING
34	PSB17M	CAP SCR M4-.7 X 10
36	PH5626036	NOSE
38	PH5626038	MAGAZINE
39	PH5626039	SET PLATE
41	PH5626041	PUSHER
42	PH5626042	STAPLE GUIDE UNIT
43	PH5626043	SPRING
45	PSB114M	BTN HD CAP SCR M4-.7 X 8
52	PH5626052	END CORE ASM.
55	PSB15M	CAP SCR M5-.8 X 20
56	PH5626056	BRACKET
59	PH5626059	SET PLATE
60	PLN02M	LOCK NUT M5-.8
61	PH5626061	1/4" NPT CONNECT
62	PH5626062	PIN
64	PH5626064	SPRING
65	PH5626065	TRIGGER
66	PH5626066	SPRING
67	PSB18M	CAP SCR M4-.7 X 8
71	PH5626071	AIR ROOM

H5627 PART BREAKDOWN

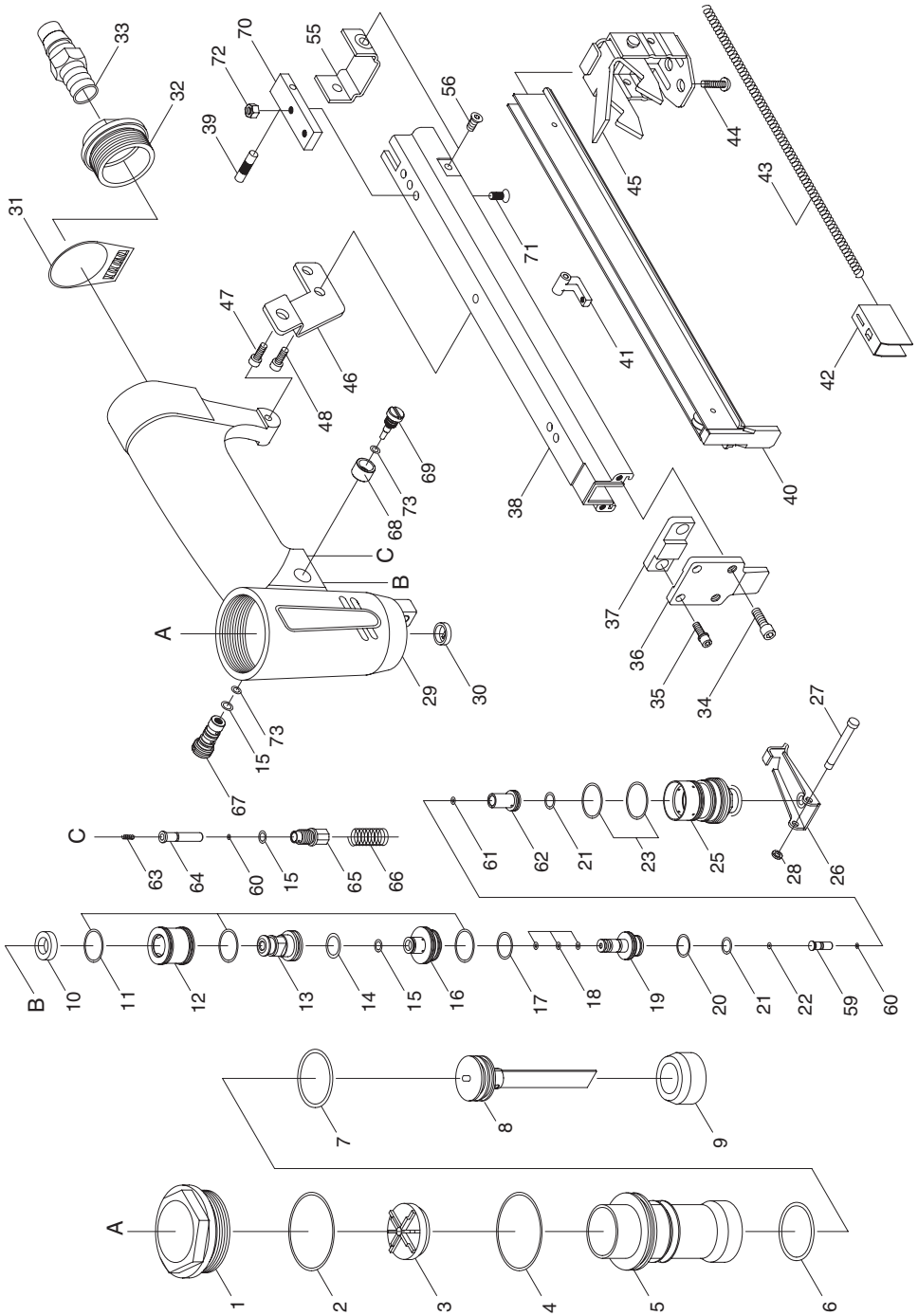

REF	PART #	DESCRIPTION
01	PH5627001	CAP
02	PH5627002	O-RING
03	PH5627003	CYL. PRESS RING
04	PH5627004	O-RING
05	PH5627005	CYLINDER
06	PH5627006	O-RING
07	PH5627007	O-RING
08	PH5627008	DRIVER ASSEMBLY
09	PH5627009	BUMPER
10	PH5627010	COLLAR
11	PH5627011	O-RING
12	PH5627012	VALVE
13	PH5627013	VALVE PLUNGER
14	PH5627014	O-RING
15	PH5627015	O-RING
16	PH5627016	COLLAR
17	PH5627017	O-RING
18	PH5627018	O-RING
19	PH5627019	VALVE PLUNGER
20	PH5627020	O-RING
21	PH5627021	O-RING
22	PH5627022	O-RING
23	PH5627023	O-RING
25	PH5627025	PLUNGER CAP
26	PH5627026	TRIGGER
27	PH5627027	PIN
28	PH5627028	O-RING
29	PH5627029	BODY
30	PH5627030	DRIVER GUIDE
31	PH5627031	EXHAUST DIFFUSER
32	PH5627032	COVER
33	PH5627033	1/4" NPT CONNECT

REF	PART #	DESCRIPTION
34	PSB23M	CAP SCR M4-.7 X 12
35	PSB53M	CAP SCR M5-.8 X 18
36	PH5627036	NOSE
37	PH5627037	SET PLATE
38	PH5627038	MAGAZINE
39	PH5627039	SHAFT
40	PH5627040	STAPLE GUIDE UNIT
41	PH5627041	SET PLATE
42	PH5627042	PUSHER
43	PH5627043	SPRING
44	PSB114M	BTN HD CAP SCR M4-.7 X 8
45	PH5627045	END CORE ASM.
46	PH5627046	BRACKET
47	PSB24M	CAP SCR M5-.8 X 16
48	PSB23M	CAP SCR M4-.7 X 12
55	PH5627055	SET PLATE
56	PH5627056	FLT HD SCR M4-.7 X 6
59	PH5627059	PLUNGER
60	PH5627060	O-RING
61	PH5627061	O-RING
62	PH5627062	SLEEVE
63	PH5627063	SPRING
64	PH5627064	PLUNGER
65	PH5627065	PLUNGER CAP
66	PH5627066	SPRING
67	PH5627067	REGULATOR ASM.
68	PH5627068	PILOT SLEEVE
69	PH5627069	RAPID FIRE ADJ KNOB
70	PH5627070	SET BLOCK
71	PFH33M	FLT HD SCR M4-.7 X 11
72	PLN01M	LOCK NUT M4-.7
73	PH5627073	O-RING

TROUBLESHOOTING

PROBLEM	CAUSE	ACTION
Air leaking at trigger valve area.	1. O-rings in trigger valve housing are damaged.	1. O-rings must be replaced & operation of safety yoke must be checked.
Air leaking between housing and hose.	1. Loose screws in housing. 2. Damaged O-ring. 3. Loose air fitting.	1. Tighten screws. 2. Replace O-ring. 3. Tighten air fitting.
Air leaking between housing and cap assembly.	1. Damaged seal.	1. Replace damaged seals.
Tool skips staples while discharging.	1. Air leaks. 2. Dirt in nose. 3. Dirt or damage prevents staples from moving freely in magazine. 4. Inadequate air flow to tool. 5. Worn O-ring on piston or lack of lubrication. 6. Damaged O-rings on trigger valve. 7. Worn bumper. 8. Cap seal leaking.	1. Tighten screws and fittings. 2. Clean nose. 3. Clean magazine and inspect/repair damage. 4. Check fitting, hose, compressor & air pressure. 5. Replace piston O-ring. Lubricate. 6. Replace trigger valve O-rings. 7. Replace bumper. 8. Replace cap seal.
Tool runs slowly or has a loss of power.	1. Stapler is not sufficiently lubricated. 2. Broken spring in cap assembly. 3. Exhaust port in cap is blocked.	1. Lubricate stapler. 2. Replace spring. 3. Clean or replace damaged internal parts.
Fasteners frequently jam the stapler.	1. Staples are the wrong size. 2. Staples are bent. 3. Magazine or nose screws are loose. 4. Driver or driver guide are worn or damaged.	1. Use correct staples. 2. Use undamaged staples 3. Tighten magazine and nose screws. 4. Replace worn or damaged parts.
Stapler does not fire.	1. Staple is jammed in magazine or discharge area. 2. Piston shaft is damaged. 3. Air pressure too low.	1. Clear stapler magazine or discharge area. 2. Replace piston shaft. 3. Check/increase air pressure.

WARRANTY AND RETURNS

Grizzly Industrial, Inc. warrants every product it sells for a period of **1 year** to the original purchaser from the date of purchase. This warranty does not apply to defects due directly or indirectly to misuse, abuse, negligence, accidents, repairs or alterations or lack of maintenance. This is Grizzly's sole written warranty and any and all warranties that may be implied by law, including any merchantability or fitness, for any particular purpose, are hereby limited to the duration of this written warranty. We do not warrant or represent that the merchandise complies with the provisions of any law or acts unless the manufacturer so warrants. In no event shall Grizzly's liability under this warranty exceed the purchase price paid for the product and any legal actions brought against Grizzly shall be tried in the State of Washington, County of Whatcom.

We shall in no event be liable for death, injuries to persons or property or for incidental, contingent, special, or consequential damages arising from the use of our products.

To take advantage of this warranty, contact us by mail or phone and give us all the details. We will then issue you a "Return Authorization Number," which must be clearly posted on the outside as well as the inside of the carton. We will not accept any item back without this number. Proof of purchase must accompany the merchandise.

The manufacturers reserve the right to change specifications at any time because they constantly strive to achieve better quality equipment. We make every effort to ensure that our products meet high quality and durability standards and we hope you never need to use this warranty.

Please feel free to write or call us if you have any questions about the machine or the manual.

Grizzly Industrial, Inc.
1203 Lycoming Mall Circle
Muncy, PA 17756
Phone: (570) 546-9663
Fax: (800) 438-5901

E-Mail:
techsupport@grizzly.com

Web Site: <http://www.grizzly.com>

Thank you again for your business and continued support. We hope to serve you again soon!

WARRANTY CARD

Name _____

Street _____

City _____ State _____ Zip _____

Phone Number _____ E-Mail _____ FAX _____

Model # _____ Order # _____

The following information is given on a voluntary basis. It will be used for marketing purposes to help us develop better products and services. Of course, all information is strictly confidential.

- How did you learn about us?
 Advertisement Friend
 Catalog Card Deck
 World Wide Web
 Other _____
- What is your annual household income?
 \$20,000-\$29,999 \$60,000-\$69,999
 \$30,000-\$39,999 \$70,000-\$79,999
 \$40,000-\$49,999 \$80,000-\$89,999
 \$50,000-\$59,999 \$90,000 +
- What is your age group?
 20-29 50-59
 30-39 60-69
 40-49 70 +
- How long have you been a woodworker?
 0 - 2 Years 8 - 20 Years
 2 - 8 Years 20+ Years
- How would you rank your woodworking skills?
 Simple Advanced
 Intermediate Master Craftsman
- What stationary woodworking tools do you own?
Check all that apply.
 Air Compressor Panel Saw
 Band Saw Planer
 Drill Press Power Feeder
 Drum Sander Radial Arm Saw
 Dust Collector Shaper
 Spindle Sander Jointer
 Table Saw Lathe
 Mortiser Wide Belt Sander
 Horiz.Boring Machine
 Vacuum Veneer Press
 Other _____
- How many of your woodworking machines are Grizzly? _____
- Which benchtop tools do you own? Check all that apply.
 1"x42" Belt Sander 6" - 8" Grinder
 5" - 8" Drill Press Mini Lathe
 8" Table Saw 8" - 10" Bandsaw
 Scroll Saw Disc/Belt Sander
 Spindle/Belt Sander Mini Jointer
 10"-12" Thickness Planer
 Other _____
- How many of the machines checked above are Grizzly? _____
- Which portable/hand held power tools do you own? Check all that apply.
 Belt Sander Orbital Sander
 Biscuit Joiner Palm Sander
 Circular Saw Portable Planer
 Detail Sander Saber Saw
 Drill/Driver Reciprocating Saw
 Miter Saw Router
 Other _____
- What machines/supplies would you like Grizzly Industrial to carry?

- What new accessories would you like Grizzly Industrial to carry?

- What other companies do you purchase your tools and supplies from?

- Do you think your purchase represents good value?
 Yes No
- Would you recommend Grizzly to a friend?
 Yes No
- Would you allow us to use your name as a reference for Grizzly customers in your area? **Note: We never use names more than three times.**
 Yes No
- Comments: _____

Send a Grizzly Catalog to a friend:

Name_____
Street_____
City_____State_____Zip_____

FOLD ALONG DOTTED LINE

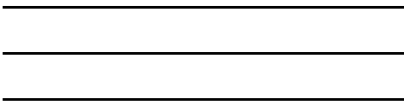

Place
Stamp
Here



GRIZZLY INDUSTRIAL, INC.
P.O. BOX 2069
BELLINGHAM, WA 98227-2069



TAPE ALONG EDGES--PLEASE DO NOT STAPLE