

F²MC-16FX FAMILY ADAPTER BOARD ADA-16FX-ETHERNET

USER GUIDE

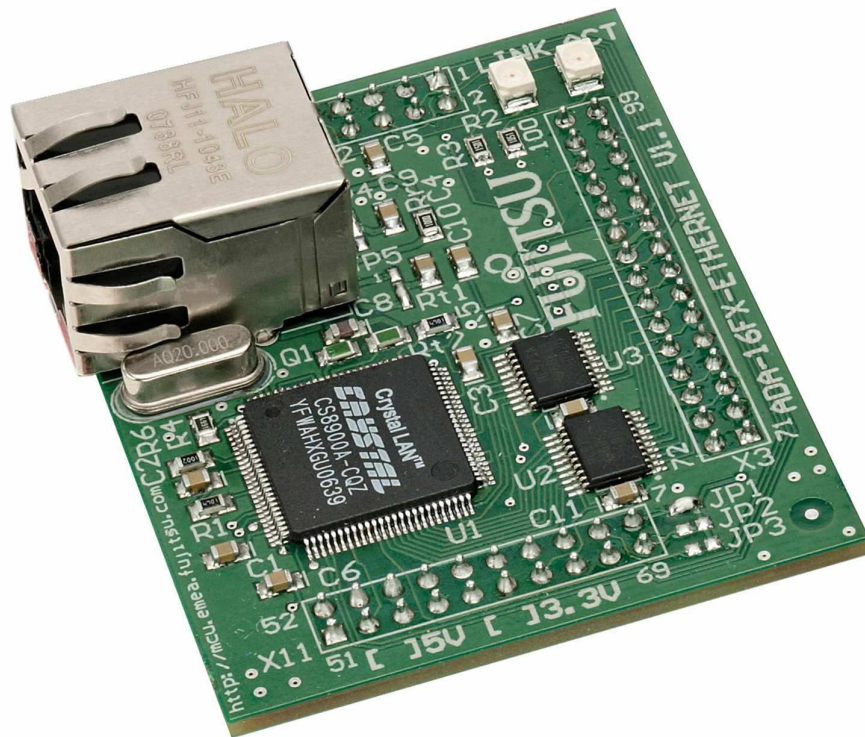

Revision History

Date	Issue
11.01.2008	V1.0, TKi, First Release
04.09.2008	V1.1, MSc, China-RoHS regulation added

This document contains 17 pages.

Warranty and Disclaimer

To the maximum extent permitted by applicable law, Fujitsu Microelectronics Europe GmbH restricts its warranties and its liability for **the ADA-16FX-ETHERNET Board and all its deliverables** (eg. software include or header files, application examples, target boards, evaluation boards, engineering samples of IC's etc.), its performance and any consequential damages, on the use of the Product in accordance with (i) the terms of the License Agreement and the Sale and Purchase Agreement under which agreements the Product has been delivered, (ii) the technical descriptions and (iii) all accompanying written materials. In addition, to the maximum extent permitted by applicable law, Fujitsu Microelectronics Europe GmbH disclaims all warranties and liabilities for the performance of the Product and any consequential damages in cases of unauthorised decompiling and/or reverse engineering and/or disassembling. **Note, the ADA-16FX-ETHERNET Board and all its deliverables are intended and must only be used in an evaluation laboratory environment.**

1. Fujitsu Microelectronics Europe GmbH warrants that the Product will perform substantially in accordance with the accompanying written materials for a period of 90 days from the date of receipt by the customer. Concerning the hardware components of the Product, Fujitsu Microelectronics Europe GmbH warrants that the Product will be free from defects in material and workmanship under use and service as specified in the accompanying written materials for a duration of 1 year from the date of receipt by the customer.
2. Should a Product turn out to be defect, Fujitsu Microelectronics Europe GmbH's entire liability and the customer's exclusive remedy shall be, at Fujitsu Microelectronics Europe GmbH's sole discretion, either return of the purchase price and the license fee, or replacement of the Product or parts thereof, if the Product is returned to Fujitsu Microelectronics Europe GmbH in original packing and without further defects resulting from the customer's use or the transport. However, this warranty is excluded if the defect has resulted from an accident not attributable to Fujitsu Microelectronics Europe GmbH, or abuse or misapplication attributable to the customer or any other third party not relating to Fujitsu Microelectronics Europe GmbH.
3. To the maximum extent permitted by applicable law Fujitsu Microelectronics Europe GmbH disclaims all other warranties, whether expressed or implied, in particular, but not limited to, warranties of merchantability and fitness for a particular purpose for which the Product is not designated.
4. To the maximum extent permitted by applicable law, Fujitsu Microelectronics Europe GmbH's and its supplier's liability are restricted to intention and gross negligence.

NO LIABILITY FOR CONSEQUENTIAL DAMAGES

To the maximum extent permitted by applicable law, in no event shall Fujitsu Microelectronics Europe GmbH and its suppliers be liable for any damages whatsoever (including but without limitation, consequential and/or indirect damages for personal injury, assets of substantial value, loss of profits, interruption of business operation, loss of information, or any other monetary or pecuniary loss) arising from the use of the Product.

Should one of the above stipulations be or become invalid and/or unenforceable, the remaining stipulations shall stay in full effect

1 Contents

REVISION HISTORY	2
WARRANTY AND DISCLAIMER	3
1 CONTENTS.....	4
2 OVERVIEW.....	5
2.1 Abstract.....	5
2.2 Features of adapter board ADA-16FX-ETHERNET	5
2.3 Features of base board SK-16FX-EUROSCOPE (SK-16FX-100PMC).....	5
3 INSTALLATION	6
3.1 Jumper settings of ADA-16FX-ETHERNET	7
4 JUMPERS AND LED'S.....	8
4.1 Chip select (JP: 1, 2, 3)	8
4.2 Ethernet jack select (JP: 4, 5).....	8
4.3 Link LED, Activity LED (LINK, ACT)	9
5 CONNECTORS.....	10
5.1 Ethernet connector (X1)	10
5.2 Edge Connectors (X2, X3, X11)	10
6 SILK-PLOT OF THE BOARD	11
7 RELATED PRODUCTS	12
8 INFORMATION IN THE WWW.....	13
9 CHINA-ROHS REGULATION	15
10 RECYCLING	17

2 Overview

2.1 Abstract

The ADA-16FX-ETHERNET is an adapter board that can be used together with the evaluation board SK-16FX-EUROSCOPE (SK-16FX-100PMC). The ADA-16FX-ETHERNET extends the evaluation board with Ethernet connectivity. It can be used for software development and testing.

The board allows the designer immediately to start with the software development before a final target system is available.

2.2 Features of adapter board ADA-16FX-ETHERNET

- ▶ 10BaseT Ethernet connectivity
 - Software example including openTCP stack is available
- ▶ Multiplexed bus interface
- ▶ Selectable chip select via Jumper
- ▶ Pin header for SK-16FX-EUROSCOPE (SK-16FX-100PMC) base board
(Note: SK-16FX-EUROSCOPE has to be ordered separately)

2.3 Features of base board SK-16FX-EUROSCOPE (SK-16FX-100PMC)

- ▶ 1x UART-Transceiver (SUB-D9 connector)
- ▶ 1x USB to serial converter (Type-B connector)
- ▶ 1x High-speed CAN-Transceiver (SUB-D9 connector)
- ▶ 2x LED-Display (7-Segment)
- ▶ 2x User-button
- ▶ 1x Reset-button, Reset-LED
- ▶ All 100 pins routed to pin-header
- ▶ On-board 5V and 3V voltage regulators, Power-LED
- ▶ USB power-supply (external power supply possible)

**This board must only be used for test applications
in an evaluation laboratory environment.**

3 Installation

Remove carefully the board from the shipping box and check for any damages.

Disconnect your SK-16FX-EUROSCOPE (SK-16FX-100PMC) evaluation board from USB and external power supply. Select the correct Voltage supply:

ADA-16FX-ETHERNET is designed for 5V power supply.

Jumper	Setting	Description
JP10 (5V/3V3)	1-2	VCC is set to 5V (ADA-16FX-ETHERNET)
	2-3	VCC is set to 3.3V

Attach the adapter board to the evaluation board as shown below. The Ethernet jack has to face to the outer edge.

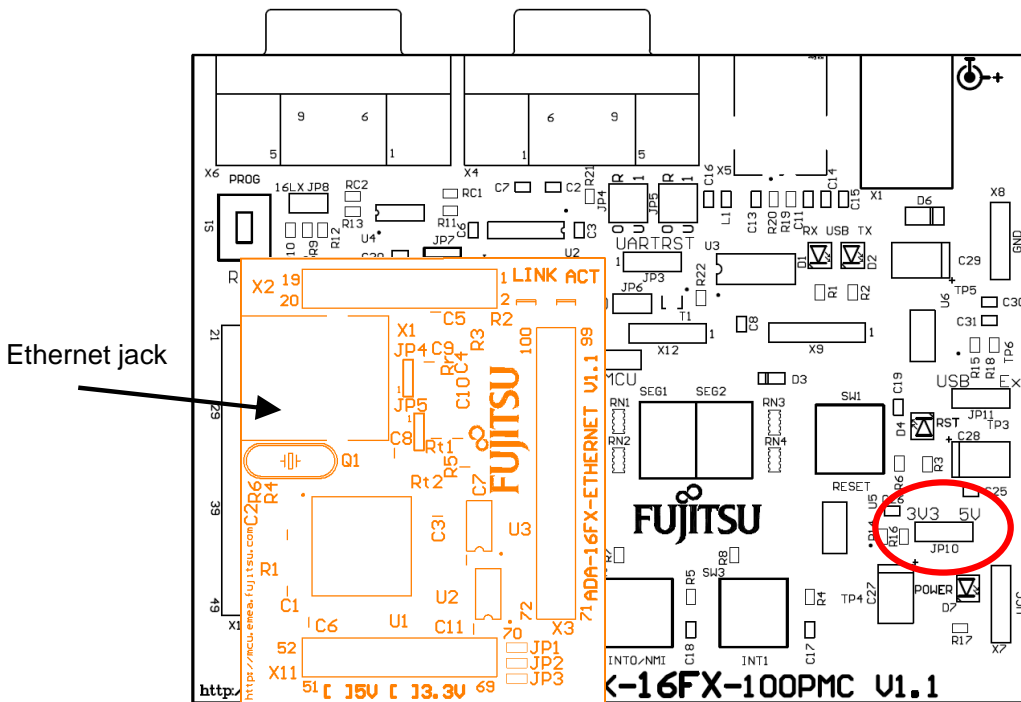

Note:

Make sure to jumper the board to 5V before connecting the ADA-16FX-ETHERNET.

3.1 Jumper settings of ADA-16FX-ETHERNET

The following jumper settings are set by default:

Jumper	Description / Function	Type	Default
JP1	Use chip select line 2	solder JP 2pol.	Closed
JP2	Use chip select line 3	solder JP 2pol.	Open
JP3	Use chip select line 4	solder JP 2pol.	Open
JP4	Select center tap A of Ethernet jack	solder JP 3pol.	1-2
JP5	Select center tap B of Ethernet jack	solder JP 3pol.	1-2

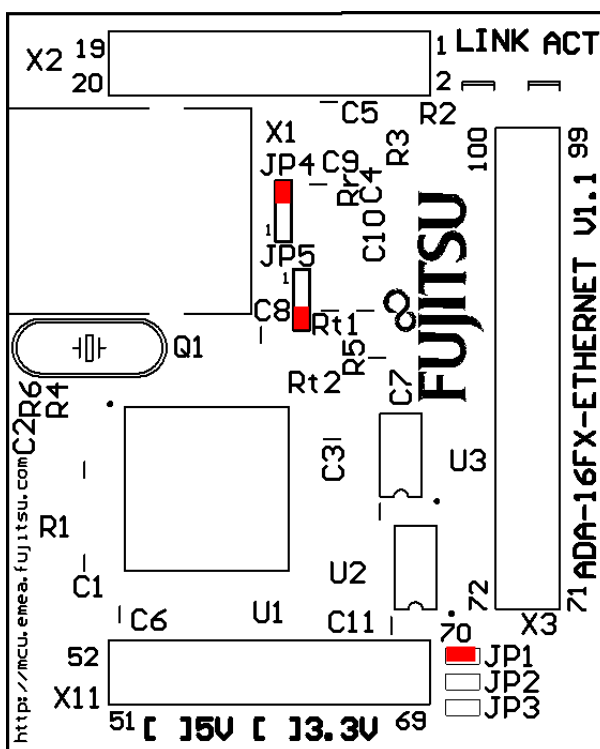

Please refer to the documentation of the evaluation board for detailed information about the jumper settings for the SK-16FX-EUROSCOPE (SK-16FX-100PMC).

4 Jumpers and LED's

This chapter describes all jumpers that can be modified and all LED's on the adapter board. The default setting is shown with a grey shaded area.

4.1 Chip select (JP: 1, 2, 3)

One out of the three chip select signals CS2, CS3 or CS4 can be selected:

JP1, JP2, JP3 connect chip select signal of MCU to chip select signal of Ethernet chip

Jumper	Setting	Description
JP1 (CS2)	ON (closed)	CS2 is connected to CHIPSEL of CS8900A
	OFF (open)	CS2 is not connected
JP2 (CS3)	ON (closed)	CS3 is connected to CHIPSEL of CS8900A
	OFF (open)	CS3 is not connected
JP3 (CS4)	ON (closed)	CS4 is connected to CHIPSEL of CS8900A
	OFF (open)	CS4 is not connected

Default: JP1 is closed

By default, the chip select signal CS2 of the MB96F348HS is connected to the Ethernet chip.

4.2 Ethernet jack select (JP: 4, 5)

The board layout is designed to be used with different Ethernet jacks.

JP4, JP5 Select center tap pin of Ethernet jack

Jumper	Setting	Description
JP4 (AVss)	1-2	Capacitor 9 is connected to pin 4 of the Ethernet jack
	2-3	Capacitor 9 is connected to pin 7 of the Ethernet jack
JP5 (AVcc)	1-2	Capacitor 10 is connected to pin 5 of the Ethernet jack
	2-3	Capacitor 10 is connected to pin 8 of the Ethernet jack

Default: JP4 and JP5 are set to 1-2

By default the pins 4 and 5 of the assembled Ethernet jack are used as center tap pin. This setting depends on the type and manufacturer of the used Ethernet jack (see chapter 5.1).

4.3 Link LED, Activity LED (LINK, ACT)

These LEDs display the status of the Ethernet interface.

LED	Colour	Description
LINK	Green	Indicates that a link is established
ACT	Yellow	Indicates activity on the Ethernet

By default the LINK LED should light directly after connected to a network.

5 Connectors

5.1 Ethernet connector (X1)

This is the Ethernet jack for connecting the ADA-16FX-ETHERNET to the Ethernet. The connector complies with the 10BaseT standard. The used connector has integrated transformers for transmit and receive lines.

The Ethernet jack and the Ethernet controller depends on the power supply voltage:

Supply Voltage	Used jack	Ethernet Chip	Adapter Board	Rx Transitions	Tx Transitions
5V	Halo HFJ11-1043E	CS8900CQZ	ADA-16FX-ETHERNET	1:1	1:1.41
3V3	Halo HFJ11-1041E	CS8900CQ3Z	-	1:1	1:2.5

5.2 Edge Connectors (X2, X3, X11)

The edge connectors are assembled on the bottom side of the adapter board. They are used to attach the ADA-16FX-ETHERNET adapter board to the SK-16FX-EUROSCOPE (SK-16FX-100PMC) evaluation board. All used signals are provided by the edge connectors.

Connector	MCU Pins
X2 (1 – 20)	1 – 20
X3 (71 – 100)	71 – 100
X11 (51 – 70)	51 – 70

The adapter board is powered via the edge connectors.

6 Silk-Plot of the Board

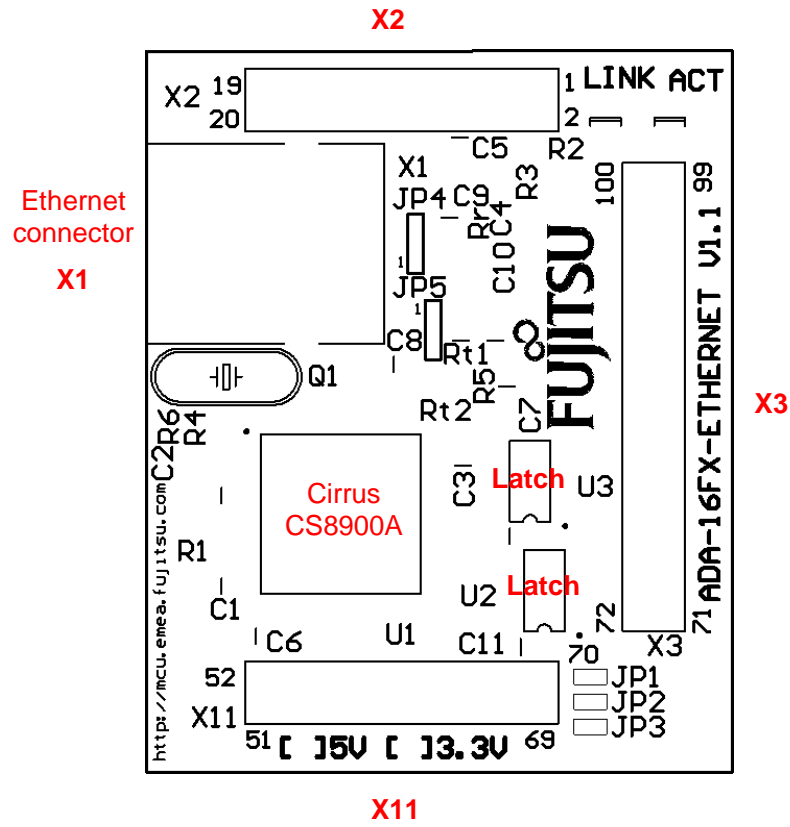

7 Related Products

- ▶ SK-16FX-EUROSCOPE Evaluation board with MB96F348HS
FPT-100P-M20 package
- ▶ ADA-16FX-ETHERNET Adapterboard for SK-16FX-EUROSCOPE
(SK-16FX-100PMC)
- ▶ MB96F348HS MB96340 Series Flash MCU

8 Information in the WWW

Information about FUJITSU MICROELECTRONICS Products can be found on the following Internet pages:

Microcontrollers (8-, 16-, and 32bit), Graphics Controllers
Datasheets and Hardware Manuals, Support Tools (Hard- and Software)

<http://mcu.emea.fujitsu.com>

Linear Products: Power Management, A/D and D/A Converters

<http://www.fujitsu.com/emea/services/microelectronics/linears/>

Media Products: SAW filters, acoustic resonators and VCOs

<http://www.fujitsu.com/emea/services/microelectronics/saw/>

For more information about FUJITSU MICROELECTRONICS

<http://www.fujitsu.com/emea/services/microelectronics/>

9 China-RoHS regulation

Evaluation Board 评估板

Emulation Board 仿真板

根据SJ/T11364-2006

《电子信息产品污染控制标识要求》特提供如下有关污染控制方面的信息。

The following product pollution control information is provided according to SJ/T11364-2006 *Marking for Control of Pollution caused by Electronic Information Products*.

1. 电子信息产品污染控制标志说明 Explanation of Pollution Control Label



该标志表明本产品含有超过中国标准SJ/T11363-2006

《电子信息产品中有毒有害物质的限量要求》中限量的有毒有害物质。标志中的数字为本产品的环保使用期，表明本产品在正常使用的条件下，有毒有害物质不会发生外泄或突变，用户使用本产品不会对环境造成严重污染或对其人身、财产造成严重损害的期限，单位为年。

为保证所声明的环保使用期限，应按产品手册中所规定的环境条件和方法进行正常使用，并严格遵守产品维修手册中规定的定期维修和保养要求。

产品中的消耗件和某些零部件可能有其单独的环保使用期限标志，并且其环保使用期限有可能比整个产品本身的环保使用期限短。应到期按产品维修程序更换那些消耗件和零部件，以保证所声明的整个产品的环保使用期限。

本产品在使用寿命结束时不可作为普通生活垃圾处理，应被单独收集妥善处理。

请注意：环保使用期限50年的指定不是与产品的耐久力，使用期限或任何担保要求等同的。

This symbol to be added to all EIO sold to China, indicates the product contains hazardous materials in excess of the limits established by the Chinese standard SJ/T11363-2006 *Requirements for Concentration Limits for Certain Hazardous Substances in Electronic Information Products*. The number in the symbol is the Environment-friendly Use Period (EFUP), which indicates the period, starting from the manufacturing date, during which the toxic or hazardous substances or elements contained in electronic information products will not leak or mutate under normal operating conditions so that the use of such electronic information products will not result in any severe environmental pollution, any bodily injury or damage to any assets, the unit of the period is "Year".

In order to maintain the declared EFUP, the product shall be operated normally according to the instructions and environmental conditions as defined in the product manual, and periodic maintenance schedules specified in Product Maintenance Procedures shall be followed strictly.

Consumables or certain parts may have their own label with an EFUP value less than the product. Periodic replacement of those consumables or parts to maintain the declared EFUP shall be done in accordance with the Product Maintenance Procedures.

This product must not be disposed of as unsorted municipal waste, and must be collected separately and handled properly after decommissioning.

Please note: The designation of 10 years EFUP is not to be equated with the durability, use-duration or any warranty-claims of the product.

产品中有毒有害物质或元素的名称及含量

Table of hazardous substances name and concentration

部件名称 Component Name	有毒有害物质或元素 Hazardous substances name					
	铅 (Pb)	汞 (Hg)	镉 (Cd)	六价铬 (Cr(VI))	多溴联苯 (PBB)	多溴二苯醚 (PBDE)
ADA-16FX-ETHERNET	x	o	o	o	o	o

O: 表示该有毒有害物质在该部件所有均质材料中的含量均在SJ/T11363-2006 标准规定的限量要求以下

X: 表示该有毒有害物质至少在该部件的某一均质材料中的含量超出SJ/T11363-2006 标准规定的限量要求

- 此表所列数据为发布时所能获得的最佳信息
- 由于缺少经济上或技术上合理可行的替代物质或方案，此医疗设备运用以上一些有毒有害物质来实现设备的预期临床功能，或给人员或环境提供更好的保护效果。

O: Indicates that this toxic or hazardous substance contained in all of the homogeneous materials for this part is below the limit requirement in SJ/T11363-2006.

X: Indicates that this toxic or hazardous substance contained in at least one of the homogeneous materials used for this part is above the limit requirement in SJ/T11363-2006.

- Data listed in the table represents best information available at the time of publication

10 Recycling

Gültig für EU-Länder:

Gemäß der Europäischen WEEE-Richtlinie und deren Umsetzung in landesspezifische Gesetze nehmen wir dieses Gerät wieder zurück.

Zur Entsorgung schicken Sie das Gerät bitte an die folgende Adresse:

Fujitsu Microelectronics Europe GmbH
Warehouse/Disposal
Monzastraße 4a
63225 Langen

Valid for European Union Countries:

According to the European WEEE-Directive and its implementation into national laws we take this device back.

For disposal please send the device to the following address:

Fujitsu Microelectronics Europe GmbH
Warehouse/Disposal
Monzastraße 4a
D-63225 Langen
Germany