

MODELS GRG15A-06G-7, GRG15A-06G-9, GRG15A-08G-7, GRG15M-06G-7, GRG15M-06G-9, GRG15M-08G-7, GRP15A-02P-7, GRS15A-04S-9, AND GRS15A-06S-7 1.5 H.P. ANGLE GRINDERS, POLISHERS, AND SANDERS

NOTICE

GRG Air Angle Grinders, GRS Air Angle Sanders and GRP Air Angle polishers are designed for smoothing, trimming or removing metal in close-quarter areas in foundries, shipyards, steel mills and in construction applications.

ARO is not responsible for customer modification of tools for applications on which ARO was not consulted.

WARNING

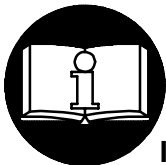

**IMPORTANT SAFETY INFORMATION ENCLOSED.
READ THIS MANUAL BEFORE OPERATING TOOL.**

**IT IS THE RESPONSIBILITY OF THE EMPLOYER TO PLACE THE INFORMATION
IN THIS MANUAL INTO THE HANDS OF THE OPERATOR.**

FAILURE TO OBSERVE THE FOLLOWING WARNINGS COULD RESULT IN INJURY.

PLACING TOOL IN SERVICE

- Always operate, inspect and maintain this tool in accordance with American National Standards Institute Safety Code for Portable Air Tools (ANSI B186.1).
- For safety, top performance, and maximum durability of parts, operate this tool at 90 psig (6.2 bar/620 kPa) maximum air pressure at the inlet with 3/10" (10 mm) inside diameter air supply hose.
- Always turn off the air supply and disconnect the air supply hose before installing, removing or adjusting any accessory on this tool, or before performing any maintenance on this tool.
- Do not use damaged, frayed or deteriorated air hoses and fittings.
- Be sure all hoses and fittings are the correct size and are tightly secured. See Dwg. TPD905-1 for a typical piping arrangement.
- Always use clean, dry air at 90 psig (6.2 bar/620 kPa) maximum air pressure. Dust, corrosive fumes and/or excessive moisture can ruin the motor of an air tool.
- Do not lubricate tools with flammable or volatile liquids such as kerosene, diesel or jet fuel.
- Do not remove any labels. Replace any damaged label.

USING THE TOOL

- Always wear eye protection when operating or performing maintenance on this tool.
- Always wear hearing protection when operating this tool.
- Keep hands, loose clothing and long hair away from rotating end of tool.
- Anticipate and be alert for sudden changes in motion during start up and operation of any power tool.
- Keep body stance balanced and firm. Do not overreach when operating this tool. High reaction torques can occur at or below the recommended air pressure.
- Tool accessories may continue to rotate briefly after throttle is released.
- Air powered tools can vibrate in use. Vibration, repetitive motions or uncomfortable positions may be harmful to your hands and arms. Stop using any tool if discomfort, tingling feeling or pain occurs. Seek medical advice before resuming use.
- Use accessories recommended by ARO.
- Whenever the Angle Head is installed or repositioned, the Throttle Lever must be positioned so that reaction torque will not tend to retain the throttle in the "ON" position.
- This tool is not designed for working in explosive atmospheres.
- This tool is not insulated against electric shock.

NOTICE

The use of other than genuine ARO replacement parts may result in safety hazards, decreased tool performance, and increased maintenance, and may invalidate all warranties.

Repairs should be made only by authorized trained personnel. Consult your nearest ARO Tool Products Authorized Servicenter.

For parts and service information, contact your local ARO distributor, or the Customer Service Dept. of the Ingersoll-Rand Distribution Center, White House, TN at PH: (615) 672-0321, FAX: (615) 672-0801

ARO Tool Products

Ingersoll-Rand Company

1725 U.S. No. 1 North, PO Box 8000, Southern Pines, NC 28388-8000

©1999 INGERSOLL-RAND COMPANY PRINTED IN U.S.A

WARNING LABEL IDENTIFICATION

⚠ WARNING

FAILURE TO OBSERVE THE FOLLOWING WARNINGS COULD RESULT IN INJURY.

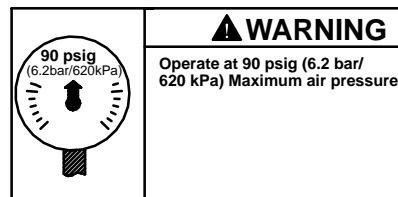
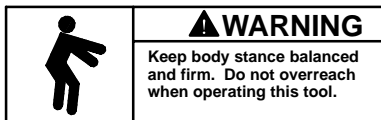
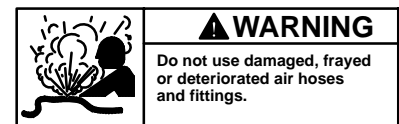
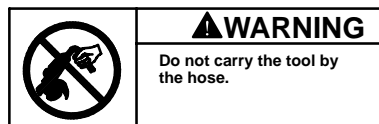
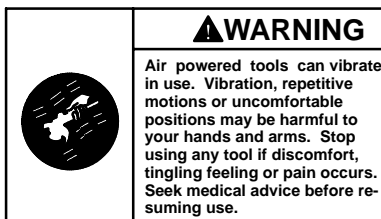
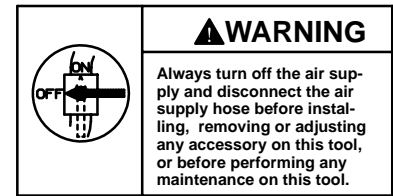
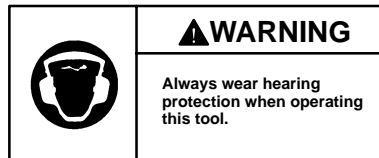
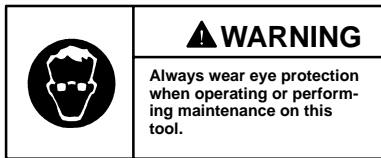

GRINDER SPECIFIC WARNINGS

⚠ WARNING

FAILURE TO OBSERVE THE FOLLOWING WARNINGS COULD RESULT IN INJURY.

- Do not use this tool if actual free speed exceeds the nameplate rpm.
- Before mounting a wheel, after any tool repair or whenever a Grinder is issued for use, check free speed of Grinder with a tachometer to make certain its actual speed at 90 psig (6.2 bar/620 kPa) does not exceed rpm stamped or printed on the nameplate. Grinders in use on the job must be similarly checked at least once each shift.
- Always use the recommended ARO Wheel Guard furnished with the Grinder.
- Do not use any grinding wheel, bur or other accessory having a maximum operating speed less than the free speed of the Grinder in which it is being used. Always conform to maximum rpm on grinding wheel blotters.
- Inspect all grinding wheels for chips or cracks prior to mounting. Do not use a wheel that is chipped or cracked or otherwise damaged. Do not use a wheel that has been soaked in water or any other liquid.
- Make certain grinding wheel properly fits the arbor. Do not use reducing bushings to adapt a wheel to any arbor unless such bushings are supplied by and recommended by the wheel manufacturer.
- After mounting a new wheel, hold the Grinder under a steel workbench or inside a casting and run it for at least 60 seconds. Make certain no one is within the operating plane of the grinding wheel. If a wheel is defective, improperly mounted or the wrong size and speed, this is the time it will usually fail.
- When starting with a cold wheel, apply it to the work slowly until the wheel gradually warms up. Make smooth contact with the work and avoid any bumping action or excessive pressure.
- Always replace a damaged, bent or severely worn wheel guard. Do not use a wheel guard that has been subjected to a wheel failure.
- Make certain wheel flanges are at least 1/3 the diameter of grinding wheel, free of nicks, burrs and sharp edges. Always use wheel flanges furnished by the manufacturer; never use a makeshift flange or a plain washer. Tighten Flange Nut securely.
- Guard opening must face away from operator. Bottom of wheel must not project beyond guard.
- Always match collet size with accessory shank size.
- Always insert tool shank no less than 10 mm in the collet. Tighten Collet Nut securely to prevent accessory from working out during operation of the Grinder. Check tightness of Collet Nut before operating the Grinder. Pay particular attention to the fact that allowed speed of a mounted point is lowered when the length of the shaft is increased between end of collet and mounted point (overhang).

SANDER/POLISHER SPECIFIC WARNINGS

- These Sanders and Polishers will operate at the free speed specified on the nameplate if the air supply line furnishes 90 psig (6.2 bar/620 kPa) air pressure at the tool. Operation at higher air pressure will result in excessive speed.
- Use only a sanding pad, buffing wheel or polishing bonnet with these tools. Do not use any grinding wheel, bur or metal removing accessory other than a sanding pad with these tools. Never use an

accessory having a maximum operating speed less than the free speed of the Sander or Polisher in which it is being used.

- When using a pad on a threaded arbor, make certain the flange nut is tightened securely. Check the tightness of the flange nut before operating a Sander to make certain it will not loosen during operation.

WARNING: Incorrect combinations of grinding wheel, wheel guard and tool speed could result in injury. Correct combinations are specified below:

Guard Part Number	Wheel Type	Wheel Diameter in. (mm)	Maximum Wheel Thickness in. (mm)	Maximum Speed rpm
77A-106-7	27, 28	7 (178)	1/4 (6.4)	7,500
77A-106-9	27, 28	7 (178)	1/4 (6.4)	6,000

PLACING TOOL IN SERVICE

LUBRICATION



IRAX No. 50P



IRAX No. 68 1LB

Always use an air line lubricator with these tools. We recommend the following Filter-Lubricator-Regulator Unit:

For USA – No. C18-03-FKG0-28

Before starting the tool, unless the air line lubricator is used, detach the air hose and inject about 2.5 cc of IRAX No. 50P Oil into the air inlet.

After each eight hours of operation, replenish the oil supply. Remove the Oil Chamber Plug (7) from the Throttle Handle (1) and fill the chamber.

After each forty-eight hours of operation, inject about 5 cc of IRAX No. 68 1LB Grease into each Grease Fitting (44).

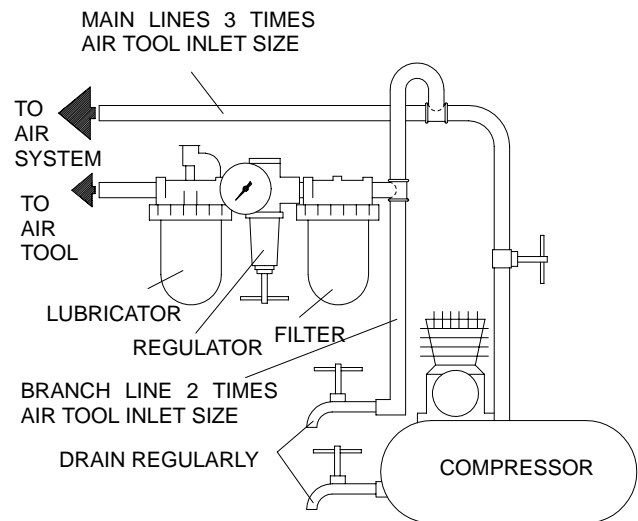

(Dwg. TPD905-1)

HOW TO ORDER A GRINDER

ANGLE GRINDERS with DEPRESSED CENTER WHEELS

Model	Free Speed, rpm	Type 27 and 28 Wheel		Spindle and Guard
		inches	mm	
GRG15A-06G-7	6,000	7	178	5/8-11, 7"
GRG15A-06G-9	6,000	9	227	5/8-11, 9"
GRG15A-08G-7	7,500	7	178	5/8-11, 7"
GRG15M-06G-7	6,000	7	178	5/8-11, 7"
GRG15M-06G-9	6,000	9	227	5/8-11, 9"
GRG15M-08G-7	7,500	7	178	5/8-11, 7"

HOW TO ORDER A SANDER OR POLISHER

ANGLE SANDERS AND POLISHER

Model	Free Speed, rpm	Back up Pad		Spindle
		inches	mm	
GRP15A-02P-7	2,500	7	178	5/8-11, 7"
GRS15A-06S-7	6,000	7	178	5/8-11, 7"
GRS15A-04S-9	4,500	9	228	5/8-11, 9"

**MEULEUSES, PONCEUSES ET POLISSEUSES D'ANGLE
DES SÉRIES GRG15A-06G-7, GRG15A-06G-9,
GRG15A-08G-7, GRG15M-06G-7, GRG15M-06G-9, GRG15M-08G-7,
GRP15A-02P-7, GRS15A-04S-9 ET GRS15A-06S-7 1.5 H.P.****F****NOTE**

Les meuleuses, ponceuses et polisseuses d'angle des séries GRG, GRS et GRP sont destinées au ponçage, à l'ébavurage ou à l'enlèvement du métal dans les fonderies, les chantiers navals, les aciéries et la construction.

ARO ne peut être tenu responsable de la modification des outils par le client pour les adapter à des applications qui n'ont pas été approuvées par ARO.

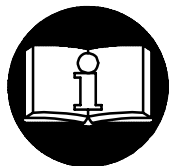
⚠ ATTENTION

**D'IMPORTANTES INFORMATIONS DE SÉCURITÉ SONT JOINTES.
LIRE CE MANUEL AVANT D'UTILISER L'OUTIL.
L'EMPLOYEUR EST TENU DE COMMUNIQUER LES INFORMATIONS
DE CE MANUEL AUX EMPLOYÉS UTILISANT CET OUTIL.**

LE NON RESPECT DES AVERTISSEMENTS SUIVANTS PEUT CAUSER DES BLESSURES.

MISE EN SERVICE DE L'OUTIL

- Toujours exploiter, inspecter et entretenir cet outil conformément au Code de sécurité des outils pneumatiques portatifs de l'American National Standards Institute (ANSI B186.1).
 - Pour la sécurité, les performances optimales et la durabilité maximale des pièces, cet outil doit être connecté à une alimentation d'air comprimé de 6,2 bar (620 kPa) maximum à l'entrée, avec un flexible de 10 mm de diamètre intérieur.
 - Couper toujours l'alimentation d'air comprimé et débrancher le flexible d'alimentation avant d'installer, déposer ou ajuster tout accessoire sur cet outil, ou d'entreprendre une opération d'entretien quelconque sur l'outil.
 - Ne pas utiliser des flexibles ou des raccords endommagés, effilochés ou détériorés.
 - S'assurer que tous les flexibles et les raccords sont correctement dimensionnés et bien serrés. Voir Plan TPD905-1 pour un exemple type d'agencement des tuyauteries.
 - Utiliser toujours de l'air sec et propre à une pression maximum de 6,2 bar (620 kPa). La poussière, les fumées corrosives et/ou une humidité excessive peuvent endommager le moteur d'un outil pneumatique.
 - Ne jamais lubrifier les outils avec des liquides inflammables ou volatils tels que le kérosène, le gasol ou le carburant d'aviation.
 - Ne retirer aucune étiquette. Remplacer toute étiquette endommagée.
- Porter toujours une protection acoustique pendant l'utilisation de cet outil.
 - Tenir les mains, les vêtements flous et les cheveux longs, éloignés de l'extrémité rotative de l'outil.
 - Prévoir, et ne pas oublier, que tout outil motorisé est susceptible d'à-coups brusques lors de sa mise en marche et pendant son utilisation.
 - Garder une position équilibrée et ferme. Ne pas se pencher trop en avant pendant l'utilisation de cet outil. Des couples de réaction élevés peuvent se produire à, ou en dessous, de la pression d'air recommandée.
 - La rotation des accessoires de l'outil peut continuer pendant un certain temps après le relâchement de la gâchette.
 - Les outils pneumatiques peuvent vibrer pendant l'exploitation. Les vibrations, les mouvements répétitifs et les positions inconfortables peuvent causer des douleurs dans les mains et les bras. N'utiliser plus d'outils en cas d'inconfort, de picotements ou de douleurs. Consulter un médecin avant de recommencer à utiliser l'outil.
 - Utiliser les accessoires recommandés par ARO.
 - A chaque fois que le renvoi d'angle est installé ou repositionné, le levier de commande doit être positionné de manière à ce que le couple de réaction n'ait pas tendance à maintenir le levier de commande en position "MARCHE".
 - Cet outil n'est pas conçu pour fonctionner dans des atmosphères explosives.
 - Cet outil n'est pas isolé contre les chocs électriques.

UTILISATION DE L'OUTIL

- Porter toujours des lunettes de protection pendant l'utilisation et l'entretien de cet outil.

NOTE

L'utilisation de rechanges autres que les pièces d'origine ARO peut causer des risques d'insécurité, réduire les performances de l'outil et augmenter l'entretien, et peut annuler toutes les garanties.

Les réparations ne doivent être effectuées que par des réparateurs qualifiés autorisés. Consultez votre Centre de Service ARO Tool Products le plus proche.

Pour les informations relatives aux pièces et au service, contactez votre distributeur ARO.

ARO Tool Products**Ingersoll-Rand Company**

1725 U.S. No. 1 North, PO Box 8000, Southern Pines, NC 28388-8000

©1999 INGERSOLL-RAND COMPANY Imprimé aux E.U.

SIGNIFICATION DES ÉTIQUETTES D'AVERTISSEMENT

⚠ ATTENTION

LE NON RESPECT DES AVERTISSEMENTS SUIVANTS PEUT CAUSER DES BLESSURES

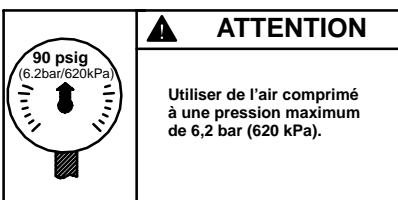
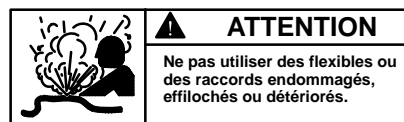
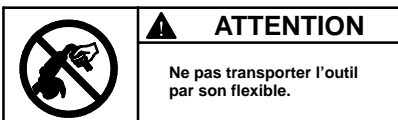
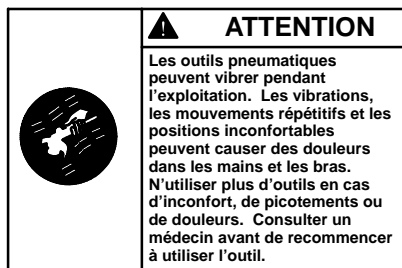
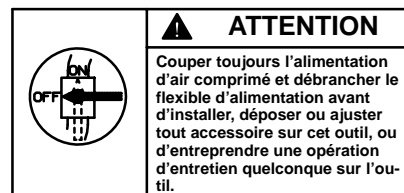
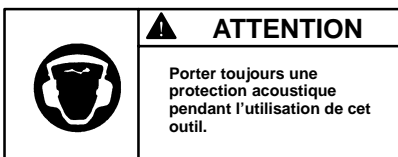
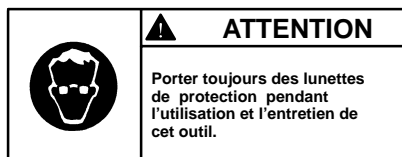

AVERTISSEMENTS SPÉCIFIQUES AUX MEULEUSES

⚠ ATTENTION

LE NON RESPECT DES AVERTISSEMENTS SUIVANTS PEUT CAUSER DES BLESSURES.

- Ne pas utiliser cet outil si la vitesse à vide réelle dépasse celle indiquée sur la plaque signalétique.
- Avant de monter une meule, après toute réparation de l'outil ou avant de fournir une meuleuse pour utilisation, vérifier la vitesse à vide de la meuleuse avec un tachymètre pour s'assurer que la vitesse réelle à 6,2 bar (620 kPa) ne dépasse pas celle poinçonnée ou imprimée sur la plaque signalétique. Les meuleuses sorties sur chantier doivent être vérifiées de la même façon au moins une fois par poste.
- Utiliser toujours le protège-meule ARO fourni avec la meuleuse.
- Ne jamais utiliser une meule, une fraise ou tout autre accessoire ayant une vitesse de service inférieure à la vitesse à vide de la meuleuse sur laquelle il est monté. Respecter toujours la vitesse maximum inscrite sur les disques en papier de la meule.
- Inspecter toutes les meules avant de les monter pour vérifier qu'elles ne présentent pas d'éclats ou de fissures. Ne jamais utiliser une meule écaillée, fissurée ou ayant un endommagement quelconque. Ne jamais utiliser une meule qui a été trempée dans l'eau ou tout autre liquide.
- S'assurer que la meule se monte correctement sur l'arbre. Ne pas utiliser de bagues réductrices, à moins que ces bagues soient recommandées et fournies par le fabricant de la meule.
- Après avoir monté une nouvelle meule, tenir la meuleuse sous un établi en acier ou dans une pièce coulée et la faire tourner pendant au moins 60 secondes. S'assurer que personne ne se tient dans le plan de rotation de la meule. Toute meule défectueuse, mal montée ou de dimension et vitesse incorrectes se cassera généralement à ce moment là.
- Pour commencer le travail avec une meule froide, l'appliquer lentement contre la pièce jusqu'à ce que la meule s'échauffe progressivement. Mettre la meule en contact avec la pièce en douceur en évitant tout choc ou pression excessive.
- Remplacer toujours un protège-meule endommagé, tordu ou très usé. Ne pas utiliser un protège-meule qui a été soumis à la rupture d'une meule.
- S'assurer que les flasques de meule couvrent au moins 1/3 du diamètre de la meule, et qu'ils sont exempts d'entailles, de bavures et d'arêtes vives. Utiliser toujours les flasques fournis par le fabricant; ne jamais utiliser de flasque de provenance douteuse ou de rondelle plate. Serrer fermement l'écrou du flasque.
- L'ouverture du protège-meule doit être orientée côté opposé à l'opérateur. Le bas de la meule ne doit pas dépasser le protège-meule.
- Toujours choisir une pince adaptée à la dimension de la queue de l'accessoire.
- La queue de l'outil doit toujours être insérée dans la pince sur au moins 10 mm. Serrer fermement l'écrou de pince pour éviter tout desserrage de l'accessoire pendant l'emploi de la meuleuse. Vérifier le serrage de l'écrou de pince avant de mettre la meuleuse en marche. Ne jamais oublier que la vitesse admissible d'une meule sur tige doit être réduite lorsque la longueur de la tige entre le bout de la pince et la meule (porte-à-faux) est augmentée.

AVERTISSEMENTS PARTICULIERS AUX PONCEUSES/POLISSEUSES

- Ces ponceuses et polisseuses fonctionneront à la vitesse à vide spécifiée sur la plaque signalétique lorsque le circuit d'alimentation fournit de l'air à une pression de 6,2 bar (620 kPa) à l'outil. L'exploitation à une pression supérieure produira une vitesse excessive.
- Utiliser seulement un plateau de ponçage, un disque

de polissage ou une peau de mouton de polissage avec ces outils. Ne jamais utiliser de meule ou d'accessoire d'ébavurage ou d'enlèvement de métal autre que le plateau de ponçage sur ces outils. Ne jamais utiliser un accessoire ayant une vitesse de fonctionnement maximum inférieure à la vitesse à vide de la ponceuse ou de la polisseuse sur laquelle il est utilisé.

ATTENTION: Une mauvaise combinaison de roue d'affûtage, de protection de roue et de vitesse de l'outil peut provoquer un accident corporel. Les combinaisons correctes sont spécifiées ci-dessous:

Référence de la protection	Type de roue	Diamètre de roue mm (po.)	Epaissereu maximale de roue mm (po.)	Vitesse maximale (t/min)
77A-106-7	27, 28	7 (178)	1/4 (6,4)	7.500
77A-106-9	27, 28	7 (178)	1/4 (6,4)	6.000

MISE EN SERVICE DE L'OUTIL

LUBRIFICATION



IRAX No. 50P



IRAX No. 67 1LB

Utiliser toujours un lubrificateur avec ces outils. Nous recommandons l'emploi du filtre-régulateur-lubrificateur suivant :

For USA – N°. C18-03-FKG0-28

Avant de mettre l'outil en marche, si un lubrificateur de ligne n'est pas utilisé, débrancher le flexible d'alimentation et verser environ 2,5 cm³ IRAX No. 50P d'huile dans le raccord d'admission de l'outil.

Toutes les huit heures de fonctionnement, remplir la réserve d'huile. Déposer le bouchon de la chambre d'huile de la poignée de commande et remplir la chambre d'huile.

Toutes les quarante-huit heures de fonctionnement, injecter environ 5 cm³ IRAX No. 68 1LB de graisse dans chaque raccord de graissage.

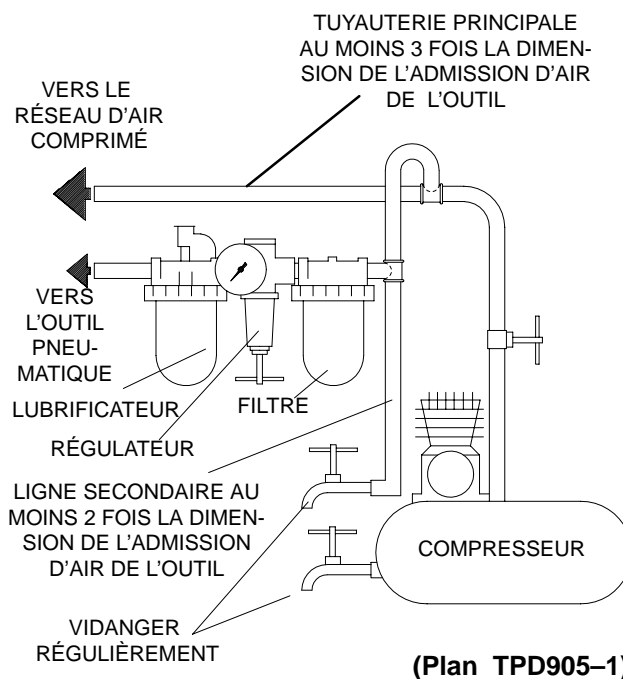

MISE EN SERVICE DE L'OUTIL

SPÉCIFICATIONS

Modèle	Vitesse à vide	Meules Types 27 et 28		Arbre et protégé-meule
		tr/mn	pouces	
GRG15A-06G-7	6.000	7	178	5/8-11, 7"
GRG15A-06G-9	6.000	9	227	5/8-11, 9"
GRG15A-08G-7	7.500	7	178	5/8-11, 7"
GRG15M-06G-7	6.000	7	178	5/8-11, 7"
GRG15M-06G-9	6.000	9	227	5/8-11, 9"
GRG15M-08G-7	7.500	7	178	5/8-11, 7"
Modèle	Vitesse à vide	Plateau-support		Broche
		tr/mn	pouces	
GRP15A-02P-7	2.500	7	178	5/8-11, 7"
GRS15A-06S-7	6.000	7	178	5/8-11, 7"
GRS15A-04S-9	4.500	9	228	5/8-11, 9"

LIJADORAS Y PULIDORAS, AMOLADORAS

E

ANGULARES DE LAS SERIES GRG15A-06G-7, GRG15A-06G-9, GRG15A-08G-7, GRG15M-06G-7, GRG15M-06G-9, GRG15M-08G-7, GRP15A-02P-7, GRS15A-04S-9 Y GRS15A-06S-7 1.5 H.P.

NOTA

Las Lijadoras y Pulidoras, Amoladoras Angulares Neumáticas de las Series GRG, GRS y GRP están diseñadas para pulido, recorte o eliminación de metal en fundiciones, astilleros, fábricas de acero y en la industria de construcción.

ARO no aceptará responsabilidad alguna por la modificación de las herramientas efectuada por el cliente para las aplicaciones que no hayan sido consultadas con ARO.

⚠ AVISO



SE ADJUNTA INFORMACIÓN IMPORTANTE DE SEGURIDAD. LEA ESTE MANUAL ANTES DE UTILIZAR LA HERRAMIENTA. ES RESPONSABILIDAD DE LA EMPRESA ASEGURARSE DE QUE EL OPERARIO ESTÉ AL TANTO DE LA INFORMACIÓN QUE CONTIENE ESTE MANUAL. EL HACER CASO OMISO DE LOS AVISOS SIGUIENTES PODRÍA OCASIONAR LESIONES.

PARA PONER LA HERRAMIENTA EN SERVICIO

- Utilice, examine y mantenga siempre esta herramienta conforme al código de seguridad para herramientas neumáticas portátiles de la American National Standards Institute (ANSI B186.1).
- Para mayor seguridad, rendimiento óptimo y larga vida útil de las piezas, utilice esta herramienta a una presión de aire máxima de 90 psig (6,2 bar/620 kPa) con una manguera de suministro de aire con diámetro interno de 10 mm.
- Corte siempre el suministro de aire y desconecte la manguera de suministro de aire antes de instalar, desmontar o ajustar cualquier accesorio de esta herramienta, o antes de realizar cualquier operación de mantenimiento de la misma.
- No utilice mangueras de aire y racores dañados, desgastados o deteriorados.
- Asegúrese de que todos los racores y mangueras sean del tamaño correcto y estén bien apretados. El Esq. TPD905-1 muestra una disposición característica de las tuberías.
- Use siempre aire limpio y seco a una presión máxima de 90 psig (6,2 bar/620 kPa). El polvo, los gases corrosivos y el exceso de humedad pueden estropear el motor de una herramienta neumática.
- No lubrique las herramientas con líquidos inflamables o volátiles tales como queroseno, gasoil o combustible para motores a reacción.
- No saque ninguna etiqueta. Sustituya toda etiqueta dañada.

UTILIZACIÓN DE LA HERRAMIENTA

- Use siempre protección ocular cuando utilice esta herramienta o realice operaciones de mantenimiento en la misma.
- Use siempre protección para los oídos cuando utilice esta herramienta.
- Mantenga las manos, la ropa suelta y el cabello largo alejados del extremo giratorio de la herramienta.
- Anticipe y esté atento a los cambios repentinos en el movimiento durante la puesta en marcha y utilización de toda herramienta motorizada.
- Mantenga una postura del cuerpo equilibrada y firme. No estire demasiado los brazos al manejar la herramienta. Pueden darse elevados pares de reacción a la presión de aire recomendada, e incluso a presiones inferiores.
- Los accesorios de la herramienta podrían seguir girando brevemente después de haberse soltado la palanca de mando.
- Las herramientas neumáticas pueden vibrar durante el uso. La vibración, los movimientos repetitivos o las posiciones incómodas pueden dañarle los brazos y manos. En caso de incomodidad, sensación de hormigueo o dolor, deje de usar la herramienta. Consulte con el médico antes de volver a utilizarla.
- Utilice únicamente los accesorios ARO recomendados.
- Cuando se instale o reposicione la cabeza angular, la palanca de mando deberá colocarse de forma que la reacción de par no tienda a retener el mando en la posición de "ON" (ACCIONAMIENTO).
- Esta herramienta no ha sido diseñada para trabajar en ambientes explosivos.
- Esta herramienta no está aislada contra descargas eléctricas.

NOTA

El uso de piezas de recambio que no sean las auténticas piezas ARO puede poner en peligro la seguridad, reducir el rendimiento de la herramienta y aumentar los cuidados de mantenimiento necesarios, así como invalidar toda garantía.

Las reparaciones sólo se deben encomendar a personal debidamente cualificado y autorizado. Consulte con el centro de servicio autorizado ARO Tool Products más próximo.

Pour les informations relatives aux pièces et au service, contactez votre distributeur ARO.

ARO Tool Products

Ingersoll-Rand Company

1725 U.S. No. 1 North, PO Box 8000, Southern Pines, NC 28388-8000

©1999 INGERSOLL-RAND COMPANY Impreso en EE.UU.

ETIQUETAS DE AVISO

⚠ AVISO

EL HACER CASO OMISO DE LOS AVISOS SIGUIENTES PODRÍA OCASIONAR LESIONES.

	⚠ ADVERTENCIA Use siempre protección ocular cuando utilice esta herramienta o realice operaciones de mantenimiento en la misma.
---	---

	⚠ ADVERTENCIA Use siempre protección para los oídos cuando utilice esta herramienta.
---	--

	⚠ ADVERTENCIA Cortar siempre el suministro de aire y desconectar la manguera de suministro de aire antes de instalar, retirar o ajustar cualquier accesorio de esta herramienta, o antes de realizar cualquier operación de mantenimiento de la misma.
---	--

	⚠ ADVERTENCIA Las herramientas neumáticas pueden vibrar durante el uso. La vibración, los movimientos repetitivos o las posiciones incómodas podrían dañarle los brazos y las manos. En caso de incomodidad, sensación de hormigueo o dolor, dejar de usar la herramienta. Consultar al médico antes de volver a utilizarla.
---	--

	⚠ ADVERTENCIA No coger la herramienta por la manguera para levantarla.
---	--

	⚠ ADVERTENCIA No utilizar mangueras de aire y accesorios dañados, desgastados ni deteriorados.
---	--

	⚠ ADVERTENCIA Mantener una postura del cuerpo equilibrada y firme. No estirar demasiado los brazos al manejar la herramienta.
---	---

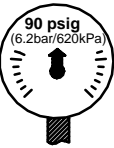
	⚠ ADVERTENCIA Manejar la herramienta a una presión de aire máxima de 90 psig (6,2 bar/620 kPa).
---	---

AVISOS ESPECÍFICOS SOBRE LAS AMOLADORAS

⚠ AVISO

EL HACER CASO OMISO DE LOS AVISOS SIGUIENTES PODRÍA OCASIONAR LESIONES.

- No utilice esta herramienta si la velocidad en vacío real supera la velocidad que indica la placa de identificación.
- Antes de montar una muela, después de haberse reparado la herramienta o cuando se proporciona una amoladora para su uso, compruebe la velocidad en vacío de la amoladora con un tacómetro para asegurarse de que su velocidad real a 90 psig (6,2 bar/620 kPa) no exceda de la velocidad estampada o impresa en la placa de identificación. Las amoladoras que ya están en uso también se deben examinar como mínimo una vez en cada turno de trabajo.
- Utilice siempre el cubremuela ARO recomendado y suministrado con la amoladora.
- No utilice nunca una muela abrasiva, fresa u otro accesorio cuya velocidad máxima de funcionamiento sea inferior a la velocidad en vacío de la amoladora en la que se va a utilizar. Observe siempre la velocidad máxima indicada en la arandela de sujeción de la muela.
- Inspeccione todas las muelas antes de montarlas para comprobar que no tengan muescas ni grietas. No utilice una muela que presente muescas, grietas o daño alguno. No utilice una muela que haya estado en remojo en agua o en cualquier otro líquido.
- Asegúrese de que la muela quede bien ajustada en el eje. No utilice casquillos reductores para adaptar una muela al eje, salvo que éstos hayan sido suministrados y recomendados por el fabricante de la muela.
- Después de haber montado una muela nueva, sujete la amoladora debajo de un banco de acero o dentro de una pieza de fundición y hágala girar durante 60 segundos como mínimo. Asegúrese de que no haya nadie en el entorno de operación de la muela. Si la muela es defectuosa, está mal montada o es del tamaño y velocidad incorrectas, normalmente fallará en este momento.
- Cuando ponga en marcha una muela en frío, aplíquela lentamente al trabajo para que se caliente gradualmente. Haga contacto suavemente con la pieza a trabajar y evite los rebotes o el exceso de presión.
- Cambie siempre un cubremuela dañado, torcido o muy desgastado. No utilice un cubremuela que haya estado en uso al romperse una muela.
- Asegúrese de que las bridas de la muela tengan un diámetro de al menos 1/3 del diámetro de la muela y que no tengan cortes, rebabas ni bordes afilados. Utilice siempre las bridas de muela suministradas por el fabricante; no use nunca una brida casera o arandela normal. Apriete bien la tuerca de la brida.

(continúa)

AVISOS ESPECÍFICOS SOBRE LAS AMOLADORAS

- La abertura del cubremuela debe estar orientada en sentido contrario al operario. La parte inferior de la muela no debe sobresalir del cubremuela.
- Utilice siempre la pinza cuyo tamaño corresponda con el tamaño del eje del accesorio.
- Introduzca siempre el eje de la herramienta en la pinza un mínimo de 10 mm. Apriete bien la tuerca de la pinza para evitar que se salga el accesorio

durante el funcionamiento de la amoladora. Compruebe el apriete de la tuerca de la pinza antes de accionar la amoladora. Preste especial atención al hecho de que la velocidad permitida de un accesorio montado disminuye cuando se incrementa la longitud del eje entre el extremo de la pinza y el accesorio.

AVISOS ESPECIFICOS DE LIJADORA/PULIDORA

- Estas Lijadoras y Pulidoras funcionarán a la velocidad constante especificada en la placa de identificación si la línea de suministro de aire a la herramienta tiene una presión de 90 psig (6,2bar/ 6,2 kPa). El funcionamiento a mayores presiones resultará en exceso de velocidad.
- Use sólo lija, placa de pulir o boina de pulir con estas herramientas. No use muela, ni accesorio escariador o fresador, que no sea para lijar con estas heramientas.

- No use nunca un accesorio que tenga una máxima velocidad de funcionamiento menor a la velocidad de la Lijadora o Pulidora en la que se va a usar.
- Use sólo lija, rueda de pulir o bonete de pulir con estas herramientas. No use muela, ni accesorio escariador o fresador, que no sea para lijar con estas herramientas. No use nunca un accesorio que tenga una máxima velocidad de funcionamiento menor a la velocidad de la Lijadora o Pulidora en la que se va a usar.

AVISO: Combinaciones incorrectas de rueda de rectificación, protector de rueda y velocidad de herramienta puedan resultar en lesionamientos. Las combinaciones correctas se especifican a continuación:

Número de Pieza del Protector	Tipo de Rueda	Diámetro de Rueda mm (in.)	Grosor Máximo de Rueda mm (in.)	Velocidad Máxima (rpm)
77A-106-7	27, 28	7 (178)	1/4 (6,4)	7.500
77A-106-9	27, 28	7 (178)	1/4 (6,4)	6.000

PARA PONER LA HERRAMIENTA EN SERVICIO

LUBRICACIÓN



IRAX N°. 10P

Utilice siempre un lubricador de aire comprimido con estas herramientas. Recomendamos el siguiente conjunto de filtro-lubricador-regulador:

USA – N°. C18-03-FKG0-28

Antes de pone la herramienta en marcha, a menos que se haya puesto lubricante de línea de aire comprimido, desconecte la manguera de aire e inyecte 2,5cc IRAX N° 10P de aceite en la admisión de aire.

Después de cada ocho horas de uso, reponga el suministro de aceite. Saque el Tapón de Cámara de Aceite de la Palanca de Estrangulador y llene la cámara.

Después de cada cuarenta y ocho horas de uso, inyecte así como 5 cc IRAX N°. 67 1LB de grasa en cada engrasador.



IRAX N°. 67 1LB

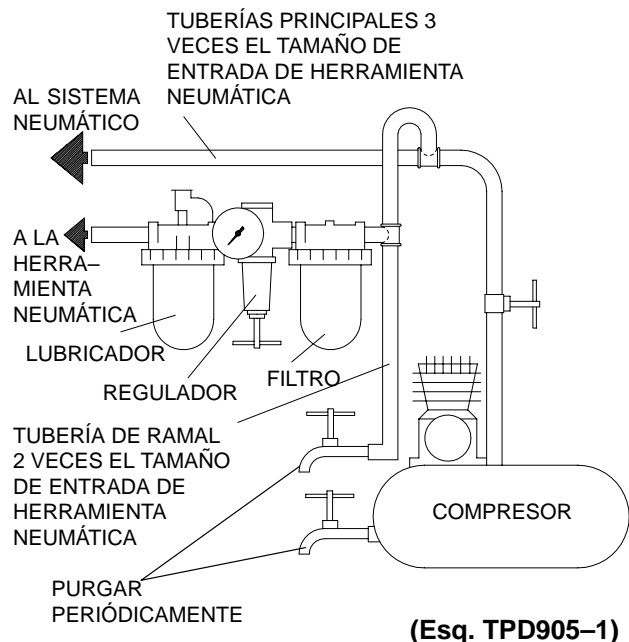

PARA PONER LA HERRAMIENTA EN SERVICIO

ESPECIFICACIONES

Modelo	Velocidad Constante	Muela Tipo 27 y 28		Eje y Cubremuela
	rpm	pulgadas	mm	
GRG15A-06G-7	6.000	7	178	5/8-11, 7"
GRG15A-06G-9	6.000	9	227	5/8-11, 9"
GRG15A-08G-7	7.500	7	178	5/8-11, 7"
GRG15M-06G-7	6.000	7	178	5/8-11, 7"
GRG15M-06G-9	6.000	9	227	5/8-11, 9"
GRG15M-08G-7	7.500	7	178	5/8-11, 7"
Modelo	Velocidad Constante	Placa de Reserva		Eje
	rpm	pulgadas	mm	
GRP15A-02P-7	2.500	7	178	5/8-11, 7"
GRS15A-06S-7	6.000	7	178	5/8-11, 7"
GRS15A-04S-9	4.500	9	228	5/8-11, 9"

ESMERILADORAS, LIXADORAS E POLIDORAS DE ÂNGULO PNEUMÁTICAS SÉRIES GRG15A-06G-7, GRG15A-06G-9, GRG15A-08G-7, GRG15M-06G-7, GRG15M-06G-9, GRG15M-08G-7, GRP15A-02P-7, GRS15A-04S-9, AND GRS15A-06S-7 1.5 H.P.

AVISO

As Esmeriladoras, Lixadoras e Polidoras de Ângulo Pneumáticas Séries GRG, GRS e GRP são concebidas para alisamento, corte de sebes ou remoção de metais em fundições, estaleiros, siderúrgias e em aplicações de construções metálicas.

A ARO não é responsável por modificações, feitas pelo cliente em ferramentas, nas quais a ARO não tenha sido consultada.

⚠️ ADVERTÊNCIA

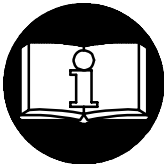

INFORMAÇÃO DE SEGURANÇA IMPORTANTE EM ANEXO.
LEIA ESTE MANUAL ANTES DE OPERAR A FERRAMENTA.
É DA RESPONSABILIDADE DO EMPREGADOR COLOCAR A INFORMAÇÃO
DESTE MANUAL NAS MÃOS DO OPERADOR.

O NÃO CUMPRIMENTO DAS SEGUINTES ADVERTÊNCIAS PODE RESULTAR EM FERIMENTOS.

COLOCANDO A FERRAMENTA EM FUNCIONAMENTO

- Sempre opere, inspecione e mantenha esta ferramenta de acordo com o Código de Segurança do Instituto Americano de Padrões Nacionais para Ferramentas Pneumáticas Portáteis (ANSI B186.1).
- Para segurança, máximo desempenho e máxima durabilidade das peças, opere esta ferramenta com uma pressão de ar máxima de 6,2 bar/620 kPa (90 psig) na entrada da mangueira de alimentação de ar com diâmetro interno de 10 mm (3/8”).
- Desligue sempre a alimentação de ar e desconecte a mangueira de alimentação de ar antes de instalar, remover ou ajustar qualquer acessório nesta ferramenta, ou antes de executar qualquer serviço de manutenção nesta ferramenta.
- Não use mangueiras de ar ou adaptadores danificados, gastos ou deteriorados.
- Certifique-se de que todas as mangueiras e adaptadores sejam do tamanho correcto e estejam apertados com firmeza. Veja o Desenho TPD905-1 para um arranjo típico de tubagem.
- Use sempre ar seco e limpo com pressão máxima de 90 psig. Pó, fumos corrosivos e/ou humidade excessiva podem arruinar o motor de uma ferramenta pneumática.
- Não lubrifique as ferramentas com líquidos inflamáveis ou voláteis tais como querosene, diesel ou combustível de jactos.
- Não remova nenhum rótulo. Reponha qualquer rótulo danificado.

USANDO A FERRAMENTA

- Use sempre óculos de protecção quando estiver operando ou executando serviço de manutenção nesta ferramenta.
- Use sempre protecção contra ruído ao operar esta ferramenta.
- Mantenha as mãos, partes do vestuário soltas e cabelos compridos afastados da extremidade em rotação.
- Antecipe e esteja alerta a mudanças repentinas no movimento quando ligar e operar qualquer ferramenta motorizada.
- Mantenha a posição do corpo equilibrada e firme. Não exagere quando operar esta ferramenta. Torques de reacção elevados podem ocorrer na ou abaixo da pressão de ar recomendada.
- Os acessórios da ferramenta podem continuar a impactar brevemente após a pressão ter sido aliviada.
- Ferramentas accionadas pneumáticamente podem vibrar em uso. Vibração, movimentos repetitivos ou posições desconfortáveis podem ser prejudiciais às mãos e aos braços. Pare de usar a ferramenta caso ocorra algum desconforto, sensação de formigamento ou dor. Procure assistência médica antes de retornar ao trabalho.
- Use acessórios recomendados pela ARO.
- Quando quer que o Cabeçote em Ângulo seja instalado ou reposto, a Válvula Reguladora de Pressão deve ser posicionada de modo que um torque de reacção não tenderá a reter o curso na posição “LIGADA”.
- Esta Ferramenta não foi concebida para trabalhos em atmosferas explosivas.
- Esta Ferramenta não está isolada contra choques eléctricos.

AVISO

O uso de peças de substituição que não sejam genuinamente da ARO podem resultar em riscos de segurança, diminuição do desempenho da ferramenta, aumento da necessidade de manutenção e pode invalidar todas as garantias.

As reparações devem ser feitas somente por pessoal treinado autorizado. Consulte o Centro de Serviços da ARO Tool Products mais próximo.

Para obter informações sobre peças e assistência, contacte o seu distribuidor local ARO.

ARO Tool Products

Ingersoll-Rand Company

1725 U.S. No. 1 North, PO Box 8000, Southern Pines, NC 28388-8000

1999 INGERSOLL-RAND COMPANY Impresso nos E.U.A.

ARO

IDENTIFICAÇÃO DO RÓTULO DE ADVERTÊNCIA

⚠ ADVERTÊNCIA

O NÃO CUMPRIMENTO DAS SEGUINTE ADVERTÊNCIAS PODE RESULTAR EM FERIMENTO.

	⚠ ADVERTÊNCIA Use sempre óculos de protecção quando estiver operando ou executando algum serviço de manutenção nesta ferramenta.
---	--

	⚠ ADVERTÊNCIA Use sempre protecção contra o ruído ao operar esta ferramenta.
---	--

	⚠ ADVERTÊNCIA Desligue sempre a alimentação de ar e desconecte a mangueira de alimentação de ar antes de instalar, remover ou ajustar qualquer acessório nesta ferramenta, ou antes de executar algum serviço de manutenção nesta ferramenta.
---	---

	⚠ ADVERTÊNCIA Ferramentas accionadas pneumáticamente podem vibrar em uso. Vibração, movimentos repetitivos ou posições desconfortáveis podem ser prejudiciais às mãos e aos braços. Pare de usar a ferramenta caso ocorra algum desconforto, sensação de formigamento ou dor. Procure assistência médica antes de retornar ao trabalho.
---	---

	⚠ ADVERTÊNCIA Não carregue a ferramenta segurando na mangueira.
---	---

	⚠ ADVERTÊNCIA Não use mangueiras de ar ou adaptadores danificados, gastos ou deteriorados.
---	--

	⚠ ADVERTÊNCIA Mantenha a posição do corpo equilibrada e firme. Não exagere quando operar esta ferramenta. Torques de reacção elevados podem ocorrer sob a pressão de ar recomendada.
---	--

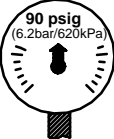
	⚠ ADVERTÊNCIA Opere com pressão do ar Máxima de 90–100 psig (6,2–6,9 bar).
---	--

ADVERTÊNCIAS ESPECÍFICAS SOBRE A ESMERILADORA

⚠ ADVERTÊNCIA

O NÃO CUMPRIMENTO DAS SEGUINTE ADVERTÊNCIAS PODE RESULTAR EM FERIMENTO.

- Não use esta ferramenta se a velocidade livre total exceder a rpm indicada na placa de identificação.
- Antes de montar o disco, depois de qualquer reparação de ferramenta ou quando se pretende que uma Esmeriladora seja colocada em funcionamento, verifique a velocidade livre da Esmeriladora com um tacometro para se certificar de que a sua velocidade real a 6,2 bar/620kPa (90 psig) não exceda a rpm selada ou impressa na placa de identificação. As Esmeriladoras em funcionamento devem ser similarmente verificadas pelo menos uma vez em cada turno.
- Use sempre o Protector do Disco da ARO fornecido com a Esmeriladora.
- Não use qualquer disco de esmerilamento, broca ou outro acessório que possua uma velocidade máxima de operação menor do que a velocidade livre da Esmeriladora que esteja a ser usada. Respeite sempre a máxima rpm nos adaptadores de disco de esmerilamento.
- Verifique todas os discos de esmerilamento para ver se há lascas ou rachaduras antes da montagem. Não use um disco que esteja lascado ou rachado ou de alguma maneira danificado. Não use um disco que tenha sido encharcado com água ou qualquer outro líquido.
- Verifique se o disco de esmerilamento se encaixa na árvore de montagem. Não use rolamentos redutores para adaptar um disco na árvore de montagem a não ser que tais rolamentos tenham sido fornecidos ou recomendados pelo fabricante do disco.
- Depois de montar um novo disco, segure a Esmeriladora sob uma bancada de aço ou dentro de uma moldagem e coloque-a em funcionamento por 60 segundos. Verifique se não há ninguém dentro do plano de operação. Se o disco estiver com algum defeito, inadequadamente montado ou se for do tamanho errado ou tiver velocidade incorrecta, este é o momento em que ele normalmente falhará.
- Quando iniciar um trabalho com um disco frio, ponha-o a trabalhar lentamente até que o disco aqueça gradualmente. Faça um contacto suave com o local a ser trabalhado e evite de executar qualquer ação de batimento ou pressão excessiva.
- Reponha um protector do disco sempre que estiver danificado, torto ou severamente gasto. Não use um protector do disco que tenha sido sujeito a uma falha do disco.

(continua)

ADVERTÊNCIAS ESPECÍFICAS SOBRE A ESMERILADORA

- Certifique-se de que as flanges da roda sejam pelo menos 1/3 do diâmetro do disco de esmerilamento, livre de cortes, arestas e extremidades afiadas. Use sempre flanges do disco fornecidas pelo fabricante. Nunca use uma flange provisória ou uma anilha plana. Aperte bem a Porca da Flange.
- A abertura do protector deve estar afastada do operador. O fundo do disco não deve se estender para fora do protector.
- Use sempre uma pinça cuja dimensão seja igual ao encabadouro acessório.
- Insira sempre o encabadouro da ferramenta com comprimento que não seja inferior a 10 mm no colete. Aperte a Porca do Pinça seguramente para evitar que o acessório se desajuste durante a operação da esmeriladora. Verifique o aperto da Porca do Pinça antes de operar a esmeriladora. Preste particular atenção ao facto de que a velocidade permitida de um ponto montado é diminuída quando o comprimento do eixo é aumentado entre a extremidade da pinça e o ponto montado. (pendurado)

ADVERTÊNCIA: Combinações incorrectas de disco de esmerilamento, protector do disco e velocidade da ferramenta pode resultar em ferimento.

As combinações correctas estão especificadas abaixo:

Número de Peça do Protector	Tipo do Disco	Diâmetro do Disco	Espessura Máxima do Disco	Velocidade Máxima
		mm (pol.)	mm (pol.)	rpm
77A-106-7	27, 28	7 (178)	6,4 (1/4)	7.500
77A-106-9	27, 28	7 (178)	6,4 (1/4)	6.000

COLOCANDO A FERRAMENTA EM FUNCIONAMENTO

LUBRIFICAÇÃO



IRAX No. 50P



IRAX No. 68 1LB

Use sempre um lubrificador de ar de linha com estas ferramentas. Nós recomendamos a seguinte Unidade Filtro-Lubrificador-Regulador:

USA- No. C18-03-FKG0-28

Antes de ligar a Ferramenta, ao menos que um lubrificador de ar de linha seja usado, desligue a mangueira de ar e injecte aproximadamente 2,5 cc de **IRAX No. 50P** óleo na entrada de ar.

Depois de oito horas de operação, substitua o suprimento de óleo. Remova o Bujão da Câmara de óleo do Punho Regulador de Pressão e preencha a câmara.

Depois de quarenta e oito horas de operação, injecte cerca de 5 cc de Massa Lubrificante **IRAX No. 68 1LB** no Adaptador.

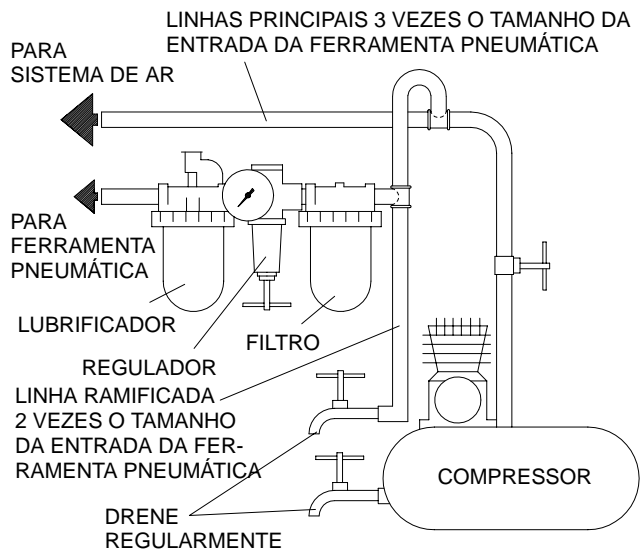

(Desenho TPD905-1)

COLOCANDO A FERRAMENTA EM FUNCIONAMENTO

ESPECIFICAÇÕES

Modelo	Velocidade Livre	Disco Tipo 27 e 28		Veio e Resguardo
		rpm	pol.	
GRG15A-06G-7	6.000	7	178	5/8-11, 7"
GRG15A-06G-9	6.000	9	227	5/8-11, 9"
GRG15A-08G-7	7.500	7	178	5/8-11, 7"
GRG15M-06G-7	6.000	7	178	5/8-11, 7"
GRG15M-06G-9	6.000	9	227	5/8-11, 9"
GRG15M-08G-7	7.500	7	178	5/8-11, 7"
Modelo	Velocidade Livre	Almofada		Veio
		rpm	pol.	
GRP15A-02P-7	2.500	7	178	5/8-11, 7"
GRS15A-06S-7	6.000	7	178	5/8-11, 7"
GRS15A-04S-9	4.500	9	228	5/8-11, 9"

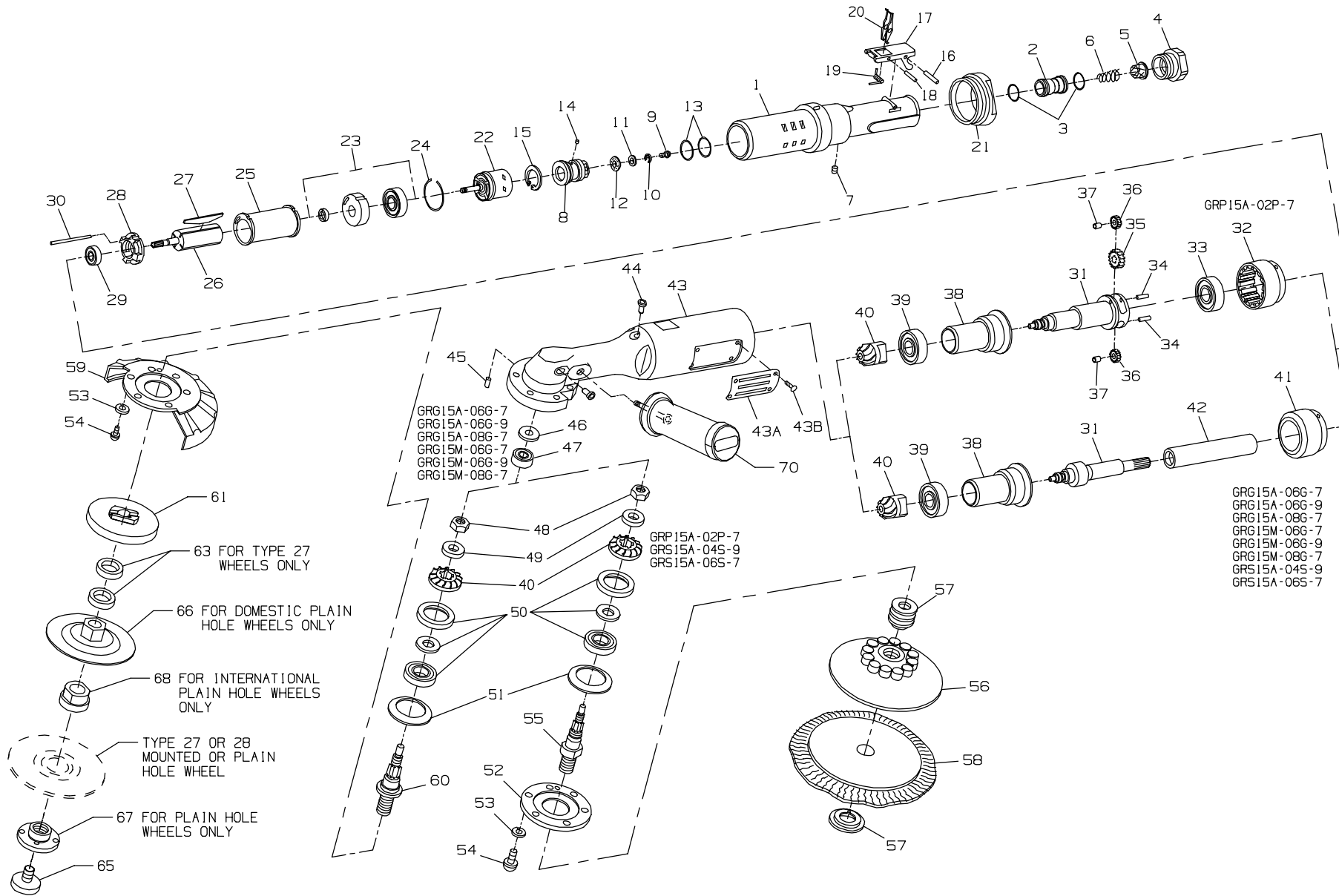

MAINTENANCE SECTION



PART NUMBER FOR ORDERING

PART NUMBER FOR ORDERING

	1	Throttle Handle Assembly	49843-116		23	Rear End Plate Assembly (consists of rear end plate, rotor bearing and required spacers)	77H-A12
	2	Throttle Valve Assembly	88V60-A302			Rear End Plate Gasket	77H-739
◆◆	3	Seal (2)	C321-606		◆◆ 24	Cylinder	77H-3
	4	Inlet Bushing	77H-38		25	Rotor	77H-53RH
◆◆	5	Inlet Bushing Screen	834-61		26	Vane Packet (set of 4 Vanes)	77H-42-4
◆	6	Throttle Valve Spring	77H-262		◆ 27	Front End Plate	77H-11
	7	Oil Chamber Plug	R2-227		◆◆ 28	Front Rotor Bearing	77H-24
	8	Throttle Valve Seat Support Assembly . . .	77H-A303		29	Cylinder Dowel	77H-98
	9	Valve Seat Screw	PS3-83		30	Bevel Pinion Driver	
	10	Valve Seat Lock Washer	H54U-352		31	for GRP15A-02P-7	77A-8
◆◆	11	Valve Seat Washer	99V-155			for all others	77A-7
◆	12	Valve Seat	R4-159A		32	Internal Gear	77H-406
	13	Valve Support Seal (2)	SPP101-743		33	Bevel Pinion Driver Bearing	WFS182-97
	14	Oiler Feeder Plug	77H-75		34	Planet Gear Shaft (2)	G700-191
	15	Throttle Valve Seat Support Retainer	77H-518		35	Rotor Pinion	77H-17
	16	Throttle Lever Pin	MR-100		36	Planet Gear Assembly (2)	77H-A10
	17	Throttle Lever Assembly	77H-A400		37	Planet Gear Bearing (one for each gear) . .	G700-654
	18	Lever Lock Pin	R100B-120		38	Thrust Spacer	77A-104
	19	Lever Lock Spring	DG120-405		39	Bevel Pinion Bearing Assembly	77A-A510
	20	Lever Lock	DG120-402		40	Matched Gear Set (Bevel Gear and Pinion not sold separately)	77A-A552
	21	Coupling Nut	77H-282		41	Motor Spacer	77E-208-H8
	22	Controller Assembly (Consists of Controller and Rear End Plate Assembly)			42	Arbor Coupling	66H-304
		for GRS15A-04S-9	77H90-A524RH		+ 43	Angle Arbor Housing	
		for GRS15A-06S-7, GRG15A-06G-7, GRG15M-06G-7 and GRG15M-06G-9	77H120-A524RH			for models ending in -EU	49842-EU-147
		for GRP15A-02P-7, GRG15A-08G-7 and GRG15M-08G-7	77H150-A524RH			for all other models	49842-104

MAINTENANCE SECTION

- ◆ Indicates Tune-up Kit part.
- To keep downtime to a minimum, it is desirable to have on hand certain repair parts. We recommend that you stock one (pair or set) of each part indicated by a bullet (•) for every four tools in service.
- + Whenever a new Angle Arbor Housing is installed, order the correct Nameplate (43A) and attach it to the Housing with the Nameplate Screws (43B).

PART NUMBER FOR ORDERING

PART NUMBER FOR ORDERING

43A	Nameplate	49842-110	43B	Nameplate Screw (4)	BN403-302
	for model GRG15A-06G-7	49842-111	*	Warning Label	
	for model GRG15A-06G-9	49842-112		for Grinders ending in -EU	EU-99
	for model GRG15A-08G-7	49842-148		for all other Grinders	WARNING-4-99
	for model GRG15M-06G-7	49842-149		for Sanders and Polishers ending	
	for model GRG15M-06G-9	49842-150		in -EU	EU-99
	for model GRG15M-08G-7	49842-150-EU		for all other Sanders and Grinders .	WARNING-5-99
	for model GRG15M-08G-7-EU . .	49842-107			
	for model GRP15A-02P-7	49842-108			
	for model GRS15A-04S-9	49842-109			
	for model GRS15A-06S-7				

* Not illustrated.

PART NUMBER FOR ORDERING

PART NUMBER FOR ORDERING

44	Grease Fitting (2)	130SR-188	65	Wheel Retaining Screw (for all Type 27 and 28 Wheels)	99V60-219
45	Mounting Plate Pin	77A-31	66	Depressed Center Wheel Flange (for Type 27 and 28 Plain Hole Wheels)	99V60-386
• 46	Upper Bearing Spring Washer	4U-278	67	Depressed Center Wheel Nut (for Type 27 and 28 Plain Hole Wheels)	99V85-186
• 47	Upper Arbor Bearing	WWA100-7	*	Depressed Center Wheel Nut Spanner Wrench	D32-26
48	Bevel Gear Nut	77A-578	*	Wheel Flange Wrench (for all GRG models)	TRAQT4-254
49	Bevel Gear Spacer	77A-25	68	Depressed Center Wheel Flange Assembly (for GRG15M-06G-7, GRG15M-06G-9 and GRG15M-08G-7 with Type 27 and Type 28 Plain Hole Depressed Center Wheels)	99V60-386-M
50	Arbor Lower Bearing Assembly	77A-A593	70	Dead Handle	ERG0-A48
51	Lower Arbor Spring Washer	77A-307	72	Nameplate	66H-301
52	Sander Arbor Retaining Plate	77A-55	73	Nameplate Screw (4)	BN403-302
53	Screw Lock Washer (6)	88H60-67	*	Bearing Clamp Assembly	77H-A952
54	Guard Screw or Retaining Plate Screw (6)	77H-638	*	Controller Wrench	77H-950
55	Sander Arbor	77A-204-P10	*	Throttle Valve Seat Support Retainer Pliers	77H-154
56	Sanding Pad Assembly with 5" Sanding Pad	77A-AM825-5	*	Coupling Nut Wrench	77H-281
	with 7" Sanding Pad (medium)	77A-AM825-7	*	1/2" Pipe Tap Inlet Bushing	88V60-38
	with 7" Sanding Pad (firm)	77A-BM825-7	*	Vibra-Tite®** 0.6 cc	5R-VT06
	with 9" Sanding Pad	77A-AM825-9	*	Adhesive Kit	77H-KVLT
57	Pad Mounting Kit	77A-826		Tune-up Kit includes illustrated parts: (3 [2], 5, 6, 12, 13 [2], 24 and 27)	77H77A-TK3
58	Wool Bonnet (for GRP15A-02P-7)	P500-850			
59	Depressed Center Wheel Guard for 7" diameter wheels	77A-106-7			
	for 9" diameter wheels	77A-106-9			
60	Depressed Center Wheel Arbor	77A-4-B10			
61	Autobalancer Assembly	99V60-A713			
*	Autobalancer Wrench (7/8" single-end; open-end wrench)	88V60-169			
63	Depressed Center Wheel Spacer (2 for all Type 27 Mounted Wheel)	99V-286			

* Not illustrated.

• To keep downtime to a minimum, it is desirable to have on hand certain repair parts. We recommend that you stock one (pair or set) of each part indicated by a bullet (•) for every four tools in service.

** Registered trademark of ND Industries.

MAINTENANCE SECTION

WARNING

Always wear eye protection when operating or performing maintenance on this tool.

Always turn off air supply and disconnect air supply hose before installing, removing or adjusting any accessory on this tool, or before performing any maintenance on this tool.

LUBRICATION

Each time a GRG Grinder, GRS Sander, or GRP Polisher is disassembled for maintenance, repair or replacement of parts, lubricate the tool as follows:

1. Moisten all O-rings with O-ring lubricant.
2. Coat the inner surface of the Arbor Coupling (42), the spline of the Rotor (26) and the spline of the Bevel Pinion (31) with 3 to 4 cc of IRAX No. 68-1LB Grease. **Do not substitute any other grease.**
3. After assembling the tool, remove the Oil Chamber Plug (7) and fill the oil chamber with IRAX No. 50P Oil. Tighten the Plug to 3-3/4 to 7-1/2 ft-lb (5 to 10 Nm) torque. Inject 2.5 cc of the recommended oil into the inlet before installing the Inlet Bushing (4).
4. Inject 5 cc of IRAX No. 68-1LB Grease into both Grease Fittings (44).

DISASSEMBLY

General Instructions

1. Do not disassemble the tool any further than necessary to replace or repair damaged parts.
2. Whenever grasping a tool or part in a vise, always use leather-covered or copper-covered vise jaws to protect the surface of the part and help prevent distortion. This is particularly true of threaded members and housings.
3. Do not remove any part which is a press fit in or on a subassembly unless the removal of that part is necessary for repairs or replacement.
4. Do not disassemble the tool unless you have a complete set of new gaskets and O-rings for replacement.

Disassembly of the Angle Head

For GRG15A or GRG15M Models:

1. Grasp the Angle Arbor Housing (43) in leather-covered or copper-covered vise jaws, angle head up.
2. Insert a 5" (127 mm) long 3/16" hex wrench into the elongated slot in the end of the Dead Handle (70) and loosen and remove the screw and the Dead Handle from the Angle Arbor Housing (43).
3. Using the Autobalancer Wrench (Part No. 88V60-169) to hold the Depressed Center Wheel Arbor (60) against rotation, proceed as follows:
 - a. Using a hex wrench, unscrew and remove the Wheel Retaining Screw (65).
 - b. **For Type 27 and 28 Plain Hole Wheels**, use the Depressed Center Wheel Nut Spanner Wrench (Part No. D32-26) to unscrew and remove the Depressed Center Wheel Nut (67). Remove the wheel.
For Type 27 and 28 Mounted Wheels, unscrew the wheel.
 - c. **For Type 27 and 28 Plain Hole Wheels**, unscrew and remove the Depressed Center Wheel Flange (66 or 68).
For Type 27 and 28 Mounted Wheels, remove any Depressed Center Wheel Spacers (63).
4. Slide the Autobalancer Assembly (61) off the Arbor.
5. Unscrew and remove the Wheel Guard Screws (54). Remove the Screw Lock Washers (53) and the Wheel Guard (59).
6. Lift the Depressed Center Wheel Arbor (60) from the Angle Arbor Housing.

WARNING

Do not remove the Mounting Plate Pin (45) unless it is bent or broken. The Mounting Plate Pin is the alignment pin for the Wheel Guard and must be used to assure correct mounting of the Wheel Guard. Use pliers to remove the Mounting Plate Pin if removal is necessary and a new Pin is available.

7. Remove the Angle Arbor Housing from the vise.
8. Lay the Angle Arbor Housing on a workbench, guard side down. Lightly tap the angle arbor housing head with a soft hammer to release the Upper Arbor Bearing (47) and Upper Bearing Spring Washer (46).

MAINTENANCE SECTION

CAUTION

A thread locking compound was applied to the threads of the Bevel Gear Nut (48) during assembly. It may be necessary to warm the Nut with a propane torch in order to remove it. Use only enough heat to warm the Nut for removal. Do not overheat.

9. Grasp the flats of the Depressed Center Wheel Arbor in leather-covered or copper-covered vise jaws, Arbor Bearing end up. Using a wrench, remove the Bevel Gear Nut.
10. Remove the Bevel Gear Spacer (49) and Bevel Gear (40).
11. Press the Arbor Lower Bearing Assembly (50) from the Arbor. Remove the Lower Arbor Spring Washer (51). Remove the Arbor from the vise.

For GRP15A or GRS15A Models:

1. Grasp the Angle Arbor Housing (43) in leather-covered or copper-covered vise jaws, angle head up.
2. Use a No. DG120-69 Sander Arbor Wrench to hold the Arbor (55). Remove the Pad Mounting Kit Nut (57).
3. **For GRP15A Models**, remove the Wool Bonnet (58). Unscrew and remove the Sanding Pad Assembly (56).
4. **For GRS15A Models**, remove the Sanding Pad Assembly.
5. Remove the Pad Mounting Kit washers (57).
6. Unscrew and remove the Retaining Plate Screws (54). Remove the Screw Lock Washers (53) and the Sander Arbor Retaining Plate (52).

⚠ WARNING

Do not remove the Mounting Plate Pin (45) unless it is bent or broken. The Mounting Plate Pin is the alignment pin for the Sander Arbor Retaining Plate. Use pliers to remove the Mounting Plate Pin if removal is necessary and a new Pin is on hand.

7. Remove the Angle Arbor Housing from the vise.
8. Lay the Angle Arbor Housing (43) on a workbench, guard side down. Lightly tap the Angle Arbor Housing with a soft hammer to release the Upper Arbor Bearing (47) and Upper Bearing Spring Washer (46).

CAUTION

A thread locking compound was applied to the threads of the Bevel Gear Nut (48) during assembly. It may be necessary to warm the Nut with a propane torch in order to remove it. Use

only enough heat to warm the Nut for removal. Do not overheat.

9. Grasp the flats of the Sander Arbor (55) in leather-covered or copper-covered vise jaws, arbor bearing end up. Using a wrench, remove the Bevel Gear Nut.
10. Remove the Bevel Gear Spacer (49) and Bevel Gear (40).
11. Press the Arbor Lower Bearing Assembly (50) from the Arbor. Remove the Lower Arbor Spring Washer (51). Remove the Arbor from the vise.

Disassembly of the Throttle Lever and Inlet

1. Grasp the flats of the Throttle Handle (1) in leather-covered or copper-covered vise jaws, air inlet up.
2. Remove the Inlet Bushing (4), Inlet Bushing Screen (5) and the Throttle Valve Spring (6). The Bushing has an interference thread and is tightly fit.
3. Drive out the Throttle Lever Pin (16) to release the Throttle Lever Assembly (17).
4. Remove the Throttle Handle from the vise.
5. Using a soft hammer, tap the arbor end of the housing to release the Throttle Valve Assembly (2), or using snap ring pliers, pull the Assembly from the Throttle Handle. Remove the two Seals (3).

Disassembly of the Motor and Throttle

1. Grasp the Angle Arbor Housing (43) horizontally in leather-covered or copper-covered vise jaws.
2. Using No. 77H-281 Coupling Nut Wrench, remove the Coupling Nut (21).
3. Grasp the Throttle Handle (1) and pull the Handle from the Arbor Housing.
4. Grasp the splined end of the Rotor (26) and pull the motor from the Throttle Handle.
5. Remove the Cylinder Dowel (30).
6. Grasp the splined end of the Rotor in leather-covered or copper-covered vise jaws.
7. Remove the Front End Plate (28) and Front Rotor Bearing (29) from the Rotor.
8. If the Front Rotor Bearing needs to be replaced, press it from the Front End Plate.
9. Lift off the Cylinder (25).
10. Remove the Vanes (27).

MAINTENANCE SECTION

NOTICE

A thread locking compound was applied to the threads of the Rotor during assembly to prevent the Controller Assembly (22) from loosening during operation. Before attempting to unscrew the assembly from the Rotor, apply moderate heat from a propane torch to the middle of the rotor body to soften the compound. Do not overheat the Rotor. Heat it only long enough to allow the Controller Assembly to be unscrewed without using excessive force.

CAUTION

Use only the special Controller Wrench for removing the Controller Assembly. Do not attempt to disassemble the Controller. It is available only as a unit and is guaranteed for the life of the Grinder if it is not abused.

- Using the No. 77H-950 Controller Wrench, unscrew and remove the Controller Assembly (22).

NOTICE

The Rear End Plate, Spacer and Bearing are a matched set. Do not mix the components with those of another set. The Rear Rotor Bearing is always damaged during the removal process, and a complete new Rear End Plate Assembly must be installed.

- If the Rear End Plate Assembly (23) consisting of the Rear End Plate, Spacer and Bearing needs to be replaced, press it from the Controller.
- Remove the Rear End Plate Gasket (24).
- Using No. 77H-154 Retainer Pliers, remove the Throttle Valve Seat Support Retainer (15).
- Grasp the Throttle Handle horizontally in leather-covered or copper-covered vise jaws. Using a brass rod 8" (204 mm) long inserted into the air inlet end of the handle, lightly tap the brass rod with a soft hammer to release the Throttle Valve Seat Support Assembly (8).
- Remove the Valve Seat Screw (9), Valve Seat Lock Washer (10), Valve Seat Washer (11), Valve Seat (12) and Valve Support Seals (13).
- Check the Oiler Feeder Plug (14). Replace if necessary.

Disassembly of the Bevel Pinion Driver

For GRP15A-02P-7 Models:

- Lightly tap the Angle Arbor Housing (43) to release the Bevel Pinion Driver (31).
- Remove the Internal Gear (32).
- Remove the Bevel Pinion Driver Bearing (33). This is a light press fit.

- Check the Planet Gears (36) and Planet Gear Bearings (37) for wear. If they need to be replaced, proceed as follows:

NOTICE

Always remove the Planet Gear Shafts (34) in the direction shown on the drawing.

- Using a pin punch and soft hammer, remove the Planet Gear Shaft.
- Remove the Planet Gear Assembly.
- Remove the Planet Gear Bearing from inside the Planet Gear.
- Remove the Rotor Pinion (35).

NOTICE

Always replace both Planet Gears even if only one Planet Gear shows wear.

- Remove the second Planet Gear as previously instructed.
- Unscrew and remove the Pinion (40).

NOTICE

If the Pinion is worn or broken, replace both the Pinion and Bevel Gear as they are a matched set and cannot be matched with other Bevel Gears.

- Press the Bevel Pinion Bearing (39) from the Bevel Pinion Driver.
- Remove the Thrust Spacer (38).

For GRG15A, GRG15M or GRS15A Models:

- Lightly tap the Angle Arbor Housing (43) to remove the Motor Spacer (41), Arbor Coupling (42), Thrust Spacer (38), Bevel Pinion Bearing Assembly (39), and the Bevel Pinion Driver (31).
- Unscrew and remove the Bevel Pinion (40).

NOTICE

If the Pinion is worn or broken, replace both the Pinion and the Bevel Gear as they are a matched set and cannot be matched with other Bevel Gears.

- Press the Bevel Pinion Bearing (39) from the Bevel Pinion Driver.

ASSEMBLY

General Instructions

- Always press on the **inner** ring of a ball-type bearing when installing the bearing on a shaft.
- Always press on the **outer** ring of a ball-type bearing when pressing the bearing into a bearing recess.
- Whenever grasping a tool or part in a vise, always use leather-covered or copper-covered vise jaws. Take extra care with threaded parts and housings.

MAINTENANCE SECTION

4. Always clean every part and wipe every part with a thin film of oil before installation.
5. Apply a film of o-ring lubricant to all O-rings before final assembly.

Assembly of the Motor and Throttle

1. Assemble the Throttle Valve Seat Support Assembly (8). Secure the Valve Seat (12), the Valve Seat Washer (11), and the Valve Seat Lock Washer (10) with the Valve Seat Screw (9). Tighten the Valve Seat Screw between 0.75 to 2.25 ft-lb (1 to 3 Nm) torque. Apply o-ring lubricant to the Valve Support Seals (13) before installing them on the Throttle Valve Seat Support.
2. Insert the Assembly into the large diameter of the handle, Valve Seat Screw end first.
3. Using No. 49843-146 Retainer Pliers, install the Throttle Valve Seat Support Retainer (15).
4. Press the Front Rotor Bearing (29), with Front End Plate (28), onto the rotor shaft.
5. Grasp the splined end of the Rotor (26) in leather-covered or copper-covered vise jaws.
6. Place the Cylinder (25) over the Rotor, aligning the dowel hole in the Cylinder with the dowel hole in the Front End Plate.
7. Apply a film of the recommended oil to each Vane (27) and insert a Vane, straight edge out, into each vane slot in the Rotor. If new Vanes are required, replace the entire set.
8. Check the large inside diameter of the Rear End Plate Assembly (23) for wear. If the large inside diameter of the Rear End Plate is worn to 1.516" (38.506 mm) or larger, install a new Rear End Plate Assembly.

NOTICE

If the Controller Assembly must be replaced, it is furnished with a new Rear End Plate Assembly. Use only the End Plate Assembly furnished with the Controller Assembly. If the Controller is good but the Rear End Plate Assembly needs replacement, only install a new Rear End Plate Assembly. Do not use or interchange old parts with new Rear End Plate Assembly components. The End Plate, Spacer and Bearing are a matched set. Do not mix components with those of another set. The Rear Rotor Bearing is always damaged during removal and a new Rear End Plate Assembly must be installed.

9. Press the Rear End Plate Assembly onto the shaft of the controller body making certain the marked end of the Bearing faces toward the Controller or rear of the Grinder. Also make certain that the beveled end of the Spacer faces the Cylinder or front of the Grinder.

10. Clean the threads of the Controller Assembly (22) and apply two or three drops of a thread locking compound to the threads. Thread the Controller onto the Rotor.

CAUTION

Before tightening the Controller, be certain that the dowel holes in the Cylinder and End Plate are aligned. Use the 77H-950 Controller Wrench to tighten the Controller between 7.5 and 8.0 ft-lb (10.1 and 10.8 Nm) torque. Do not exceed 8 ft-lb (10.8 Nm) torque because it could damage the Controller. Allow the thread locking compound to cure for six hours before putting the Grinder back in service.

WARNING

Always check the free speed of the Grinder after it has been reassembled and before it is put back into service. Never use a Grinder with a free speed that exceeds the maximum speed listed on the Nameplate.

11. Remove the Rotor from the vise.
12. Insert the Cylinder Dowel (30) so it is flush with the face of the Front End Plate and protrudes from the back of the Rear End Plate Assembly.
13. Install a new End Plate Gasket (24) into the Throttle Handle (1).
14. Install the assembled motor into the Throttle Handle (1), making sure the Cylinder Dowel (30) aligns with the pin hole inside the Throttle Handle.

Assembly of the Bevel Pinion Driver

1. **For GRP15A Models:**
 - a. Install the Planet Gear Bearings (37) into the Planet Gears (36).
 - b. Install an assembled Planet Gear into one of the slots in the gear head. Make sure the shaft hole aligns in both the Planet Gear and the gear head.
 - c. Press the Planet Gear Shaft (34) into the hole opposite the tapered shaft hole in the gear head until it is flush with the face of the gear head.
 - d. Install the Rotor Pinion (35), making sure the teeth of the Planet Gear and Rotor Pinion mesh. Install the other assembled Planet Gear into the remaining slot of the gearhead. Make sure the teeth of the Planet Gear and the Rotor Pinion mesh and the shaft hole aligns in both the Planet Gear and gear head.
 - e. Press the other Planet Gear Shaft (34) into the hole opposite the tapered shaft hole in the gear head until it is flush with the face of the gear head. Lubricate the Gearing liberally with IRAX No. 68-1LB Grease.

MAINTENANCE SECTION

- f. Press the Bevel Pinion Driver Bearing (33) onto the gear head end of the Bevel Pinion Driver (31).
- g. Install the Internal Gear (32) over the gear head end of the Bevel Pinion Driver, making sure the splines of the Internal Gear mesh with the Planet Gear teeth.
- h. Install the Thrust Spacer (38) over the threaded end of the Bevel Pinion Driver.
- i. Press the Bevel Pinion Bearing (39) onto the Bevel Pinion Driver.

NOTICE

If the Pinion (40) needs to be replaced, replace both the Pinion and Bevel Gear. They are a matched set and cannot be matched with other Bevel Gears.

- j. Check the Pinion for worn or broken teeth.
- k. Screw the Pinion onto the threaded Bevel Pinion Driver and tighten to 14 to 19 ft-lb (19 to 26 Nm) torque.

For GRG15A, GRG15M or GRS15A Models:

- a. Press the Bevel Pinion Bearing (39) over the threaded end and onto the Bevel Pinion Driver (31).

NOTICE

If the Pinion (40) needs to be replaced, replace both the Pinion and the Bevel Gear. They are a matched set and cannot be matched with other Bevel Gears.

- b. Check the Pinion for worn or broken teeth.
 - c. Screw the Pinion onto the Bevel Pinion Driver and tighten to 14 to 19 ft-lb (19 to 26 Nm) torque.
 - d. Coat the inner surface of the Arbor Coupling (42), the spline of the Rotor (26) and the spline of the Bevel Pinion Driver with 3 to 4 cc of IRAX No. 68-1LB Grease. **Do not substitute any other grease.**
 - e. Install the Arbor Coupling onto the spline end of the Bevel Pinion Driver.
 - f. Install the Thrust Spacer (38) over the Arbor Coupling (42) until it is against the Bevel Pinion Bearing.
2. Grasp the Angle Arbor Housing (43) horizontally in leather-covered or copper-covered vise jaws.
 3. Slide the assembled Bevel Pinion Driver into the Angle Arbor Housing.
 4. **For GRG15A, GRG15M or GRS15A Models**, next install the Motor Spacer (41).

** Registered trademark of N.D. Industries

NOTICE

Make sure the Throttle Lever Assembly (17) mounting boss on the Throttle Handle (1) aligns with the closed, upper portion of the Angle Arbor Housing.

CAUTION

For GRP15A-02P-7 Models, make sure the spline on the Rotor (26) properly engages the spline in the Rotor Pinion (35).

5. Slide the assembled Throttle Handle into the Angle Arbor Housing.
6. Clean the Coupling Nut (21) threads and carefully apply a uniform coat of Vibra-Tite®** VC3 No. 205 to at least the first three threads. Allow the Vibra-Tite to cure for ten to twenty minutes before assembly.

CAUTION

Do not exceed 52.5 ft-lb (71.2 Nm) torque. The motor may be damaged if this torque is exceeded.

7. Using the No. 49843-147 Coupling Nut Wrench, install the Coupling Nut and tighten it between 48 to 52.5 ft-lb (64 to 71 Nm) torque.

Assembly of the Throttle Lever and Inlet

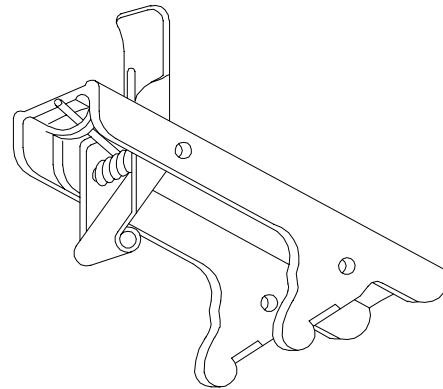

Locking Lever Assembly (Dwg. TPD662)

1. Assemble the Throttle Lever Assembly (17) as illustrated.
2. Align the holes in the Throttle Lever Assembly with the slots in the Throttle Handle. Using a soft hammer, tap the Throttle Lever Pin (16) into the Throttle Lever Assembly until it slightly protrudes from the opposite end. File off any sharp edges. Operate the mechanism to assure operation.
3. Grasp the flats of the Throttle Handle Assembly (1) in leather-covered or copper-covered vise jaws, air inlet up.

MAINTENANCE SECTION

4. Insert the Throttle Valve Spring (6), small end first, into the Handle.

NOTICE

The Inlet Bushing (4) has an interference thread. Apply a light film of the recommended oil to the threads before assembly.

5. Clean the face of Inlet Bushing (4) and the Inlet Bushing Screen (5) with a clean, suitable, cleaning solution and allow to dry. Insert the parts into the end of the Throttle Handle. Tighten the Inlet Bushing to 125 ± 26 ft-lb (170 ± 35 Nm) torque.

Assembly of the Angle Head

For GRG15A or GRG15M Models:

1. Install the Lower Arbor Spring Washer (51) onto the Depressed Center Wheel Arbor (60).
2. Press the Arbor Lower Bearing (50) onto the Depressed Center Wheel Arbor until it contacts the Lower Arbor Spring Washer.

NOTICE

If the Bevel Gear (40) is worn or broken, replace both the Bevel Gear and the Pinion as they are a matched set and cannot be matched with other Pinions.

3. Grasp the flats of the Depressed Center Wheel Arbor in leather-covered or copper-covered vise jaws, arbor bearing end up. Install the Bevel Gear on the Arbor.
4. Install the Bevel Gear Spacer (49).
5. Clean the threads on the Arbor; apply a film of thread locking compound to the threads. Screw the Bevel Gear Nut (48) onto the Arbor and tighten to 8.5 to 11.5 ft-lb (11.5 to 15.5 Nm) torque. Remove the Arbor from the vise.
6. Grasp the Angle Arbor Housing (43) in leather-covered or copper-covered vise jaws, angle head up. Install the Upper Bearing Spring Washer (46) and Upper Arbor Bearing (47).
7. If replacement of the Mounting Plate Pin (45) is necessary, press a new pin into the Angle Arbor Housing.
8. Install the assembled Depressed Center Wheel Arbor into the Angle Arbor Housing.
9. Place the Depressed Center Wheel Guard (59) in position on the Angle Arbor Housing, making sure the Mounting Plate Pin aligns with the pin hole in the guard.
10. Install the Screw Lock Washers (53) and Guard Screws (54). Tighten to 7.5 to 8 ft-lb (10 to 11 Nm) torque.
11. Slide the Autobalancer Assembly (61), rectangular hub side leading, onto the Arbor.

12. To mount the wheel on the tool, proceed as follows:
For Type 27 and Type 28 Plain Hole Wheels:
 - a. Thread the Depressed Center Wheel Flange (66 or 68) onto the Arbor against the Autobalancer Assembly.
 - b. Slide the wheel onto the Arbor against the Depressed Center Wheel Flange.
 - c. Thread the Depressed Center Wheel Nut onto the Arbor against the wheel and tighten the Nut using the Depressed Center Wheel Spanner Wrench (Part No. D32-26). Tighten the Nut only enough to drive the wheel and prevent slippage.
 - d. Using a hex wrench, install the Wheel Retaining Screw (65) in the end of the Arbor.

For Type 27 Mounted Wheels:

- a. Install two Depressed Center Wheel Spacers (63) on the Arbor against the Autobalancer Assembly.
- b. Thread the wheel onto the Arbor.
- c. Using the hex wrench, install the Wheel Retaining Screw (65) in the end of the Arbor.

For Type 28 Mounted Wheels:

- a. Install one Depressed Center Wheel Spacer (63) on the Arbor against the Autobalancer Assembly.
- b. Thread the wheel onto the Arbor.
- c. Using the hex wrench, install the Wheel Retaining Screw (65) in the end of the Arbor.

13. Insert a 5" (127 mm) long 3/16" hex wrench into the elongated slot in the end of the Dead Handle (70) and into the hex recess in the screw head.
14. Position the Handle against the Angle Arbor Housing (43) and thread the screw into the Housing. The Handle can be attached at either of two positions 180 degrees apart. Select the desired position and tighten the screw to 18 ft-lb. (24.4 Nm) torque.
15. Inject approximately 5 cc of IRAX No. 68 -1LB Grease into each Grease Fitting (44).

For GRP15A, GRS15A Models:

1. Install the Lower Arbor Spring Washer (51) onto the Sander Arbor (55). Press the Arbor Lower Bearing (50) onto the Arbor until it contacts the Lower Arbor Spring Washer.

NOTICE

If the Bevel Gear (40) is worn or broken, replace both the Bevel Gear and the Pinion as they are a matched set and cannot be matched with other Pinions.

2. Grasp the flats of the Arbor in leather-covered or copper-covered vise jaws, arbor bearing end up. Install the Bevel Gear on the Arbor.
3. Install the Bevel Gear Spacer (49).

MAINTENANCE SECTION

4. Clean the threads on the Arbor; apply a film of thread locking compound to the threads. Screw the Bevel Gear Nut (48) onto the Arbor and tighten to 8.5 to 11.5 ft-lb (11.5 to 15.5 Nm) torque. Remove the Arbor from the vise.
5. Grasp the Angle Arbor Housing (43) in or leather-covered copper-covered vise jaws, angle head up. Install the Upper Bearing Spring Washer (46) and Upper Arbor Bearing (47).
6. If replacement of the Mounting Plate Pin (45) is necessary, press a new pin into the Angle Arbor Housing.
7. Install the assembled Depressed Center Wheel Arbor (55) into the Angle Arbor Housing.
8. Place the Sander Arbor Retaining Plate (52) in position on the Angle Arbor Housing.
9. Install the Screw Lock Washers (53) and Retaining Plate Screws. Tighten to 7.5 to 8 ft-lb (10 to 11 Nm) torque.
10. Install the Pad Mounting Kit Spacers (57) and Sanding Pad Assembly (56).
For GRP15A Models, install the Wool Bonnet (58).
11. Using the No. 49845-217 Sander Arbor Wrench to hold the arbor, install the Pad Mounting Kit Nut (57) and tighten securely.
12. Insert a 5" (127 mm) long 3/16" hex wrench into the elongated slot in the end of the Dead Handle (70) and into the hex recess in the screw head.
13. Position the Handle against the Angle Arbor Housing (43) and thread the screw into the Housing. The Handle can be attached at either of two positions 180 degrees apart. Select the desired position and tighten the screw to 18 ft-lb. (24.4 Nm) torque.
14. Apply approximately 5 cc of IRAX No. 68-1LB Grease into each Grease Fitting (44).

TROUBLESHOOTING GUIDE

Trouble	Probable Cause	Solution
Low power or low free speed	Insufficient air pressure at the inlet	Check the air pressure at the inlet of the Tool. It must be 90 psig (6.2 bar/620 kPa).
	Plugged Screen	Clean the Inlet Bushing Screen in a clean, suitable, cleaning solution. If it cannot be cleaned, replace it. <div style="text-align: center;">⚠ WARNING</div> <p>Never operate a Grinder without an Inlet Bushing Screen. Ingestion of dirt into the Grinder can, in some cases, cause an unsafe condition.</p>
	Worn or broken Vanes	Replace a complete set of new Vanes.
	Worn or broken Cylinder	Replace the Cylinder if it appears cracked or if the bore is wavy or scored.
	Improper lubrication or dirt build-up in the motor	Lubricate the Grinder as instructed in LUBRICATION . If lubrication does not result in satisfactory operation, disassemble the motor, clean and inspect all parts.

MAINTENANCE SECTION

TROUBLESHOOTING GUIDE

Trouble	Probable Cause	Solution
Rough operation	Worn or broken Rear End Plate Assembly or Front Rotor Bearing	Examine each bearing. Replace the Rear End Plate Assembly if worn or damaged or replace the Front Rotor Bearing. <div style="text-align: center;">NOTICE</div> Rear End Plate Assembly is a matched set. See disassembly and assembly instructions.
	Worn or broken Bevel Gear or Pinion	Check for worn or broken teeth. If a replacement is necessary, install both the Bevel Gear and Pinion. They are a matched set and must not be mismatched.
	Bent Arbor	Mount the Arbor on centers. Check bearing diameter runout with an indicator. Replace the Arbor if runout exceeds 0.002" (0.051 mm) Total Indicator Reading.
Scoring	Improper assembly	Make certain that all motor parts are properly aligned prior to installing the Handle Assembly into the Arbor Housing.
Air leaks	Worn Valve Seat or Valve Seat Washer	Replace worn parts.
	Worn Throttle Valve Seals	Replace both Seals.
	Oil Chamber Plug worn or not tight	Tighten the Plug. If the problem persists, replace the Plug.
High free speed	Worn Rear End Plate Assembly and/or Controller Seal	Replace the Rear End Plate Assembly if the large inside diameter of the Rear End Plate is worn to 1.156" (38.506 mm) or larger.
Grinder will not run	Coupling Nut too tight	Loosen Coupling Nut and retighten to 47.5 to 52.5 ft-lb (64.5 to 71.5 Nm) torque. <div style="text-align: center;">⚠ WARNING</div> Do not exceed 52.5 ft-lb (71.5 Nm) torque.

NOTICE

SAVE THESE INSTRUCTIONS. DO NOT DESTROY.