

Friedrich[®]

Service Manual 2006

Room Air Conditioners

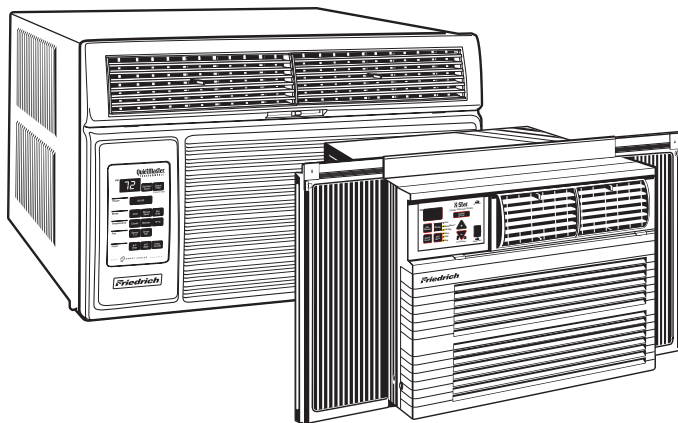

TABLE OF CONTENTS

Warranty	3
Routine Maintenance	4
Unit Identification / Nomenclature.....	5
Performance Data	6
Electrical Data	7
Functional Component Definitions	8
Electronic Controls	8-9
Refrigeration Sequence of Operation.....	10
Sealed Refrigeration Repairs.....	10-11
Refrigerant Charging	12-14
Troubleshooting	15-22
Wiring Diagrams	23-35

WARNING

The information contained in this manual is intended for use by a qualified service technician who is familiar with the safety procedures required in installation and repair, and who is equipped with the proper tools and test instruments.

Installation or repairs made by unqualified persons can result in hazards subjecting the unqualified person making such repairs to the risk of injury or electrical shock which can be serious or even fatal not only to them, but also to persons being served by the equipment.

If you install or perform service on equipment, you must assume responsibility for any bodily injury or property damage which may result to you or others. Friedrich Air Conditioning Company will not be responsible for any injury or property damage arising from improper installation, service, and/or service procedures.

INTRODUCTION

This service manual is designed to be used in conjunction with the installation manuals provided with each air conditioning system component.

This service manual was written to assist the professional RAC service technician to quickly and accurately diagnose and repair malfunctions.

This manual will deal with subjects in a general nature. (i.e. all text will not pertain to all models).

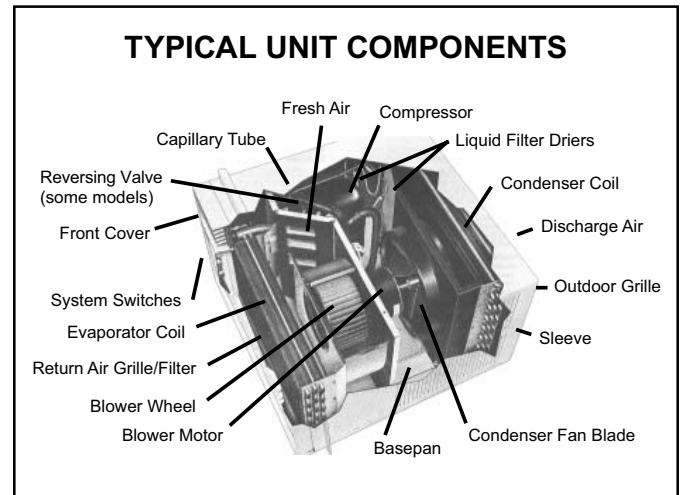

IMPORTANT: It will be necessary for you to accurately identify the unit you are servicing, so you can be certain of a proper diagnosis and repair (See Unit Identification).



Friedrich Air Conditioning Company
P.O. Box 1540
San Antonio, TX 78295
210.357.4400
www.friedrich.com

ROOM AIR CONDITIONERS LIMITED WARRANTY

FIRST YEAR

ANY PART: If any part supplied by FRIEDRICH fails because of a defect in workmanship or material within twelve months from date of original purchase, FRIEDRICH will repair the product at no charge, provided room air conditioner is reasonably accessible for service. Any additional labor cost for removing inaccessible units and/or charges for mileage related to travel by a Service Agency that exceeds 25 miles one way will be the responsibility of the owner. This remedy is expressly agreed to be the exclusive remedy within twelve months from the date of the original purchase.

SECOND THROUGH FIFTH YEAR

SEALED REFRIGERANT SYSTEM: If the Sealed Refrigeration System (defined for this purpose as the compressor, condenser coil, evaporator coil, reversing valve, check valve, capillary, filter drier, and all interconnecting tubing) supplied by FRIEDRICH in your Room Air Conditioner fails because of a defect in workmanship or material within sixty months from date of purchase, FRIEDRICH will pay a labor allowance and parts necessary to repair the Sealed Refrigeration System; **PROVIDED** FRIEDRICH will not pay the cost of diagnosis of the problem, removal, freight charges, and transportation of the air conditioner to and from the Service Agency, and the reinstallation charges associated with repair of the Sealed Refrigeration System. All such cost will be the sole responsibility of the owner. This remedy is expressly agreed to be the exclusive remedy within sixty months from the date of the original purchase.

APPLICABILITY AND LIMITATIONS: This warranty is applicable only to units retained within the Fifty States of the U.S.A., District of Columbia, and Canada. This warranty is not applicable to:

1. Air filters or fuses.
2. Products on which the model and serial numbers have been removed.
3. Products which have defects or damage which results from improper installation, wiring, electrical current characteristics, or maintenance; or caused by accident, misuse or abuse, fire, flood, alterations and/or misapplication of the product and/or units installed in a corrosive atmosphere, default or delay in performance caused by war, government restrictions or restraints, strikes, material shortages beyond the control of FRIEDRICH, or acts of God.

OBTAINING WARRANTY PERFORMANCE: Service will be provided by the **FRIEDRICH Authorized Dealer or Service Organization** in your area. They are listed in the Yellow Pages. If assistance is required in obtaining warranty performance, write to: Room Air Conditioner Service Manager, Friedrich Air Conditioning Co., P.O. Box 1540, San Antonio, TX 78295-1540.

LIMITATIONS: **THIS WARRANTY IS GIVEN IN LIEU OF ALL OTHER WARRANTIES. Anything in the warranty notwithstanding, ANY IMPLIED WARRANTIES OF FITNESS FOR PARTICULAR PURPOSE AND/OR MERCHANTABILITY SHALL BE LIMITED TO THE DURATION OF THIS EXPRESS WARRANTY. MANUFACTURER EXPRESSLY DISCLAIMS AND EXCLUDES ANY LIABILITY FOR CONSEQUENTIAL OR INCIDENTAL DAMAGE FOR BREACH OF ANY EXPRESSED OR IMPLIED WARRANTY.**

NOTE: Some states do not allow limitations on how long an implied warranty lasts, or do not allow the limitation or exclusion of consequential or incidental damages, so the foregoing exclusions and limitations may not apply to you.

OTHER: This warranty gives you specific legal rights, and you may also have other rights which vary from state to state.

PROOF OF PURCHASE: Owner must provide proof of purchase in order to receive any warranty related services.

All service calls for explaining the operation of this product will be the sole responsibility of the consumer.

All warranty service must be provided by an **Authorized FRIEDRICH Service Agency**, unless authorized by FRIEDRICH prior to repairs being made.

(10-04)

ROUTINE MAINTENANCE

NOTE: Units are to be inspected and serviced by qualified service personnel only.

Routine maintenance is required annually or semi-annually, depending upon annual usage.

1. Clean the unit air intake filter at least every 250 to 300 fan hours of operation or when the unit's indicator light is on if so equipped. Clean the filters with a mild detergent in warm water and allow to dry thoroughly before reinstalling.
2. The indoor coil (evaporator coil), the outdoor coil (condenser coil) and base pan should be inspected periodically (yearly or bi-yearly) and cleaned of all debris (lint, dirt, leaves, paper, etc.). Clean the coils and base pan with a soft brush and compressed air or vacuum. If using a pressure washer, be careful not to bend the aluminium fin pack. Use a sweeping up and down motion in the direction of the vertical aluminum fin pack when pressure cleaning coils. Cover all electrical components to protect them from water or spray. Allow the unit to dry thoroughly before reinstalling it in the sleeve.

NOTE: Do not use a caustic coil cleaning agent on coils or base pan. Use a biodegradable cleaning agent and degreaser.

Inspect the indoor blower housing, evaporator blade, condenser fan blade, and condenser shroud periodically (yearly or bi-yearly) and clean of all debris (lint, dirt, mold, fungus, etc.) Clean the blower housing area and blower wheel with an antibacterial / antifungal cleaner. Use a biodegradable cleaning agent and degreaser on condenser fan and condenser shroud. Use warm or cold water when rinsing these items. Allow all items to dry thoroughly before reinstalling them.

3. Periodically (at least yearly or bi-yearly): inspect all control components, both electrical and mechanical, as well as the power supply. Use proper testing instruments (voltmeter, ohmmeter, ammeter, wattmeter, etc.) to perform electrical tests. Use an air conditioning or refrigeration thermometer to check room, outdoor and coil operating temperatures. Use a sling psychrometer to measure wet bulb temperatures indoors and outdoors.
4. Inspect the surrounding area (inside and outside) to ensure that the units' clearances have not been compromised or altered.
5. Inspect the sleeve and drain system periodically (at least yearly or bi-yearly) and clean of all obstructions and debris. Clean both areas with an antibacterial and antifungal cleaner. Rinse both items thoroughly with water and ensure that the drain outlets are operating correctly. Check the sealant around the sleeve and reseal areas as needed.
6. Clean the front cover when needed. Use a mild detergent. Wash and rinse with warm water. Allow it to dry thoroughly before reinstalling it in the chassis.

UNIT IDENTIFICATION

Model Number Code

S S 08 L 1 0 A

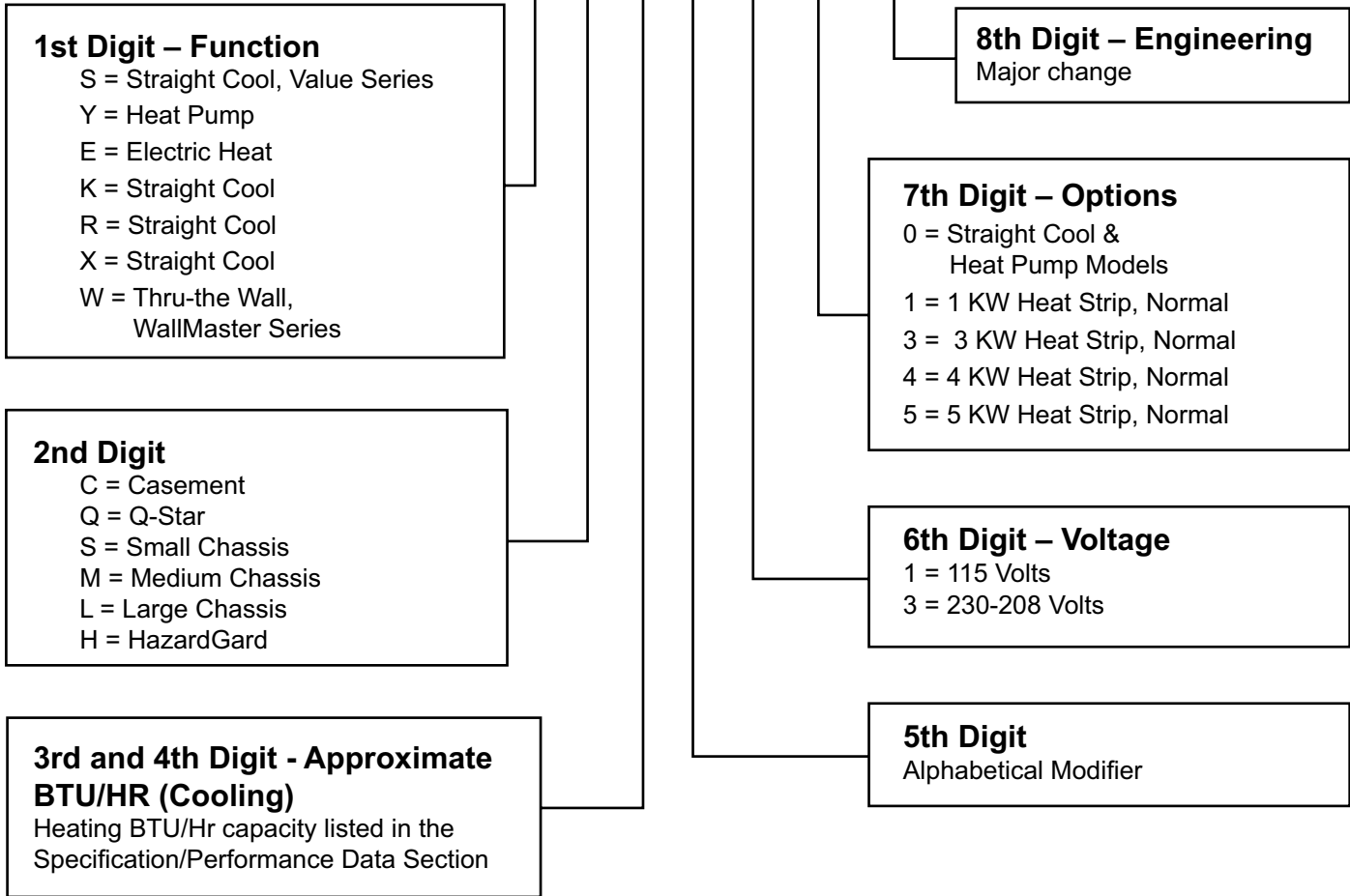

RAC Serial Number Identification Guide

<p>Serial Number</p> <p>Decade Manufactured</p> <p>L=0 C=3 F=6 J=9</p> <p>A=1 D=4 G=7</p> <p>B=2 E=5 H=8</p>	L	C	G	R	<p style="font-size: 1.2em; font-weight: bold;">00001</p> <p style="text-align: center;">Production Run Number</p>
<p>Year Manufactured</p> <p>A=1 D=4 G=7 K=0</p> <p>B=2 E=5 H=8</p> <p>C=3 F=6 J=9</p>					<p>Product Line</p> <p>R = RAC</p> <p>P = PTAC</p> <p>E = EAC</p> <p>V = VPAK</p> <p>H = Split</p>
<p>Month Manufactured</p> <p>A=Jan D=Apr G=Jul K=Oct</p> <p>B=Feb E=May H=Aug L=Nov</p> <p>C=Mar F=Jun J=Sept M=Dec</p>					

PERFORMANCE DATA

Model	EVAPORATOR AIR TEMP °F		CONDENSER TEMP °F	DISCHARGE TEMP	SUCTION TEMP	SUPER HEAT	SUB-COOLING	OPERATING PRESSURES		ELECTRICAL RATINGS			R-22 REF. Charge in OZ.	Voltage	BREAKER FUSE 60 Hertz Amps
	Discharge Air	Temp Drop °F						Suction	Discharge	Amps Cool	Amps Heat	Locked Rotor Amps			
Q-Chassis															
XQ05L10-A	54	27	120	150	68	17	19	85	256	4.8	–	28.0	18.3	115	15
XQ06L10-A	55	26	121	157	65	13	27	87	261	5.0	–	24.0	21.0	115	15
XQ08L10-A	52	29	128	167	60	13	33	81	283	6.8	–	36.2	22.1	115	15
XQ10L10-A	50	31	130	176	65	20	29	75	287	9.2	–	44.0	19.2	115	15
XQ12L10-A	51	29	126	166	51	6	30	75	271	11.0	–	56.0	31.0	115	15
EQ08L11-A	52	29	124	173	69	21	29	82	283	6.5	10.7	36.2	20.0	115	15
S-Chassis															
SS08L10-B	56	24	119	154	68	13	26	85	252	6.6	–	36.2	23.0	115	15
KS10L10-A	52	29	117	162	64	15	21	83	244	8.0	–	42.0	26.0	115	15
RS10L10-A	58	23	117	166	68	15	21	83	244	8.0	–	42.0	26.0	115	15
SS10L10-B	57	23	117	166	65	16	23	82	243	7.5	–	42.0	26.0	115	15
KS12L10-A	52	29	122	169	61	13	24	82	266	9.0	–	44.0	26.5	115	15
RS12L10-A	53	27	124	169	62	13	30	82	266	9.3	–	44.0	32.0	115	15
SS12L10-B	53	27	124	169	62	13	30	82	266	9.3	–	44.0	32.0	115	15
KS15L10-A	51	30	125	182	62	16	29	77	278	12.2	–	61.0	29.0	115	15
RS15L10-A	53	27	125	184	62	16	27	77	278	12.3	–	61.0	29.0	115	15
SS14L10-B	53	27	125	184	62	15	27	78	268	12.3	–	61.0	29.2	115	15
KS12L30-A	48	32	129	176	48	34	36	76	287	12.3	–	24.0	31.0	208 / 230	15
SS12L30-B	57	24	121	170	67	17	27	83	258	5.4	–	21.0	28.0	208 / 230	15
SS16L30-B	50	31	130	176	53	8	35	77	279	7.9	–	35.0	32.1	208 / 230	15
RS16L30-A	50	31	130	176	53	8	35	77	279	7.4	–	35.0	32.0	208 / 230	15
ES12L33-A	56	25	121	167	65	15	28	83	256	4.8	15.1	21.0	28.0	208 / 230	20
ES16L33-A	49	32	130	179	50	8	34	75	279	7.4	15.1	35.0	32.0	208 / 230	20
YS09L10-A	60	20	116	164	71	18	17	89	239	7.1	8.5	44.0	25.1	115	15
YS09L10-B	60	20	116	164	71	18	17	89	239	7.1	8.5	44.0	25.1	115	15
YS09L10A-A	60	20	116	164	71	18	17	89	239	7.1	8.5	44.0	25.1	115	15
YS13L33-A	58	23	123	175	69	22	29	79	266	5.2	5.3 / 15.1	24.0	30.0	208 / 230	20
M-Chassis															
KM24L30-A	50	31	132	187	56	14	37	70	287	11.2	–	68.0	53.0	208 / 230	20
RM24L30-A	50	31	132	187	56	14	37	70	287	11.2	–	68.0	53.0	208 / 230	20
YM18L34-A	49	31	125	182	64	22	27	72	271	8.5	8.7 / 18.6	41.0	43.0	208 / 230	30
RM18L30-A	49	31	125	175	63	21	31	72	271	8.7	–	42.0	39.5	208 / 230	15
EM18L34-A	49	31	125	175	63	21	31	72	271	8.1	18.9	42.0	39.5	208 / 230	15
KM18L30-A	49	31	125	175	63	21	31	72	271	8.1	–	42.0	39.5	208 / 230	15
SM18L30-A	53	28	122	175	66	13	25	82	255	7.3	–	37.0	44.0	208 / 230	15
KM21L30-A	50	31	127	185	57	15	34	73	274	9.4	–	43.0	45.0	208 / 230	15
SM21L30-A	50	31	127	185	57	15	34	73	274	9.4	–	43.0	45.0	208 / 230	15
EM24L35	50	31	132	187	56	14	37	70	287	11.2	25.0	68.0	53.0	208 / 230	30
SM24L30	50	31	132	187	56	14	37	70	287	11.2	–	68.0	53.0	208 / 230	20
L-Chassis															
SL28L30-A	53	28	128	172	56	13	29	73	259	13.0	–	68.0	50.1	208 / 230	20
SL36L30-A	49	31	133	192	53	12	37	70	287	17.2	–	91.0	57.6	208 / 230	30
SL36L30-B	49	31	133	192	53	12	37	70	287	17.2	–	91.0	57.6	208 / 230	30
EL36L35-A	49	32	133	194	53	13	38	70	302	18.0	25.0	91.0	60.0	208 / 230	30
YL24L35-A	52	29	122	175	65	23	29	72	262	10.9	11.2 / 24.6	68.0	74.0	208 / 230	30
Casement															
SC06L10-A	47	33	128	166	47	14	23	74	290	6.7	–	40.0	20.0	115	15
HazardGard															
SH15L30-A	54	26	206	129	61	16	98	76	258	8.2	–	–	28.5	208 / 230	15
SH20L30-A	46	34	125	196	52	8	28	75	271	10.1	–	–	39.0	208 / 230	20

ELECTRICAL DATA

Wire Size	Use ONLY wiring size recommended for single outlet branch circuit.
Fuse/Circuit Breaker	Use ONLY type and size fuse or HACR circuit breaker indicated on unit's rating plate. Proper current protection to the unit is the responsibility of the owner.
Grounding	Unit MUST be grounded from branch circuit through service cord to unit, or through separate ground wire provided on permanently connected units. Be sure that branch circuit or general purpose outlet is grounded.
Receptacle	The field supplied outlet must match plug on service cord and be within reach of service cord. Do NOT alter the service cord or plug. Do NOT use an extension cord. Refer to the table above for proper receptacle and fuse type.



ELECTRIC SHOCK HAZARD.

Turn off electric power before service or installation.

All electrical connections and wiring MUST be installed by a qualified electrician and conform to the National Electrical Code and all local codes which have jurisdiction.

Failure to do so can result in property damage, personal injury and/or death.



The consumer - through the AHAM Room Air Conditioner Certification Program - can be certain that the AHAM Certification Seal accurately states the unit's cooling and heating capacity rating, the amperes and the energy efficiency ratio.

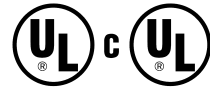

FUNCTIONAL COMPONENT DEFINITIONS

MECHANICAL COMPONENTS

Bellows condensate valve Temperature-sensitive valve that opens up to drain off condensate water when the outside temperature falls below 40°F and closes when the outside temperature reaches 58°F.

Vent door Allows introduction of fresh air into the room and/or exhausts stale room air outside (on select models.)

Plenum assembly Diffuser with directional louvers used to direct the conditioned airflow.

Blower wheel Attaches to the indoor side of the fan motor shaft and is used for distributing unconditioned, room side air through the heat exchanger and delivering conditioned air into the room.

Slinger fan blade Attaches to the outdoor side of the fan motor shaft and is used to move outside air through the condenser coil, while slinging condensate water out of the base pan and onto the condenser coil, thus lowering the temperature and pressures within the coil.

ELECTRICAL COMPONENTS

Thermostat Used to maintain the specified room side comfort level

System switch Used to regulate the operation of the fan motor, the compressor or to turn the unit off. For troubleshooting, refer to the wiring diagrams and schematics in the back of this service manual.

Capacitor Reduces line current and steadies the voltage supply, while greatly improving the torque characteristics of the fan motor and compressor motor.

ELECTRICAL COMPONENTS cont'd

MoneySaver® switch When engaged, it sends the power supply to the fan motor through the thermostat, which allows for a cycle-fan operation.

Fan Motor Dual-shafted fan motor operates the indoor blower wheel and the condenser fan blade simultaneously.

Solenoid Used to energize the reversing valve on all heat pump units.

Heating element Electric resistance heater, available in 3.3, 4.0 or 5.2 kW on select TwinTemp® models.

Heat anticipator Used to provide better thermostat and room air temperature control.

HERMETIC COMPONENTS

Compressor Motorized device used to compress refrigerant through the sealed system.

Reversing valve A four-way switching device used on all heat pump models to change the flow of refrigerant to permit heating or cooling.

Check valve A pressure-operated device used to direct the flow of refrigerant to the proper capillary tube, during either the heating or cooling cycle.

Capillary tube A cylindrical meter device used to evenly distribute the flow of refrigerant to the heat exchangers (coils.)

ELECTRONIC CONTROLS

TESTING THE ELECTRONIC CONTROLS

CHECK FILTER light will come on after 250 hours of use. Touch **CHECK FILTER** to reset.

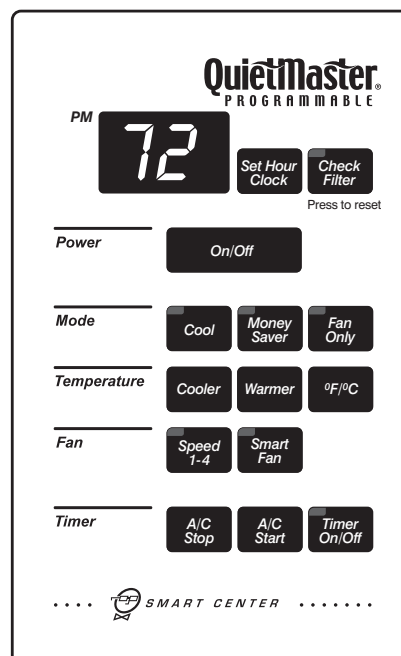

Electronic Control

ELECTRONIC CONTROLS

TESTING THE ELECTRONIC CONTROL XQ/WS BOARDS & QME BOARDS

Activating Test Mode: Activate test mode by pressing at the same time the “**MODE**” button and the temperature “**DOWN**” button on **XQ & WS models**. LEDs for Hour, Start, and Stop will blink 1 bps while Test Mode is active.

Activate test mode by pressing at the same time the “**MONEY SAVER**” button and the “**CHECK FILTER**” button on **QME models**. LED for the Filter Alert will blink 1 bps while Test Mode is active.

Test Mode has duration of 90 minutes. Test Mode can be activated under any conditions, including Off. Test Mode is cancelled by pressing the On/Off button, unplugging the unit, or when the 90 minutes is timed out. All settings revert to the factory default settings of Cool, 75° F, Timer and Set Hour features are nonfunctional.

Test Mode overrides the three-minute lockout, all delays for compressor and fan motor start / speed change, and no delay when switching modes.

Test Mode default settings are ON, Money Saver, 60° F, and High fan speed.

Activating Error Code Mode: (Submode of Test Mode) Unit must be in Test Mode to enter Error Code Mode

Activate Error Code Mode by pressing the “**TIMER ON/OFF**” button on XQ & WS models. LED for the “**TIMER ON/OFF**” will flash 1 bps while Error Code Mode is active. Pressing the “**TEMP/HR +**” button will display 00. Consecutive presses will scroll through all error codes logged. Press the “**TEMP/HR -**” button to see the reverse order of all error codes logged. When the end of logged error codes is reached the temperature set point will appear.

Activate Error Code Mode by pressing at the same time the “**A/C START**” button and the “**ON/OFF**” button on QME models. LED for the “**TIMER ON/OFF**” will flash 1 bps while Error Code Mode is active. Pressing the “**WARMER**” button will display 00. Consecutive presses will scroll through all error codes logged. Press the “**COOLER**” button to see the reverse order of all error codes logged. When the end of logged error codes is reached the temperature set point will appear.

TESTING THE ELECTRONIC CONTROL ERROR CODE LISTINGS

IMPORTANT: Error Codes are cleared from the log by exiting from Error Code Mode. To exit on XQ models, press Timer On/Off button. To exit QME models, press A/C Start and On/Off buttons. Or unplug unit to exit Error Code Mode. Plug unit in after 5 seconds to resume normal operation of unit.

TESTING THE ELECTRONIC CONTROL ERROR CODE LISTINGS

E1 SHORT CYCLE SITUATION: Keyboard is fine. Investigate and define short cycling problem.

E2 KEYBOARD STUCK ERROR: If key button(s) are pressed continuously for twenty seconds or more. If MODE key is stuck, unit will default to cool. Exit Error Code Mode to see if error “E2” is no longer displayed and unit is functioning. Replace board if “E2” still displays after exiting Error Code Mode.

E3 FROST PROBE OPEN: If ohm value is present, replace board.

E4 FROST PROBE SHORT: Replace board.

E5 INDOOR PROBE OPEN: Replace board.

E6 INDOOR PROBE SHORT: Replace board.

NOTE: All Error Code displays for Frost & Indoor Probe will allow unit to operate. Unit may or will ice up if faulty components not replaced.

FROST PROBE SENSOR: disables compressor at 35° F.

INDOOR PROBE SENSOR: Control range is 60° F to 90° F +/- 2° F.

Indoor temperature will be displayed by pressing:

(QME units) The **Fan Speed** button and the **Warmer** button.

(XQ units) The **Fan Speed** button and the **Temp Up** button.

The indoor temperature will be displayed for 10 seconds. The display will change back to the Set Point temperature by pressing any key button except for the On/Off button. The indoor temperature can be viewed in all modes, including test mode.

Check Filter: The **Check Filter** indicator turns on after the fan motor has been operating for 250 hours. The **Check Filter** indicator is reset by pressing the **Check Filter** button one time only,. Power failures will not reset the 250 hour timer. All time elapsed is stored in memory and resumes counting after power is restored.

Keep Alive: The electronic control has a memory to retain all functions and status as set up by the user in the event of a power failure. Once power is restored to the unit there is a two second delay before the fan comes on and approximately three minutes delay before the compressor is activated, providing that the mode was set for cooling and the set point temperature has not been met in the room.

REFRIGERATION SYSTEM SEQUENCE OF OPERATION

A good understanding of the basic operation of the refrigeration system is essential for the service technician. Without this understanding, accurate troubleshooting of refrigeration system problems will be more difficult and time consuming, if not (in some cases) entirely impossible. The refrigeration system uses four basic principles (laws) in its operation they are as follows:

1. "Heat always flows from a warmer body to a cooler body."
2. "Heat must be added to or removed from a substance before a change in state can occur"
3. "Flow is always from a higher pressure area to a lower pressure area."
4. "The temperature at which a liquid or gas changes state is dependent upon the pressure."

The refrigeration cycle begins at the compressor. Starting the compressor creates a low pressure in the suction line which draws refrigerant gas (vapor) into the compressor. The compressor then "compresses" this refrigerant, raising its pressure and its (heat intensity) Temperature.

The refrigerant leaves the compressor through the discharge line as a hot high pressure gas (vapor). The refrigerant enters the condenser coil where it gives up some of its heat. The condenser fan moving air across the coil's finned surface facilitates the transfer of heat from the refrigerant to the relatively cooler outdoor air.

When a sufficient quantity of heat has been removed from the refrigerant gas (vapor), the refrigerant will "condense" (i.e. change to a liquid). Once the refrigerant has been condensed (changed) to a liquid it is cooled even further by the air that continues to flow across the condenser coil.

The RAC design determines at exactly what point (in the condenser) the change of state (i.e. gas to a liquid) takes place. In all cases, however, the refrigerant must be totally condensed (changed) to a liquid before leaving the condenser coil.

The refrigerant leaves the condenser coil through the liquid line as a warm high pressure liquid. It next will pass through the refrigerant drier (if so equipped). It is the function of the drier to trap any moisture present in the system, contaminants, and large particulate matter.

The liquid refrigerant next enters the metering device. The metering device is a capillary tube. The purpose of the metering device is to "meter" (i.e. control or measure) the quantity of refrigerant entering the evaporator coil.

In the case of the capillary tube this is accomplished (by design) through size (and length) of device, and the pressure difference present across the device.

Since the evaporator coil is under a lower pressure (due to the suction created by the compressor) than the liquid line,

the liquid refrigerant leaves the metering device entering the evaporator coil. As it enters the evaporator coil, the larger area and lower pressure allows the refrigerant to expand and lower its temperature (heat intensity). This expansion is often referred to as "boiling". Since the unit's blower is moving Indoor air across the finned surface of the evaporator coil, the expanding refrigerant absorbs some of that heat. This results in a lowering of the indoor air temperature, hence the "cooling" effect.

The expansion and absorbing of heat cause the liquid refrigerant to evaporate (i.e. change to a gas). Once the refrigerant has been evaporated (changed to a gas), it is heated even further by the air that continues to flow across the evaporator coil.

The particular system design determines at exactly what point (in the evaporator) the change of state (i.e. liquid to a gas) takes place. In all cases, however, the refrigerant must be totally evaporated (changed) to a gas before leaving the evaporator coil.

The low pressure (suction) created by the compressor causes the refrigerant to leave the evaporator through the suction line as a cool low pressure vapor. The refrigerant then returns to the compressor, where the cycle is repeated.

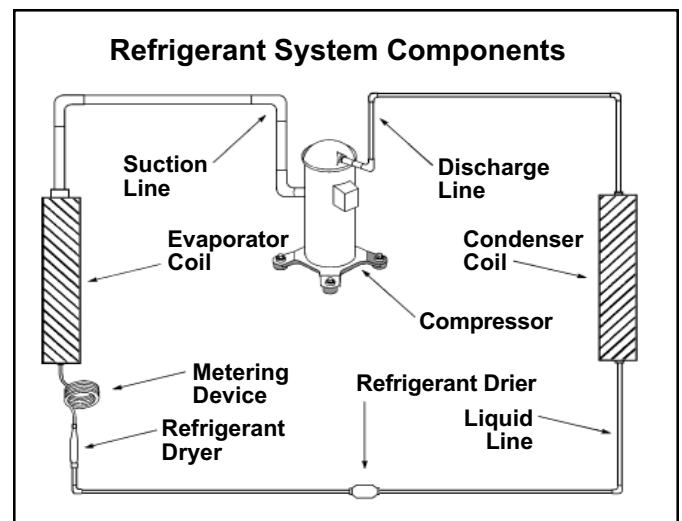

SEALED REFRIGERATION SYSTEM REPAIRS

IMPORTANT

ANY SEALED SYSTEM REPAIRS TO COOL-ONLY MODELS REQUIRE THE INSTALLATION OF A LIQUID LINE DRIER. ALSO, ANY SEALED SYSTEM REPAIRS TO HEAT PUMP MODELS REQUIRE THE INSTALLATION OF A SUCTION LINE DRIER.

EQUIPMENT REQUIRED

1. Voltmeter
2. Ammeter
3. Ohmmeter
4. E.P.A. Approved Refrigerant Recovery System.
5. Vacuum Pump (capable of 200 microns or less vacuum.)
6. Acetylene Welder
7. Electronic Halogen Leak Detector (G.E. Type H-6 or equivalent.)
8. Accurate refrigerant charge measuring device such as:
 - a. Balance Scales - 1/2 oz. accuracy
 - b. Charging Board - 1/2 oz. accuracy
9. High Pressure Gauge - (0 - 400 lbs.)
10. Low Pressure Gauge - (30 - 150 lbs.)
11. Vacuum Gauge - (0 - 1000 microns)

EQUIPMENT MUST BE CAPABLE OF:

1. Recovery CFC's as low as 5%.
2. Evacuation from both the high side and low side of the system simultaneously.
3. Introducing refrigerant charge into high side of the system.
4. Accurately weighing the refrigerant charge actually introduced into the system.
5. Facilities for flowing nitrogen through refrigeration tubing during all brazing processes.

HERMETIC COMPONENT REPLACEMENT

The following procedure applies when replacing components in the sealed refrigeration circuit or repairing refrigerant leaks. (Compressor, condenser, evaporator, capillary tube, refrigerant leaks, etc.)

1. Recover the refrigerant from the system at the process tube located on the high side of the system by installing a line tap on the process tube. Apply gauge from process tube to EPA approved gauges from process tube to EPA approved recovery system. Recover CFC's in system to at least 5%.
2. Cut the process tube below pinch off on the suction side of the compressor.
3. Connect the line from the nitrogen tank to the suction process tube.
4. Drift dry nitrogen through the system and un-solder the more distant connection first. (Filter drier, high side process tube, etc.)
5. Replace inoperative component, and always install a new filter drier. Drift dry nitrogen through the system when making these connections.

HERMETIC COMPONENT REPLACEMENT cont'd

6. Pressurize system to 30 PSIG with proper refrigerant and boost refrigerant pressure to 150 PSIG with dry nitrogen.
 7. Leak test complete system with electric halogen leak detector, correcting any leaks found.
 8. Reduce the system to zero gauge pressure.
 9. Connect vacuum pump to high side and low side of system with deep vacuum hoses, or copper tubing. (Do not use regular hoses.)
 10. Evacuate system to maximum absolute holding pressure of 200 microns or less. NOTE: This process can be accelerated by use of heat lamps, or by breaking the vacuum with refrigerant or dry nitrogen at 5,000 microns. Pressure system to 5 PSIG and leave in system a minimum of 10 minutes. Release refrigerant, and proceed with evacuation of a pressure of 200 microns or less.
 11. Break vacuum by charging system from the high side with the correct amount of liquid refrigerant specified. This will prevent boiling the oil out of the crankcase, and damage to the compressor due to over heating.
- NOTE:** If the entire charge will not enter the high side, allow the remainder to enter the low side in small increments while operating the unit.
12. Restart unit several times after allowing pressures to stabilize. Pinch off process tubes, cut and solder the ends. Remove pinch off tool, and leak check the process tube ends.

SPECIAL PROCEDURE IN THE CASE OF COMPRESSOR MOTOR BURNOUT

1. Recover all refrigerant and oil from the system.
2. Remove compressor, capillary tube and filter drier from the system.
3. Flush evaporator condenser and all connecting tubing with dry nitrogen or equivalent, to remove all contamination from system. Inspect suction and discharge line for carbon deposits. Remove and clean if necessary.
4. Reassemble the system, including new drier strainer and capillary tube.
5. Proceed with processing as outlined under hermetic component replacement.

ROTARY COMPRESSOR SPECIAL TROUBLESHOOTING AND SERVICE

Basically, troubleshooting and servicing rotary compressors is the same as on the reciprocating compressor with only one main exception:

NEVER, under any circumstances, charge a rotary compressor through the LOW side. Doing so would cause permanent damage to the new compressor.

REFRIGERANT CHARGING

NOTE: BECAUSE THE RAC SYSTEM IS A SEALED SYSTEM, SERVICE PROCESS TUBES WILL HAVE TO BE INSTALLED. FIRST INSTALL A LINE TAP AND REMOVE REFRIGERANT FROM SYSTEM. MAKE NECESSARY SEALED SYSTEM REPAIRS AND VACUUM SYSTEM. CRIMP PROCESS TUBE LINE AND SOLDER END SHUT. DO NOT LEAVE A SERVICE VALVE IN THE SEALED SYSTEM.

Proper refrigerant charge is essential to proper unit operation. Operating a unit with an improper refrigerant charge will result in reduced performance (capacity) and/or efficiency. Accordingly, the use of proper charging methods during servicing will insure that the unit is functioning as designed and that its compressor will not be damaged.

Too much refrigerant (overcharge) in the system is just as bad (if not worse) than not enough refrigerant (undercharge). They both can be the source of certain compressor failures if they remain uncorrected for any period of time. Quite often, other problems (such as low air flow across evaporator, etc.) are misdiagnosed as refrigerant charge problems. The refrigerant circuit diagnosis chart will assist you in properly diagnosing these systems.

An overcharged unit will at times return liquid refrigerant (slugging) back to the suction side of the compressor eventually causing a mechanical failure within the compressor. This mechanical failure can manifest itself as valve failure, bearing failure, and/or other mechanical failure. The specific type of failure will be influenced by the amount of liquid being returned, and the length of time the slugging continues.

Not enough refrigerant (Undercharge) on the other hand, will cause the temperature of the suction gas to increase to the point where it does not provide sufficient cooling for the

compressor motor. When this occurs, the motor winding temperature will increase causing the motor to overheat and possibly cycle open the compressor overload protector. Continued overheating of the motor windings and/or cycling of the overload will eventually lead to compressor motor or overload failure.

METHOD OF CHARGING

The acceptable method for charging the RAC system is the Weighed in Charge Method. The weighed in charge method is applicable to all units. It is the preferred method to use, as it is the most accurate.

The weighed in method should always be used whenever a charge is removed from a unit such as for a leak repair, compressor replacement, or when there is no refrigerant charge left in the unit. To charge by this method, requires the following steps:

1. Install a piercing valve to remove refrigerant from the sealed system. (Piercing valve must be removed from the system before recharging.)
2. Recover Refrigerant in accordance with EPA regulations.
3. Install a process tube to sealed system.
4. Make necessary repairs to system.
5. Evacuate system to 250 - 300 microns or less.
6. Weigh in refrigerant with the property quantity of R-22 refrigerant.
7. Start unit, and verify performance.
8. Crimp the process tube and solder the end shut.

NOTE: In order to access the sealed system it will be necessary to install Schrader type fittings to the process tubes on the discharge and suction of the compressor. Proper refrigerant recovery procedures need to be adhered to as outlined in EPA Regulations. THIS SHOULD ONLY BE ATTEMPTED BY QUALIFIED SERVICE PERSONNEL.

REFRIGERANT CHARGING cont'd

UNDERCHARGED REFRIGERANT SYSTEMS

An undercharged system will result in poor performance (low pressures, etc.) in both the heating and cooling cycle.

Whenever you service a unit with an undercharge of refrigerant, always suspect a leak. The leak must be repaired before charging the unit.

To check for an undercharged system, turn the unit on, allow the compressor to run long enough to establish working pressures in the system (15 to 20 minutes).

During the cooling cycle you can listen carefully at the exit of the metering device into the evaporator; an intermittent hissing and gurgling sound indicates a low refrigerant charge.

Intermittent frosting and thawing of the evaporator is another indication of a low charge, however, frosting and thawing can also be caused by insufficient air over the evaporator.

Checks for an undercharged system can be made at the compressor. If the compressor seems quieter than normal, it is an indication of a low refrigerant charge. A check of the amperage drawn by the compressor motor should show a lower reading. (Check the Unit Specification.) After the unit has run 10 to 15 minutes, check the gauge pressures.

Gauges connected to system with an undercharge will have low head pressures and substantially low suction pressures.

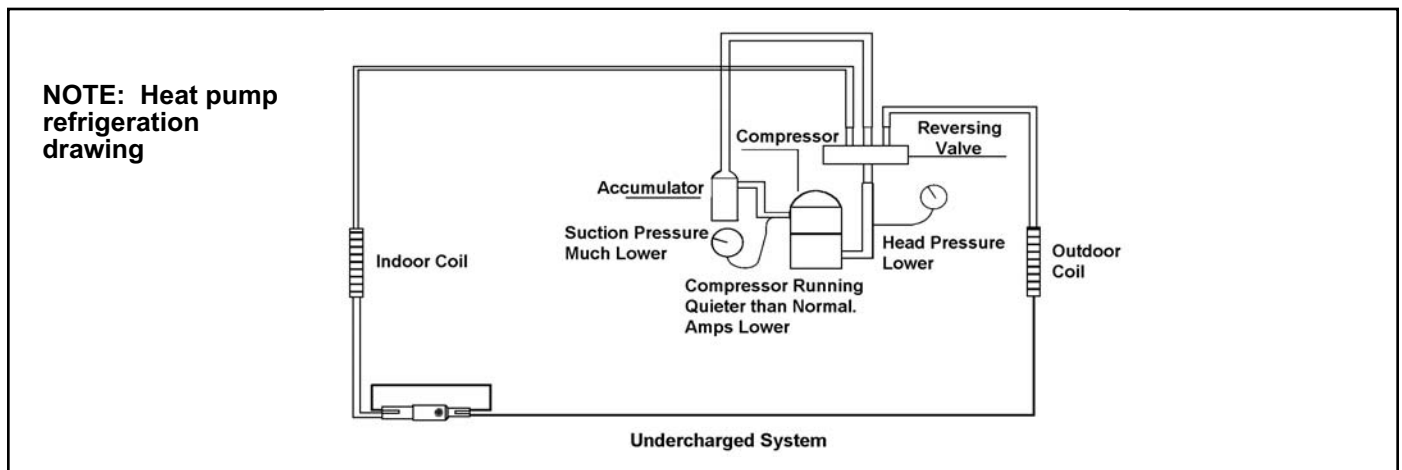

OVERCHARGED REFRIGERANT SYSTEMS

Compressor amps will be near normal or higher. Noncondensables can also cause these symptoms. To confirm, remove some of the charge, if conditions improve, system may be overcharged. If conditions don't improve, Noncondensables are indicated.

Whenever an overcharged system is indicated, always make sure that the problem is not caused by air flow problems. Improper air flow over the evaporator coil may indicate some of the same symptoms as an overcharged system.

An over charge can cause the compressor to fail, since it would be "slugged" with liquid refrigerant.

The charge for any system is critical. When the compressor is noisy, suspect an overcharge, when you are sure that the air quantity over the evaporator coil is correct. Icing of the evaporator will not be encountered because the refrigerant will boil later if at all. Gauges connected to system will usually have higher head pressure (depending upon amount of overcharge). Suction pressure should be slightly higher.

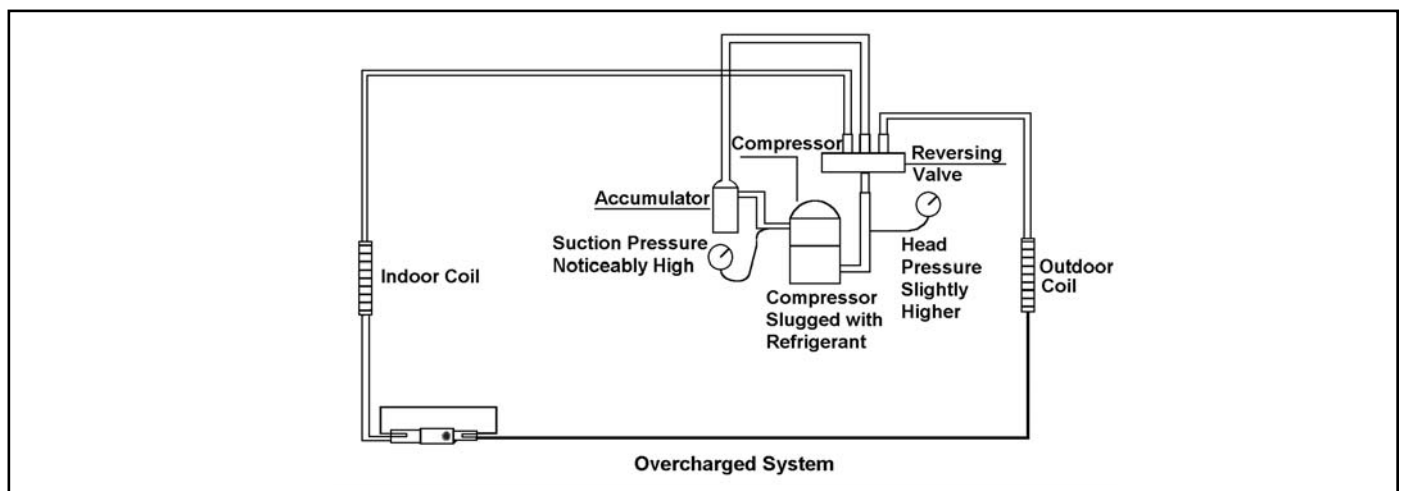

REFRIGERANT CHARGING cont'd

RESTRICTED REFRIGERANT SYSTEM

A quick check for either condition begins at the evaporator. With a partial restriction, there may be gurgling sounds at the metering device entrance to the evaporator. The evaporator in a partial restriction could be partially frosted or have an ice ball close to the entrance of the metering device. Frost may continue on the suction line back to the compressor.

Often a partial restriction of any type can be found by feel, as there is a temperature difference from one side of the restriction to the other.

With a complete restriction, there will be no sound at the metering device entrance. An amperage check of the compressor with a partial restriction may show normal current when compared to the unit specification. With a complete restriction the current drawn may be considerably less than normal, as the compressor is running in a deep vacuum (no load). Much of the area of the condenser will be relatively cool since most or all of the liquid refrigerant will be stored there.

The following conditions are based primarily on a system in the cooling mode.

Troubleshooting a restricted refrigerant system can be difficult. The following procedures are the more common problems and solutions to these problems. There are two types of refrigerant restrictions: Partial restrictions and complete restrictions.

- A partial restriction allows some of the refrigerant to circulate through the system.
- With a complete restriction there is no circulation of refrigerant in the system.
- Restricted refrigerant systems display the same symptoms as a "low-charge condition."
- When the unit is shut off, the gauges may equalize very slowly.
- Gauges connected to a completely restricted system will run in a deep vacuum. When the unit is shut off, the gauges will not equalize at all.

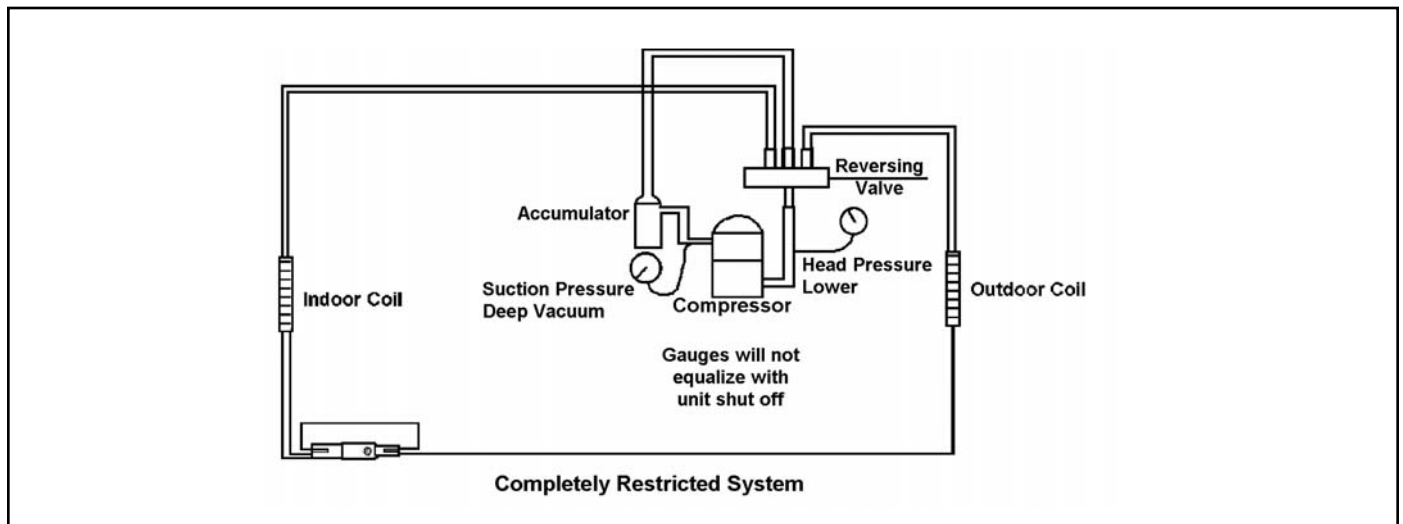
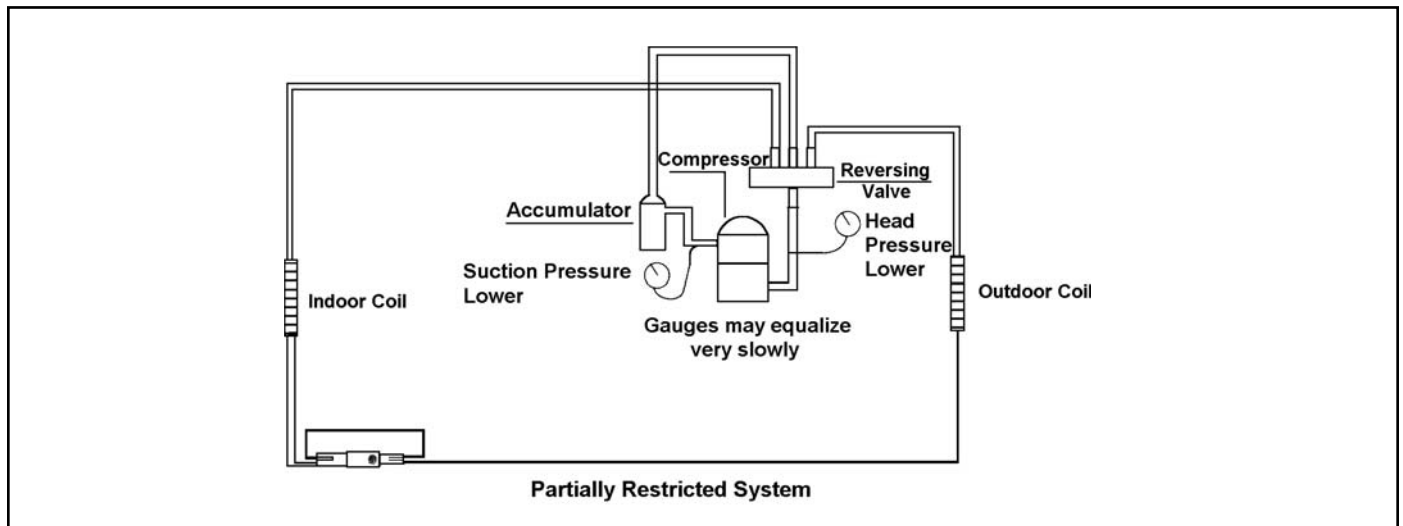

TROUBLESHOOTING TOUCH TEST CHART: TO SERVICE REVERSING VALVES

NORMAL FUNCTION OF VALVE								
VALVE OPERATING CONDITION	DISCHARGE TUBE from Compressor	SUCTION TUBE to Compressor	Tube to INSIDE COIL	Tube to OUTSIDE COIL	LEFT Pilot Capillary Tube	RIGHT Pilot Capillary Tube	NOTES:	
	1	2	3	4	5	6	POSSIBLE CAUSES	CORRECTIONS
Normal Cooling	Hot	Cool	Cool as (2)	Hot as (1)	*TVB	TVB		
Normal Heating	Hot	Cool	Hot as (1)	Cool as (2)	*TVB	TVB		
MALFUNCTION OF VALVE								
Valve will not shift from cool to heat.	Check Electrical circuit and coil						No voltage to coil.	Repair electrical circuit.
							Defective coil.	Replace coil.
	Check refrigeration charge						Low charge.	Repair leak, recharge system.
							Pressure differential too high.	Recheck system.
	Hot	Cool	Cool, as (2)	Hot, as (1)	*TVB	Hot	Pilot valve okay. Dirt in one bleeder hole.	De-energize solenoid, raise head pressure, reenergize solenoid to break dirt loose. If unsuccessful, remove valve, wash out. Check on air before installing. If no movement, replace valve, add strainer to discharge tube, mount valve horizontally.
						Piston cup leak	Stop unit. After pressures equalize, restart with solenoid energized. If valve shifts, reattempt with compressor running. If still no shift, replace valve.	
Valve will not shift from cool to heat.	Hot	Cool	Cool, as (2)	Hot, as (1)	*TVB	*TVB	Clogged pilot tubes.	Raise head pressure, operate solenoid to free. If still no shift, replace valve.
	Hot	Cool	Cool, as (2)	Hot, as (1)	Hot	Hot	Both ports of pilot open. (Back seat port did not close).	Raise head pressure, operate solenoid to free partially clogged port. If still no shift, replace valve.
	Warm	Cool	Cool, as (2)	Hot, as (1)	*TVB	Warm	Defective Compressor.	Replace compressor
Starts to shift but does not complete reversal.	Hot	Warm	Warm	Hot	*TVB	Hot	Not enough pressure differential at start of stroke or not enough flow to maintain pressure differential.	Check unit for correct operating pressures and charge. Raise head pressure. If no shift, use valve with smaller port.
							Body damage.	Replace valve
	Hot	Warm	Warm	Hot	Hot	Hot	Both ports of pilot open.	Raise head pressure, operate solenoid. If no shift, use valve with smaller ports.
	Hot	Hot	Hot	Hot	*TVB	Hot	Body damage.	Replace valve
							Valve hung up at mid-stroke. Pumping volume of compressor not sufficient to maintain reversal.	Raise head pressure, operate solenoid. If no shift, use valve with smaller ports.
	Hot	Hot	Hot	Hot	Hot	Hot	Both ports of pilot open.	Raise head pressure, operate solenoid. If no shift, replace valve.
Apparent leap in heating.	Hot	Cool	Hot, as (1)	Cool, as (2)	*TVB	*TVB	Piston needle on end of slide leaking.	Operate valve several times, then recheck. If excessive leak, replace valve.
	Hot	Cool	Hot, as (1)	Cool, as (2)	** WVB	** WVB	Pilot needle and piston needle leaking.	Operate valve several times, then recheck. If excessive leak, replace valve.
Will not shift from heat to cool.	Hot	Cool	Hot, as (1)	Cool, as (2)	*TVB	*TVB	Pressure differential too high.	Stop unit. Will reverse during equalization period. Recheck system
							Clogged pilot tube.	Raise head pressure, operate solenoid to free dirt. If still no shift, replace valve.
	Hot	Cool	Hot, as (1)	Cool, as (2)	Hot	*TVB	Dirt in bleeder hole.	Raise head pressure, operate solenoid. Remove valve and wash out. Check on air before reinstalling, if no movement, replace valve. Add strainer to discharge tube. Mount valve horizontally.
	Hot	Cool	Hot, as (1)	Cool, as (2)	Hot	*TVB	Piston cup leak.	Stop unit. After pressures equalize, restart with solenoid de-energized. If valve shifts, reattempt with compressor running. If it still will not reverse while running, replace the valve.
	Hot	Cool	Hot, as (1)	Cool, as (2)	Hot	Hot	Defective pilot.	Replace valve.
	Warm	Cool	Warm, as (1)	Cool, as (2)	Warm	*TVB	Defective compressor.	Replace compressor

COOLING ONLY ROOM AIR CONDITIONERS: TROUBLESHOOTING TIPS

Problem	Possible Cause	Action
Compressor does not run	Low voltage	Check voltage at compressor. 115V & 230V units will operate at 10% voltage variance
	T-stat not set cold enough or inoperative	Set t-stat to coldest position. Test t-stat & replace if inoperative
	Compressor hums but cuts off on B10 overload	Hard start compressor. Direct test compressor. If compressor starts, add starting components
	Open or shorted compressor windings	Check for continuity & resistance
	Open overload	Test overload protector & replace if inoperative
	Open capacitor	Test capacitor & replace if inoperative
	Inoperative system switch	Test for continuity in all positions. Replace if inoperative
	Broken, loose or incorrect wiring	Refer to appropriate wiring diagrams to check wiring

Problem	Possible Cause	Action
Fan motor does not run	Inoperative system switch	Test switch & replace if inoperative
	Broken, loose or incorrect wiring	Refer to applicable wiring diagram
	Open capacitor	Test capacitor & replace if inoperative
	Fan speed switch open	Test switch & replace if inoperative
	Inoperative fan motor	Test fan motor & replace if inoperative (be sure internal overload has had time to reset)

Problem	Possible Cause	Action
Does not cool or only cools slightly	Undersized unit	Refer to industry standard sizing chart
	T-stat open or inoperative	Set to coldest position. Test t-stat & replace if necessary
	Dirty filter	Clean as recommended in Owner's Manual
	Dirty or restricted condenser or evaporator coil	Use pressure wash or biodegradable cleaning agent to clean
	Poor air circulation	Adjust discharge louvers. Use high fan speed
	Fresh air or exhaust air door open on applicable models	Close doors. Instruct customer on use of this feature
	Low capacity - undercharge	Check for leak & make repair
	Compressor not pumping properly	Check amperage draw against nameplate. If not conclusive, make pressure test

Problem	Possible Cause	Action
Unit does not run	Fuse blown or circuit tripped	Replace fuse, reset breaker. If repeats, check fuse or breaker size. Check for shorts in unit wiring & components
	Power cord not plugged in	Plug it in
	System switch in "OFF" position	Set switch correctly
	Inoperative system switch	Test for continuity in each switch position
	Loose or disconnected wiring at switch or other components	Check wiring & connections. Reconnect per wiring diagram

Problem	Possible Cause	Action
Evaporator coil freezes up	Dirty filter	Clean as recommended in Owner's Manual
	Restricted airflow	Check for dirty or obstructed coil. Use pressure wash or biodegradable cleaning agent to clean
	Inoperative t-stat	Test for shorted t-stat or stuck contacts
	Short of refrigerant	De-ice coil & check for leak
	Inoperative fan motor	Test fan motor & replace if inoperative
	Partially restricted capillary tube	De-ice coil. Check temp. differential (delta T) across coil. Touch test coil return bends for same temp. Test for low running current

Problem	Possible Cause	Action
Compressor runs continually & does not cycle off	Excessive heat load	Unit undersized. Test cooling performance & replace with larger unit if needed
	Restriction in line	Check for partially iced coil & check temperature split across coil
	Refrigerant leak	Check for oil at silver soldered connections. Check for partially iced coil. Check split across coil. Check for low running amperage
	T-stat contacts stuck	Check operation of t-stat. Replace if contacts remain closed.
	T-stat incorrectly wired	Refer to appropriate wiring diagram

Problem	Possible Cause	Action
T-stat does not turn unit off	T-stat contacts stuck	Disconnect power to unit. Remove cover of t-stat & check if contacts are stuck. If so, replace t-stat
	T-stat set at coldest point	Turn to higher temp. setting to see if unit cycles off
	Incorrect wiring	Refer to appropriate wiring diagrams
	Unit undersized for area to be cooled	Refer to industry standard sizing chart

Problem	Possible Cause	Action
Compressor runs for short periods only. Cycles on overload	Overload inoperative. Opens too soon	Check operation of unit. Replace overload if system operation is satisfactory
	Compressor restarted before system pressures equalized	Allow a minimum of 2 minutes to allow pressures to equalize before attempting to restart. Instruct customer of waiting period
	Low or fluctuating voltage	Check voltage with unit operating. Check for other appliances on circuit. Air conditioner should be in separate circuit for proper voltage & fused separately
	Incorrect wiring	Refer to appropriate wiring diagram
	Shorted or incorrect capacitor	Check by substituting a known good capacitor of correct rating
	Restricted or low air flow through condenser coil	Check for proper fan speed or blocked condenser
	Compressor running abnormally hot	Check for kinked discharge line or restricted condenser. Check amperage

Problem	Possible Cause	Action
T-stat does not turn unit on	Loss of charge in t-stat bulb	Place jumper across t-stat terminals to check if unit operates. If unit operates, replace t-stat.
	Loose or broken parts in t-stat	Check as above
	Incorrect wiring	Refer to appropriate wiring diagram

Problem	Possible Cause	Action
Noisy operation	Poorly installed	Refer to Installation Manual for proper installation
	Fan blade striking chassis	Reposition - adjust motor mount
	Compressor vibrating	Check that compressor grommets have not deteriorated. Check that compressor mounting parts are not missing
	Improperly mounted or loose cabinet parts	Check assembly & parts for looseness, rubbing & rattling

Problem	Possible Cause	Action
Water leaks into the room	Evaporator drain pan overflowing	Clean obstructed drain trough
	Condensation forming on base pan	Evaporator drain pan broken or cracked. Reseal or replace
	Poor installation resulting in rain entering the room	Check installation instructions. Reseal as required
	Condensation on discharge grille louvers	Clean the dirty evaporator coil. Use pressure wash or biodegradable cleaning agent to clean
	Chassis gasket not installed	Install gasket, per Installation manual
	Downward slope of unit is too steep	Refer to installation manual for proper installation

Problem	Possible Cause	Action
Water "spitting" into room	Sublimation: When unconditioned saturated, outside air mixes with conditioned air, condensation forms on the cooler surfaces	Ensure that foam gaskets are installed in between window panes & in between the unit & the sleeve. Also, ensure that fresh air/exhaust vents (on applicable models) are in the closed position & are in tact
	Downward pitch of installation is too steep	Follow installation instructions to ensure that downward pitch of installed unit is no less than 1/4" & no more than 3/8"
	Restricted coil or dirty filter	Clean & advise customer of periodic cleaning & maintenance needs of entire unit

Problem	Possible Cause	Action
Excessive moisture	Insufficient air circulation thru area to be air conditioned	Adjust louvers for best possible air circulation
	Oversized unit	Operate in "MoneySaver" position
	Inadequate vapor barrier in building structure, particularly floors	Advise customer

Problem	Possible Cause	Action
T-stat short cycles	T-stat differential too narrow	Replace t-stat
	Plenum gasket not sealing, allowing discharge air to short cycle t-stat	Check gasket. Reposition or replace as needed
	Restricted coil or dirty filter	Clean & advise customer of periodic cleaning & maintenance needs of entire unit

Problem	Possible Cause	Action
Prolonged off cycles (automatic operation)	Anticipator (resistor) wire disconnected at t-stat or system switch	Refer to appropriate wiring diagram
	Anticipator (resistor) shorted or open	Disconnect plus from outlet. Remove resistor from bracket. Insert plug & depress "COOL" & "FAN AUTOMATIC" buttons. Place t-stat to warmest setting. Feel resistor for temperature. If no heat, replace resistor
	Partial loss of charge in t-stat bulb causing a wide differential	Replace t-stat

Problem	Possible Cause	Action
Outside water leaks	Evaporator drain pan cracked or obstructed	Repair, clean or replace as required
	Water in compressor area	Detach shroud from pan & coil. Clean & remove old sealer. Reseal, reinstall & check
	Obstructed condenser coil	Use pressure wash or biodegradable cleaning agent to clean
	Fan blade/slinger ring improperly positioned	Adjust fan blade to 1/2" of condenser coil

HEAT / COOL ROOM AIR CONDITIONERS: TROUBLESHOOTING TIPS

Problem	Possible Cause	Action
Room temperature uneven (Heating cycle)	Heat anticipator (resistor) shorted (on applicable models)	Disconnect power to unit. Remove resistor from t-stat bulb block. Plus in unit & allow to operate. Feel resistor for heat. If not heat, replace resistor
	Wide differential - partial loss of t-stat bulb charge	Replace t-stat & check
	Incorrect wiring	Refer to appropriate wiring diagram. Resistor is energized during "ON" cycle of compressor or fan.

Problem	Possible Cause	Action
Unit will not defrost	Incorrect wiring	Refer to appropriate wiring diagram
	Defrost control timer motor not advancing (applicable models)	Check for voltage at "TM" & "TM1" on timer. If no voltage, replace control
	Defrost control out of calibration (applicable models)	If outside coil temperature is 25F or below, & preselected time limit has elapsed, replace defrost control
	Defrost control contacts stuck	If contacts remain closed between terminals "2" & "3" of the defrost control after preselected time interval has passed, replace control
	Defrost control bulb removed from or not making good coil contact	Reinstall & be assured that good bulb to coil contact is made

Problem	Possible Cause	Action
Does not heat adequately	Exhaust or fresh air door open	Check if operating properly. Instruct customer on proper use of control
	Dirty filter	Clean as recommended in Owner's Manual
	Unit undersized	Check heat rise across coil. If unit operates efficiently, check if insulation can be added to attic or walls. If insulation is adequate, recommend additional unit or larger one
	Outdoor t-stat open (applicable models)	T-stat should close at 38°F. Check continuity of control. If temperature is below 38°F, replace control
	Heater hi-limit control cycling on & off	Check for adequate fan air across heater. Check control for open at 160°F & close at 150°F
	Shorted supplementary heater	Ohmmeter check, approx. 32-35 ohms
	Incorrect wiring	Check applicable wiring diagram

Problem	Possible Cause	Action
Unit cools when heat is called for	Incorrect wiring	Refer to applicable wiring diagram
	Defective solenoid coil	Check for continuity of coil
	Reversing valve fails to shift	Block condenser coil & switch unit to cooling. Allow pressure to build up in system, then switch to heating. If valve fails to shift, replace valve.
	Inoperative system switch	Check for continuity of system switch

Problem	Possible Cause	Action
Cooling adequate, but heating insufficient	Heating capillary tube partially restricted	Check for partially starved outer coil. Replace heating capillary tube
	Check valve leaking internally	Switch unit several times from heating to cooling. Check temperature rise across coil. Refer to specification sheet for correct temperature rise
	Reversing valve failing to shift completely; bypassing hot gas	De-energize solenoid coil, raise head pressure, energize solenoid to break loose. If valve fails to make complete shift, replace valve.

TROUBLESHOOTING CHART — COOLING

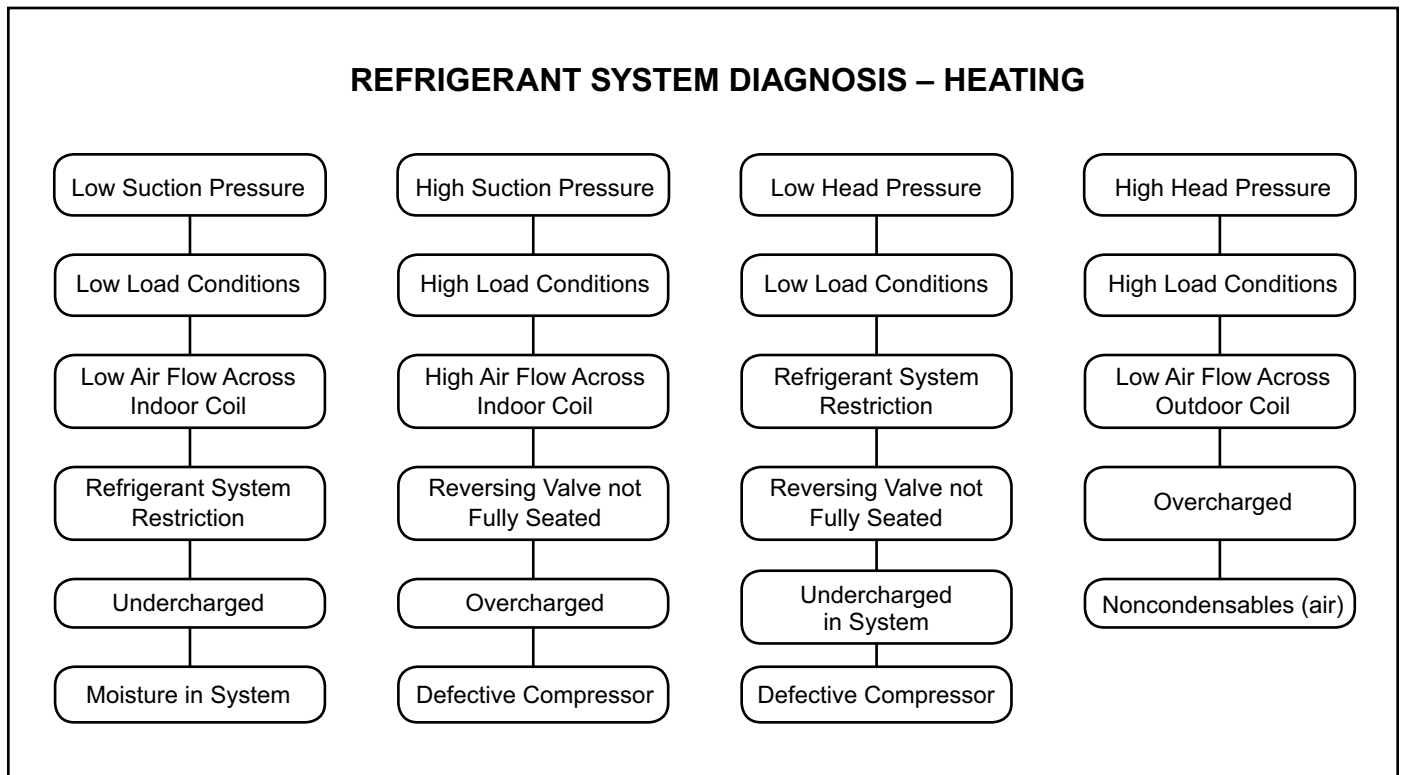

TROUBLESHOOTING CHART — HEATING

REFRIGERANT SYSTEM DIAGNOSIS – HEATING

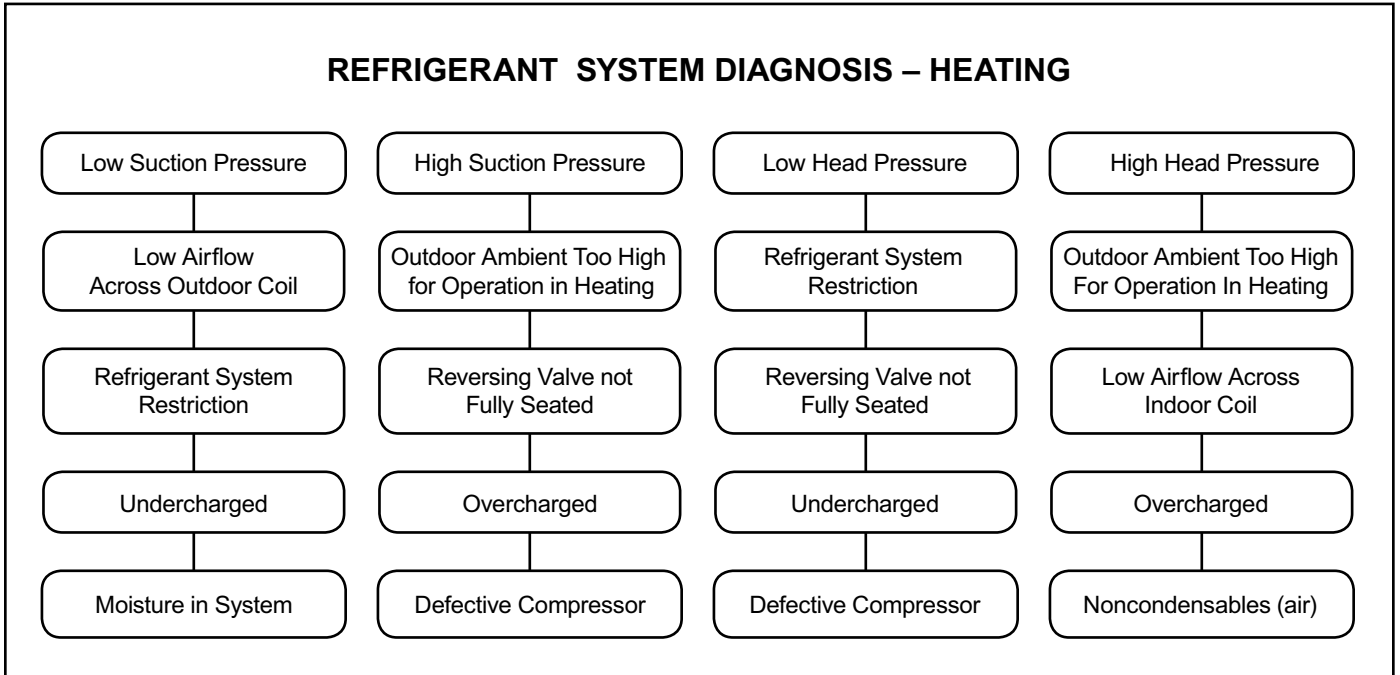

ELECTRICAL TROUBLESHOOTING CHART — HEAT PUMP

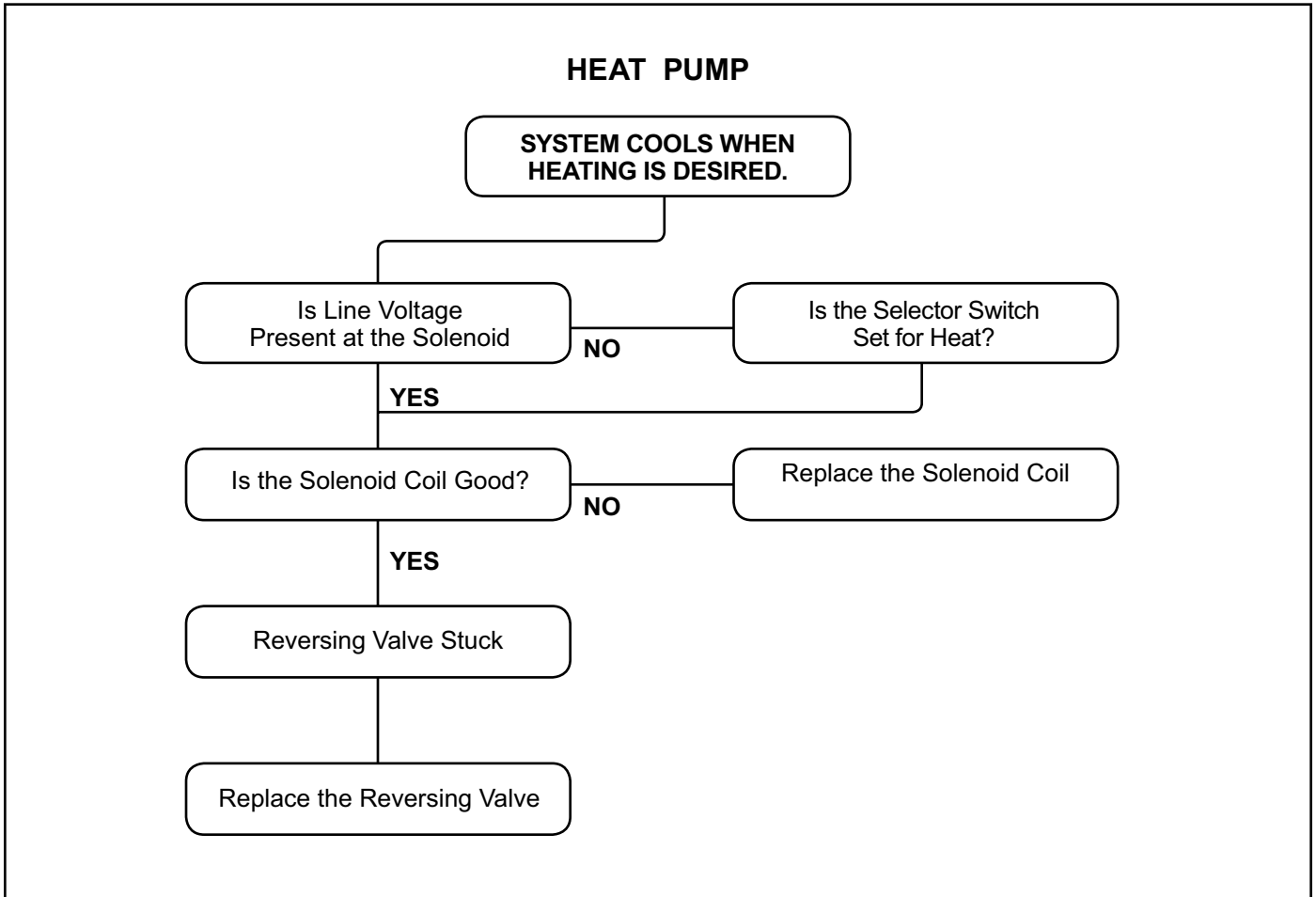

MODEL SC06H10D

WIRING DIAGRAM

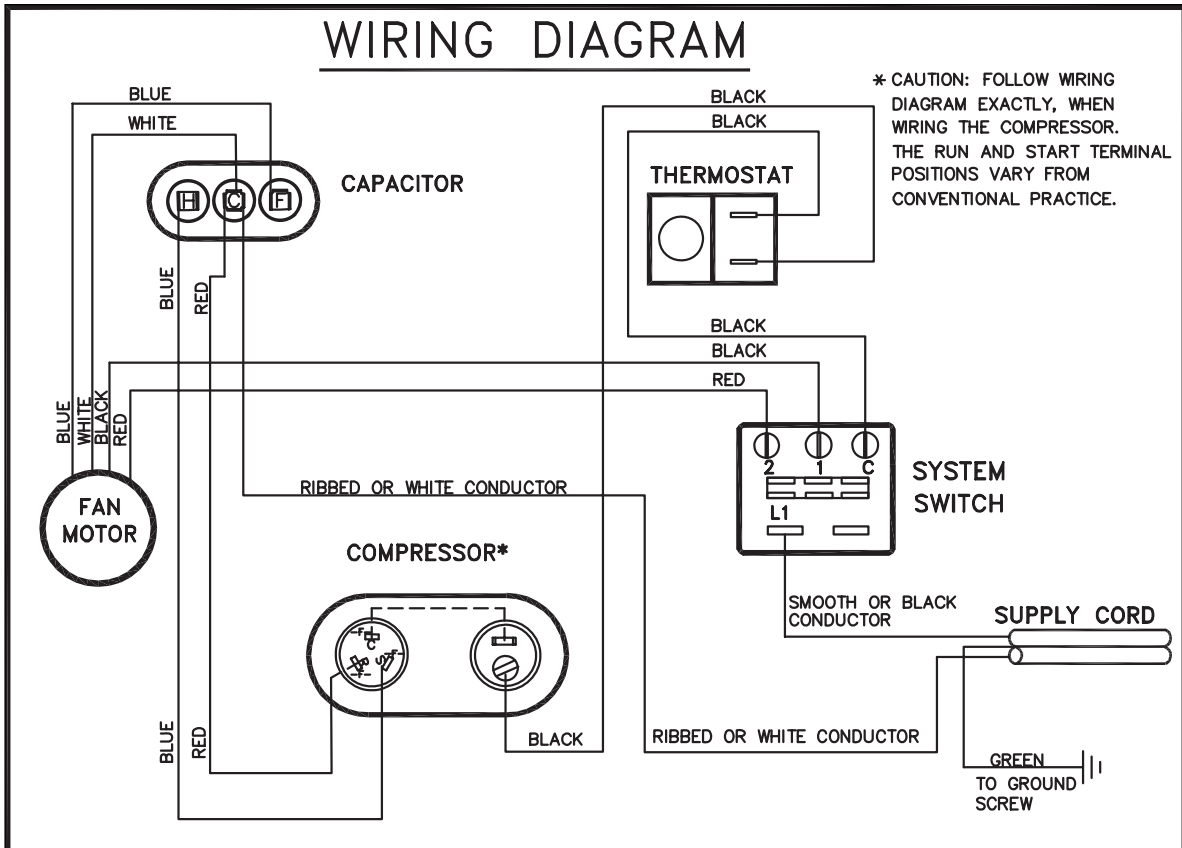

* CAUTION: FOLLOW WIRING DIAGRAM EXACTLY, WHEN WIRING THE COMPRESSOR. THE RUN AND START TERMINAL POSITIONS VARY FROM CONVENTIONAL PRACTICE.

SCHEMATIC

SYSTEM SWITCH SEQUENCE			
CLOSED CONTACTS			
○	○	○	○
OFF	HI-COOL	LO-COOL	HI-FAN
ALL OPEN	L1-1	L1-2	L1-1
	L1-C	L1-C	

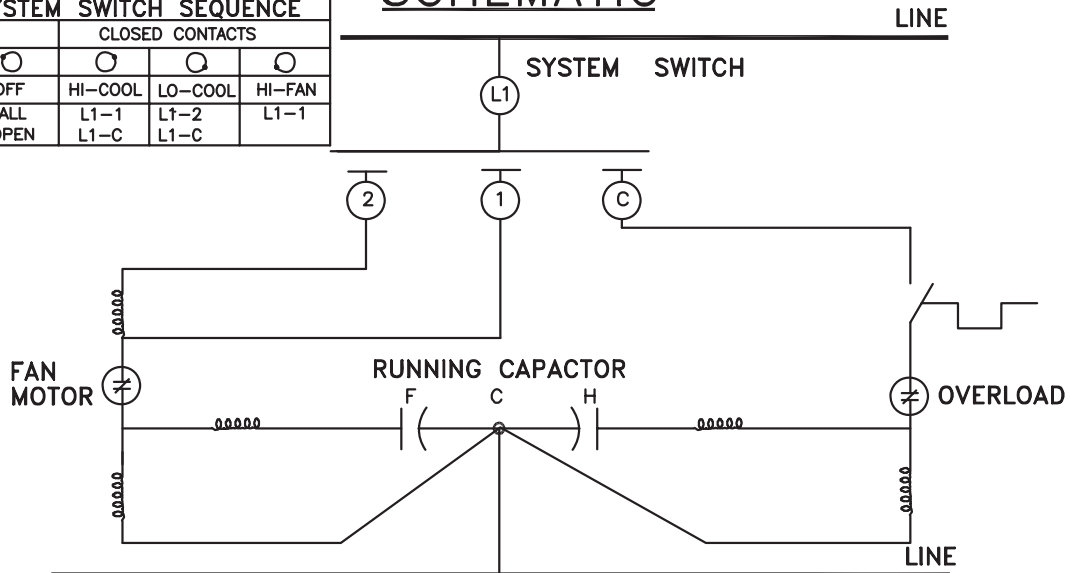

PART NO. 614-406-00
REV. 02

MODELS

XQ05L10-A,B; XQ06L10-A,B,C,D; XQ08L10-A,B; XQ10L10-A,B; XQ12L10-A,B

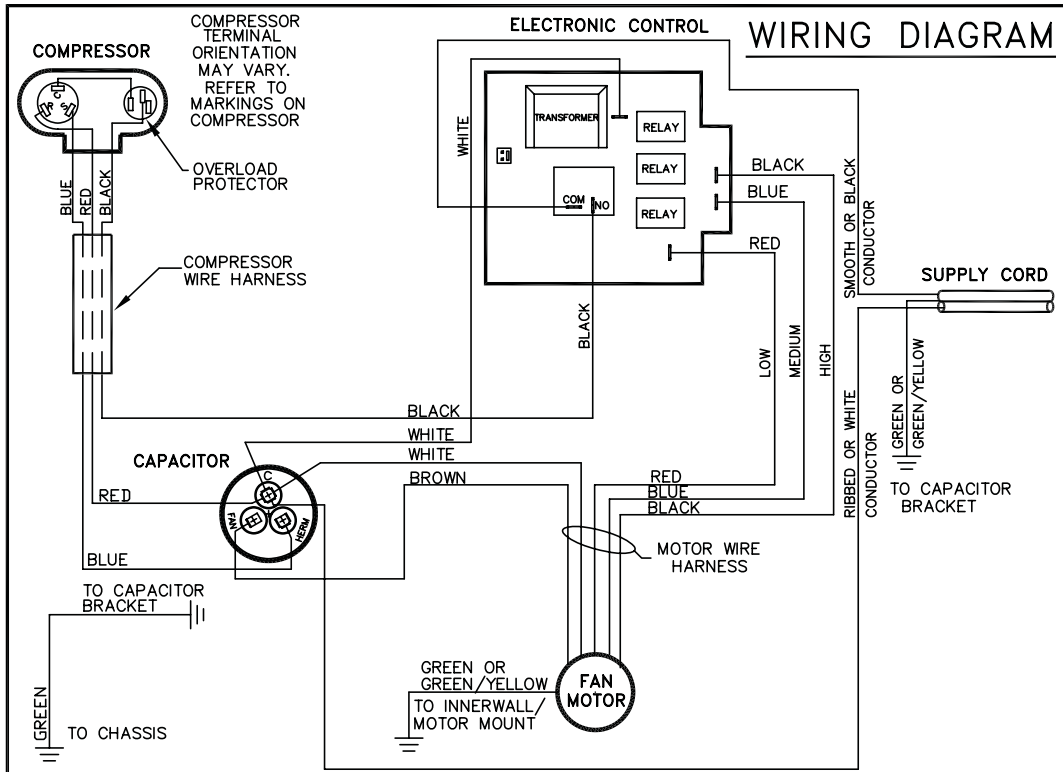

SCHEMATIC

NEUTRAL (115 V)

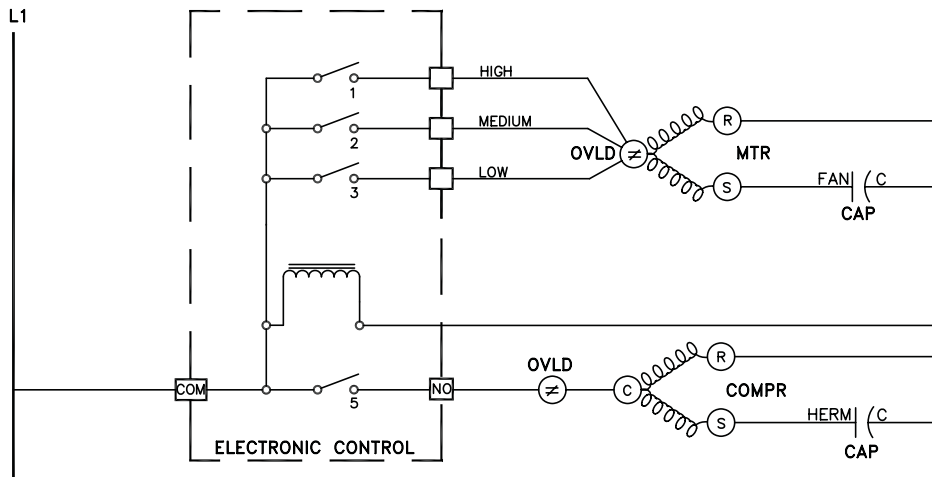

SWITCH LOGIC X = CLOSED
O = OPEN

SWITCH POSITION	1	2	3	4	5
OFF	0	0	0	0	0
HI COOL	X	0	0	0	X
MED COOL	0	X	0	0	X
LOW COOL	0	0	X	0	X

LEGEND

CAP - CAPACITOR
 COMPR - COMPRESSOR
 MTR - FAN MOTOR
 OVL - OVERLOAD PROTECTOR

● - COMBINATION TERMINAL
 —||— - GROUND LEAD

PART NO. 619-142-14
 REV. 05

MODELS

**KS10L10-A, RS10L10-A, KS12L10-A, KS12L30-A, KS15L10-A, RS15L10-A, RS16L30-A,
RM18L30-A, KM18L30-A, KM21L30-A, RM24L30-A, KM24L30-A**

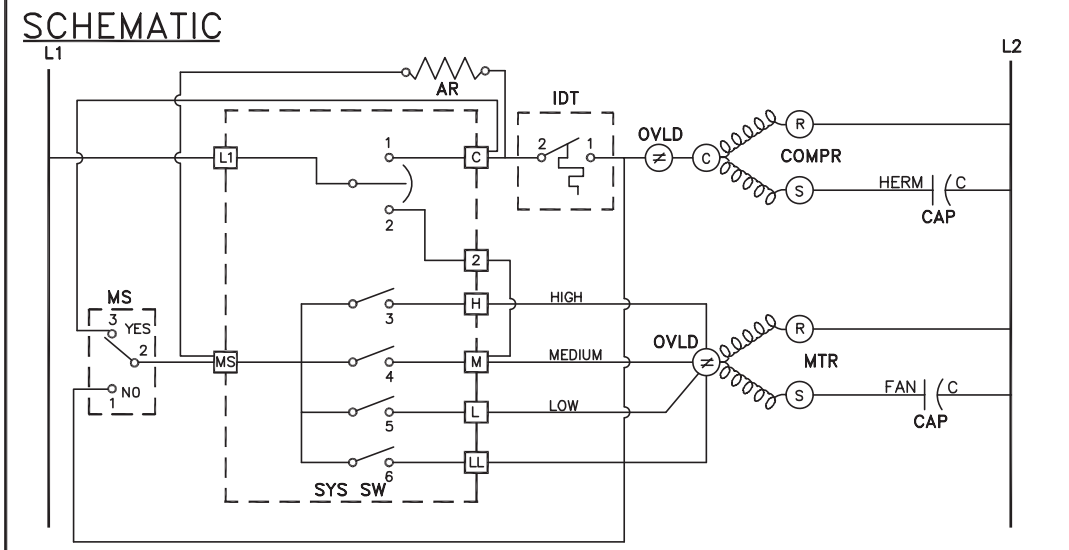
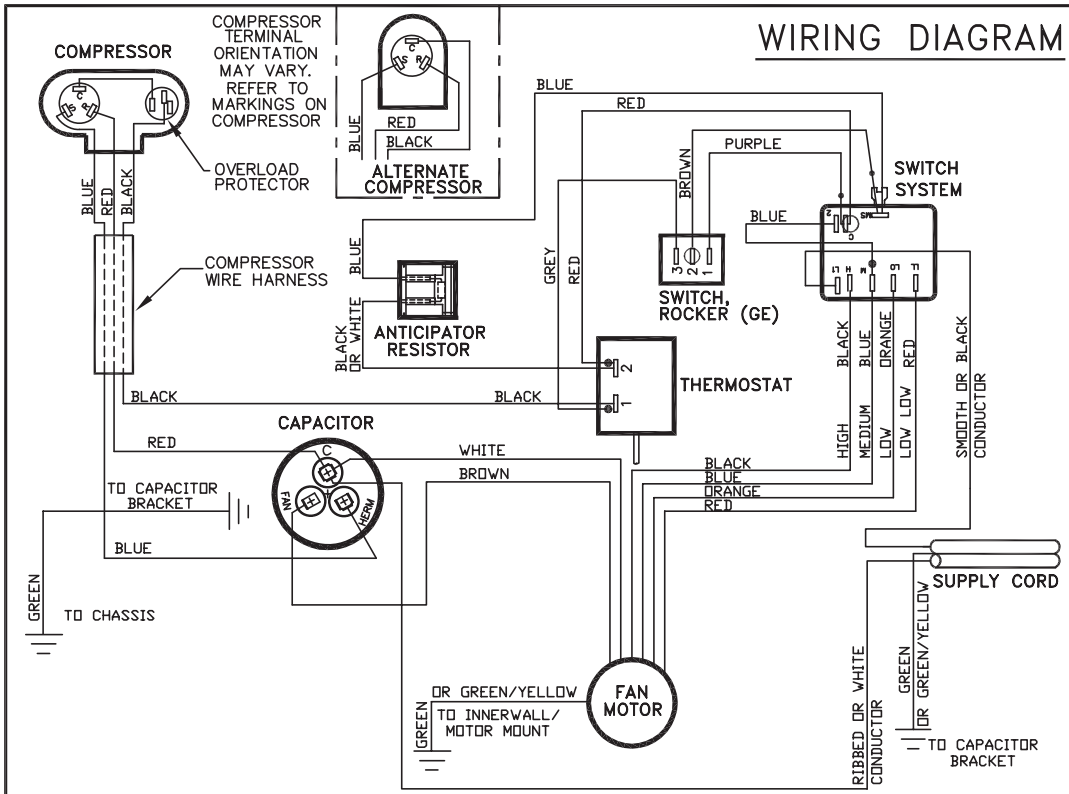

SWITCH LOGIC		X = CLOSED O = OPEN					
SWITCH POSITION	CIRCUIT	1	2	3	4	5	6
OFF		O	O	O	O	O	O
LOW COOL		X	O	O	O	X	O
MED COOL		X	O	X	O	O	O
HI COOL		X	O	X	O	O	O
FAN ONLY		O	X	O	O	O	O
LL COOL		X	O	O	O	O	X

LEGEND	
AR	- ANTICIPATOR RESISTOR
MS	- MONEY SAVER/ROCKER SWITCH
CAP	- CAPACITOR
COMPR	- COMPRESSOR
MTR	- FAN MOTOR
OVLD	- OVERLOAD PROTECTOR
SYS SW	- SYSTEM SWITCH
IDT	- INDOOR THERMOSTAT

	- GROUND LEAD
	- COMBINATION TERMINAL
	- PLASTIC INSULATOR

PART NO. 619-405-00	REV 01
------------------------	-----------

MODELS

**SS08L10-A/B, SS10L10-A/B, SS12L10-A/B; SS12L30-A/B, SS14L10-A/B,
SS16L30-A/B, SM18L30-A/B, SM21L30-A/B, SM24L30-A/B**

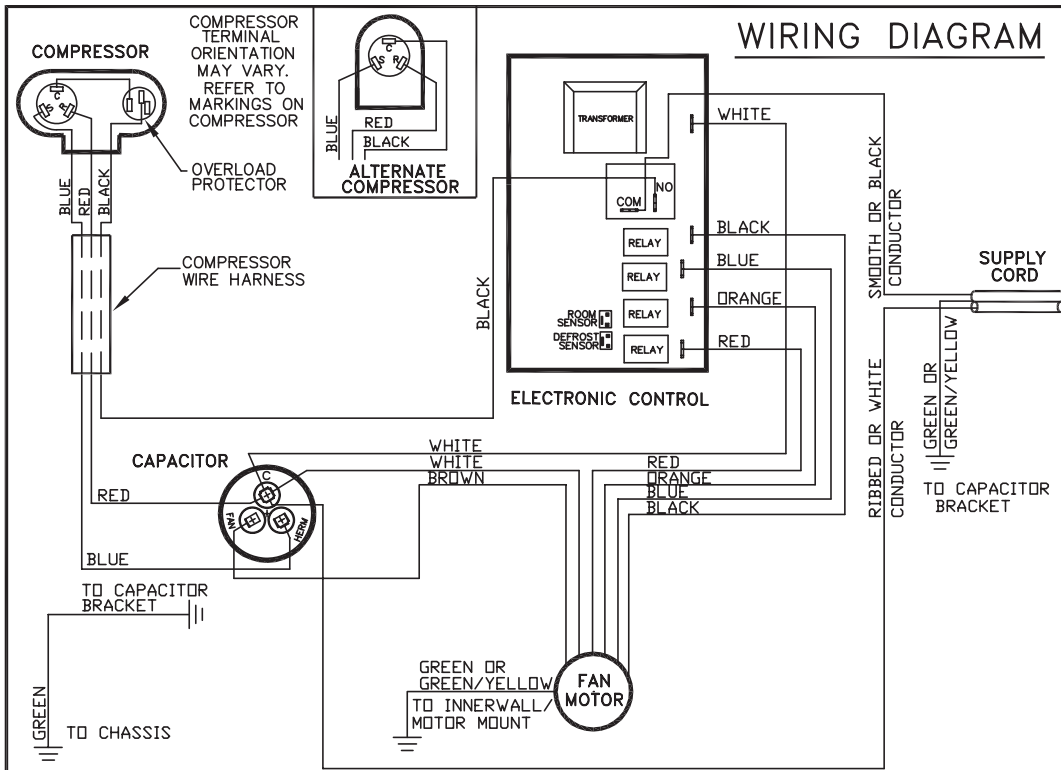

SCHEMATIC

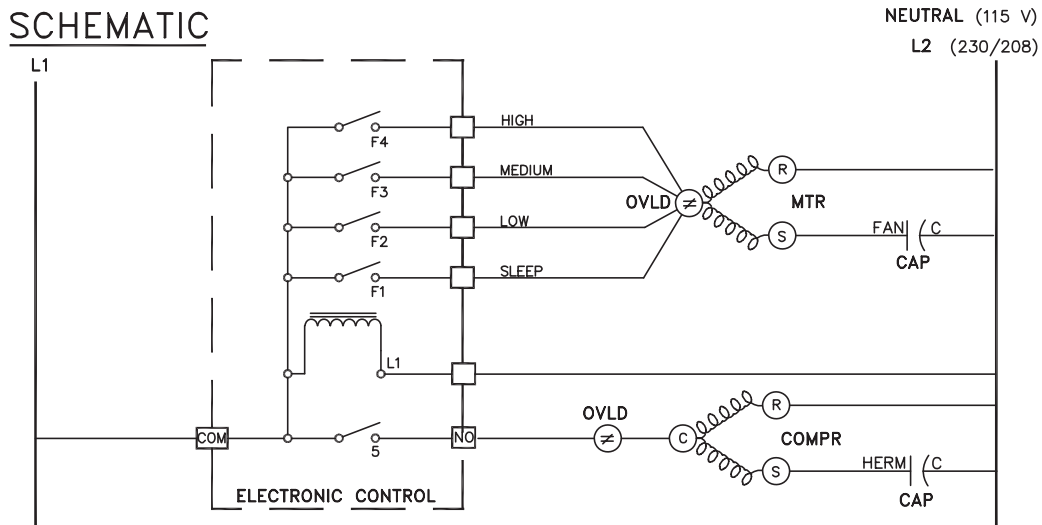

SWITCH LOGIC X = CLOSED
O = OPEN

SWITCH POSITION	1	2	3	4	5
OFF	O	O	O	O	O
HI COOL	X	O	O	O	X
MED COOL	O	X	O	O	X
LOW COOL	O	O	X	O	X
SLEEP	O	O	O	X	X

LEGEND

CAP - CAPACITOR
 COMPR - COMPRESSOR
 MTR - FAN MOTOR
 OVLD - OVERLOAD PROTECTOR

—●— - COMBINATION TERMINAL
 —||— - GROUND LEAD

PART NO. REV.
 619-405-06 02

MODEL SL36L30-A

WIRING DIAGRAM

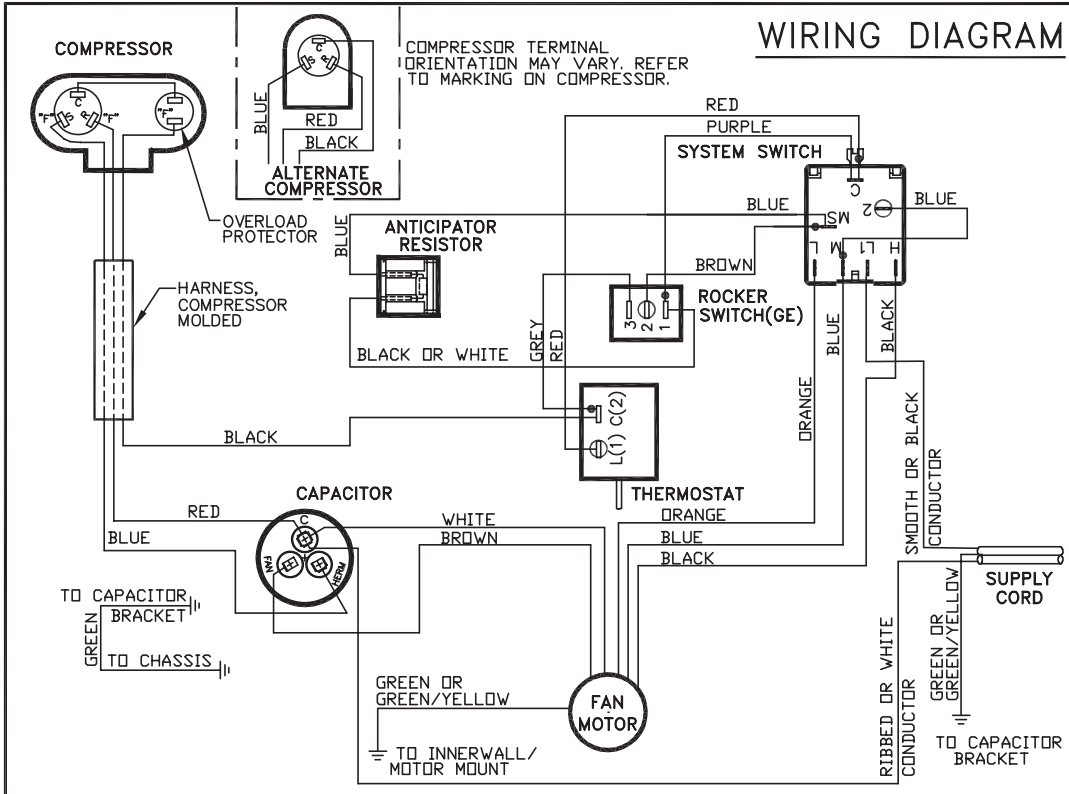

SCHEMATIC

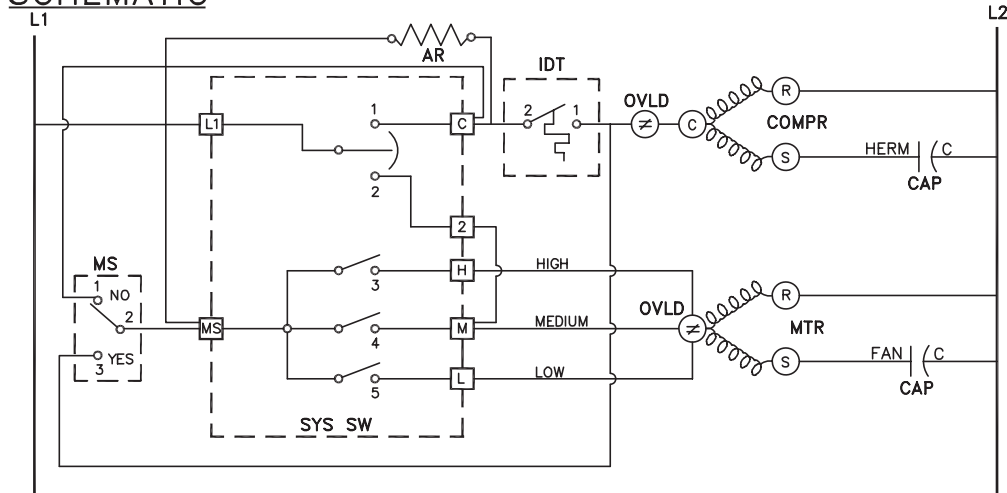

SWITCH LOGIC

X = CLOSED
O = OPEN

SWITCH POSITION	1	2	3	4	5
OFF	O	O	O	O	O
LOW COOL	X	O	O	O	X
MED COOL	X	O	X	O	O
HI COOL	X	O	X	O	O
FAN ONLY	O	X	O	O	O

LEGEND

AR - ANTICIPATOR RESISTOR
 MS - MONEY SAVER/ROCKER SWITCH
 CAP - CAPACITOR
 COMPR - COMPRESSOR
 MTR - FAN MOTOR
 OVLD - OVERLOAD PROTECTOR
 SYS SW - SYSTEM SWITCH
 IDT - INDOOR THERMOSTAT

—||— - GROUND LEAD
 ● - COMBINATION TERMINAL
 ○ - PLASTIC INSULATOR

PART NO. 619-405-11
 REV. 02

MODEL SL28L30-A

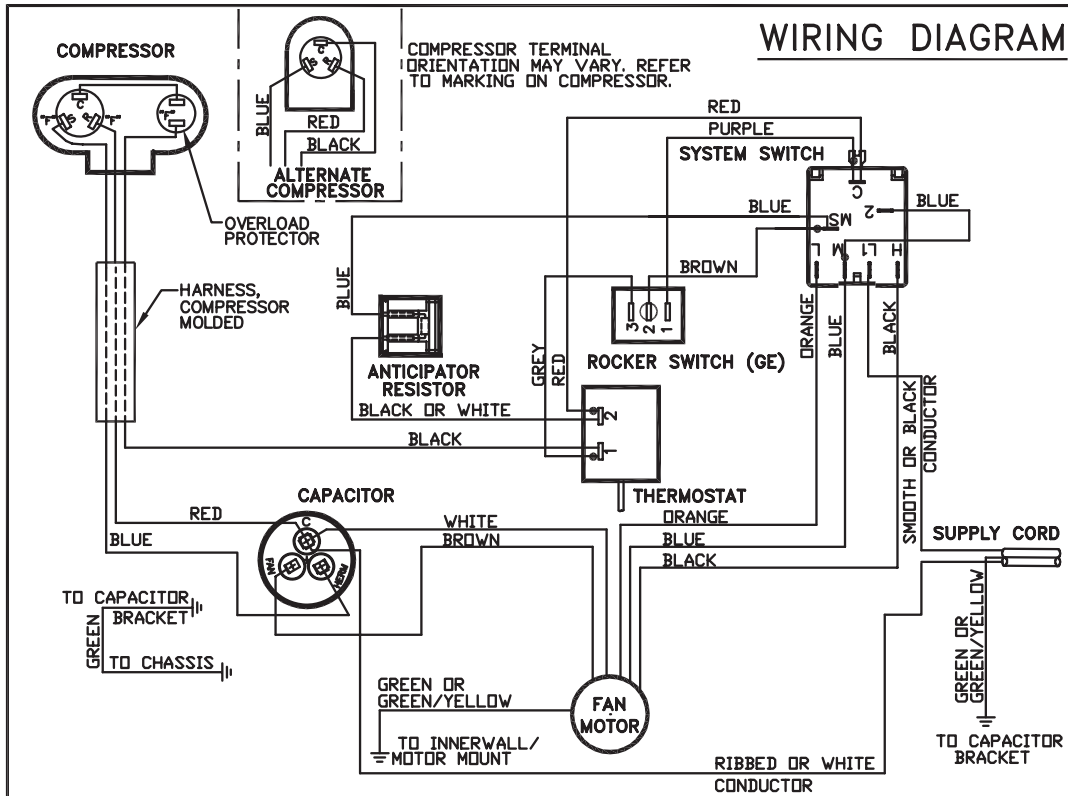

SCHEMATIC

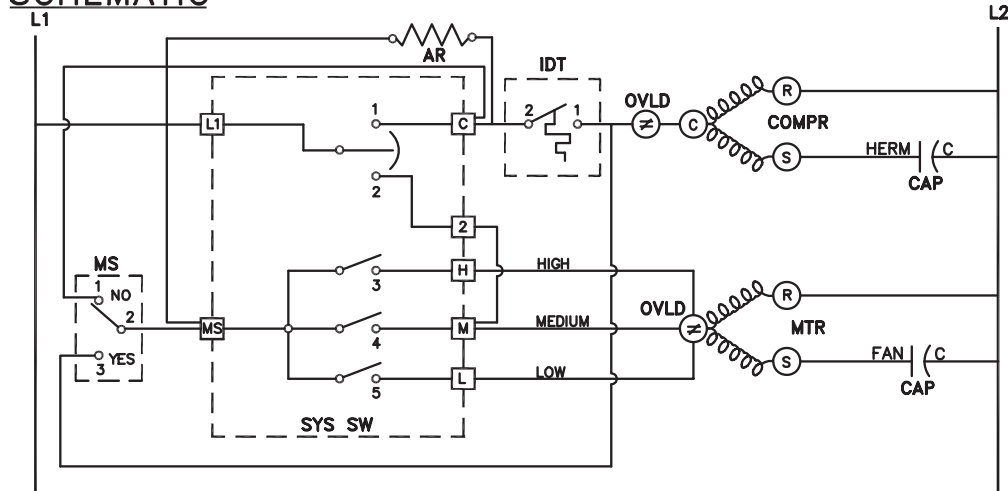

SWITCH LOGIC

X = CLOSED
O = OPEN

SWITCH POSITION	1	2	3	4	5
OFF	O	O	O	O	O
LOW COOL	X	O	O	X	O
MED COOL	X	O	X	O	O
HI COOL	X	O	X	O	O
FAN ONLY	O	X	O	O	O

LEGEND

AR - ANTICIPATOR RESISTOR
 MS - MONEY SAVER/ROCKER SWITCH
 CAP - CAPACITOR
 COMPR - COMPRESSOR
 MTR - FAN MOTOR
 OVLD - OVERLOAD PROTECTOR
 SYS SW - SYSTEM SWITCH
 IDT - INDOOR THERMOSTAT

—||— - GROUND LEAD
 ○—○— - COMBINATION TERMINAL
 ○ - PLASTIC INSULATOR

PART NO. 619-405-01
 REV. 01

MODELS SL36L30-B

WIRING DIAGRAM

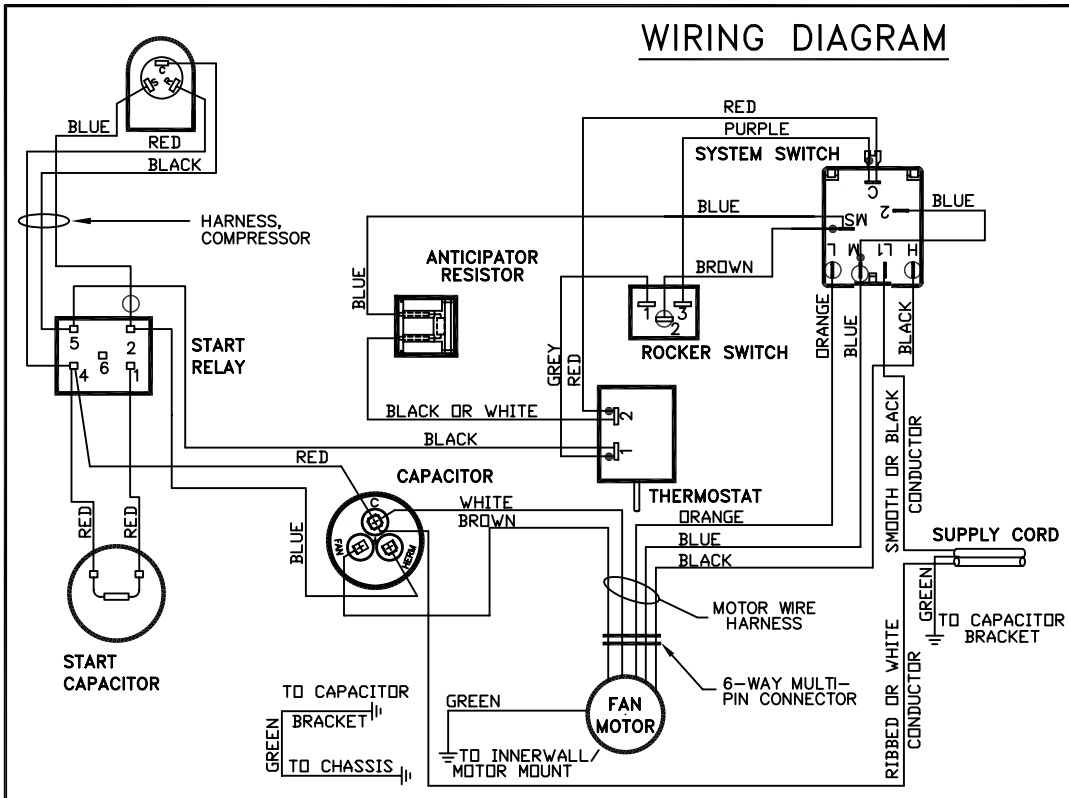

SCHEMATIC

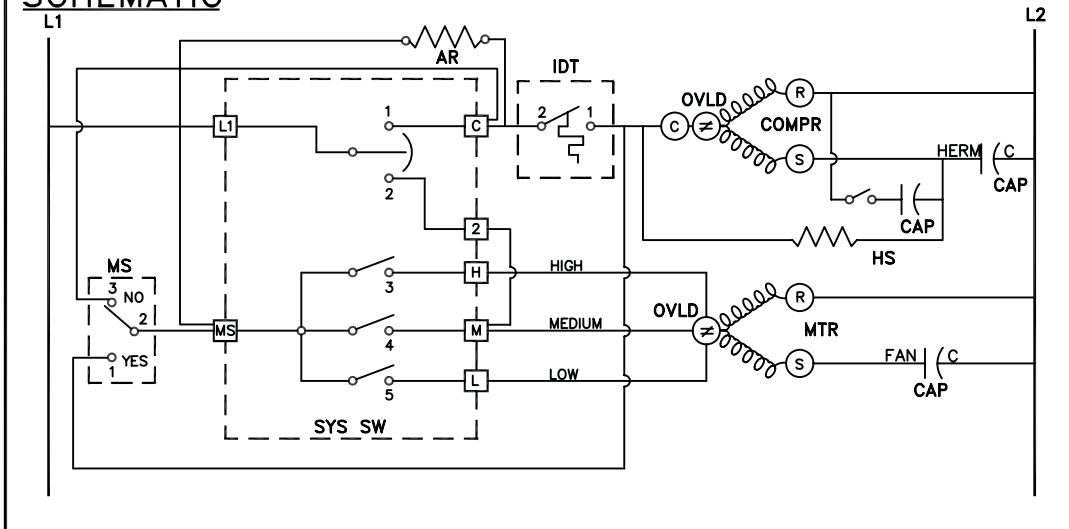

SWITCH LOGIC

X = CLOSED
0 = OPEN

SWITCH POSITION	1	2	3	4	5
OFF	0	0	0	0	0
LOW COOL	X	0	0	0	X
MED COOL	X	0	0	X	0
HI COOL	X	0	X	0	0
FAN ONLY	0	X	0	0	0

LEGEND

- AR - ANTICIPATOR RESISTOR
 - MS - MONEY SAVER/ROCKER SWITCH
 - CAP - CAPACITOR
 - COMP - COMPRESSOR
 - MTR - FAN MOTOR
 - OVLD - OVERLOAD PROTECTOR
 - SYS SW - SYSTEM SWITCH
 - IDT - INDOOR THERMOSTAT
 - HS - HARD START KIT
- GROUND LEAD
 - COMBINATION TERMINAL
 - PLASTIC INSULATOR

PART NO.	REV.
619-142-13	02

MODEL EQ08L11-A

WIRING DIAGRAM

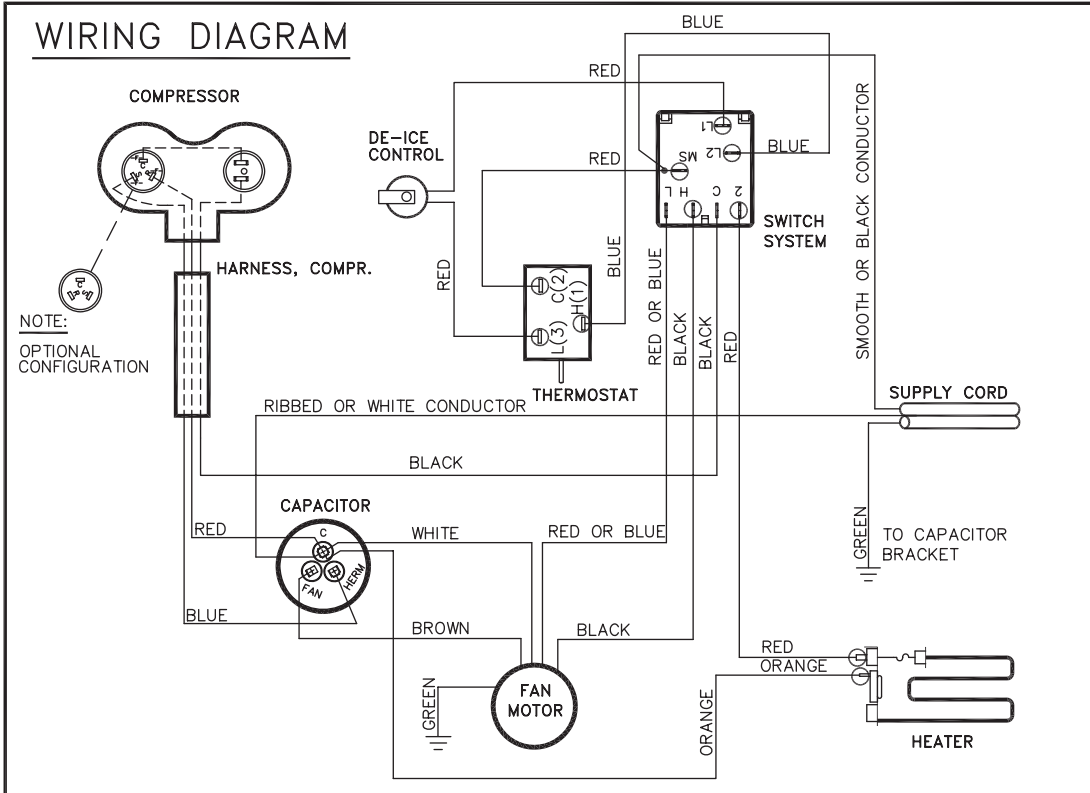

SCHEMATIC

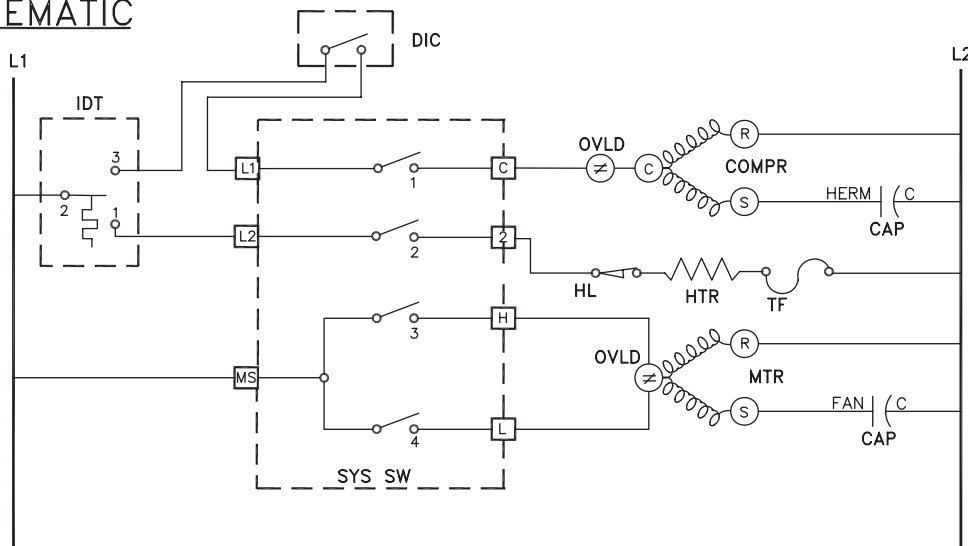

SWITCH LOGIC

X = CLOSED
0 = OPEN

SWITCH POSITION	1	2	3	4
OFF	0	0	0	0
FAN	0	0	X	0
HI COOL	X	0	X	0
LOW COOL	X	0	0	X
LOW HEAT	0	X	0	X
HI HEAT	0	X	X	0

LEGEND

HL	- HEATER LIMIT	TF	- THERMAL FUSE
CAP	- CAPACITOR	○	- INSULATED TERMINAL
COMPR	- COMPRESSOR	— —	- GROUND LEAD
MTR	- FAN MOTOR	— —	- COMBINATION TERMINAL
OVLD	- OVERLOAD PROTECTOR	-F-	- FLAG TERMINAL
SYS SW	- SYSTEM SWITCH	DIC	- DE ICE CONTROL
IDT	- INDOOR THERMOSTAT		
HTR	- HEATER		

PART NO.
617-581-17

REV.
02

MODELS ES12L33-A, ES16L33-A, EM18L34-A, EM24L35-A

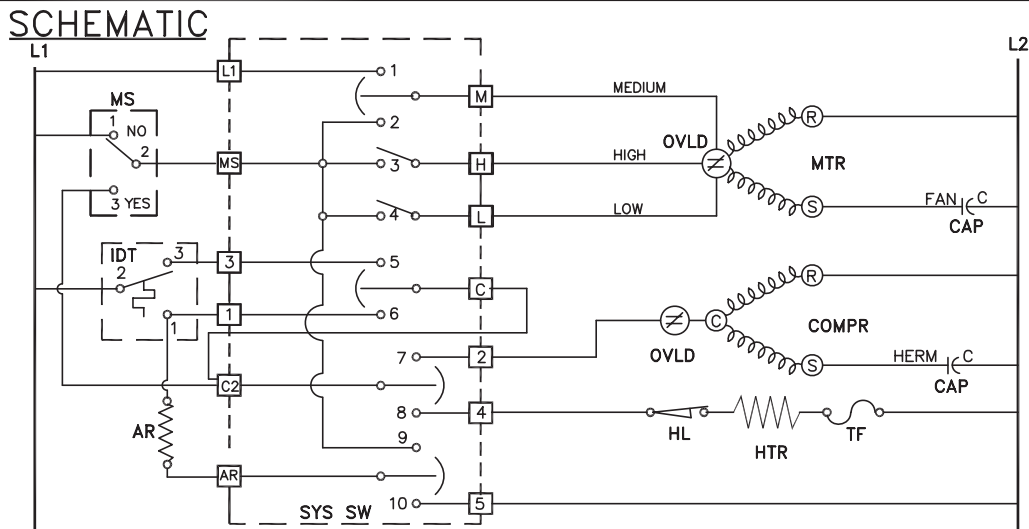
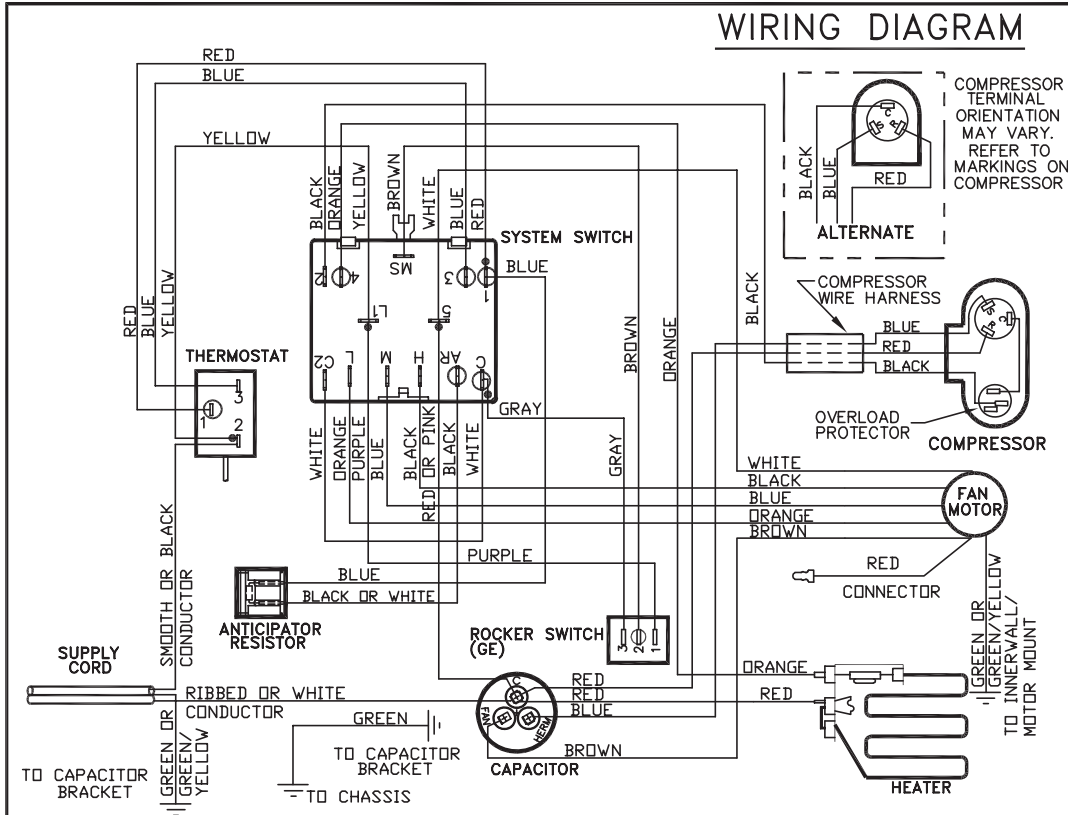

SWITCH POSITION	CIRCUIT									
	1	2	3	4	5	6	7	8	9	10
OFF	0	0	0	0	0	0	0	0	0	0
LOW COOL	0	0	0	X	X	0	X	0	X	0
MEDIUM COOL	0	X	0	0	X	0	X	0	X	0
HIGH COOL	0	0	X	0	X	0	X	0	X	0
HIGH HEAT	0	0	X	0	X	0	X	0	X	0
MEDIUM HEAT	0	X	0	0	X	0	X	0	X	0
LOW HEAT	0	0	0	X	0	X	0	X	0	X
FAN ONLY	X	0	0	0	0	0	0	0	0	0

LEGEND	
AR	- ANTICIPATOR RESISTOR
MS	- MONEY SAVER/ROCKER SWITCH
CAP	- CAPACITOR
COMPR	- COMPRESSOR
MTR	- FAN MOTOR
OVL	- OVERLOAD PROTECTOR
SYS SW	- SYSTEM SWITCH
IDT	- INDOOR THERMOSTAT
HTR	- HEATER
HL	- HEATER LIMIT
TF	- THERMAL FUSE
	- GROUND LEAD
	- COMBINATION TERMINAL
	- PLASTIC INSULATOR

PART NO. 619-405-16 REV. 02

MODEL EL36L35-A

WIRING DIAGRAM

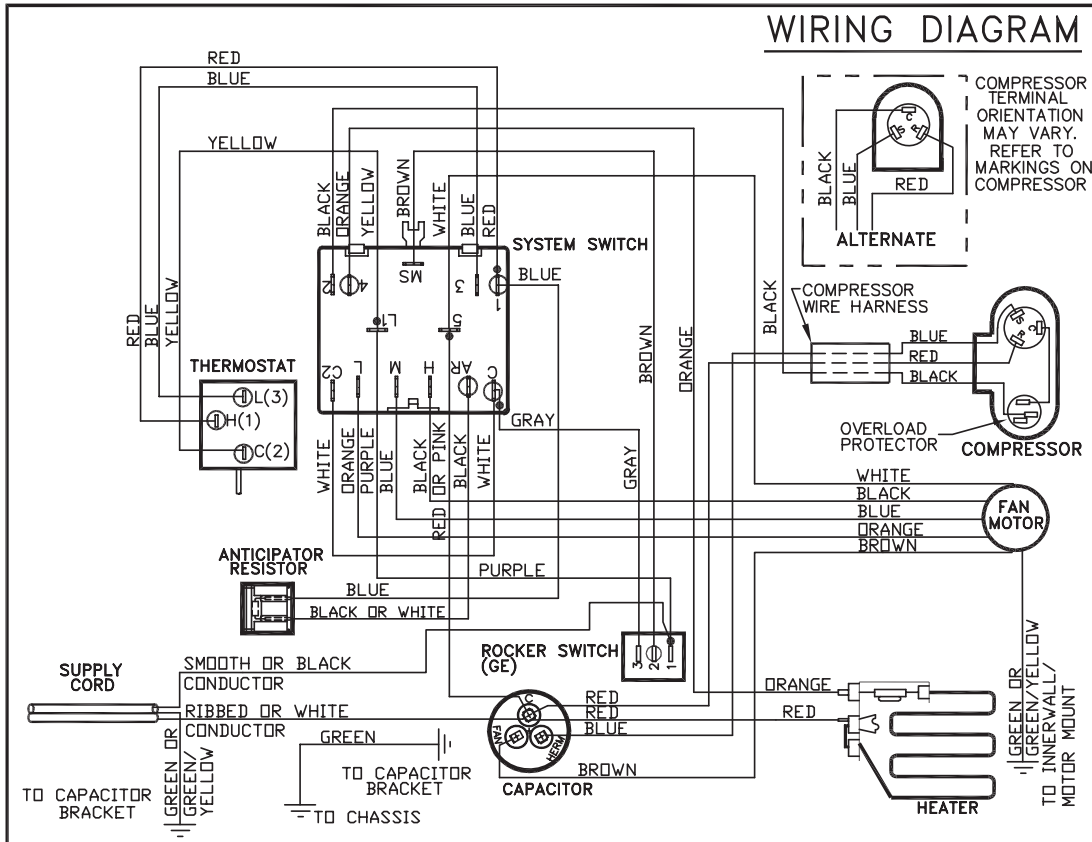

SCHEMATIC

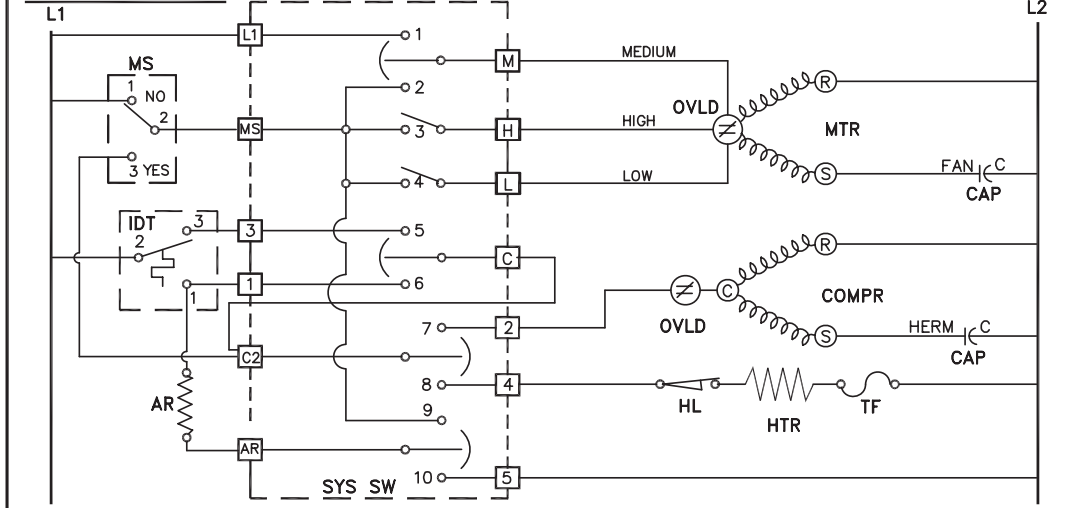

SWITCH POSITION	CIRCUIT									
	1	2	3	4	5	6	7	8	9	10
OFF	0	0	0	0	0	0	0	0	0	0
LOW COOL	0	0	0	X	X	0	X	0	X	0
MEDIUM COOL	0	X	0	0	X	0	X	0	X	0
HIGH COOL	0	0	X	0	X	0	X	0	X	0
HIGH HEAT	0	0	X	0	0	X	0	X	0	X
MEDIUM HEAT	0	X	0	0	0	X	0	X	0	X
LOW HEAT	0	0	0	X	0	X	0	X	0	X
FAN ONLY	X	0	0	0	0	0	0	0	0	0

- SWITCH LOGIC**
X = CLOSED
0 = OPEN
- LEGEND**
- AR - ANTICIPATOR RESISTOR
 - MS - MONEY SAVER/ROCKER SWITCH
 - CAP - CAPACITOR
 - COMPR - COMPRESSOR
 - MTR - FAN MOTOR
 - OVL - OVERLOAD PROTECTOR
 - SY SW - SYSTEM SWITCH
 - IDT - INDOOR THERMOSTAT
 - HTR - HEATER
 - HL - HEATER LIMIT
 - TF - THERMAL FUSE
 - |—|— | GROUND LEAD
 - - COMBINATION TERMINAL
 - - PLASTIC INSULATOR

PART NO. 619-405-12
REV. 04

MODELS YL24L35-A

WIRING DIAGRAM

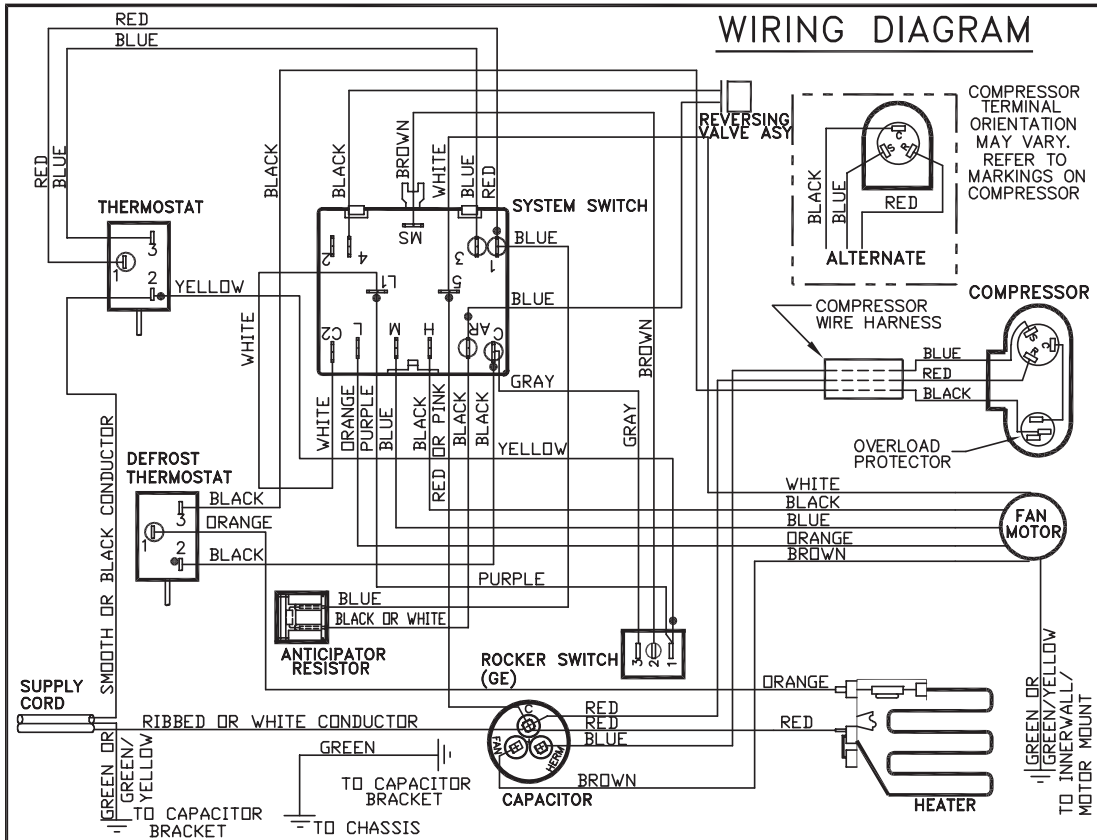

SCHEMATIC

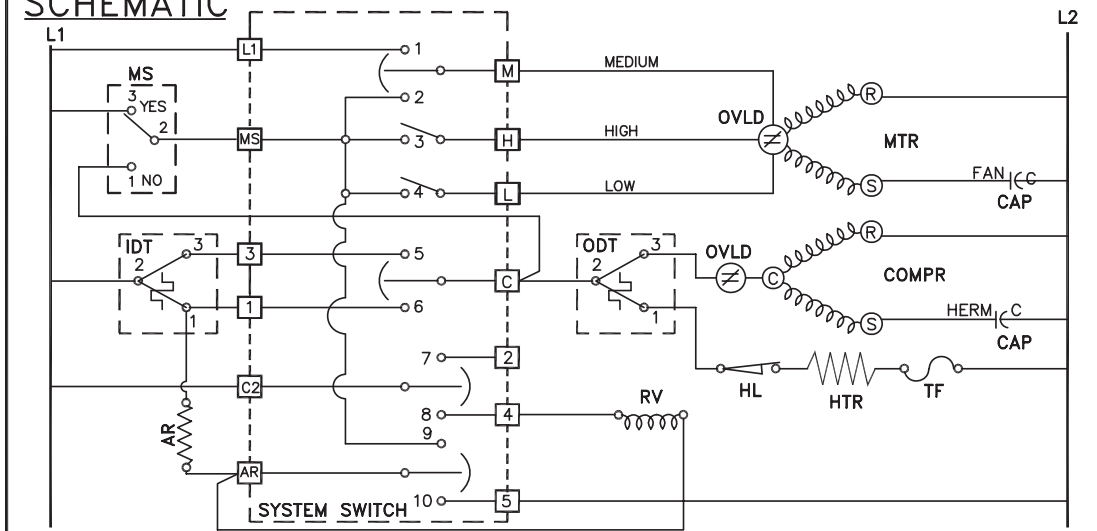

SWITCH LOGIC

SWITCH POSITION	CIRCUIT									
	1	2	3	4	5	6	7	8	9	10
OFF	0	0	0	0	0	0	0	0	0	0
LOW COOL	0	0	0	X	X	0	X	X	0	0
MEDIUM COOL	0	X	0	0	X	0	X	X	0	0
HIGH COOL	0	0	X	0	X	0	X	X	0	0
HIGH HEAT	0	0	0	X	0	0	X	X	0	0
MEDIUM HEAT	0	X	0	0	X	0	X	X	0	0
LOW HEAT	0	0	0	X	0	0	X	X	0	0
FAN ONLY	X	0	0	0	0	0	0	0	0	0

LEGEND

- AR - ANTICIPATOR RESISTOR
- MS - MONEY SAVER
- CAP - CAPACITOR
- COMPR - COMPRESSOR
- MTR - FAN MOTOR
- OVL - OVERLOAD
- RV - REVERSING VALVE
- IDT - INDOOR THERMOSTAT
- ODT - OUTDOOR THERMOSTAT
- HTR - HEATER
- HL - HEATER LIMIT
- TF - THERMAL FUSE
- |— | GROUND LEAD
- - COMBINATION TERMINAL
- - PLASTIC INSULATOR

PART NO. 619-405-04
REV. 03

Friedrich

Friedrich Air Conditioning Co.

Post Office Box 1540 • San Antonio, Texas 78295-1540

4200 N. Pan Am Expressway • San Antonio, Texas 78218-5212

(210) 357-4400 • FAX (210) 357-4480

www.friedrich.com

Printed in the U.S.A.

RAC-Svc-06 (3-06)