



4-Port Powered USB 2.0 Hub Operations Guide

with External Power Supply

Part #010807

CyberData Corporation
2555 Garden Road
Monterey, CA 93940
(831) 373-2601

**4-Port PoweredUSB 2.0 Hub Operations Guide 930103E
Part # 010807**

COPYRIGHT NOTICE:

© 2009, CyberData Corporation, ALL RIGHTS RESERVED.

This manual and related materials are the copyrighted property of CyberData Corporation. No part of this manual or related materials may be reproduced or transmitted, in any form or by any means (except for internal use by licensed customers), without prior express written permission of CyberData Corporation. This manual, and the products, software, firmware, and/or hardware described in this manual are the property of CyberData Corporation, provided under the terms of an agreement between CyberData Corporation and recipient of this manual, and their use is subject to that agreement and its terms.

DISCLAIMER: Except as expressly and specifically stated in a written agreement executed by CyberData Corporation, CyberData Corporation makes no representation or warranty, express or implied, including any warranty or merchantability or fitness for any purpose, with respect to this manual or the products, software, firmware, and/or hardware described herein, and CyberData Corporation assumes no liability for damages or claims resulting from any use of this manual or such products, software, firmware, and/or hardware. CyberData Corporation reserves the right to make changes, without notice, to this manual and to any such product, software, firmware, and/or hardware.

OPEN SOURCE STATEMENT: Certain software components included in CyberData products are subject to the GNU General Public License (GPL) and Lesser GNU General Public License (LGPL) "open source" or "free software" licenses. Some of this Open Source Software may be owned by third parties. Open Source Software is not subject to the terms and conditions of the CyberData COPYRIGHT NOTICE or software licenses. Your right to copy, modify, and distribute any Open Source Software is determined by the terms of the GPL, LGPL, or third party, according to who licenses that software.

Software or firmware developed by CyberData that is unrelated to Open Source Software is copyrighted by CyberData, subject to the terms of CyberData licenses, and may not be copied, modified, reverse-engineered, or otherwise altered without explicit written permission from CyberData Corporation.

TRADEMARK NOTICE: CyberData Corporation and the CyberData Corporation logos are trademarks of CyberData Corporation. Other product names, trademarks, and service marks may be the trademarks or registered trademarks of their respective owners.



Phone: (831) 373-2601
Technical Support Ext. 333
support@CyberData.net
Fax: (831) 373-4193
Company and product information at www.cyberdata.net

Contents

Chapter 1 Product Overview	1
1.1 Product features	1
1.2 License note	2
1.3 Documentation note	2
1.4 Dimensions	3
Chapter 2 Installing and Using the 4-Port PoweredUSB Hub	4
2.1 Product Components List	5
2.2 Product Compatibility	6
2.3 Installation	6
2.4 Connections	7
2.4.1 Power Supply	7
2.4.2 Host Connector	8
2.4.3 PoweredUSB Connections	8
2.4.4 Connector Color Keys	9
2.4.5 Peripherals Connections to the SiP VoIP and PoE Speaker	10
2.4.6 Peripheral Cable Connection Options	11
2.5 Operation	14
2.5.1 POS Peripheral Caveat	14
2.6 Port Electrical Specifications	15
2.6.1 Standard USB lower A supply	15
2.6.2 PoweredUSB supply	15
Appendix A Regulatory and Safety Information	16
Appendix B Setting up the Hub on Windows XP	17
Appendix C Troubleshooting/Technical Support	18
C.1 Frequently Asked Questions (FAQ)	18
C.2 Documentation	18
C.3 Contact Information	18
C.4 Warranty	19
Index	20

1 Product Overview

The SiP VoIP and PoE Speaker provides a simple, affordable way to add up to four PoweredUSB ports to your PC. These additional ports are controlled by the PC's Standby and Wake commands. This add-on Hub makes it easy to connect the PC to devices that require more than the 500mA of +5 volts supplied with the standard USB interface.

Figure 1-1. CyberData 4-Port PoweredUSB 2.0 Hub



1.1 Product features

- 4 PoweredUSB ports
- One +24 volt up to 2.3A
- Three +12 volt up to 1.5A each
- Short circuit and over current protected
- Multiple power supply options
- Plug-n-Play installation
- Peripheral power controlled by PC stand-by and wake commands
- LED indicators for port power output and USB 2.0 status
- Two-year warranty

1.2 License note

The PoweredUSB controller board contains certain technology that is covered by an IBM® patent. CyberData Corporation is licensed with IBM to manufacture, and to sell or lease products that incorporate this technology. This license also permits other entities to resell or release these Cyberdata products after they have been purchased from CyberData.

1.3 Documentation note

The documentation for this product is released in an English language version only.

1.4 Dimensions

Figure 1-2. Dimensions

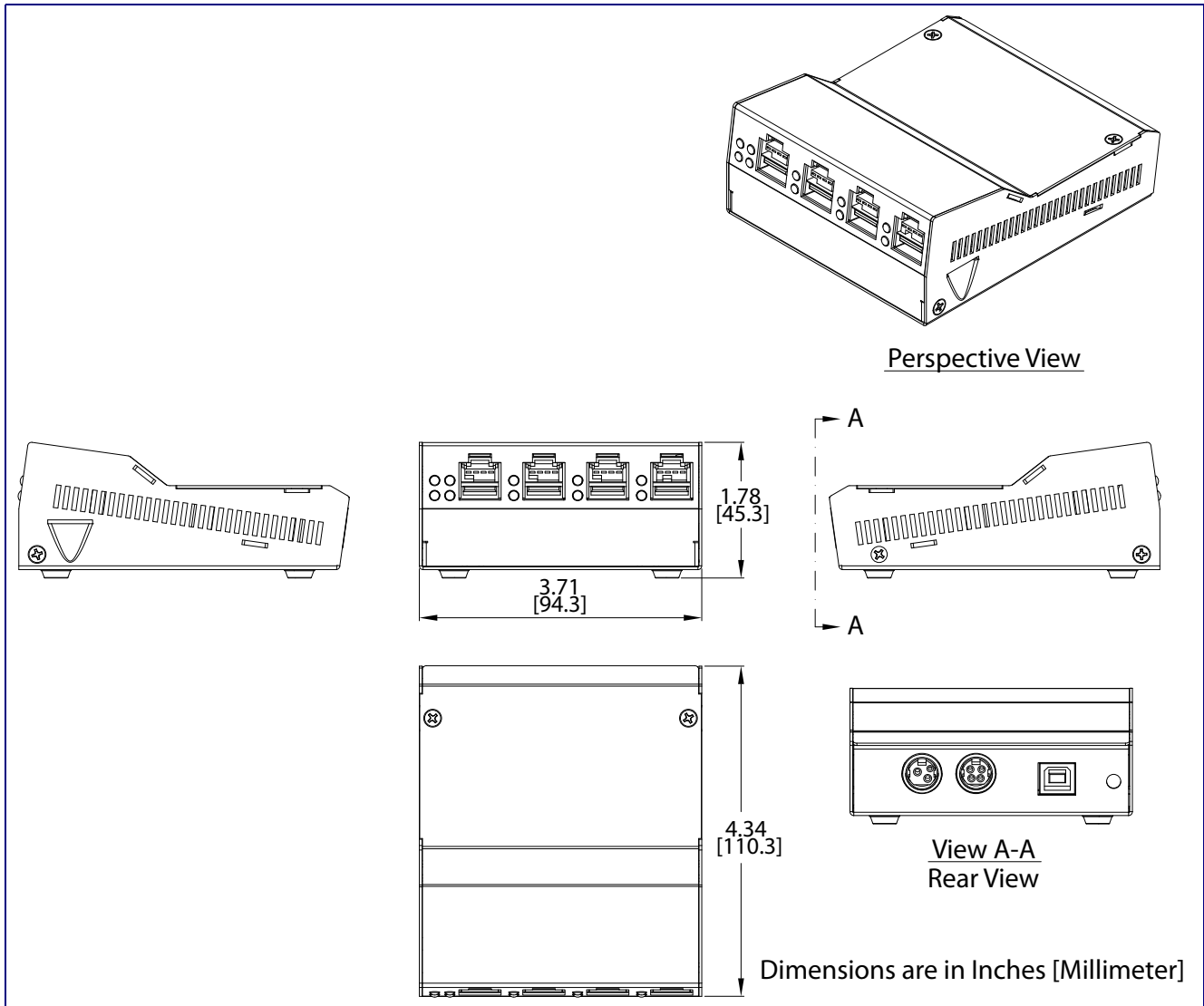

2 Installing and Using the 4-Port PoweredUSB Hub

This chapter provides the instructions, illustrations, and background information you need to install, and begin working with the SiP VoIP and PoE Speaker.

- [Section 2.1, "Product Components List"](#)
- [Section 2.2, "Product Compatibility"](#)
- [Section 2.3, "Installation"](#)
- [Section 2.4, "Connections"](#)
- [Section 2.5, "Operation"](#)
- [Section 2.6, "Port Electrical Specifications"](#)

Figure 2-3. CyberData 4-Port PoweredUSB 2.0 Hub

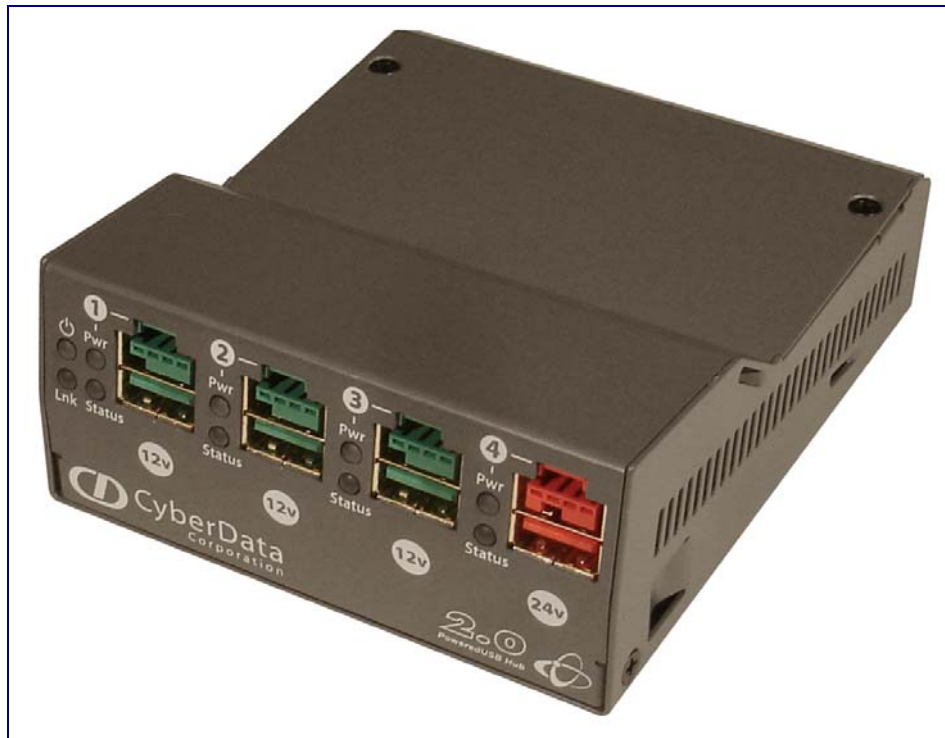

2.1 Product Components List

The 4-Port PoweredUSB 2.0 Hub package includes these parts:

- (1) SiP VoIP and PoE Speaker
- Power Supply, 24VDC, Desk-top, 4-Pin Hosiden style plug
- (1) Accessory Kit
 - (1) Short USB 2.0 Hi-Speed host cable
 - (1) Host USB cable strain relief clamp
 - (1) *4-Port PoweredUSB 2.0 Hub Operations Guide*

Figure 2-4. CyberData 4-Port PoweredUSB 2.0 Hub—Front View

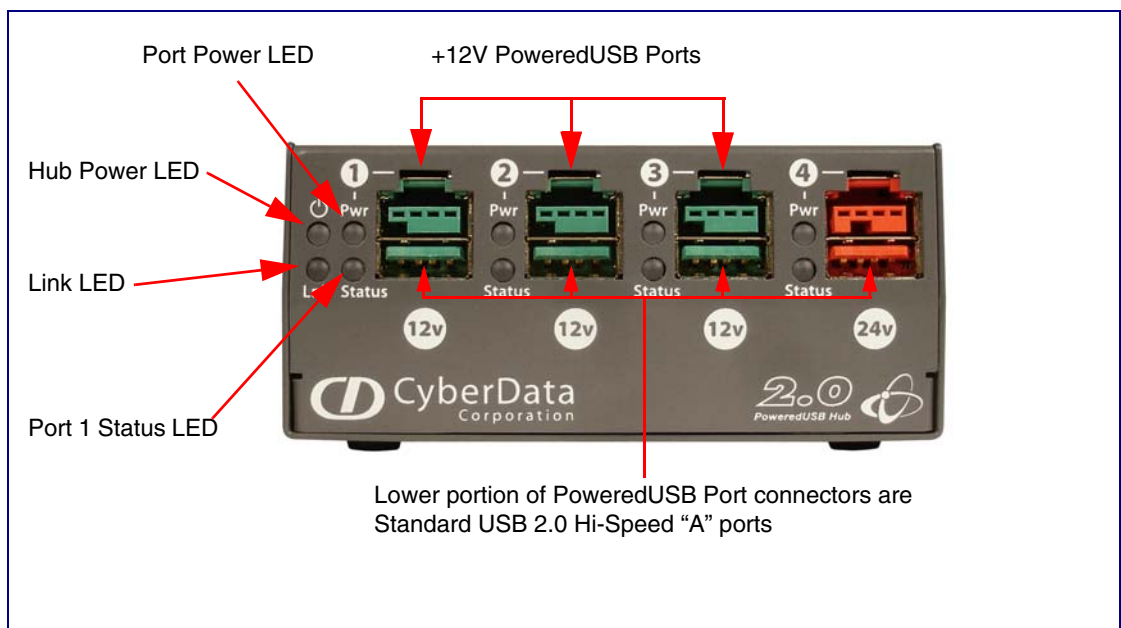

Figure 2-5. CyberData 4-Port PoweredUSB 2.0 Hub—Back View



2.2 Product Compatibility

The SiP VoIP and PoE Speaker is compatible with the following operating systems and USB standards.

Table 2-1. Operating Systems

Operating systems	USB
Windows 2000 and XP	2.0 Standard
LINUX	PoweredUSB 0.8g
Mac OS-X	

2.3 Installation

The SiP VoIP and PoE Speaker is a tabletop unit with mounting feet that sit on a flat surface.

2.4 Connections

The following topics provide illustrations and information on connecting the SiP VoIP and PoE Speaker to power supplies, the host, and peripheral devices.

- [Section 2.4.1, "Power Supply"](#)
- [Section 2.4.2, "Host Connector"](#)
- [Section 2.4.3, "PoweredUSB Connections"](#)
- [Section 2.4.4, "Connector Color Keys"](#)
- [Section 2.4.5, "Peripherals Connections to the SiP VoIP and PoE Speaker"](#)
- [Section 2.4.6, "Peripheral Cable Connection Options"](#)

2.4.1 Power Supply

The PoweredUSB specification requires supplying +24V at 2.3A and +12V at 1.5A to each voltage designated port. These requirements are met only if the power supply has sufficient wattage for this amount of power.

The Epson PS180 brick and Dell printer power supply are examples of lower-cost alternate power supplies that can be used with this Hub and peripherals requiring less power. Two power plug receptacles are provided on the back of the SiP VoIP and PoE Speaker to facilitate the use of alternate power supplies.

The three-pin connector is normally used for the Dell and Epson Bricks. The four-pin connector is used for a high-current power supply. See [Figure 2-10](#) for an illustration of cable routing from the SiP VoIP and PoE Speaker.

CAUTION The P1 and P2 DC input jacks on the back of this Hub are for *input only*. Do *not* plug power supplies into both input jacks simultaneously as equipment damage that might void the product warranty could occur.

Figure 2-6. Power Connectors—Back View

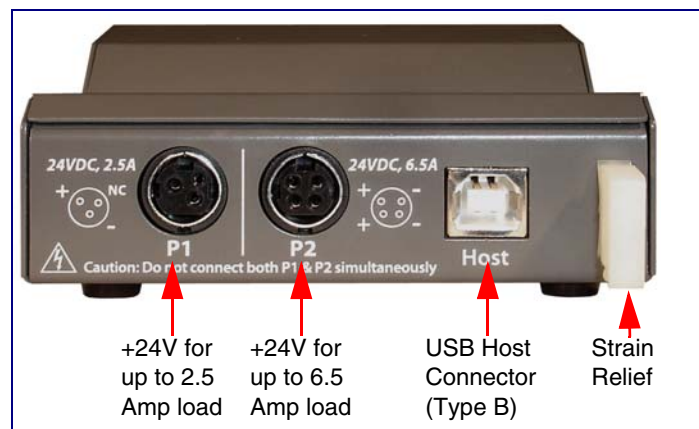

2.4.2 Host Connector

The connection to the host computer is achieved via a standard USB 2.0 certified Hi-Speed “A” to “B” cable that is included in the Accessory Kit, or with any equivalent USB 2.0 certified Hi-Speed cable. Refer to the [Section 2.1, "Product Components List"](#) for information about the Accessory Kit.

Figure 2-7. Host connector with strain relief

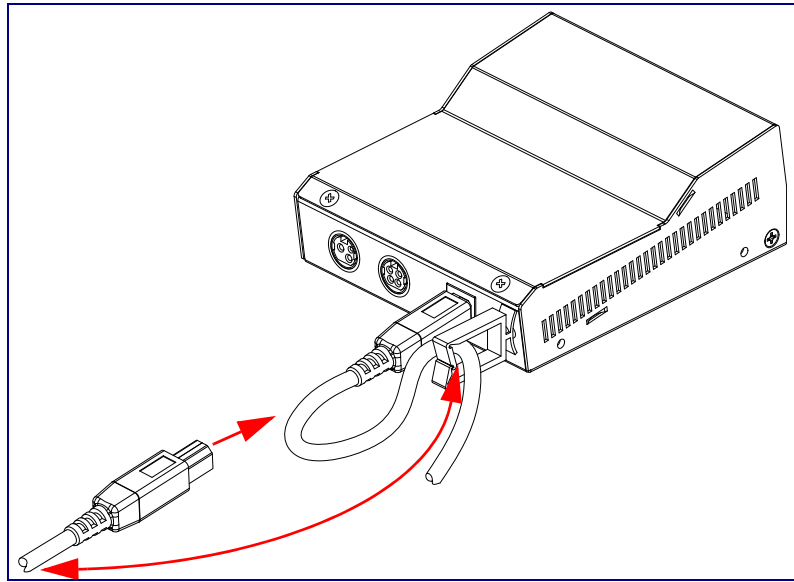

2.4.3 PoweredUSB Connections

The PoweredUSB connections are standard USB “A” connectors with four extra pins to supply higher voltages. See [Figure 2-9](#) for an illustration. The lower portion of the “A” connector side on this product can be used alone, without the locking PoweredUSB connector.

2.4.4 Connector Color Keys

The PoweredUSB connectors are color keyed so that *only* the correct voltage cables can be installed.

Figure 2-8. Color-Coding for Connectors

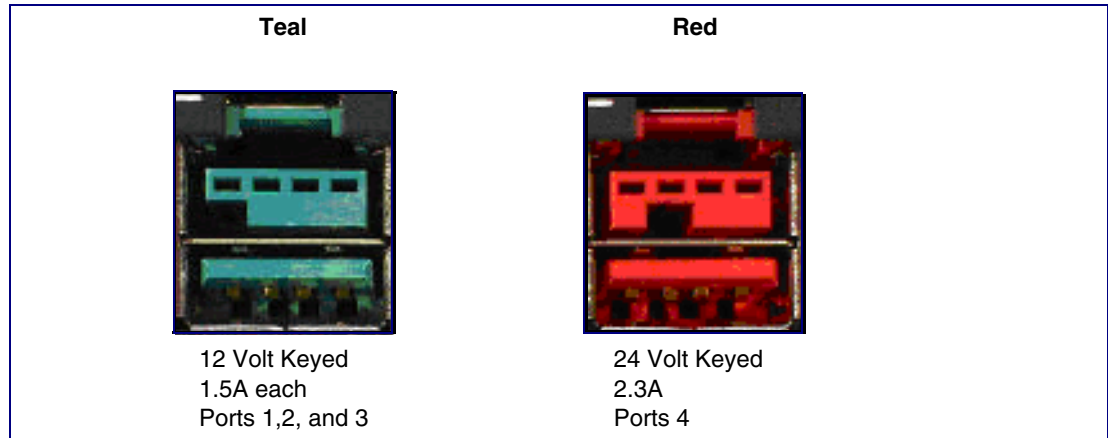
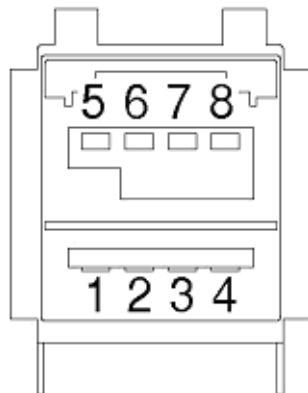

Figure 2-9. USB PoweredUSB Socket Connector Pin Assignments



PIN OUT		
Pin	Signal Description	
1	Vbus	USB standard "A"
2	D-	USB standard "A"
3	D+	USB standard "A"
4	Ground	USB standard "A"
5	Ground	USB PlusPower
6	Vplus	USB PlusPower
7	Vplus	USB PlusPower
8	Ground	USB PlusPower
Shell	Shield	

2.4.5 Peripherals Connections to the SiP VoIP and PoE Speaker

This figure illustrates the cable routing from the SiP VoIP and PoE Speaker to the Dell Retail Integrator.

Figure 2-10. Top view of Hub PoweredUSB cable routing

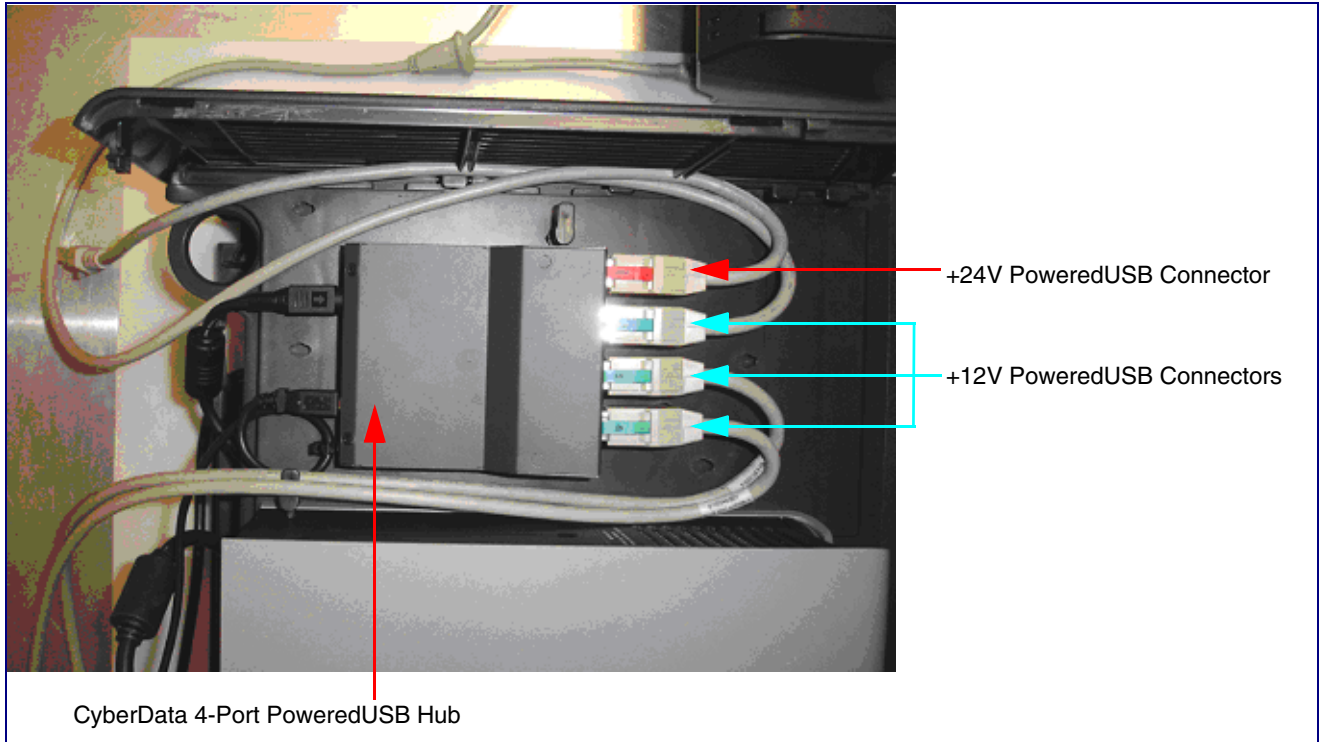

2.4.6 Peripheral Cable Connection Options

Figures 10 through 16 provide examples of peripheral cable combinations and connection options for the SiP VoIP and PoE Speaker. The following table provides details about the CyberData PoweredUSB Cables displayed in these figures.

PoweredUSB cable Custom cables of different lengths and colors can be purchased from CyberData as follows:
sources

- Via email: sales@cyberdata.net
- Via phone: Sales (831) 373-2601 Extension 334

Table 3. CyberData PoweredUSB Cables

Figure	PoweredUSB Cable Description	CyberData Part Number
Figure 2-11	12V to 2x4	010693C
Figure 2-12	12V to 12V Power Jack	Contact CyberData
Figure 2-13	24V PoweredUSB to 3-Pin Power Mini-DIN	010631A
Figure 2-14	24V to “Y” Cable 3-Pin Power Mini-DIN to USB “B”	010714A
Figure 2-15	12V to “Y” Cable, RS232 and Power Jack	010763
Figure 2-16	24V to 1x8	010617A
Figure 2-17	24V to “Y” Cable, RS232 and Power Jack	

Figure 2-11. Cable, +12V PoweredUSB to 2x4 PoweredUSB



Figure 2-12. Cables; +12V PoweredUSB to +12V Power Jack and RS-232 to RS-232

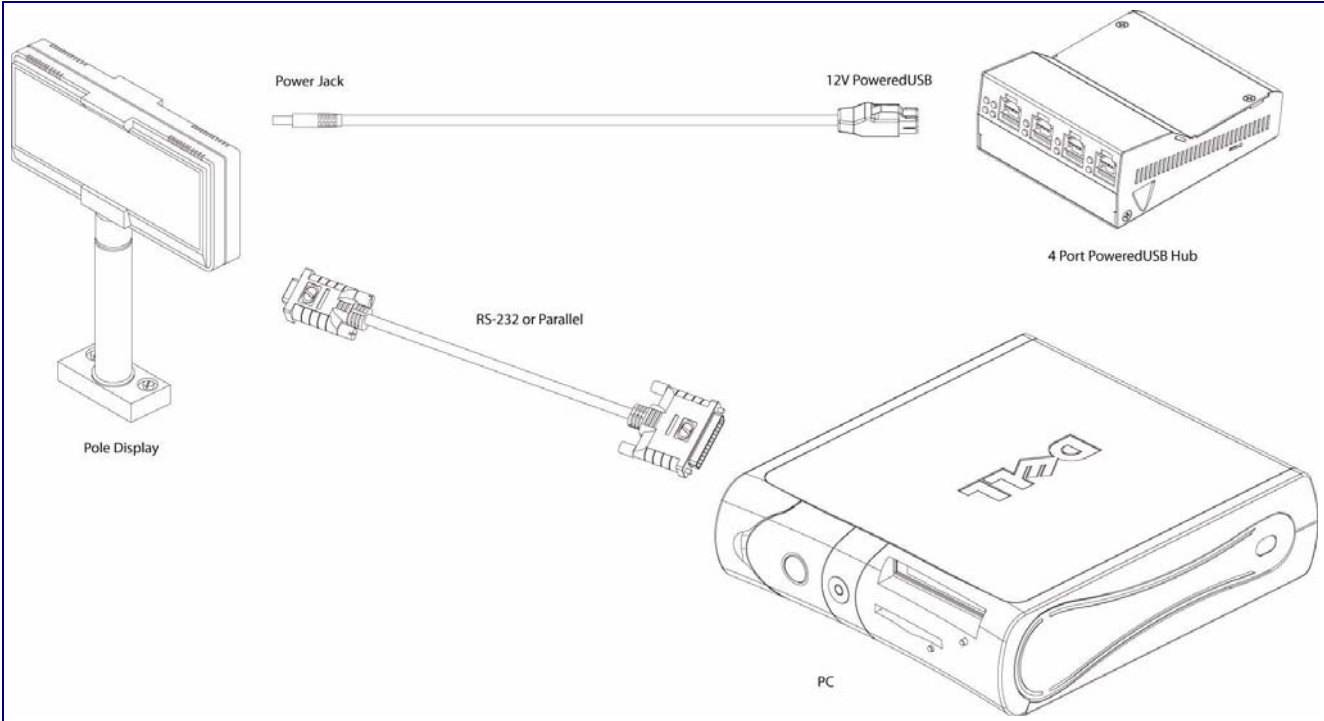

Figure 2-13. Cables; +24V PoweredUSB to 3-Pin Mini-DIN and RS-232 to RS-232 or Parallel to Parallel

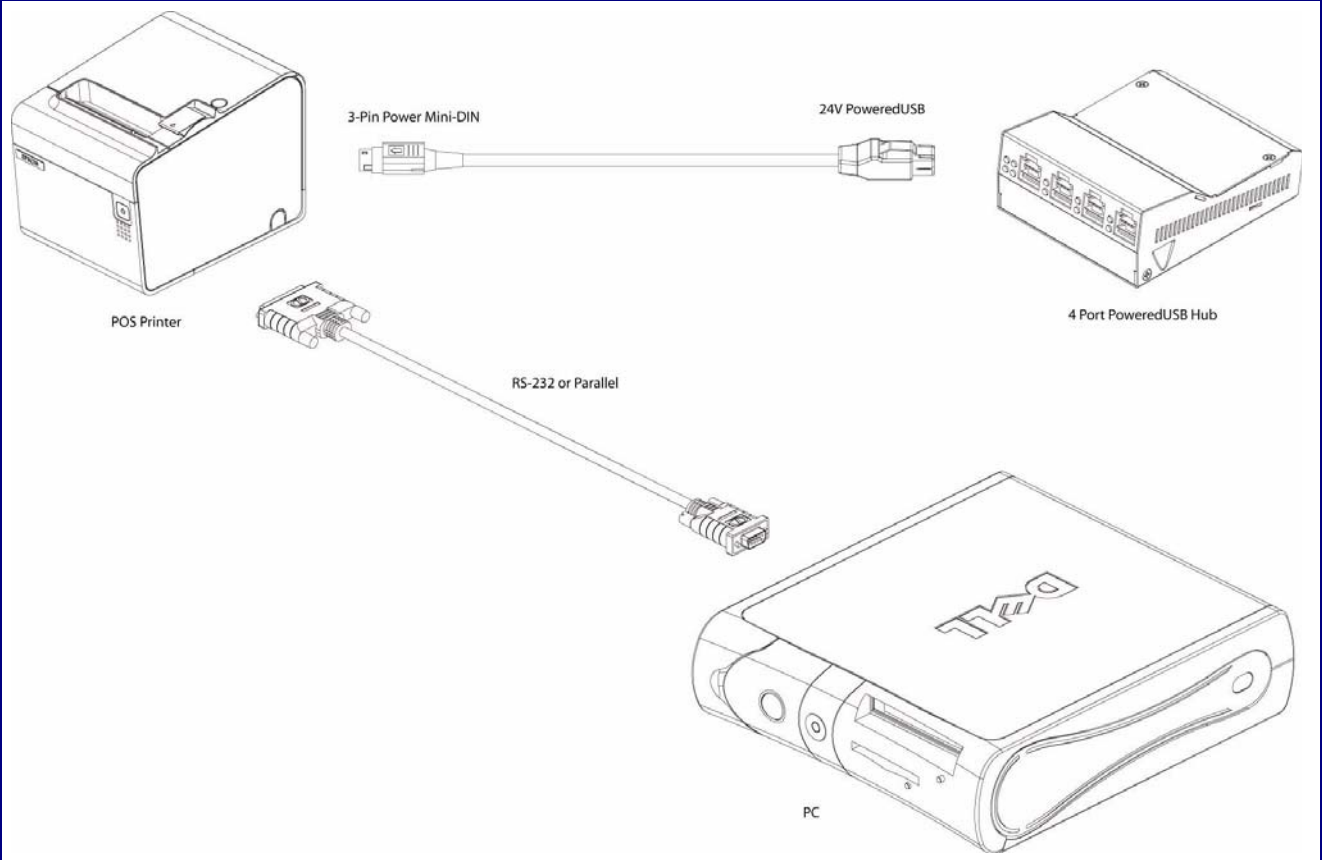

Figure 2-14. “Y” Cable, +24V PoweredUSB to 3-Pin Power Mini-DIN and USB “B” Connectors

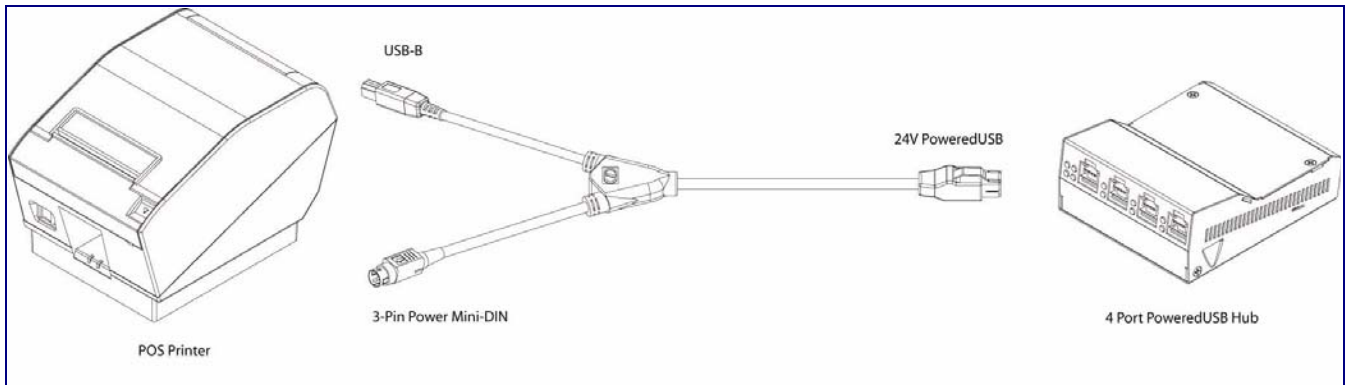

Figure 2-15. RS232 to USB Converter “Y” Cable +12V (PC Enumerates this device as an RS-232 COM port)

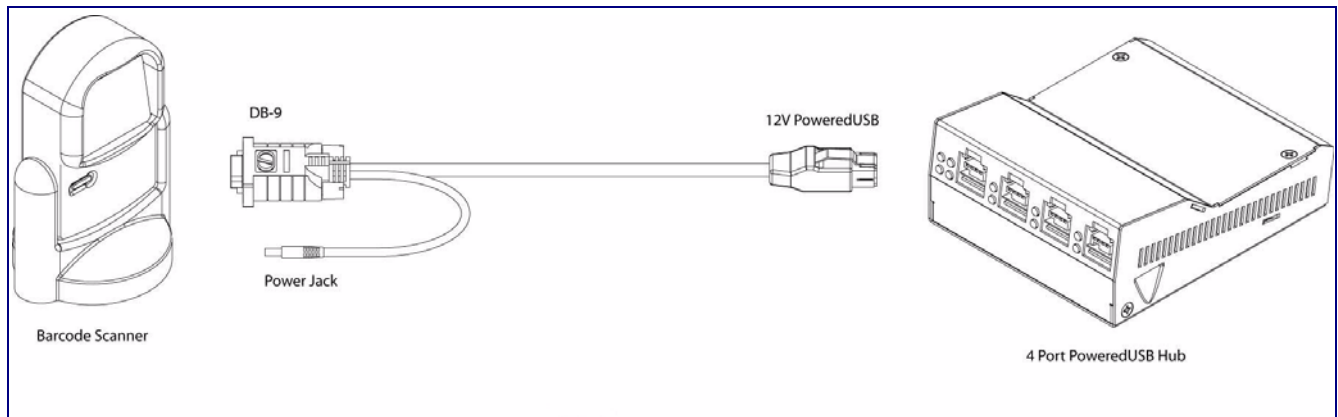

Figure 2-16. Cable, +24V PoweredUSB to 1x8 PoweredUSB

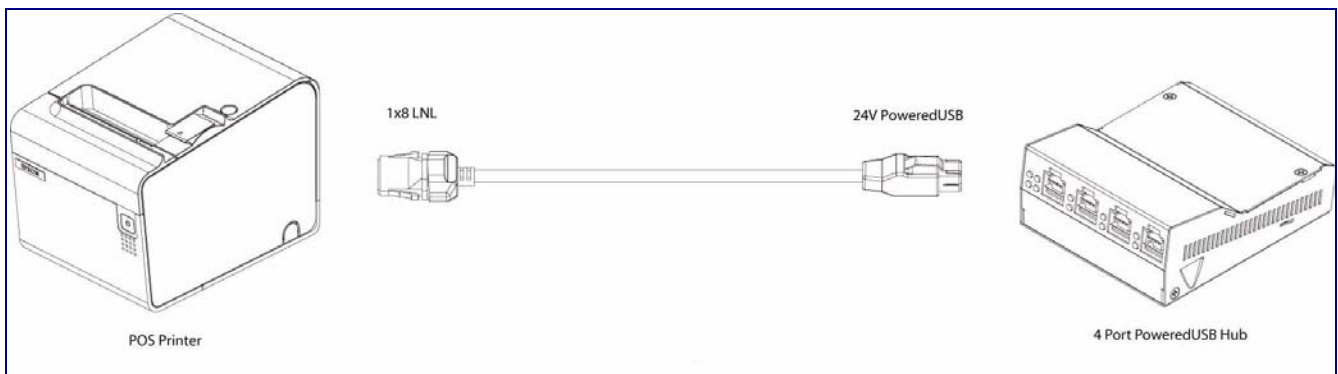
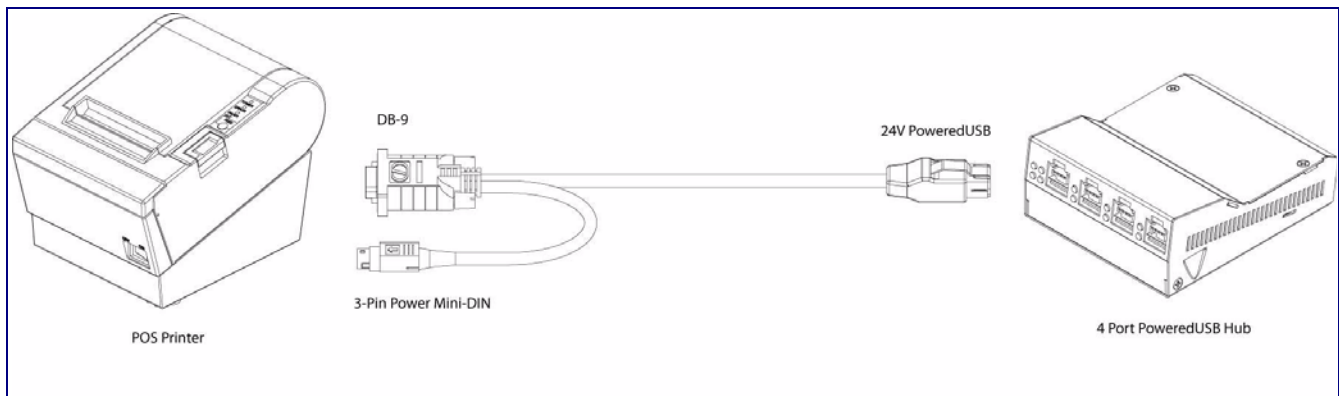

Figure 2-17. RS232 to USB Converter “Y” Cable +24V

2.5 Operation

The SiP VoIP and PoE Speaker is a standard USB Hub that complies with the USB 2.0 specification, and adds PoweredUSB ports. When connected to a Host, it is enumerated as a *Generic USB Hub*. This Hub also meets the PoweredUSB .08g specification. For more information about this specification, go to www.poweredusb.org.

2.5.1 POS Peripheral Caveat

According to the USB 2.0 specification, devices attached to a USB interface should enumerate from the Hub's USB Vbus, regardless of the PoweredUSB powered ports. Some POS devices do not comply with this specification, and will not enumerate unless the upper sections of the PoweredUSB ports are active.

When running on operating systems such as Windows XP with *no* devices attached (an empty Hub), the operating system turns the Hub off. The operating system does not detect non-compliant peripherals when they are hot-plugged into an empty Hub. Consequently PoweredUSB power is not supplied to the peripheral. In this case, you can restore correct operation as follows.

1. Unplug the Host side connection for five seconds, and then plug it in again.
2. Be sure that at least one USB device is plugged in when the computer is booted, or leaves standby mode.
3. Plug in a standard USB compliant device, such as a mouse or keyboard.
4. Disable the low-power, standby operation. With this configuration, power is always supplied to the PoweredUSB ports regardless of the PC's operational state. For more information, contact CyberData as instructed in [Appendix C, "Troubleshooting/Technical Support"](#).

2.6 Port Electrical Specifications

The SiP VoIP and PoE Speaker adheres to the USB 2.0 electrical specifications as follows:

2.6.1 Standard USB lower A supply

Each lower portion of the PoweredUSB port provides +5V @ 500mA. If more than 500mA are drawn from a port, that port goes into USB over current, the +5 volts is turned off, and the condition is reported to the host according to USB 2.0 specifications.

2.6.2 PoweredUSB supply

The listed maximum currents depend on the selected power supply. Both the +12V and +24V PoweredUSB ports are protected with active over current circuits. If an over current condition occurs, unplug the DC connection, remove the overcurrent condition, and re-cycle the DC connection to the Hub by unplugging it, and then plugging it in again.

- +12V Ports (3) – 1.5A each
- +24V Port (1) – 2.3A

Appendix A: Regulatory and Safety Information

Regulatory standards	<p>FCC Statement: This equipment has been tested and found to comply with the limits for a Class A digital device, pursuant to Part 15 of the FCC Rules. These limits are designed to provide reasonable protection against harmful interference when the equipment is operated in a commercial environment. This equipment generates, uses, and can radiate radio frequency energy and, if not installed and used in accordance with the instruction manual, may cause harmful interference to radio communications. Operation of this equipment in a residential area is likely to cause harmful interference in which case the user will be required to correct the interference at his own expense.</p>
Safety standards	<ul style="list-style-type: none"> ● UL60950-1; Information Technology Equipment ● CSA C22.2 No. 60950-01, Information Technology Equipment ● EN60950-1, Information Technology Equipment ● IEC60950-1, Information Technology Equipment
EMC	<p>For the USA and Canada, this device complies with:</p> <ul style="list-style-type: none"> ● Title 47 of the CFR, Part 15, Subpart B, Section 15.107(b) ● Title 47 of the CFR, Part 15, Subpart B, Section 15.109 (b) ● ICES-003
CE Declaration of Conformity	<p>This device complies with:</p> <ul style="list-style-type: none"> ● Directive 89/336/EEC ● EN55022 Class A 1998 <ul style="list-style-type: none"> • EN61000-3-2: 2000 • EN61000-3-3: 1995 ● EN55024: 1998 <ul style="list-style-type: none"> • EN61000-4-2: 1995 • EN 61000-4-3:1996 • EN 61000-4-4: 1995 • EN 61000-4-5: 1995 • EN 61000-4-6: 1996 • EN 61000-4-8: 1993 • EN 61000-4-11: 1995

Appendix B: Setting up the Hub on Windows XP

For connecting the SiP VoIP and PoE Speaker to a PC running the Windows XP operating system, keep in mind:

1. Microsoft XP Service Pack 1 or higher must be installed.
2. When connecting the Hub for the first time, it is important to perform the enumeration correctly. A Microsoft XP Service Pack issue does not enumerate and recognize a Hub when no devices are attached to it. To correctly enumerate the SiP VoIP and PoE Speaker, attach a peripheral whose drivers are included in Windows XP, such as a USB mouse, prior to enumerating the Hub. To accomplish this:
 - a. Connect a USB mouse to one of the lower, standard USB, Hub ports.
 - b. Connect the power cord to the Hub.
 - c. With the PC powered up, connect the host control cable from the Hub to a USB port on the PC. Doing so displays the *Found new hardware* dialog, indicating that the PC is searching for drivers for the Hub.
 - d. When the PC completes the driver search, it displays the *Found new hardware* dialog, in search of a driver for the mouse. If required, click **Next** in all screens of the wizard to complete the driver selection for the mouse.

At this point, you should be able to plug in and install a USB device provided you have also installed its drivers, or have them available for installation.

Appendix C: Troubleshooting/Technical Support

C.1 Frequently Asked Questions (FAQ)

Go to the following URL to see CyberData's list of frequently asked questions:

<http://www.cyberdata.net/support/pusb/4portpub.html>

C.2 Documentation

The documentation for this product is released in an English language version only. You can download PDF copies of CyberData product documentation at:

www.CyberData.net—>Support—>Drivers, Utilities & Manuals—>PoweredUSB, 4 Port Hub

C.3 Contact Information

Contact	CyberData Corporation 2555 Garden Road Monterey, CA 93940 USA www.CyberData.net Phone: 800-CYBERDATA (800-292-3732) Fax: 831-373-4193
Sales	Sales 831-373-2601 Extension 334
Technical Support	Phone: 831-373-2601 Extension 333 Email: support@CyberData.net
Returned Materials Authorization	To return the product, contact the CyberData Returned Materials Authorization (RMA) department at: Phone: 831-373-2601, Extension 136 Email: RMA@CyberData.net

When returning a product to CyberData, an approved CyberData RMA number must be printed on the outside of the original shipping package. No product will be accepted for return without an approved RMA number. Send the product, in its original package, to the following address:

CyberData Corporation
2555 Garden Road
Monterey, CA 93940
Attention: RMA "your RMA number"

C.4 Warranty

CyberData warrants its product against defects in material or workmanship for a period of two years from the date of purchase. Should the product fail within the warranty period, CyberData will repair or replace the product free of charge. This warranty includes all parts and labor.

If the product is out-of-warranty and fails, a flat rate repair charge of one half the product purchase price will be assessed. Repair costs for products that are in warranty, but damaged by improper modifications or abuse, will be charged at the out-of-warranty rate. Products returned to CyberData, both in and out-of-warranty, are shipped to CyberData at the expense of the customer. Charges for shipping repaired products back to the customer will be paid by CyberData.

Index

A

accessory kit 5, 8
active over current circuits. 15

C

cable routing 10
cable strain relief clamp 5
cables for connecting peripherals 11
CE conformity 16
CFR 16
color keys for ports 9
compatibility matrix 6
components list 5
connector color keys 9
CyberData
 license with IBM 2
CyberData contact information, corporate, sales, tech
 support, service 18

D

DC input jacks 7
Dell printer power supply 7

E

EMC 16
enumeration 14, 17
Epson PS180 brick 7

F

FCC 16
features 1

G

generic USB hub 14

H

high-current power supply 7
host connector 5, 8

I

IBM 2
ICES 16
Information Technology Equipment 16
installation 6

L

license 2

M

Microsoft XP Service Pack 1 17

O

over current protection 1

P

peripheral connections 11
power supply connections 7
PoweredUSB .08g specification 14
PoweredUSB connections 8
product
 accessory kit 5, 8
 CE conformity 16
 compatibility matrix 6
 components list 5
 enumerating 14
 enumeration 17
 features 1
 installation 6
 regulatory standards 16
 resell/release conditions 2
product compatibility 6

R

regulatory standards 16
resetting the IP address to the default 18
RMA returned materials authorization 18

S

short circuit protection 1

T

technical support, contact information 18

U

USB
 2.0 specification 14
 over current 15

W

warranty 1, 19
Windows XP 14, 17