



**WELLS BLOOMFIELD, LLC**  
2 ERIK CIRCLE, P. O. Box 280 Verdi, NV 89439  
telephone: 775-689-5703  
fax: 775-689-5976  
[www.wellsbloomfield.com](http://www.wellsbloomfield.com)

504



*Model WV-4HSRW*

## OPERATION MANUAL

## WV-4H SERIES

**HOTPLATE  
COOKTOP  
with  
UNIVERSAL  
HOOD**

**MODELS:  
WV-4HF  
WV-4HFRW  
WV-4HFRWT  
WV-4HS  
WV-4HSRW  
WV-4HSRWT**

**Includes  
INSTALLATION  
USE & CARE**

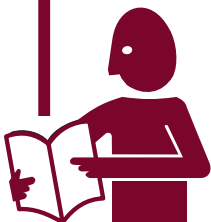

### **IMPORTANT: DO NOT DISCARD THIS MANUAL**

This manual is considered to be part of the appliance and is to be given to the OWNER or MANAGER of the restaurant, or to the person responsible for TRAINING OPERATORS of this appliance. Additional manuals are available from your WELLS DEALER.

**THIS MANUAL MUST BE READ AND UNDERSTOOD BY ALL PERSONS USING OR INSTALLING THIS APPLIANCE.** Contact your WELLS DEALER if you have any questions concerning installation, operation or maintenance of this equipment.

PRINTED IN UNITED STATES OF AMERICA

## LIMITED WARRANTY STATEMENT

Unless otherwise specified, all commercial cooking equipment manufactured by WELLS BLOOMFIELD, LLC is warranted against defects in materials and workmanship for a period of one year from the date of original installation or 18 months from the date of shipment from our factory, whichever comes first, and is for the benefit of the original purchaser only.

THIS WARRANTY IS THE COMPLETE AND ONLY WARRANTY, EXPRESSED OR IMPLIED IN LAW OR IN FACT, INCLUDING BUT NOT LIMITED TO, WARRANTIES OF MERCHANTABILITY OR FITNESS FOR ANY PARTICULAR PURPOSE, AND/OR FOR DIRECT, INDIRECT OR CONSEQUENTIAL DAMAGES IN CONNECTION WITH WELLS BLOOMFIELD PRODUCTS. This warranty is void if it is determined that, upon inspection by an authorized service agency, the equipment has been modified, misused, misapplied, improperly installed, or damaged in transit or by fire, flood or act of God. It also does not apply if the serial nameplate has been removed, or if service is performed by unauthorized personnel. The prices charged by Wells Bloomfield for its products are

based upon the limitations in this warranty. Seller's obligation under this warranty is limited to the repair of defects without charge by a Wells Bloomfield factory authorized service agency or one of its sub-service agencies. This service will be provided on customer's premises for non-portable models. Portable models (a device with a cord and plug) must be taken or shipped to the closest authorized service agency, transportation charges prepaid, for service. In addition to restrictions contained in this warranty, specific limitations are shown in the Service Policy and Procedure Guide. Wells Bloomfield authorized service agencies are located in principal cities. This warranty is valid in the United States and Canada and void elsewhere. Please consult your classified telephone directory, your foodservice equipment dealer or contact:

**Service Department, Wells Bloomfield, LLC  
P.O. Box 280, Verdi, Nevada 89439  
phone (775) 689-5707 or fax (775) 689-5976**

for information and other details concerning warranty.

## SERVICE POLICY AND PROCEDURE GUIDE and ADDITIONAL WARRANTY EXCLUSIONS

1. Resetting of safety thermostats, circuit breakers, over load protectors, and/or fuse replacements are **not** covered by this warranty unless warranted conditions are the cause.
2. All problems due to operation at **voltages or phase other than specified on equipment nameplates** are **not** covered by this warranty. Conversion to correct voltage and/or phase must be the customer's responsibility.
3. All problems due to **electrical connections not made in accordance with electrical code requirements and wiring diagrams** supplied with the equipment are **not** covered by this warranty.
4. Replacement of items **subject to normal wear**, to include such items as knobs, light bulbs; and, normal maintenance functions including adjustments of thermostats, adjustment of micro switches and replacement of fuses and indicating lights are **not** covered by warranty.
5. Damage to electrical cords and/or plug due to exposure to excessive heat are **not** covered by this warranty.
6. Full use, care, and maintenance instructions supplied with each machine. Noted maintenance and preventative maintenance items, such as servicing and cleaning schedules, are customer responsibility. Those miscellaneous adjustments noted are customer responsibility. Proper attention to preventative maintenance and scheduled maintenance procedures will prolong the life of the appliance.
7. Travel mileage is limited to **sixty (60) miles** from an Authorized Service Agency or one of its sub-service agencies.
8. All labor shall be performed during regular working hours. Overtime premium will be charged to the buyer.
9. All genuine Wells replacement parts are warranted for ninety (90) days from date of purchase on non-warranty equipment. This parts warranty is limited only to replacement of the defective part(s). **Any use of non-genuine Wells parts completely voids any warranty.**
10. Installation, labor, and job check-outs are **not** considered warranty and are thus **not** covered by this warranty.
11. Charges incurred by delays, waiting time or operating restrictions that hinder the service technician's ability to perform service are **not** covered by warranty. This includes institutional and correctional facilities.

## SHIPPING DAMAGE CLAIM PROCEDURE

**NOTE:** For your protection, please note that equipment in this shipment was carefully inspected and packaged by skilled personnel before leaving the factory. Upon acceptance of this shipment, the transportation company assumes full responsibility for its safe delivery.

### IF SHIPMENT ARRIVES DAMAGED:

1. **VISIBLE LOSS OR DAMAGE:** Be certain that any visible loss or damage is noted on the freight bill or express receipt, and that the note of loss or damage is signed by the delivery person.
2. **FILE CLAIM FOR DAMAGE IMMEDIATELY:** Regardless of the extent of the damage.

3. **CONCEALED LOSS OR DAMAGE:** if damage is unnoticed until the merchandise is unpacked, notify the transportation company or carrier immediately, and file "CONCEALED DAMAGE" claim with them. This should be done within fifteen (15) days from the date the delivery was made to you. Be sure to retain the container for inspection.

Wells Bloomfield cannot assume liability for damage or loss incurred in transit. We will, however, at your request, supply you with the necessary documents to support your claim.

## TABLE OF CONTENTS

WARRANTY .....	xi
SPECIFICATIONS .....	1
FEATURES & OPERATING CONTROLS .....	2
PRECAUTIONS & GENERAL INFORMATION .....	6
AGENCY LISTING INFORMATION .....	7
INSTALLATION .....	8
OPERATION .....	12
CLEANING INSTRUCTIONS .....	17
MAINTENANCE SCHEDULES .....	21
MSDS (Ansulex Low pH) .....	24
TROUBLESHOOTING SUGGESTIONS .....	26
PARTS & SERVICE .....	27
CUSTOMER SERVICE DATA .....	27

## INTRODUCTION

Thank You for purchasing this Wells Bloomfield appliance.

Proper installation, professional operation and consistent maintenance of this appliance will ensure that it gives you the very best performance and a long, economical service life.

This manual contains the information needed to properly install this appliance, and to use and care for the appliance in a manner which will ensure its optimum performance.

## SPECIFICATIONS

MODEL	ROLL WARMER	VOLTS 50/60 Hz	3 $\phi$ AMPS			1 $\phi$ AMP S	WATTS	DIMENSIONS POWER CORD
			L1	L2	L3			
WV-4HF	NO	208V	16	15	26	30	6,300	30-1/4" WIDE (42-1/4" wide including spacers) 77-1/4" HIGH 35-1/2" DEEP Power Cord (when provided): NEMA 15-60P
		240V	18	17	30	35	8,300	
WV-4HFRW WV-4HFRWT	YES	208V	19	15	30	34	7,000	
		240V	27	22	43	48	11,600	
WV-4HS	NO	208V	20	19	34	39	8,100	
		240V	23	22	39	45	10,700	
WV-4HSRW WV-4HSRWT	YES	208V	19	15	30	34	7,000	
		240V	22	17	34	38	9,200	

Minimum clearances required from unit to nearest combustible surface or object

	BACK	SIDE	BOTTOM	TOP
inches	n/a	6	6	19
millimeters	n/a	152	152	483

# FEATURES & OPERATING CONTROLS

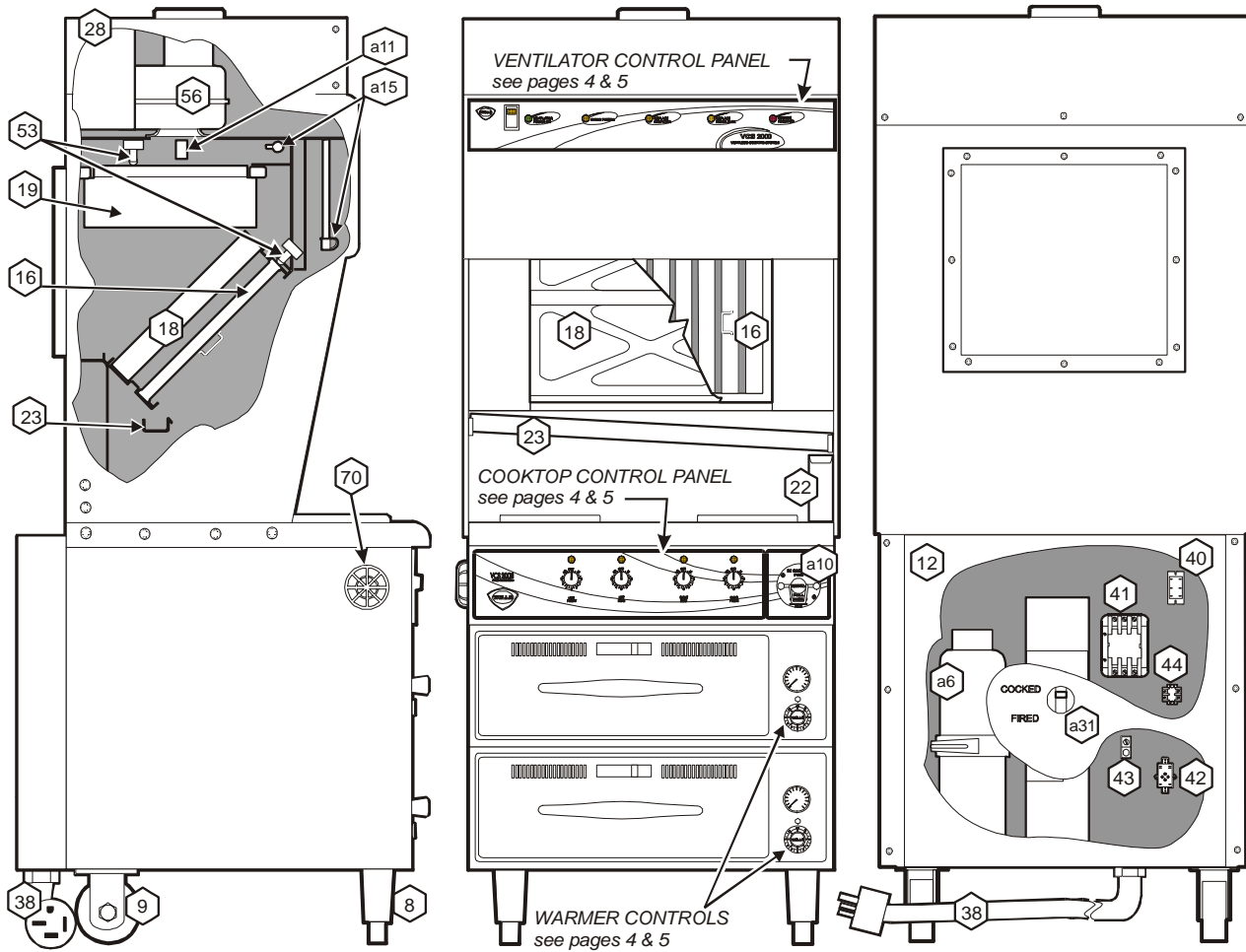

Fig. 1 Ventilator Section Operating Features & Controls

504 p/n 303903 opM WV-4H Ventilless Hotplate Cooktop

## FEATURES & OPERATING CONTROLS (continued)

### VENTILATOR SECTION

ITEM	DESCRIPTION	COMMENT
a6.	FIRE SUPPRESSION AGENT TANK (1.5 gal.)	Container for Ansul <sup>TM</sup> Low-pH liquid fire suppression liquid.
8.	ADJUSTABLE (FRONT) LEG	Allows the unit to be leveled.
9.	RIGID (REAR) CASTER	Allows the unit to be easily positioned by lifting the front of the unit slightly.
a10.	MANUAL PULL STATION	Provides a means of manual activation of the fire suppression system. <b>PULL ONLY IN CASE OF FIRE!</b>
a11.	FUSIBLE LINKS	Automatically activates fire suppression system in the event of fire on the cooktop.
12.	LOWER REAR ACCESS PANEL	Allows access to Ansul <sup>®</sup> fire suppression agent tank (a6) and controls also access to main power contactor (41).
a15.	DISCHARGE NOZZLE	Fire suppression media discharges here (2 places).
16.	GREASE BAFFLE	Extracts and drains most grease and moisture from the air flow.
18.	PRE-FILTER ASSEMBLY	Comprises the PRE-FILTER FRAME and a replaceable PRE-FILTER. Stops larger particles of grease from reaching the FILTER PACK for reduced maintenance costs.
19.	HEPA/CHARCOAL FILTER PACK	Stops most grease and smoke particles. Also assists in some cooking odor removal.
22.	GREASE CUP	Collects grease/moisture drained from grease trough (23).
23.	GREASE TROUGH	Directs grease/moisture removed by grease baffle to grease cup.
28.	VENTILATOR EXHAUST DUCT	Exit point for ventilator airflow - on top left rear of unit. <b>DO NOT BLOCK</b>
a31.	STATUS INDICATOR	Displays status of fire suppression system ( <i>COCKED - FIRED</i> ) If <i>FIRED</i> , a buzzer will sound continuously.
38.	POWER CORD	6' cord and cap. Plug for NEMA 15-60R (receptacle by user).
40.	WARMER RELAY	Provides power to roll warmer section. Energized at all times except during fire safety shut-down.
41.	POWER CONTACTOR	Energizes cooktop only while ventilator section is sensed as operational.
42.	BUILDING FIRE ALARM RELAY	Reports fire alarm condition to building fire management system.
43.	GROUND LUG	Ground wire of power cord connects here.
44.	INTERLOCK TERMINAL	Provides connection for shut-down control by building fire management system.
56.	VENTILATOR FAN	Provides air movement for ventilation.
70.	COOLING FAN	Provides cooling for cooktop controls.

## FEATURES & OPERATING CONTROLS (continued)

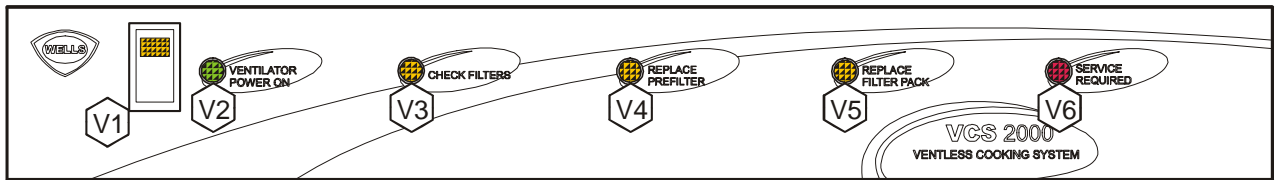

Fig. 2 Ventilator Section Controls & Indicator Lights

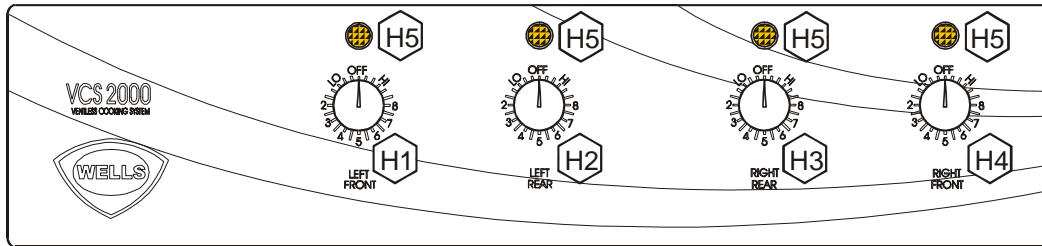

Fig. 3 Cooktop Section Controls & Indicator Lights

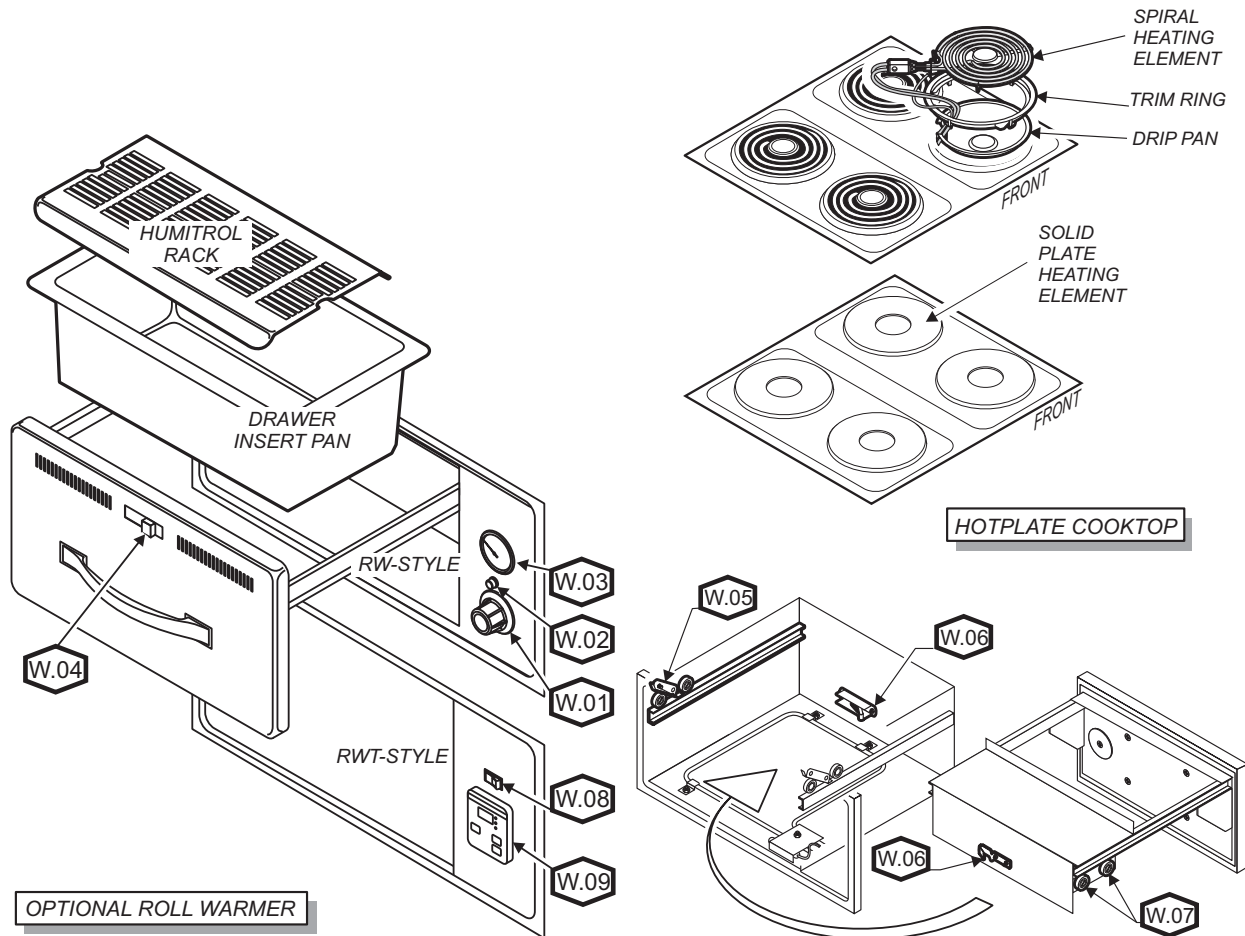

Fig. 4 Cooktop & Warmer Drawer Operating Features & Controls

## FEATURES & OPERATING CONTROLS (continued)

ITEM	DESCRIPTION	COMMENT
------	-------------	---------

### VENTILATOR SECTION CONTROLS

V1	POWER SWITCH	<b>Energizes blower motor. If, after 10 seconds, proper conditions are met, cooktop is energized.</b>
V2	POWER ON INDICATOR	GREEN. Glows when POWER switch is ON.
V3	CHECK FILTERS ALARM INDICATOR	AMBER. Glows if one or more filters are out of position. Check all filters and baffles for proper installation.
V4*	REPLACE PREFILTER ALARM INDICATOR	AMBER. Glows when PREFILTER is approaching the end of its service life and must soon be replaced.
V5*	REPLACE FILTER PACK ALARM INDICATOR	AMBER. Glows when FILTER PACK is approaching the end of its service life and must soon be replaced.
V6*	SERVICE REQUIRED ALARM INDICATOR	RED. Glows when PREFILTER and/or FILTER PACK has reached the end of its service life and is too loaded to allow sufficient air flow. Filter <b>MUST</b> be replaced. Appliance is <b>SHUT DOWN</b> until expended filters are replaced.

### COOKTOP SECTION CONTROLS

H1	LEFT FRONT HOTPLATE CONTROL	Infinite switch control of temperature of one hotplate section.
H2	LEFT REAR HOTPLATE CONTROL	Infinite switch control of temperature of one hotplate section.
H3	RIGHT REAR HOTPLATE CONTROL	Infinite switch control of temperature of one hotplate section.
H4	RIGHT FRONT HOTPLATE CONTROL	Infinite switch control of temperature of one hotplate section.
H5	POWER ON INDICATOR	AMBER. Glows when temperature control is turned ON.

### OPTIONAL WARMER SECTION CONTROLS

W.01	TEMPERATURE CONTROL	Infinite switch control of temperature of one warmer drawer.
W.02	POWER ON INDICATOR	AMBER. Glows when associated temperature control is turned ON.
W.03	THERMOMETER (optional)	Reads temperature inside drawer cavity Must be ordered at time of initial build.
W.04	HUMIDITY CONTROL	Slide control of shutters to control air circulation within the warmer drawer.
W.05	DRAWER CATCH	Holds drawer closed.
W.06	DRAWER STOP	Prevents drawer from opening too far. Spring loaded to permit easy removal of drawer.
W.07	DRAWER ROLLERS	Support drawer and allow it to open and close smoothly.
W.08	POWER SWITCH (RWT)	Energizes unit (RWT-style only)
W.09	CONTROLLER	Controls cavity temperature. Readout displays setpoint and actual temperature information. UP ARROW / DOWN ARROW keys allow modification of setpoint temperature. (RWT-style units only)

504 p/n 303903 opM WV-4H Ventless Hotplate Cooktop



## PRECAUTIONS AND GENERAL INFORMATION



### **WARNING: ELECTRIC SHOCK HAZARD**

All servicing requiring access to non-insulated electrical components must be performed by a factory authorized technician.

DO NOT open any access panel which requires the use of tools. Failure to follow this warning can result in severe electrical shock.



### **CAUTION: RISK OF DAMAGE**

DO NOT connect or energize this appliance until all installation instructions are read and followed. Damage to the appliance will result if these instructions are not followed.

**NOTE:** Fire suppression system and all associated components must only be serviced by an authorized Ansul® Distributor. All setup, charging, repair and/or adjustment of the fire suppression system must be performed by an **Authorized Ansul® Distributor ONLY**.

**IMPORTANT:** If a remote pull station is installed, both rear casters (9) must be replaced with legs to deter moving the unit. **MOVING AN APPLIANCE WITH A REMOTE PULL STATION WILL DISCHARGE THE FIRE SUPPRESSION SYSTEM.**

This Ventless Cooking System™ is designed to help reduce odor emissions, but will not completely eliminate cooking odors. Air exchange at the installation site must comply with the requirements of the local jurisdictional authority. To ensure that odors do not build-up, recommended minimum air exchange is 300 - 400 cfm of outside air into *and out of* the area where the unit is used. Recommend use of wall fan (GRAINGER # 4C707) and wall switch (Grainger #4C254), to be supplied by user.

This appliance is intended for use in commercial establishments only.

This appliance is intended to prepare food for human consumption. No other use is recommended or authorized by the manufacturer or its agents.

Operators of this appliance must be familiar with the appliance use, limitations and associated restrictions. Operating instructions must be read and understood by all persons using or installing this appliance.

Cleanliness of this appliance is essential to good sanitation. Read and follow all included cleaning instructions and schedules to ensure the safety of the food product.

Disconnect this appliance from electrical power before performing any maintenance or servicing.

Do not splash or pour water on, in or over any exposed element, control, control panel or wiring.

DO NOT submerge pre-filter or filter pack in water.

The technical content of this manual, including any wiring diagrams, schematics, parts breakdown illustrations and/or adjustment procedures, is intended for use by qualified technical personnel.

Any procedure which requires the use of tools must be performed by a qualified technician.

This manual is considered to be a permanent part of the appliance. This manual and all supplied instructions, diagrams, schematics, parts breakdown illustrations, notices and labels must remain with the appliance if it is sold or moved to another location.

This appliance is made in the USA. Unless otherwise noted, this appliance has American sizes on all hardware.



## PRECAUTIONS AND GENERAL INFORMATION (continued)

### OPERATIONAL NOTES:

*REPLACE PREFILTER* and *REPLACE FILTER PACK* indicator lights provide a timely warning that a system shut-down is imminent.

The actual time between the indicator light coming on and the loss of cooking appliance power will depend upon the cooking conditions.

Anytime a dirty PRE-FILTER is replaced, the system airflow will increase. If the condition of the FILTER PACK is marginal, the *REPLACE FILTER PACK* light could then come on. If this happens, a fresh FILTER PACK must be installed within a reasonably short time.

Loss of airflow through the old filter pack will soon cause a system shut-down when the airflow falls below minimum vapor capture levels.

### **KEEP SPARE FILTER PACKS ON HAND.**

**IMPORTANT:** If you decide to “get the most” out of the old filter pack, and continue to use it until a system shut-down happens, it is advisable to have a fresh filter pack readily at hand, and have someone available who is capable of replacing it. Otherwise, you may experience an extended down time, with consequent associated loss of business.

**The manufacturer assumes no liability for loss of business due to a system shutdown caused by a dirty pre-filter and/or filter pack (i.e. red *SERVICE REQUIRED* light is on), when the user fails to have the proper replacement pre-filter and/or filter pack on hand.**

The Ventless Cooking System™ hood is designed as part of a **WELLS cooktop appliance** only. No other use of this product is authorized by the manufacturer or its agents. Wells Mfg. assumes no liability for the use of this equipment with products by any other manufacturer's, or for use of this equipment with any Wells Manufacturing product other than in factory certified applications.

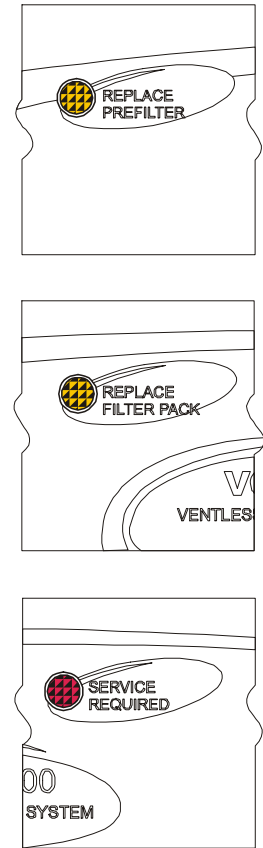

Fig. 5 Ventilator Warning Indicators

## AGENCY LISTING INFORMATION

This appliance conforms to NSF Standard 4 for sanitation only if installed in accordance with the supplied *Installation Instructions* And operated and maintained in accordance with the instructions in this manual.

This appliance is  Listed under UL File E146882.



STD 4



E146882

## INSTALLATION

**NOTE:** DO NOT discard the carton or other packing materials until you have inspected the appliance for hidden damage and tested it for proper operation. Refer to *SHIPPING DAMAGE CLAIM PROCEDURE* on the inside front cover of this manual.



### **WARNING: RISK OF INJURY**

Installation procedures must be performed by a qualified technician with full knowledge of all applicable electrical codes. Failure can result in personal injury and property damage.

## UNPACKING & INSPECTION

Carefully remove the appliance from the carton. Remove all protective plastic film, packing materials and accessories from the Appliance before connecting electrical power or otherwise performing any installation procedure.

Carefully read all instructions in this manual and the *Installation Instruction Sheet* packed with the appliance before starting any installation.

Read and understand all labels and diagrams attached to the appliance.

Carefully account for all components and accessories before discarding packing materials. Store these components in or near the appliance for later use. To prevent loss, these items should be installed as soon as possible.

1 ea. FIRE SUPPRESSION AGENT (**ANSULEX® Low pH**, 1.5 GAL.)  
See *Material Safety Data Sheet*, page 22.

1 ea. FIRE SUPPRESSION MEDIA TANK

1 ea. FIRE SUPPRESSION TANK CHARGING CARTRIDGE

1 ea. GREASE BAFFLE

1 ea. FILTER PACK ASSEMBLY

1 ea. PRE-FILTER HOLDER with PRE-FILTER

1 ea. GREASE CUP

1 ea. GREASE TROUGH

2 ea. 6" SIDE SPACERS

1 ea. LITERATURE PACKAGE

Additionally:

2 ea. DRAWER INSERTS (if ordered with warmer drawers)

4 ea. HOTPLATE DRIP PANS (if ordered with spiral elements)

4 ea. ELEMENT SUPPORTS (if ordered with spiral elements)

## SETUP

Setup the appliance only on a firm level surface. Non-combustible material is recommended.

Refer to the *Installation Instruction Sheet* for required clearances. Maintain required clearances between the appliance and adjacent combustible surfaces. Verify 6" left and right side clearances to combustible construction. This appliance requires a **minimum of 8 ft (96")** (floor to overhead) to allow for adequate exhaust.

Verify that the VENTILATOR HOOD ASSEMBLY is properly and securely assembled to the cooking appliance before beginning the installation procedure.

***If a remote manual pull station is to be installed, replace the rear casters with legs.***

Level the unit after it is in its final position. Using a spirit level, verify that the unit is level front-to-back and side-to-side.

Avoid storing flammable or combustible materials near the appliance.

### SERVICE TECHNICIAN INSTALLATION NOTES

An Ansul® technician must charge and arm the fire suppression system before the ventilator blower will operate. See page 10.

Installation and start up must be performed by an Authorized Installation Company.

Installer must complete the *WARRANTY REGISTRATION* form, and record appliance installation particulars on the *CUSTOMER SERVICE DATA* form in this manual.

Certain codes require cooking equipment to be restrained with a RESTRAINT DEVICE. It is the RESPONSIBILITY OF THE INSTALLER to check with the AUTHORITY HAVING JURISDICTION, in order to ascertain the applicability of this requirement to THIS SPECIFIC EQUIPMENT INSTALLATION. Any restraint device must allow access to the back and sides of the unit to provide for servicing and maintenance, and must not interfere with the operation of the FIRE SUPPRESSION SYSTEM.

### ELECTRICAL INSTALLATION

Refer to the nameplate on the cooking appliance to verify the ELECTRICAL SERVICE POWER. Voltage and phase must match the nameplate specifications, and available electrical service amperage must meet or exceed the specifications listed on page 1. Incoming wiring must comply with National Electrical Code specifications.

All cooktop / universal hood appliances ship from the factory wired 3ø and include a 3ø cordset.

For 1ø operation:

- a. Remove rear lower panel (item 12)
- b. Refer to the wiring schematic diagram located on the inside of the panel.
- c. Service wiring and conduit, or appropriate cordset must be provided by the electrical installer.
- d. Wiring change must be performed by a licensed electrician.
- e. Be sure to reinstall the panel when wiring change is completed.

### IMPORTANT!

Verify that this VENTILATOR and food cooking equipment installation is in compliance with the specifications listed in this manual, with local code requirements, and in accordance with N.F.P.A 96 (*THE STANDARD FOR VENTILATION CONTROL AND FIRE PROTECTION OF COMMERCIAL COOKING OPERATIONS* - current edition).

THIS IS THE  
RESPONSIBILITY  
OF THE INSTALLER



### DANGER ELECTRIC SHOCK HAZARD

ELECTRIC CONNECTIONS MUST BE MADE BY A LICENSED ELECTRICIAN. Electrical shock will cause death or serious injury.

NOTE: This appliance requires a dedicated 60 Amp electrical branch circuit protection.

### IMPORTANT:

Contact a licensed electrician to install and connect electrical power to the appliance.

### IMPORTANT:

Damage due to being connected to the wrong voltage or phase is NOT covered by warranty.

## INSTALLATION (continued)



THE FIRE SUPPRESSION SYSTEM MUST BE CHARGED AND CERTIFIED BY AN AUTHORIZED **ANSUL®** DISTRIBUTOR. **NEVER** ATTEMPT TO MODIFY OR BYPASS THE FIRE SUPPRESSION SYSTEM. AN UNCONTROLLED FIRE CAN CAUSE SERIOUS INJURY, DEATH AND/OR PROPERTY LOSS.

**IMPORTANT:** The FIRE SUPPRESSION SYSTEM must be SET-UP and CHARGED by an authorized **Ansul®** distributor before the ventilator blower will operate.

**NOTE:** If the fire suppression system is discharged, a buzzer will sound continuously and the cooking appliance will remain inoperable until the fire suppression system is serviced. **Recharging and resetting must be performed by an authorized Ansul® distributor ONLY.**

Charging of the Ansul Fire Suppression system must be in accordance with *Ansul® Design, Installation, Recharge and Maintenance Manual*. (Ansul® #418087-05)

## FIRE SUPPRESSION SYSTEM INSTALLATION

1. Any REMOTE MANUAL PULL STATION must be installed by an authorized ANSUL® distributor in accordance with the AUTHORITY HAVING JURISDICTION.

**NOTE:** If a REMOTE MANUAL PULL STATION is installed, moving the unit for servicing will cause the **Ansul®** system to discharge. In this case, the unit must only be installed with four fixed legs (i.e. remove rear casters and replace with legs). Additional legs may be ordered through an Authorized Wells Service Agency. See page 25.

2. The FIRE SUPPRESSION SYSTEM is comprised of a pressurized cartridge & container of liquid fire suppressant, with associated plumbing and controls. It utilizes factory installed FUSIBLE LINKS for automatic actuation, and a factory installed MANUAL PULL STATION for manual actuation. Two NOZZLES are used to disperse the liquid fire suppression media.

3. When the fire suppression system activates, the fire suppression media is discharged, both the cooking appliance and the ventilator are de-energized, and a buzzer will sound continuously. The fire suppression media will form an emulsion designed to both smother and cool the fire.

**Call your Authorized Ansul® Distributor immediately for service.**

**NOTE:** See page 22 for the Material Safety Data Sheet for the fire suppression agent.

4. The MANUAL PULL STATION and any similar REMOTE MANUAL PULL STATION will activate the fire suppression system when the ring on the pull station is pulled horizontally.

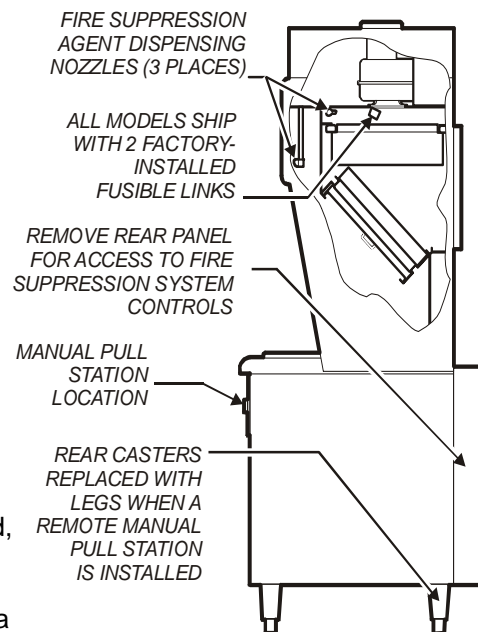

Fig. 6 Fire Suppression System

## FILTERS INSTALLATION

- FILTER PACK:** Ships installed in the hood. If the FILTER PACK is not in position, the *CHECK FILTERS* indicator will light. If the FILTER PACK becomes clogged, the *REPLACE FILTER PACK* indicator will glow.

To install the FILTER PACK: Position the filter pack with the charcoal portion UP. Slide the filter pack toward the rear of the unit until it contacts the guides on the back panel. Push the filter pack UP into the upper opening until it rests firmly against the filter pack seal. When up in position, holder clips can be snapped over wall ledge on each side. To remove FILTER PACK: Grasp both holder clips and pull INWARD until the clips clear the sidewall ledge. Then, pull the filter pack down and out.
- PRE-FILTER:** The PRE-FILTER ships in the FILTER FRAME. If the PRE-FILTER is not in position, or if the PRE-FILTER is not in the FILTER FRAME, the *CHECK FILTERS* indicator will light. If the PRE-FILTER becomes clogged, the *REPLACE PRE-FILTER* indicator will glow.

To install the PRE-FILTER: Pay attention to the air flow markings. The *AIR FLOW* arrow will point away from the installer. Slide the assembly up into the front opening, behind the upper filter rail. While pressing slightly against the bottom of the assembly, pull the FILTER HANDLE toward you so as to engage the FILTER HOOK over the lip of the top filter rail. Then lower and seat the assembly into the top indentation of the lower filter rail.
- GREASE BAFFLE:** If the GREASE BAFFLE is not in place, the *CHECK FILTERS* indicator will glow.

To install the GREASE BAFFLE: Slide the grease baffle up into the indentation of the upper filter rail, then lower and seat it into the bottom indentation of the lower filter rail. Pull toward you and downward to verify the GREASE BAFFLE is properly seated in the lower frame rail.

### NOTE:

The GREASE BAFFLE and FILTER PACK activate mechanical switches, and the PRE-FILTER activates a vacuum switch, to verify that the filter elements are in their proper positions. All filter elements must be properly installed or the cooktop will not be energized. Also, the *CHECK FILTERS* indicator will light.

### IMPORTANT:

**The filter hook prevents the PRE-FILTER from being drawn in during operation.** After installation, press against the top of the filter frame to verify proper engagement of the filter hook over the lip of the top filter rail.

### IMPORTANT:

Protect the surface of ceramic cooktops from damage in the event a filter is accidentally dropped.

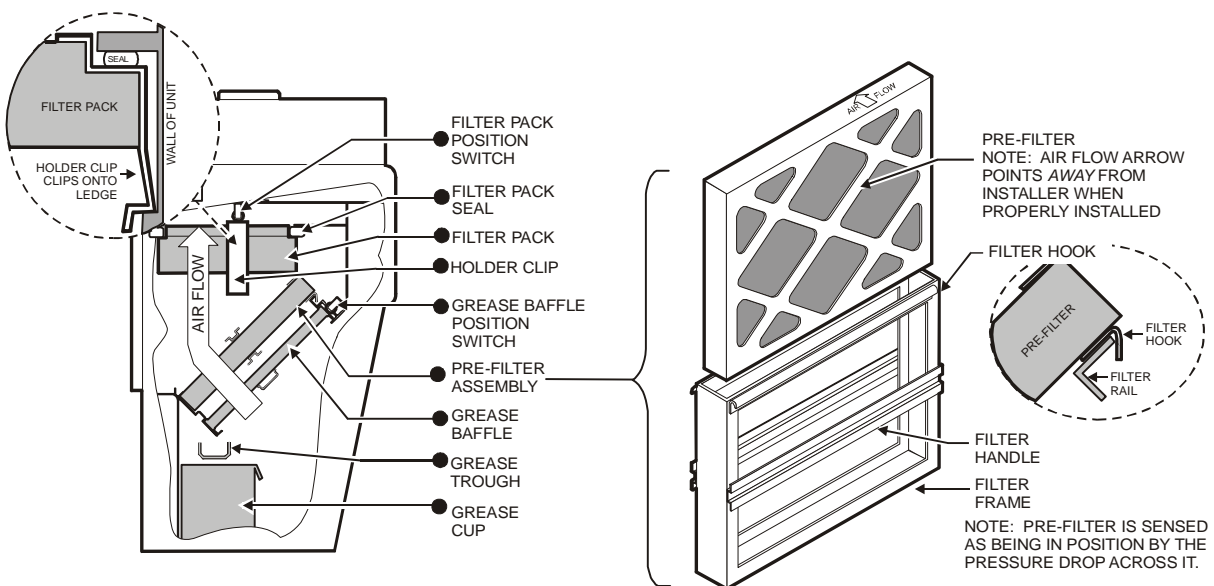

Fig. 7 Filter Installation

## INSTALLATION (continued)



**WARNING**  
SLIP / FALL  
HAZARD  
SPILLED OIL



DO NOT OPERATE UNLESS  
THE GREASE CUP IS  
INSTALLED.

Oil and moisture will drip onto  
the floor and falls may result.  
Death or serious injury may  
result from slipping and falling



**CAUTION:**  
BURN HAZARD



DO NOT OPERATE UNLESS  
GREASE TROUGH  
IS INSTALLED.

Moisture will drip into the hot  
cooking surface, causing  
splattering of hot liquids.  
Serious injury can result from  
contact with hot splatter.

## GREASE TROUGH AND GREASE CUP INSTALLATION

1. Install the GREASE TROUGH into the brackets below the grease baffle.
2. Install the GREASE CUP on the right side of the unit, directly below the grease trough.

## ROLL WARMER INSTALLATION

1. Be sure roller catches (inside warmer cavity) are in the open position. Install drawer assemblies in drawer slides.
2. Place appropriate one drawer insert pan into each warmer drawer. If used, place one Humitrol rack into each drawer pan.

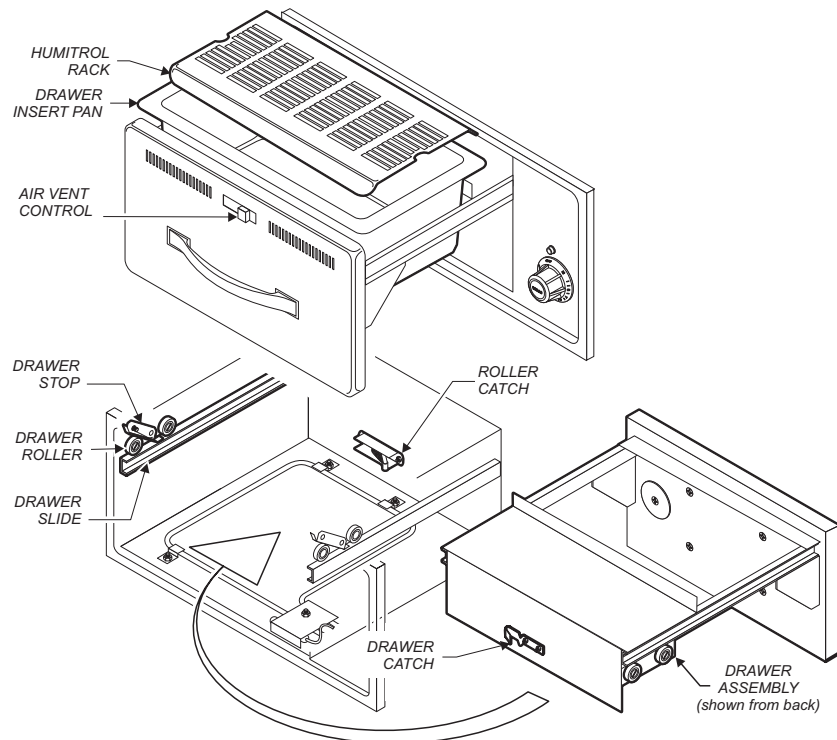

Fig. 8 Roll Warmer Drawer Pan Installation



**VENTILATOR OPERATION**

1. Press the VENTILATOR POWER switch to ON. The green VENTILATOR POWER light will glow and the blower fan will start. After a short time, if all filters are sensed as being in position and not clogged, the cooktop will be energized. The roll warmer is energized at all times. During normal operation, the VENTILATOR POWER light will be the only light glowing on the upper control panel.
2. If the amber CHECK FILTER light glows, one or more filter elements is out of position. Check the GREASE BAFFLE, PRE-FILTER and FILTER PACK for proper installation in their respective positions. Grease baffle and filter pack position are sensed by mechanical switches. Pre-filter position is sensed by a vacuum switch.
3. When the amber REPLACE PRE-FILTER light glows, the pre-filter is nearing the end of its service life. Replace the disposable PRE-FILTER ELEMENT.
4. When the amber REPLACE FILTER PACK light illuminates, the HEPA / Charcoal filter pack is nearing the end of its service life. Replace the FILTER PACK.

**Note:** The REPLACE PRE-FILTER and REPLACE FILTER PACK lights are a warning that the indicated filter is near the end of its service life. The appliance will continue to operate for a period of time after the light glows to allow continued operation through a peak period. However, the indicated filters must be replaced within a reasonably short time period or they will clog and shut down electrical power to the cooktop. The ventilator blower will continue to run.

5. When the red SERVICE REQUIRED light glows, either the pre-filter or filter pack (or both) is clogged and can no longer pass sufficient air to allow further operation. The ventilator fan continues to run, but the cooktop is shut down until the underlying clogged filter situation has been corrected. This can occur when neither CHANGE...FILTER indicator light is lit, if both pre-filter and filter pack are marginal. Replacing both the pre-filter and the filter pack will remedy the situation.

**Note:** replacing the pre-filter, even though not very dirty, will often extend the service life of the more expensive filter pack.

Reset the unit by turning the VENTILATOR POWER switch to OFF, then back ON.

6. A failure of incoming electrical power will cause a shut down of the unit. After power is restored, reset the unit by turning the VENTILATOR POWER switch to OFF, then back ON.



**CAUTION:  
HOT SURFACE**

Exposed surfaces can be hot to the touch and may cause burns.

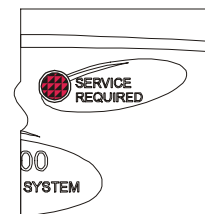
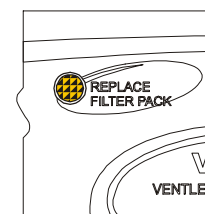
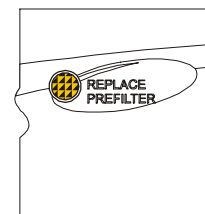
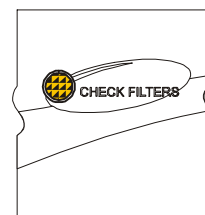
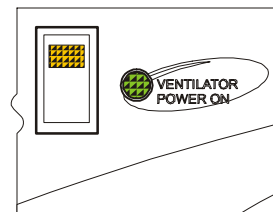

Fig. 9 Ventilator Indicator and Warning Lights

## OPERATION (continued)



### CAUTION: HOT SURFACE

Exposed surfaces can be hot to the touch and may cause burns.

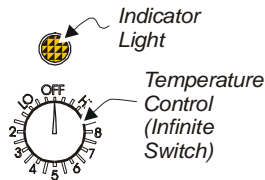

Fig. 10 Hotplate  
Temperature Control

#### IMPORTANT:

The dial markings are an INDICATION of temperature only. The temperature of the food product depends on many factors, including the size, shape and material of the food container, and the quantity and consistency of the food product.

## HOTPLATE COOKTOP OPERATION

### GENERAL OPERATIONAL NOTES

Carefully read the description of the hotplate operation on the specification sheet.

**DO NOT** attempt to perform any maintenance or service unless the hotplate is disconnected from electrical power.

**DO** turn the circuit breaker for the hotplate off before cleaning, servicing or performing any maintenance.

**DO NOT** use sharp objects or metal implements to clean the heating elements.

**DO** use a plastic spatula or plastic scouring pad to remove burned-on food product.

### OPERATION

Each heating element is controlled by an infinite switch temperature control:

OFF removes power from the element

LOW thru 8 are temperature settings

Higher numbers indicate higher temperatures

There is a continuous range of settings between LOW and HI

HI is a continuous ON setting

The indicator light will glow any time the temperature control is on.

On ceramic cooktops, the HOT SURFACE indicator will glow any time the control is on, or the surface is above 150°F.

### Cooking Recommendations:

Save energy by turning the temperature control off any time the hotplate is not in use. The coil-type and ceramic heating elements will provide full heat within 30 seconds, while solid plate heating elements will reach full heat within 2 minutes, making it unnecessary to leave the unit on during intermittent use.

Each heating element can hold up to a 16 quart pot or pan. For efficient heating of food product, pots and pans should be no more than 10" in diameter.

Maximize the efficiency of solid elements and ceramic cooktops by using flat-bottom pots and pans.

Stir thick liquids frequently to maintain a consistent temperature.

**DRAWER WARMER OPERATION**

**HEATING OPTIONS**

1. Moist heat with Humitrol Rack:
  - a. MOIST operation prevents food from drying out as moisture, as well as heat, is applied to the warming chamber.
  - b. To set for MOIST operation, remove Humitrol Rack from bottom of drawer insert pan and carefully pour approximately 2 quarts of water (½" depth) into the pan. Reinstall rack.
  - c. The Humitrol Rack decreases the sloshing effect of the water in the pan when the drawer is opened. When the drawer is closed, the Humitrol Rack allows steam to rise through the stored product in the drawer.
  - d. Place the food directly on the rack. The rack is designed to support the food off of the steam vents, where water droplets may form.
  - e. Check the water level in the pan periodically, and add water when necessary.
  - f. Set the front air vent between fully closed and half-open. Actual setting will depend upon the type and amount of product stored in the drawer, the temperature setting, and the frequency with which the drawer is opened.
  
2. Moist heat with pans:
  - a. This Wells warmer is designed to accommodate any combination of standard-size, steam table pans.
  - b. Place a small amount of water in drawer pan. Place pans in drawer pan.
  - c. Check the water level in the pan periodically, and add water when necessary.
  
3. Dry heat:
  - a. For some applications, you may want to store previously prepared foods in a dry-heat environment. To do so, place the food directly into the empty (i.e. no water) drawer pan.



**CAUTION:  
HOT SURFACE**

Exposed surfaces can be hot to the touch and may cause burns.

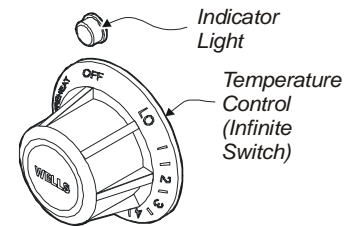

*Fig. 11 Roll Warmer Temperature Control*

**NOTE:**

The chart below is intended as a guide ONLY. Your own experience with this appliance, type of foods and method of operation will enable you to determine the temperature control and air vent settings best suited to your operation.

**OPERATING CHART FOR DRAWER WARMERS**

PRODUCT TYPE	RECOMMENDED STORAGE TEMP.	TYPE OF HEAT	CONTROL SETTING	AIR VENT SETTING
Hard Rolls	160-185°F	Dry	7-8	Closed
Soft Rolls	150-175°F	Moist	6-7	Open - ½
Vegetables	175-185°F	Moist	7-8	Open - ½
Meats	165-185°F	Dry	6-8	Closed
Fish	165-185°F	Moist	6-8	Open
Casseroles	150-175°F	Dry	6-7	Closed
Pies, Desserts	160-185°F	Dry	6-7	Closed

## OPERATION (continued)

### DRAWER WARMER OPERATION (when provided)

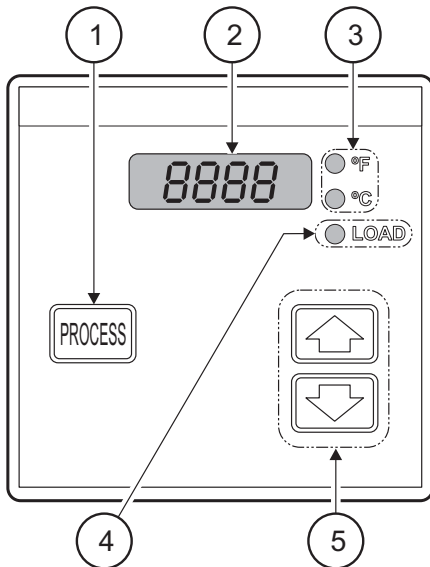

ITEM	DESCRIPTION
1	PROCESS Key: Press to view actual temperature of cavity.
2	4 Character LED Display: Normally shows SETPOINT temperature.
3	°F or °C Indicator: Glow to indicate if unit is configured for degrees Fahrenheit or degrees Celsius.
4	LOAD Indicator: Glow when heating element is energized.
5	Increment and Decrement Keys: Press UP arrow to increase Press DOWN arrow to decrease

#### RWT- CONTROL MODULE

#### SET SETPOINT TEMPERATURE

Press an arrow key:

UP arrow to increase

DOWN arrow to decrease

Release key when desired setpoint temperature is displayed.

Reading is locked into memory 3 seconds after last key stroke.

Minimum setpoint is 140°F (60°C)

Maximum setpoint is 250°F (121°C)

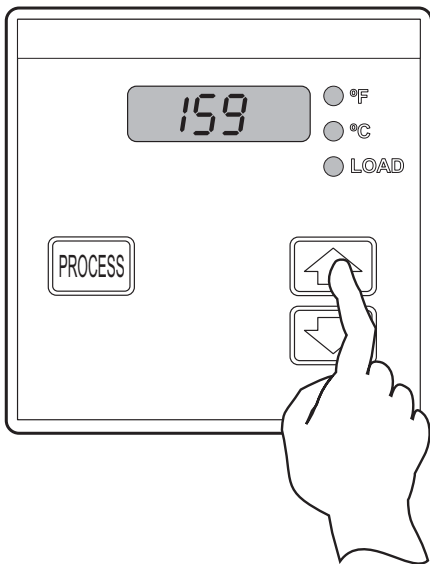

#### CHANGE DISPLAY MODE ( °F or °C)

Press and hold UP arrow and DOWN arrow keys for 10 seconds.

Release keys when display reads F C.

Within 3 seconds, press UP arrow or DOWN arrow key until desired indicator (°F or °C) glows.

The new value will lock into memory 3 seconds after last keystroke.

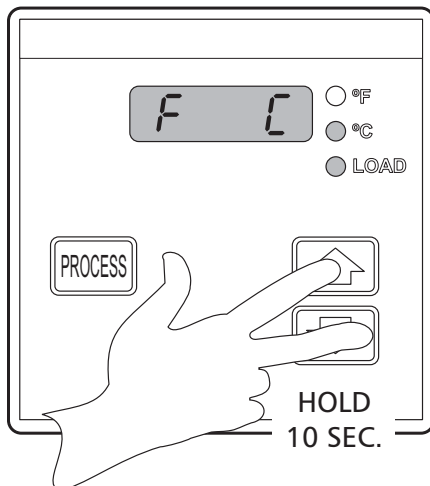

## CLEANING INSTRUCTIONS

### HOTPLATE COOKTOP DAILY CLEANING

**PREPARATION** Disconnect appliance from electric power  
Allow to cool before cleaning

**FREQUENCY** Daily

**TOOLS** Warm water and a mild detergent  
Soft clean cloth or sponge  
Plastic scouring pad, plastic scraper



**CAUTION:  
ELECTRIC  
SHOCK HAZARD**

Disconnect appliance from electric power before cleaning.



**CAUTION:  
HOT SURFACE**

Exposed surfaces can be hot to the touch and may cause burns. Allow appliance to cool before cleaning.

Disconnect appliance from electric power  
Allow to cool before cleaning

Spiral Hotplate Elements:

Raise elements. Remove and empty drip pans.

Drip pans and element supports may be washed in a sink or dishwasher. Allow to air dry and reinstall.

Scrape burned-on food debris from element using a plastic scraper or plastic scouring pad. **DO NOT** use steel wool or metal implements to clean elements.

Solid Plate Hotplate Elements:

Scrape burned-on food debris from element using a plastic scraper or plastic scouring pad. **DO NOT** use steel wool or metal implements to clean elements.

Wipe elements and counter top with a clean cloth or sponge dampened with warm water and a mild detergent. Rinse by wiping with a clean cloth or sponge dampened with warm water. Allow to air dry.

Procedure is complete.

**IMPORTANT:**

**DO NOT** spill or pour water into controls, control panel, wiring or coil-type hotplate elements. Damage to internal components will occur. Damage to internal components from water damage is **not** covered by warranty.

**IMPORTANT:**

**DO NOT** use steel wool or metal implements to clean hotplate elements.

## CLEANING INSTRUCTIONS (continued)



### CAUTION: ELECTRIC SHOCK HAZARD

Disconnect appliance from electric power before cleaning.



### CAUTION: HOT SURFACE

Exposed surfaces can be hot to the touch and may cause burns. Allow appliance to cool before cleaning.

### IMPORTANT:

Never allow PRE-FILTER or FILTER PACK to get wet. DO NOT wash either of these two filters. Washing these filters will ruin them and cause the appliance to shut-down.

### IMPORTANT:

DO NOT spill or pour water into controls, control panel, wiring or coil-type hotplate elements. Damage to internal components will occur. Damage to internal components from water damage is **not** covered by warranty.

### IMPORTANT:

DO NOT use steel wool or metal implements to clean cabinet surfaces.

## VENTILATOR WEEKLY CLEANING

**PREPARATION:** Disconnect appliance from electric power  
Allow to cool before cleaning

**FREQUENCY:** Weekly

**TOOLS:** Warm water and a mild detergent  
Soft clean cloth or sponge  
Bristle brush  
Container for disposal of grease

1. Remove the grease baffle, pre-filter assembly, grease trough and grease cup. Empty the grease trough and grease cup.
2. Remove the pre-filter from the filter frame. Wash and rinse the filter frame **ONLY**.
3. Wash and rinse the grease baffle, grease trough and grease cup in a sink or dishwasher using mild detergent and warm water. Allow to air dry.
4. Reinsert the pre-filter into the filter frame. Reinstall the pre-filter, grease baffle, grease trough and grease cup.

Procedure is complete



## CLEANING INSTRUCTIONS (continued)

### VENTILATOR MONTHLY CLEANING

**PREPARATION:** Disconnect appliance from electric power  
Allow to cool before cleaning

**FREQUENCY:** Monthly

**TOOLS:** Warm water and a mild detergent  
Soft clean cloth or sponge  
Plastic scouring pad, plastic scraper  
Container for disposal of grease



**CAUTION:  
ELECTRIC  
SHOCK HAZARD**

Disconnect appliance from electric power before cleaning.



**CAUTION:  
HOT SURFACE**

Exposed surfaces can be hot to the touch and may cause burns. Allow appliance to cool before cleaning.

### EXTERIOR

Wash exterior surfaces with a soft clean cloth or sponge dampened with warm water, mild soap or detergent. Rinse with a soft clean cloth or sponge dampened with warm water. Allow to air dry.

### INTERIOR:

In addition to the weekly cleaning procedure, remove the filter pack.

Cover the griddle section. Wash the interior surfaces of the ventilator with warm water, mild soap or detergent and a clean, soft cloth or sponge. Stubborn or burned-on food debris may be removed with a plastic scouring pad or plastic scraper.

Dry thoroughly with a clean soft cloth.

Uncover the griddle and reassemble the ventilator.

Procedure is complete.

### IMPORTANT:

Never allow PRE-FILTER or FILTER PACK to get wet. DO NOT wash either of these two filters. Washing these filters will ruin them and cause the appliance to shut-down.

### IMPORTANT:

DO NOT spill or pour water into controls, control panel, wiring or coil-type hotplate elements. Damage to internal components will occur. Damage to internal components from water damage is **not** covered by warranty.

### IMPORTANT:

DO NOT use steel wool or metal implements to clean cabinet surfaces.

## CLEANING INSTRUCTIONS (continued)



### CAUTION: ELECTRIC SHOCK HAZARD

Disconnect appliance from electric power before cleaning.



### CAUTION: HOT SURFACE

Exposed surfaces can be hot to the touch and may cause burns. Allow appliance to cool before cleaning.

### IMPORTANT:

DO NOT spill or pour water into controls, control panel, wiring or coil-type hotplate elements. Damage to internal components will occur. Damage to internal components from water damage is **not** covered by warranty.

### IMPORTANT:

DO NOT use steel wool or metal implements to clean drawers or cabinet surfaces.

### DRAWER WARMER DAILY CLEANING

**PRECAUTIONS:** Turn control knob to OFF.  
Allow drawers to cool before proceeding.  
Remove drawer pans and Humitrol racks.

**FREQUENCY:** Minimum -Daily

**TOOLS:** Warm water and mild detergent  
Clean cloth or sponge

1. Remove drawers from warmer:
  - a. Pull warmer drawer out until fully extended.
  - b. Slide finger along left and right slide rail until you reach the latches (located at the front end of the cabinet-mounted rails). Press down on both left and right latch.
  - c. Pull drawer away from warmer.

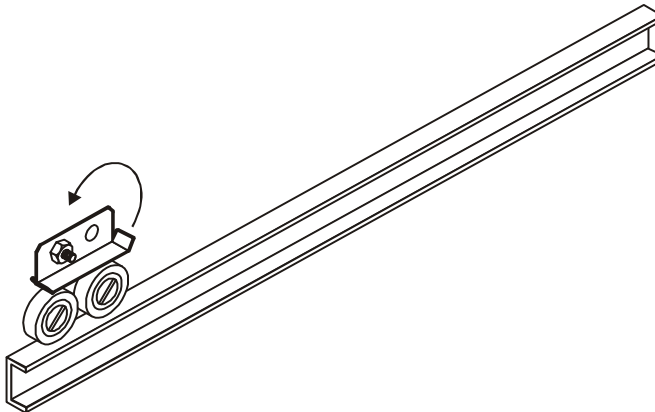

2. Clean drawers, drawer pans, Humitrol Racks and/or insets with warm water and mild detergent. Rinse all components thoroughly with clear water. Dry all components prior to reinstalling them in warmer.
3. Sweep crumbs and other debris from warmer cavity.
4. Clean the outside of the unit by wiping with a clean cloth or sponge, warm water and mild detergent. Dry with a clean cloth, then wipe with a polish formulated for stainless steel.
5. It is important to keep the slide rails clear and free from debris. Periodic cleaning of the slide rails and other adjoining parts is necessary to assure smooth drawer operation.
6. Check drawer rollers. Be sure they roll freely and that the slide rails are free from debris.
7. Be sure cabinet-mounted drawer catch roller is "up", then re-install drawers.

## MAINTENANCE SCHEDULES

### 1. 6-MONTH MAINTENANCE (MUST BE PERFORMED BY AN AUTHORIZED ANSUL® DISTRIBUTOR ONLY):

- a. Inspect and test total operation including FIRE DAMPER and all SAFETY INTERLOCKS.
- b. All FIRE SUPPRESSION SYSTEM actuation components including MANUAL PULL STATION and any REMOTE MANUAL PULL STATION must be inspected for proper operation in accordance with the maintenance schedule published in *ANSUL® R-102 SYSTEM DESIGN, INSTALLATION, RECHARGE AND MAINTENANCE MANUAL* (Ansul® #418087-05).
- c. The FIRE SUPPRESSION SYSTEM FUSIBLE LINKS must be inspected. NOZZLES and MANUAL PULL STATION must be cleaned in accordance with *ANSUL® R-102 SYSTEM DESIGN, INSTALLATION, RECHARGE AND MAINTENANCE MANUAL* (Ansul® #418087-05).
- d. The FIRE SUPPRESSION AGENT TANK, PIPING and FLEXIBLE TUBING must be INSPECTED.

### 2. 12-YEAR MAINTENANCE: (MUST BE PERFORMED BY AN AUTHORIZED ANSUL® DISTRIBUTOR ONLY):

- a. The FIRE SUPPRESSION AGENT TANK and ¼" FLEX HOSE must be HYDROSTATICALLY TESTED, and the FIRE EXTINGUISHING AGENT must be REPLACED in accordance with the maintenance schedule published in *ANSUL® R-102 SYSTEM (STANDARD UL 300 LISTED)*.
- b. The FUSIBLE LINKS in plenum and damper must be REPLACED. This maintenance to be performed by qualified **Ansul®** service personnel only.

USE AND MAINTENANCE SHALL BE IN ACCORDANCE WITH THE *STANDARD FOR VENTILATION CONTROL AND FIRE PROTECTION OF COMMERCIAL COOKING OPERATIONS*, N.F.P.A 17A & N.F.P.A. 96 (current editions).



**DANGER  
FIRE  
HAZARD**

FAILURE TO PROPERLY CLEAN AND MAINTAIN THIS EQUIPMENT CAN CAUSE A FIRE. AN UNCONTROLLED FIRE CAN CAUSE SERIOUS INJURY, DEATH AND/OR PROPERTY LOSS.

NOTE: A signed and dated VENTILATOR HOOD MAINTENANCE LOG must be maintained on the premises, and shall be available for inspection by the authority having jurisdiction. See pages 20 & 21.

**IMPORTANT: Parts used for the Ansul® fire suppression system are not serviceable by the owner / operator.** Procedures for servicing fire suppression equipment are described in: *ANSUL® R-102 SYSTEM DESIGN, INSTALLATION, RECHARGE AND MAINTENANCE MANUAL* (Ansul® #418087-05).

Inspection shall be conducted on a monthly basis in accordance with the manufacturer's Operation Manual. At a minimum, this inspection shall include verification of the following:

**WELLS BLOOMFIELD, LLC**  
VENTILATOR HOOD OWNERS MONTHLY INSPECTION LOG

<b>OPERATION</b>	<b>AGENT / DATE</b>												
Extinguishing system components: In proper place and (visually) in good order													
Manual pull station actuators for fire suppression system are unobstructed													
The maintenance log is in place and up to date													
No obvious physical damage or condition exists that might prevent operation of the fire suppression system													
The nozzle blow-off caps are in place and in good condition													
The hood, duct and protected cooking appliance have not been replaced, modified or relocated													
Clean plenum GREASE BAFFLE and BLOWER (max. interval: 3 months)													
Change PRE-FILTER and FILTER PACK (as required)													

This MAINTENANCE LOG is to be performed and completed by a trained technician who has completed the instruction necessary to perform the maintenance and recharge service.

**WELLS BLOOMFIELD, LLC**  
**VENTILATOR HOOD MAINTENANCE LOG**

OPERATION		AGENT / DATE											
Clean and inspect discharge nozzle in plenum BEFORE filters Max. interval: 6 months													
Clean and inspect discharge nozzle in plenum AFTER filters Max. interval: 6 months													
Inspect fire suppression fuse links, all releasing devices for actuation, fire suppressant tank liquid level Max interval: 6 months (discharge of fire suppressant not a part of this test)													
Inspect fire suppression hoses, plumbing and tank for obstructions and any conditions such as, but not limited to, corrosion and pitting. Max. interval: 6 months													
Inspect and test all filter interlocks Max. interval: 6 months													
Replace 3 fire suppression links in hood plenum All models: 212°F	Log TEMP												
	Log Mfg DATE Stamp												
Replace fire damper fuse link Model WVF-886: 286°F Model WVG-136: 286°F Max interval: 12 months	Log TEMP												
	Log Mfg DATE Stamp												

THIS MAINTENANCE LOG MUST BE KEPT IN A PROTECTIVE COVER PERMANENTLY ATTACHED TO THE APPLIANCE  
 Log all repairs and recommendations on reverse side. Any repairs, other than replacement of factory authorized parts, to the fire suppression plumbing system must be subject to hydrostatic pressure testing.

ANSULEX Low pH  
QUICK IDENTIFIER (In Plant Common Name)

Manufacturer's Name: <b>ANSUL INCORPORATED</b>	Emergency Telephone No.: <b>CHEMTREC (800) 424-9300 or (703) 527-3887</b>
Address: One Stanton Street, Marinette, WI 54143-2542	Other Information Calls: (715) 735-7411
Prepared By: Safety and Health Department	Date Prepared: February 1, 1999

**SECTION 1 - IDENTITY**

Common Name (Used on Label): (Trade Name and Synonyms) <b>ANSULEX Low pH Liquid Fire Suppressant</b>	CAS No.: <b>N/A</b>
Chemical Name: <b>N/A This is a Mixture</b>	Chemical Family: <b>Mixture</b>
Formula: <b>N/A</b>	

**SECTION 2 - INGREDIENTS**

<b>PART A - HAZARDOUS INGREDIENTS</b>				
Principal Hazardous Component(s) (chemical and common name(s)):	Wt. %	CAS No.	ACGIH TLV	Acute Toxicity Data
None	N/A	N/A	N/A	N/A
<b>PART B - OTHER INGREDIENTS</b>				
Other Component(s) (chemical and common name(s)):	Wt. %	CAS No.	ACGIH TLV	Acute Toxicity Data
Proprietary Mixture of Organic and Inorganic Salts	48.0 - 50.0	N/A	N/E	NDA
Phosphoric Acid	0.2	7664-38-2	N/E	NDA
EDTA	0.65	64-02-8	N/E	NDA
Yellow-Green Fluorescent Dye	0.011	518-47-8	N/E	Oral LD <sub>50</sub> (rat) 6800 mg/kg
Water	Approx. 50.0	7732-18-5	N/E	NDA

**SECTION 3 - PHYSICAL AND CHEMICAL CHARACTERISTICS (Fire and Explosion Data)**

Boiling Point: 113°C	Specific Gravity (H <sub>2</sub> O=1): 1.33	Vapor Pressure (mm Hg): Not Determined
Percent Volatile by Volume (%): Approx. 50.0	Vapor Density: (Air = 1): 1.03	Evaporation Rate: (Butyl Acetate=1): Approx. 0.005
Solubility in Water: 100%	Reactivity in Water: Mild exothermic reaction	
Appearance and Odor: Fluorescent Yellow Colored Liquid, Mild Odor		
Flash Point: None to boiling	Flammable Limits in Air % by Volume: N/A	Extinguisher Media: N/A
		Auto-Ignition Temperature: N/A
Special Fire Fighting Procedures: NONE - THIS IS AN EXTINGUISHING AGENT		
Unusual Fire and Explosion Hazards: None		

**SECTION 4 - PHYSICAL HAZARDS**

Stability: Unstable <input type="checkbox"/> Stable <input checked="" type="checkbox"/>	Conditions to Avoid: N/A
Incompatibility (Materials to Avoid):	Reactive Metals, ClF <sub>3</sub> , electrically energized equipment, any material reactive with water.
Hazardous Decomposition Products:	Not established, acrid fumes.
Hazardous Polymerization: May Occur <input type="checkbox"/> Will Not Occur <input checked="" type="checkbox"/>	Conditions to Avoid: N/A

504 p/n 303903 o/pM WV-4H Ventless Hoplite Cooktop



**SECTION 5 - HEALTH HAZARDS**

ANSULEX Low pH (continued)

Threshold Limit Value:	None Established		
Routes of Entry: Eye Contact:	Irritant		
Skin Contact:	Irritant		
Inhalation:	Not an expected route of entry. Can be irritating to mucous membranes.		
Ingestion:	Irritating to mucous membranes. Acute Oral LD <sub>50</sub> (Sprague-Dawley rats) 825.5mg/kg.		
Signs and Symptoms:	Acute Exposure: Material irritates skin, eyes, and mucous membranes. Chronic Exposure: None known.		
Medical Conditions Generally Aggravated by Exposure:	None known.		
Chemical Listed as Carcinogen or Potential:	National Toxicology Program: Yes <input type="checkbox"/> No <input checked="" type="checkbox"/>	I.A.R.C Monographs: Yes <input type="checkbox"/> No <input checked="" type="checkbox"/>	OSHA Yes <input type="checkbox"/> No <input checked="" type="checkbox"/>

**SECTION 6 - EMERGENCY AND FIRST AID PROCEDURES**

Eye Contact:	Flush and irrigate with water for 15 minutes while holding eyelids open. If irritation persists, seek medical attention.
Skin Contact:	Wash thoroughly with soap and water. If irritation persists, seek medical attention.
Inhalation:	Fresh air if symptoms occur. If irritation persists, seek medical attention.
Ingestion:	Dilute by drinking large quantities of water.

**SECTION 7 - SPECIAL PROTECTION INFORMATION**

Respiratory Protection (Specify Type):	N/A		
Ventilation:	Local Exhaust: N/A	Mechanical (General):	N/A
Protective Gloves:	Rubber gloves for spill/leak	Eye Protection:	Chemical goggles recommended during spill/leak procedures.
Other Protective Clothing or Equipment:	Eye wash and safety showers are good safety practice.		

**SECTION 8 - SPECIAL PRECAUTIONS AND SPILL/LEAK PROCEDURES**

Precautions to be taken in Handling and Storage:	Store in original container. Keep tightly closed. Keep separate from acid.
Other Precautions:	See incompatibility information in Section 4.
Steps to be taken in Case Material is Released or Spilled:	Stop leaks. Contain spills. Remove as much as possible. Place in closed container for proper disposal Wash spill area with large amounts of water to remove traces and neutralize.
Waste Disposal Methods:	Dispose of in compliance with local, state and federal regulations.

**HAZARDOUS MATERIAL IDENTIFICATION SYSTEM**

<i>HAZARD INDEX</i>	
4 SEVERE HAZARD	0 HEALTH
3 SERIOUS HAZARD	
2 MODERATE HAZARD	0 FLAMMABILITY
1 SLIGHT HAZARD	
0 MINIMAL HAZARD	0 REACTIVITY

N/A = Not Applicable      NDA = No Data Available      N/E = Not Established  
ANSUL and ANSULEX are registered trademarks.

Internet Address: <http://www.ansul.com>

ANSUL INCORPORATED, ONE STANTON STREET, MARINETTE, WI 54143-2542

Form No. F-90160-6

©1999 Ansul Incorporated

504 p/n 303903 opM WV-4H Ventless Hooplate Cooktop

## TROUBLESHOOTING SUGGESTIONS

SYMPTOM	POSSIBLE CAUSE	SUGGESTED ACTION
Ventilator blower won't run	Circuit breaker tripped	Check / reset circuit breaker
Ventilator blower won't run — buzzer sounding	Ansul® fire suppression system tripped	Contact Authorized Ansul® Distributor for repairs
Ventilator blower runs momentarily, shuts down.	Clogged filter , or filter out of position	Observe indicator lights, service filter(s) as required
	Damaged internal components	Contact your Authorized Wells Service Agent for repairs
<i>CHECK FILTERS</i> light on	Filter or grease baffle out of position	Reinstall filters / baffle
<i>REPLACE PREFILTER</i> light on.	Pre-filter clogged, but still operational	Replace pre-filter at first opportunity
<i>REPLACE FILTER PACK</i> light on	Filter pack clogged, but still operational	Replace filter pack at first opportunity
<i>SERVICE REQUIRED</i> light on	Prer-filter or filter pack clogged	Replace pre-filter first. If indicator stays lit, replace filter pack
Cooktop won't heat	Ventilator not operational	See above
	Temperature control not set	Set control to desired temp
	Damaged internal components	Contact your Authorized Wells Service Agent for repairs
One or more cooktop sections not hot enough	Temperature control not set	Set control to desired temp
	204V unit run on 208V	Contact your Authorized Wells Service Agent for conversion
Roll warmers won't heat (ventilator operational)	Damaged internal components	Contact your Authorized Wells Service Agent for repairs
	Damaged internal components	Contact your Authorized Wells Service Agent for repairs
Warmer drawer not hot enough	Temperature control not set	Set control to desired temp
Product in warmer drawer too dry or wet	Humidity control not set	Set for desired humidity

**NOTE:** There are no user serviceable components in the appliance.

- A. In all cases of damage or component malfunction, contact your Authorized Wells Service Agency for repairs.
- B. For service of the fire suppression system, contact an Authorized Ansul® Distributor.

## PARTS & SERVICE

### DESCRIPTION

### SERVICE PART NO.

PRE-FILTER	22618
PRE-FILTER CAGE	22683
FILTER PACK (HEPA + CHARCOAL)	22619
GREASE BAFFLE	22684
LEG ASSEMBLY	22646
GREASE CUP	22626
DRIP TRAY, 8" (Spiral Hotplate)	21705
ELEMENT SUPPORT (Spiral Hotplate)	500039
SCRAPER, CLEANING (Ceramic Hotplate)	22445
CLEANING CREME, CERAMIC HOTPLATE	501124
DRAWER PAN, REPLACEMENT RACK, HUMITROL	21488 20624
WELLS BULLETIN (ANSUL® PARTS LIST)	303331
<p><b>NOTE:</b> Ansul® Manual 418087-05 and Wells Bulletin 303331 are intended for use by authorized <b>Ansul®</b> service personnel only. Ansul® Manual 418087-05 must be obtained through your authorized Ansul® distributor.</p>	

**IMPORTANT: Use only factory authorized service parts and replacement filters.**

For factory authorized service, or to order factory authorized replacement parts, contact your Wells authorized service agency, or call:

**Wells Bloomfield, LLC**  
 2 Erik Circle  
 P. O. Box 280  
 Verdi, NV 89439

Service Parts Dept.  
 phone: (775) 689-5707  
 fax: (775) 689-5976

Service Parts Department can supply you with the name and telephone number of the **WELLS AUTHORIZED SERVICE AGENCY** nearest you.

### CUSTOMER SERVICE DATA

please have this information available if calling for service

RESTAURANT _____	LOCATION _____
INSTALLATION DATE _____	TECHNICIAN _____
SERVICE COMPANY _____	
ADDRESS _____	STATE _____ ZIP _____
TELEPHONE NUMBER (____) _____ - _____	
EQUIPMENT MODEL NO. _____	
EQUIPMENT SERIAL NO. _____	
VOLTAGE: (check one) <input type="checkbox"/> 208 <input type="checkbox"/> 240	



Wells Bloomfield proudly supports CFESA  
Commercial Food Equipment Service Association

**SERVICE TRAINING - QUALITY SERVICE**



**CUSTOMER SATISFACTION**



**WELLS BLOOMFIELD, LLC**  
2 ERIK CIRCLE, P. O. Box 280 Verdi, NV 89439  
telephone: 775-689-5703  
fax: 775-689-5976  
[www.wellsbloomfield.com](http://www.wellsbloomfield.com)

PRINTED IN UNITED STATES OF AMERICA