

Honeywell

OPERATION MANUAL

DSP COLOR CAMERA

GC-715N24

GC-715P24



* "BMB™" is the Trade Mark of Honeywell, CCTV CoE.



READ AND RETAIN THIS OPERATION MANUAL

MEMO

Honeywell

Control Products Business Unit

18F, Kukje Center Building, 191,
Hangangro-2ga, Yongsan-gu,
Seoul 140-702, Korea
Tel : 82-2-799-6109
Fax : 82-2-749-6119

E-mail : cctv@honeywell.com
<http://www.honeywell.co.kr/cctv>
Printed in Korea
G-110821

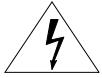

CAUTION
RISK OF ELECTRIC SHOCK
DO NOT OPEN



CAUTION : TO REDUCE THE RISK OF ELECTRIC SHOCK.
DO NOT REMOVE COVER(OR BACK).
NO USER SERVICEABLE PARTS INSIDE
REFER SERVICING TO QUALIFIED SERVICE PRERSONNEL

Explanation of Graphical Symbols.

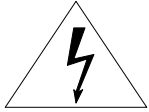

This symbol is intended to alert the user to the presence of uninsulated “dangerous voltage” within the product’s enclosure that may be of sufficient magnitude to constitute a risk of electric shock to persons.



This symbol is intended to alert the user to the presence of important operating and maintenance(Servicing) Instructions in the literature accompanying the appliance.

MEMO

CAUTIONS FOR SAFE OPERATION !

- Changes or modifications not approved by manufacturer could void the user's authority to operate the equipment.
- To prevent fire or shock hazard, do not expose this camera to rain or moisture.
- To prevent electric shocks and other hazards, do not use different from the specified power source.
- Do not install too hot or cold places, recommended operation temperature is -10℃ ~ 50℃
- Do not expose lens directly to the sun. CCD may be damaged.
- Do not place the camera to heavy shocks or vibrations.
- Do not place or install the camera on an unstable place, stand, tripod, bracket or table.
That may cause serious injury to people or damage to appliance.
- Do not attempt to service or repair of yourself. Please contact all servicing to qualified service personnel
- In case of installing too close to Monitor, variation of monitor brightness cause any hunting of camera in low light mode.

1

Cautions for safe operation	-----	1
About GC-715N/P24	-----	3
Name and function of each section	-----	4
Installation	-----	5
Adjustment and operation	-----	8
Specifications	-----	23
Accessory		

- C mount adapter
- IRIS JACK for AUTO IRIS LENS

2

GC-715N/P24

Outlines

Honeywell's GC-715N/P24 is a high sensitivity CCD color camera with high sensitivity function of the field integration technique.

Features

- ☞ 1/3" IT Super HAD CCD (NTSC: 410,000 / PAL: 470,000)
- ☞ Outstanding BLC implementation with Honeywell's BMB(Black Mask BLC) function. (3 levels adjustable)
- ☞ CS/C lens mount.
- ☞ Excellent signal-to-noise ratio of more than 50dB.
- ☞ High Sensitivity : Minimum illumination of 0.001lx (F1.2, 30IRE, SENS On X 128)
- ☞ 2-WAY Auto Iris : Video iris or DC iris lens can be used.
- ☞ External synchronization with LINE LOCK.
- ☞ Auto White Balance : Auto white balance realizes true color reproduction within various light sources. (2,800 °K~8,000 °K)
- ☞ Control : Flickerless, Back light compensation , AGC , Manual shutter control, Maximum Sensitivity select, Auto white Balance/ Indoor/Outdoor/Fluorescent light/ BMB Level

3

Name and function of each section

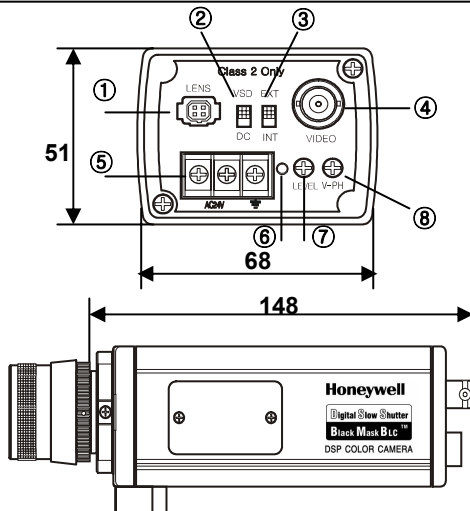

- ① AUTO IRIS lens connector
- ② AUTO IRIS lens select switch
- ③ Sync. select switch
- ④ Video output connector
- ⑤ Power input connector
- ⑥ Power lamp
- ⑦ DC IRIS level adjustment (when using DC IRIS lens)
- ⑧ V- PHASE adjustment (when using LINE LOCK)

[unit : mm]

4

Installation

Mounting a Lens

1. Remove the protective cap in front of the camera.
 2. Confirm the mount ring whether it is for C or CS. * Caution1
 3. Attach the lens to the lens mount ring.
 4. If the lens has an Auto Iris mechanism, connect the iris cable to the Lens connector (EE/VSD S/W must be set to VSD on the side of the camera)
 - A. In the case of having no iris amplifier : Set the slide switch to DC (Down side)
 - B. In the case of having iris amplifier : Set the slide switch VSD (Upper side)
 - C. Set the S/W on the side of the camera to DC or VSD, too.
- ☞ If using lens that has iris amplifier, "LEVEL" and "ALC" volume of lens must be adjust carefully. It may cause any hunting.
 - ☞ When connecting Auto iris lens, be sure to use the connector to be recommended by manufacturer. (E4-191, Chuo Musen, Japan)

* Caution 1 : This appliance is set to CS mount default.

If you want to use C mount lens, fix a C adapter ring additionally packed in the box.

5

When Auto-Iris Lens is used...

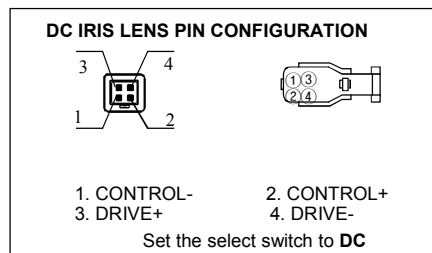
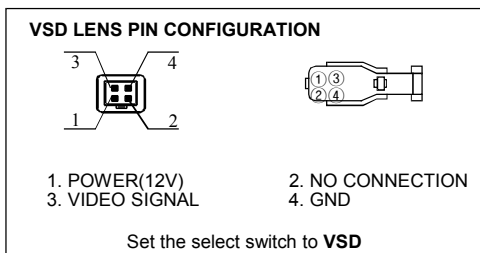

* For the best condition, read lens manual carefully .

* After connecting Auto iris-lens you may need to set flange back focus.

Connection of AC power supply

- ☞ Must be checked the power source from the external power supply before power on.
- ☞ Recommended power source capacity :
AC 24V, more than 500mA

6

Flange back focus adjustment

1. In case of fixed focus lens
 - a. Loosen the locking ring and set the focus ring of lens to infinity (∞) .
 - b. Tune the mount ring to get a clear picture(distance from camera to object is more than 23m) and fasten the locking ring.
2. In case of zoom lens
 - a. Loosen the locking ring and set the lens to the maximum telephoto position. Then turn the focus ring to focus.
 - ☞ in the case of Auto iris lens, shoot a comparatively dark object or reduce the ambient light so that the Iris is fully open.
 - b. Set the lens to its maximum wide angle position, and set the focus.
 - c. Repeat step a and b, until the difference between focusing position a and b is smallest.
 - D. When the best focusing point is found, fasten the locking ring.

Adjustment and operations

Configuration

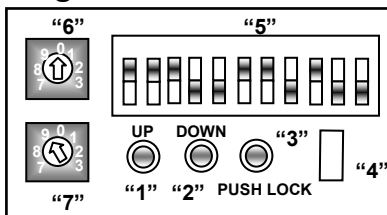

Fig 1. SIDE view

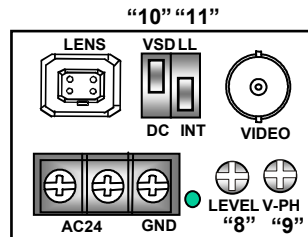

Fig 2. REAR view

The function of each part

1. Button "1" & "2"

In line lock mode, zero crossing point can be adjusted by pressing these buttons.

In MWB mode, manual white balance can be adjusted by pressing these buttons.

2. Button "3"

In One push lock mode, white balance can be aligned by pressing this button.

When this button is released, white balance is locked.

3. Connector "4"

Used for EEPROM data setting in factory.

4. DIP switch "5"

Shipment setting consists of "AGC High", "AWC", "SENS".

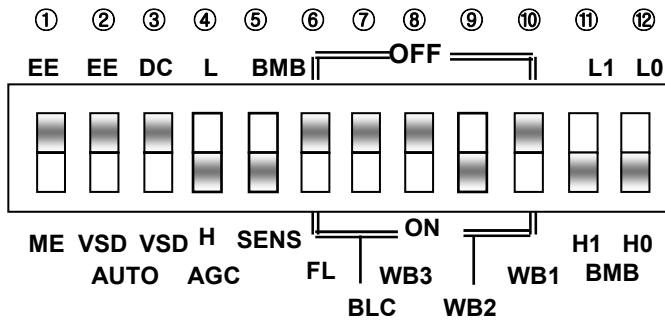

Fig 3. Button detail

① "EE/ME" Mode (Electronic Exposure / Manual Exposure)

If using electronic exposure or a lens with automatic iris, the "EE/ME" switch has to be set to "EE". If using a manual lens, you can use the rotary switch to adjust the shutter speed of the camera manually.

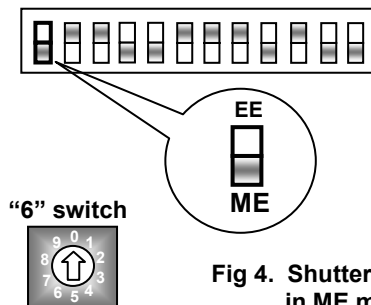
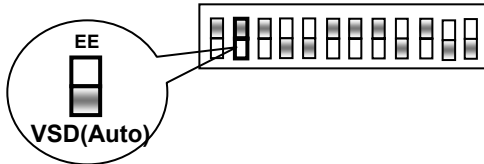

Fig 4. Shutter Speed in ME mode

Mode	715N24	715P24	Remark
0	1/60 sec	1/50 sec	default
1	1/120 sec	1/100 sec	
2	1/250 sec		
3	1/500 sec		
4	1/1,000 sec		
5	1/2,000 sec		
6	1/4,000 sec		
7	1/5,000 sec		
8	1/10,000 sec		
9	1/100,000 sec		

② “EE/VSD” Mode (Lens type selection)



If using a manual lens, the “EE/VSD” switch has to be set to “EE”. If using a lens with automatic iris, the “EE/VSD” switch has to be set to “VSD”

11

③ “DC/VSD(AUTO)” Mode (Auto Iris Lens type selection)

Auto Iris Lens are DC Type or VSD Type.

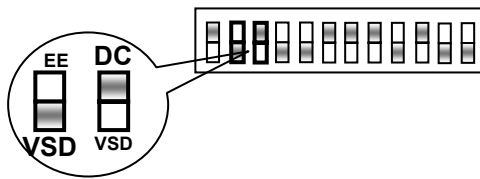

- ◆ in case of using DC iris lens.
 - “EE/VSD” switch on side to “VSD”, “EE/VSD” switch on rear to “DC”.
 - Slowly turn “8” LEVEL on Rear until the monitor picture appears to be not too bright or too dark.

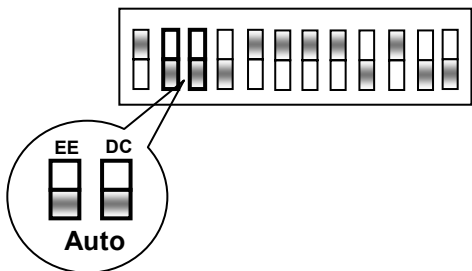

- ◆ in case of using AUTO iris lens
 - Set “EE/VSD” switch on Side to “VSD”.
 - Set “EE/VSD” switch on Rear to “VSD”.

12

④ “AGC” Mode (Automatic Gain Control)

Select the AGC mode to high (gain 32dB) or low (gain 26dB).

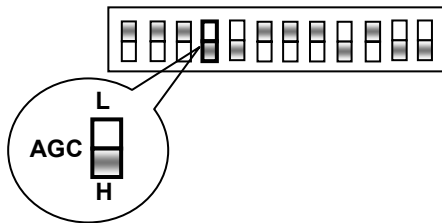

When this switch is to “high”, the maximum AGC is set to 32 dB, and sensitivity increases automatically when illumination becomes dark . In AGC high mode , the integration time of the memory can be further decreased than AGC low mode (26dB) , and moving object is displayed more natural. But the noise of video signal is further increased .

⑤ “BMB/SENS” Mode

What is BMB?

- BMB is the trade mark of Honeywell, that means BLACK MASK BLC. (BMB™)
- It is to improve the weak points of Electronic Iris & BLC.
- Mask the excessive light by 3 making level and minimize the loss of outlines of Objects due to strong light.

◆ BMB(Black Mask BLC) Mode

It can be adjustable to 3 levels according to surrounding condition.
(Factory default : 3Level)

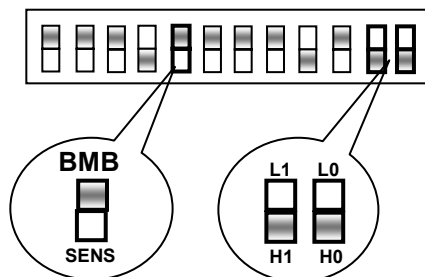

LEVEL	H1	H0	Remark
OFF	X	X	
1	X	O	GRAY
2	O	X	DARK GRAY
3	O	O	BLACK

< BMB level adjustment >

As higher BMB level, making level is darker.
and around the masked area become lighter.

- ☞ It is impossible to use BMB and SENS functions simultaneously !!!
 To use BMB or SENS, select "BMB/SENS" switch one of two,
 To use neither BMB nor SENS, select "BMB" and level "H1,H0" to OFF.
 or select "SENS" and set the Rotary switch "7" to "0".

◆ SENS(Sensitivity Up mode) Mode

If the sensitivity ON mode is selected and in low light conditions, the camera sensitivity is increased by getting picture from the memory.

Maximum sensitivity is selectable out of 9 steps . (Refer to Fig5)

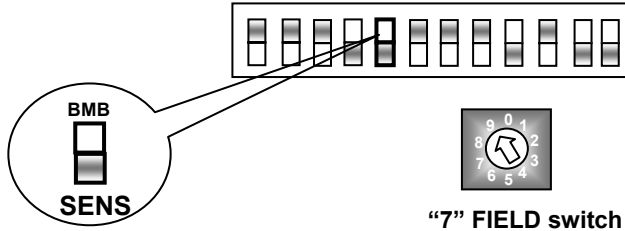

Mode	Setting	Fields/sec	Remark
0	OFF	60	
1	X2	30	
2	X4	15	
3	X6	10	
4	X8	7.5	
5	X10	6	
6	X16	3.8	
7	X32	1.9	
8	X64	0.9	
9	X128	0.5	Default

Fig 5. Maximum sensitivity setting table

- ☞ In the sensitivity ON mode , sensitivity is automatically controlled within maximum sensitivity setting value.

⚠ Cautions in SENS mode

1. In high sensitivity mode , moving object is displayed as if it is flowing, because the integration time of the CCD becomes long.
Further, movement is unnatural due to intermittent read-out.
2. In high sensitivity mode, white blemishes may be remarkable.
3. In high sensitivity mode, noises as well as video information are increased.
When an ambient temperature becomes high, noises are further increased.
This is not due to failure.
4. In PAL version, flickers may be remarkable for some objects in high sensitivity mode, because the electronic sensitivity amplification is employed.
5. It doesn't work in FL mode.

⑥ "FL" Mode (Flickerless)

Use for removing the flicker of picture.

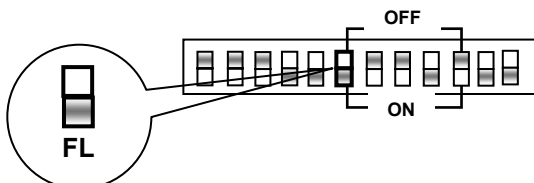

- In case of NTSC(60Hz) :
Fix Shutter Speed to 1/100 sec
- In case of PAL (50Hz) :
Fix Shutter Speed to 1/120 sec

⑦ "BLC" Mode (Backlight Compensation)

Too bright light or sunlight behind the object makes the object appear dark .

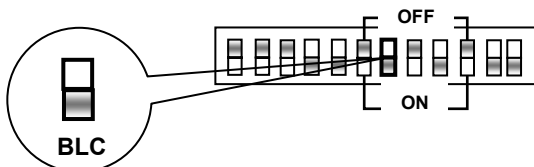

- In BLC ON state, you can distinguish the objects in front of the bright area without darkness.
- Do not use the BLC function if using the Low-light mode with manual Iris Lens.

⑧ ⑨ ⑩ “WB” Mode (White Balance Mode)

WB Mode can be selected by WB1,WB2,WB3, UP,DOWN, PUSH LOCK switch.

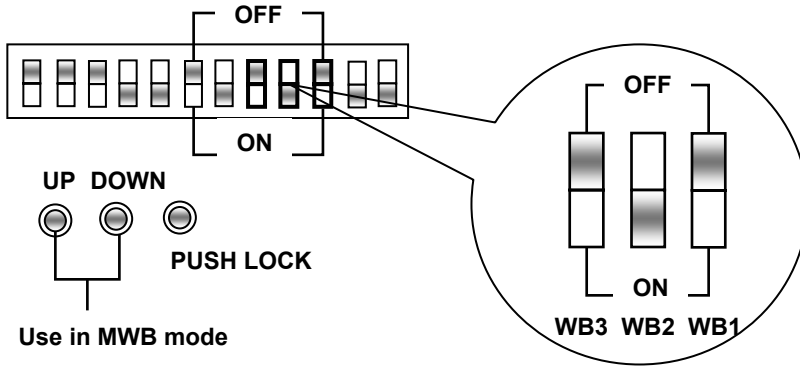

WB3	WB2	WB1	AWB Mode
OFF	OFF	OFF	ATW Mode
OFF	ON	OFF	AWC Mode (Default)
ON	ON	OFF	One Push Lock
ON	OFF	OFF	MWB Mode
OFF	OFF	ON	Indoor Fixed Mode (3200 °K)
ON	OFF	ON	Fluorescent Fixed Mode (4200 °K)
OFF	ON	ON	User Fixed Mode (4700 °K)
ON	ON	ON	Outdoor Fixed Mode (6300 °K)

Fig 6. WB Mode Table

◆ “ATW” Mode

Auto Trace White Balance Mode.

This mode is the feedback system that automatically aligns the white balance.

(Operating Range 2,800 °K~ 8,000 °K)

◆ **“AWC” Mode**

Auto White Balance Control Mode. This mode performs more faster action than ATW mode without operating range. AWC operation is also performed in one push lock mode. while the button “3” on the side view is pressed, AWC action started and then the button is released, WB operation is locked to fit the present shooting scene.

◆ **One Push Lock Mode**

In One push lock mode, white balance can be aligned by pressing “3” button. When this button is released, white balance is locked.

◆ **“MWB” Mode**

Manual White Balance Mode.

This mode is used for manual adjustment of white balance.

This mode can be adjusted by pressing buttons.(Button“1”, “2” on SIDE VIEW)

6. “9” V-PHASE (In the line lock mode, Adjustment V-Phase)

When you are using the line lock, the LL/INT switch has to be set to “LL” mode.

a. Line lock zero cross adjustment

; Zero cross point can be adjusted by pressing “1”(UP) and “2”(DOWN) buttons of the camera

- ☞ Zero crossing point of shipment state can be initialized after pressing the UP button (Button“1”) during about 10 seconds .

b. Line lock V-phase adjustment

; If more than two cameras are used in one switching system, phase difference in AC power line can be occurred.

It is needed to adjust this phase difference for each camera.

- ☞ If the cameras are connected to different AC lines, you can use the line lock adjustment potentiometer of the camera (adjustment of V-PH)

SPECIFICATIONS

	GC-715N24	GC-715P24
Imaging device	1/3" CCD(total 410,000pixels)	1/3" CCD (total 470,000pixels)
Effective pixel	768H * 494V(380,000pixels)	752H * 582V(440,000pixels)
Scanning system	525 Lines 2:1 Interlace	625 Lines 2:1 Interlace
Sync system	Internal/ Line lock	Internal/ Line lock
Scanning frequency	15.734KHz(H), 59.94Hz(V)	15.625KHz(H), 50.0Hz(V)
H Resolution	480 TV Lines	480 TV Lines
Video out	VBS 1.0Vp-p / BNC	VBS 1.0Vp-p / BNC
S/N Ratio	more than 50dB	more than 50dB
Min. illumination	less than 0.2lx(F1.2, 30IRE, AGC ON) SENS ON 0.001lx (X128 fields)	less than 0.2lx(F1.2, 30IRE, AGC ON) SENS ON 0.001lx (X128 fields)
BLC	BLC ON/OFF, BMB ON(3Steps)/OFF	BLC ON/OFF, BMB ON(3Steps)/OFF
White Balance	AWB(2,800 °K ~8,000 °K)	AWB(2,800 °K ~8,000 °K)
Elec. Shutter	1/60s ~1/100,000s	1/50s ~1/100,000s
AGC	High / Low	High / Low
Lens Mount	C/CS Mount	C/CS Mount
ALC	EE, VSD, DC	EE, VSD, DC
Power Source	AC24V±10%,500mA	AC24V±10%,500mA
Operating Temp.	-10℃ ~ +50℃	-10℃ ~ +50℃
Storage Temp.	-20℃ ~ +70℃	-20℃ ~ +70℃
Weight	436g	436g
Dimensions	68(W) * 51(H) * 148(D)	68(W) * 51(H) * 148(D)