

LifeFitness

ARCTIC SILVER 93T-XXXX-09 TREADMILL

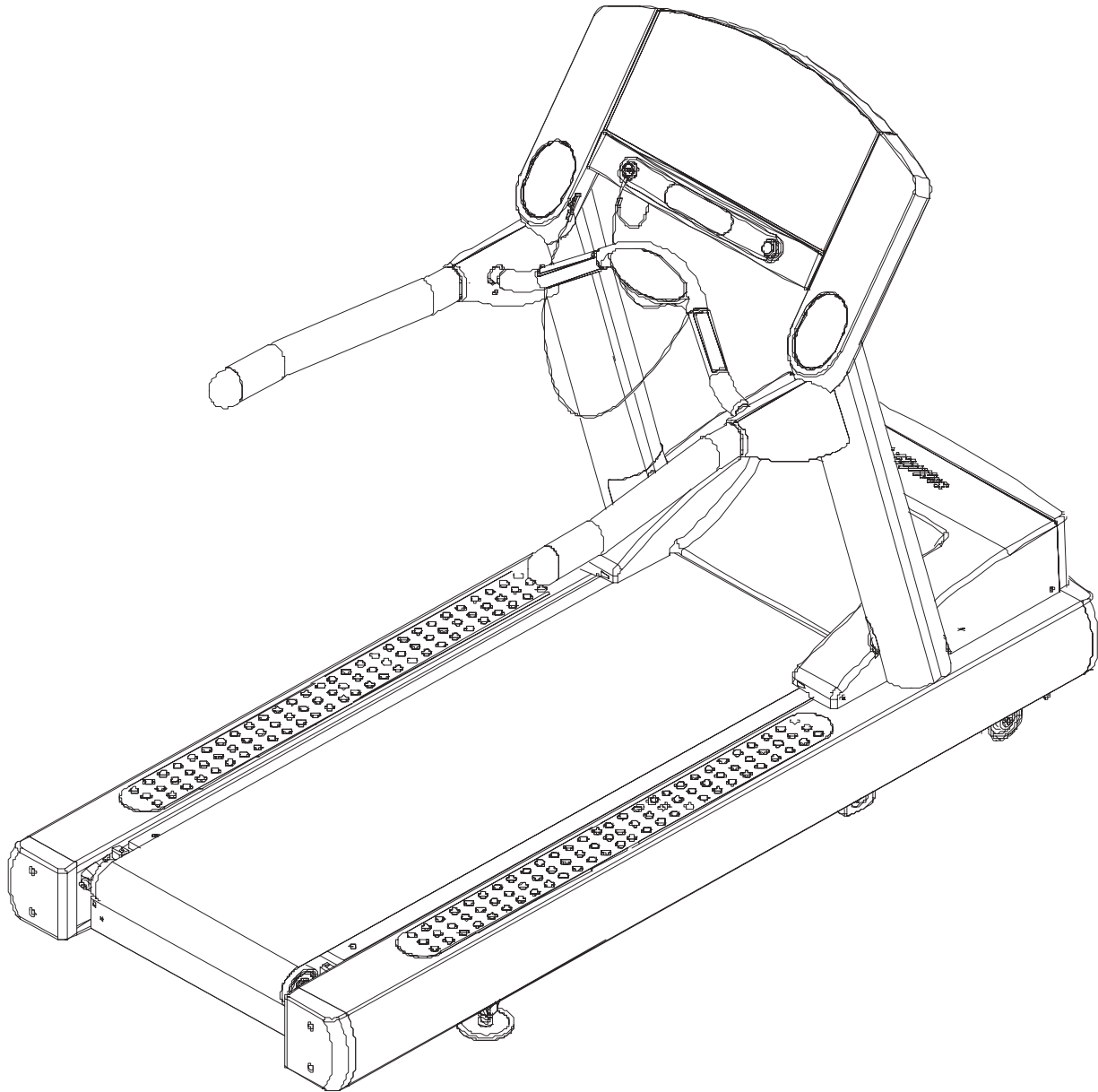

Customer Support Services
PARTS MANUAL

revised 12 Mar 2008

Miscellaneous	3
Console, Overlay Assembly, and Overlay	4
Console Components	5
Uprights and Handrails	6
Ergo Bar with Heart Rate Assembly	7
Rear End Caps, and Cup Holders	8
Motor Cover, Front Cover, End Caps, and Tinsel	9
On-off Switch, Access Plate, and Grommets	10
Belt, Deck and Rear Roller	11
Lift Frame, Lift Motor, and IEC Receptacle	12
Idler Arm Assembly	13
Leg Leveler Assembly	14
Front Roller Assembly	15
Drive Motor Assembly	16
DSP Controller Assembly	17
Line Cords and Line Cord Options	18
Block Diagrams	19

Description	Part No.
OPERATION MANUAL - (ENG)	M051-00K58-A330
OPERATION MANUAL - (F/S/P)	M051-00K58-A331
OPERATION MANUAL - (G/D/I)	M051-00K58-A332
OPERATION MANUAL - (JAP)	M051-00K58-A333
SERVICE MANUAL	M051-00K58-A256
ACCESS PANEL ASSY. CONSISTS OF:	AK58-00329-0000
1) 120" POWER EXT. CABLE	AK32-00078-0001
2) CONNECTOR MTG. PLATE	0K58-01392-0000
3) F-TYPE ADP CONNECTOR	0017-00021-2810
4) F-TYPE PANEL CONNECTOR	0017-00021-2846
COAX CABLE	AK32-00020-0002
ARCTIC SILVER TOUCH UP PAINT FOR FRAME:	
SPRAY CAN	0017-00008-0204
.5 OZ BOTTLE W/APPLICATOR	0017-00008-0205
.33 OZ PEN	0017-00008-0206
FOR INK TRANSFER DECALS:	
.6 OZ BOTTLE	0017-00008-0210
.6 OZ PEN	0017-00008-0211
HARDWARE BAG	AK58-00226-0000

NOTE: When this model is ordered with an attachable LCD TV, it becomes a model 93TER-XXXX-09. See Entertainment parts list LCD-0XXX-02 for the part numbers and descriptions for the attachable LCD TV, remote, and hardware for this product. Model 93T-XXXX-09 comes with both Lifepulse sensors and telemetry for reading heart rate.

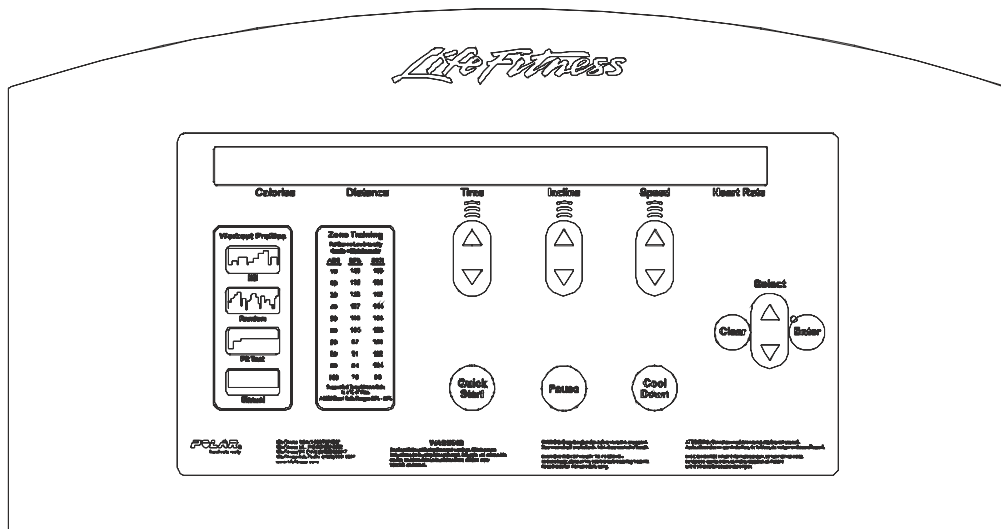

Language	Part No.		
	Console	Overlay/Bezel Assembly	Overlay
ENG/ENG	AK58-00481-0001	AK58-00526-0001	OK58-01432-0001
ENG+MET	AK58-00481-0002	AK58-00526-0001	OK58-01432-0001
GERMAN	AK58-00481-0003	AK58-00526-0003	OK58-01432-0003
SPANISH	AK58-00481-0004	AK58-00526-0004	OK58-01432-0004
JAPANESE	AK58-00481-0006	AK58-00526-0006	OK58-01445-0006
FRENCH	AK58-00481-0007	AK58-00526-0007	OK58-01432-0007
ITALIAN	AK58-00481-0008	AK58-00526-0008	OK58-01432-0008
DUTCH	AK58-00481-0009	AK58-00526-0009	OK58-01432-0009
PORUGUESE	AK58-00481-0010	AK58-00526-0010	OK58-01432-0010

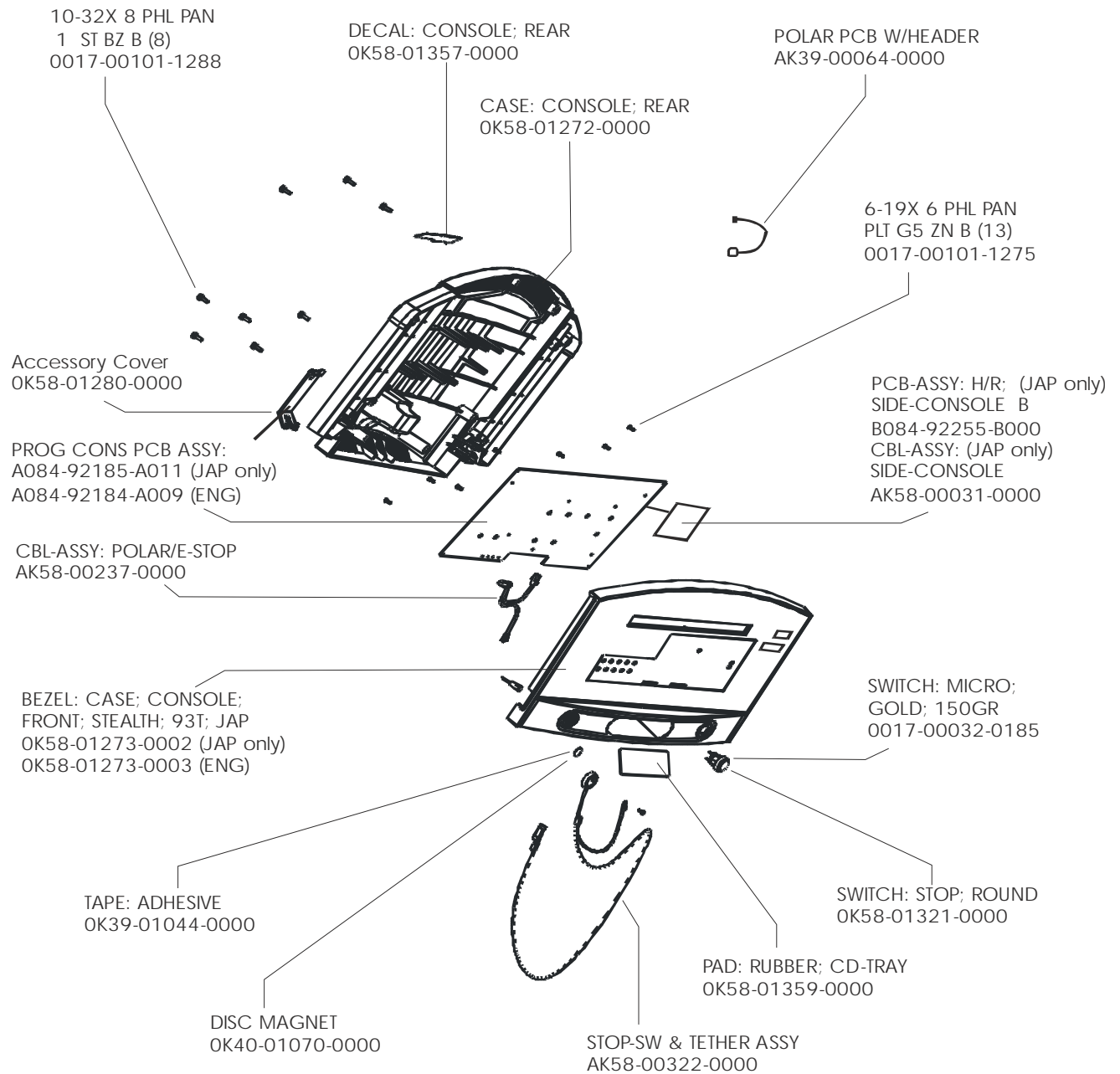

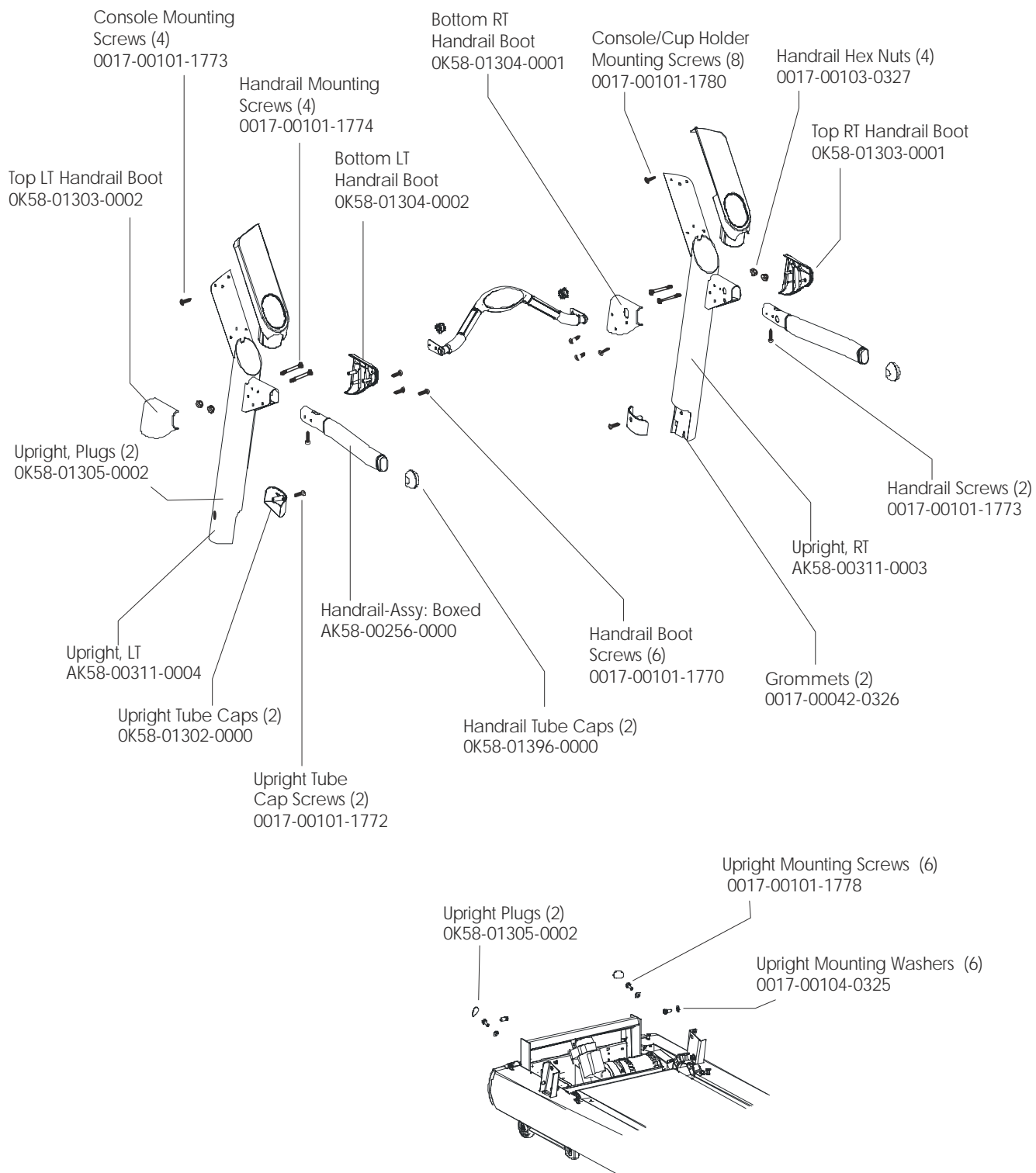

Ergo Bar with Heart Rate Assembly
AK60-00147-0000

ERGO-BAR OVERMOLD
ASSY: PURCH. D
AK58-00376-0000

8-16X18 PHL PAN
PLT ST BO B (2)
0017-00101-0824

VMI WSH 8 171-,375-052
FL-D ST BZ B
0017-00104-0411

6-18 x 16 PHL PAN
HLS ST ZN B
0017-00101-1277

COVER: I/R LENS SENSOR
OK58-01103-0000

Heart Rate Sensor Kit
KIT: SERV; MFG; ELECTRODES; LARGE
GK20-00002-0005

GASKET: ERGOBAR
OK58-01347-0000

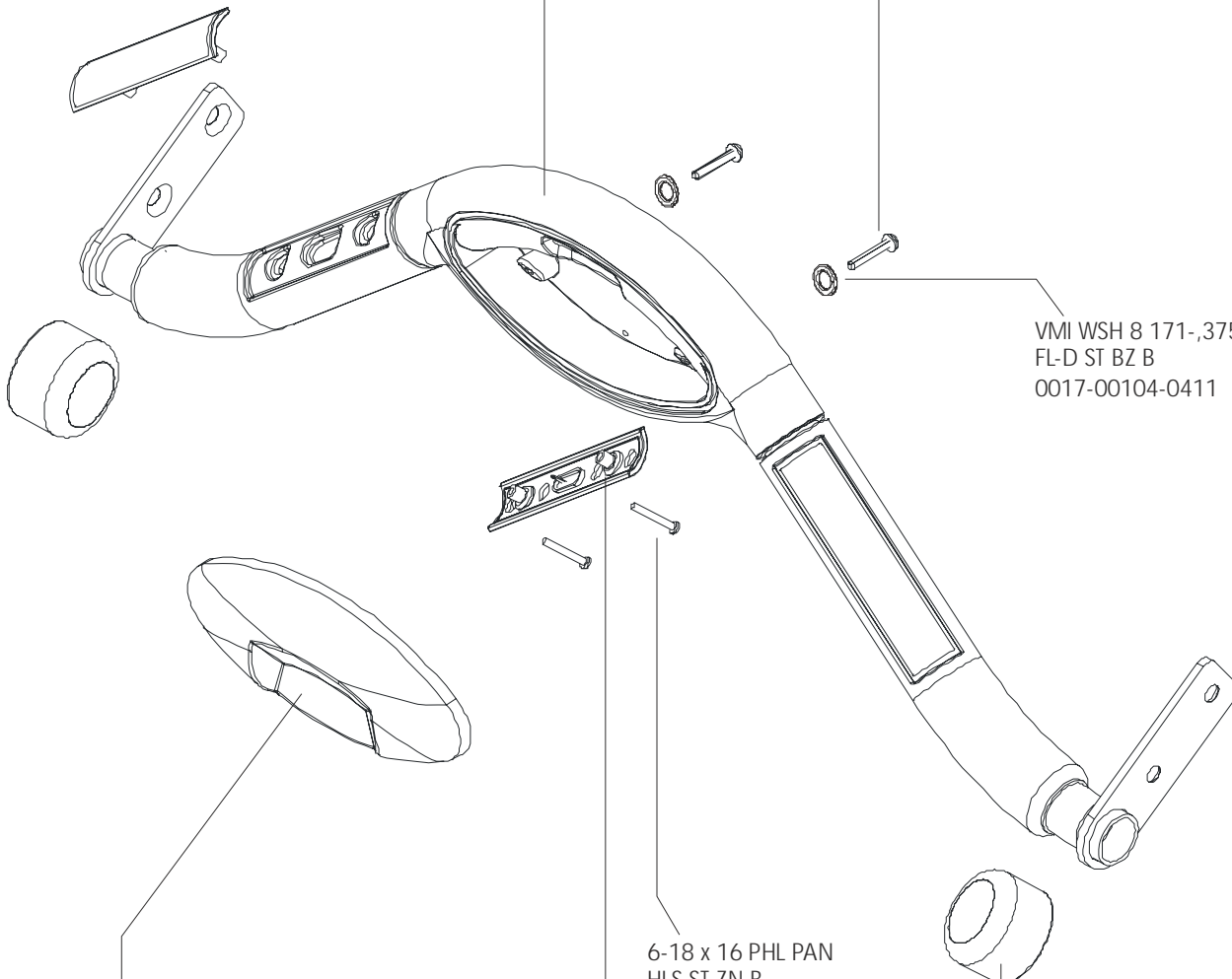

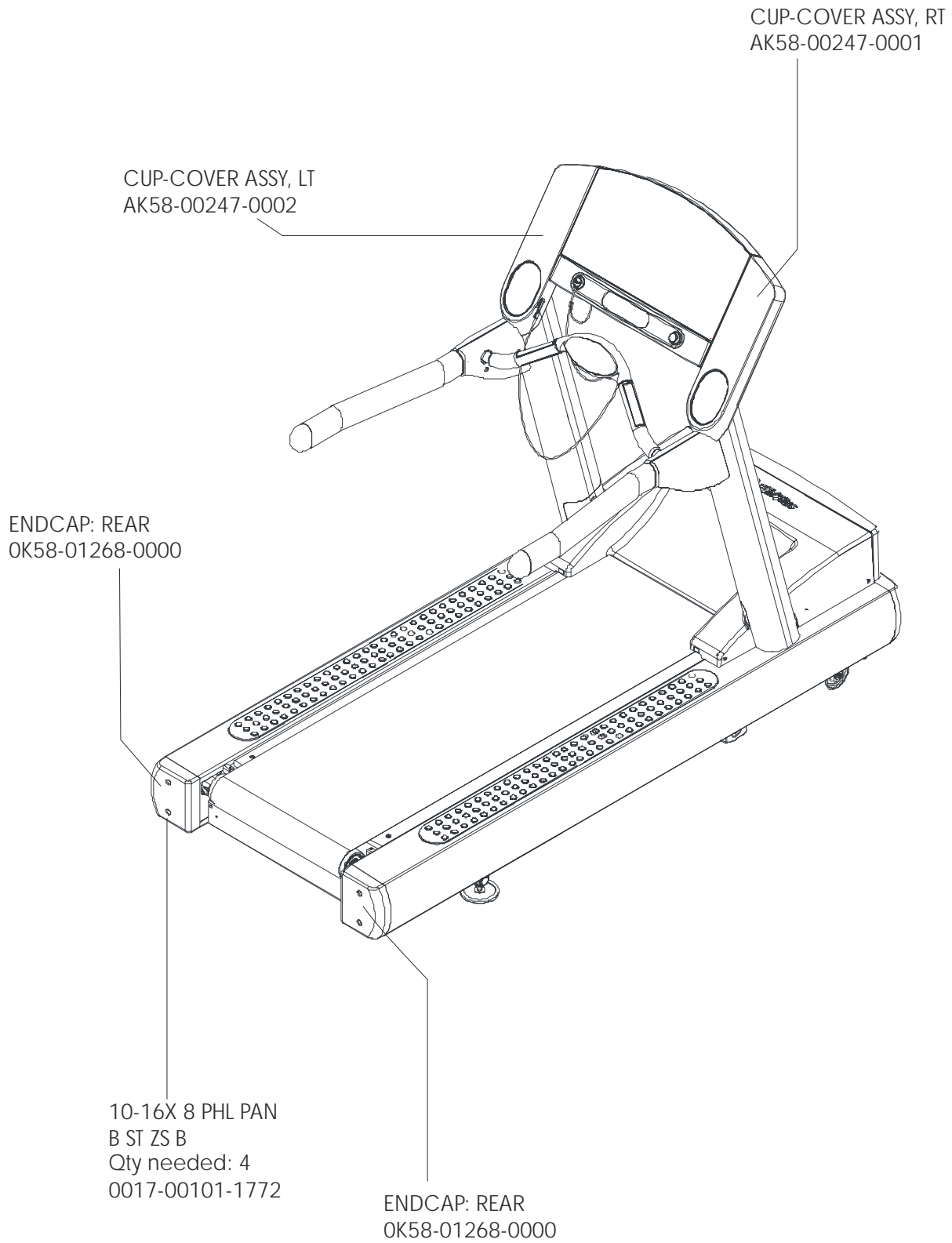

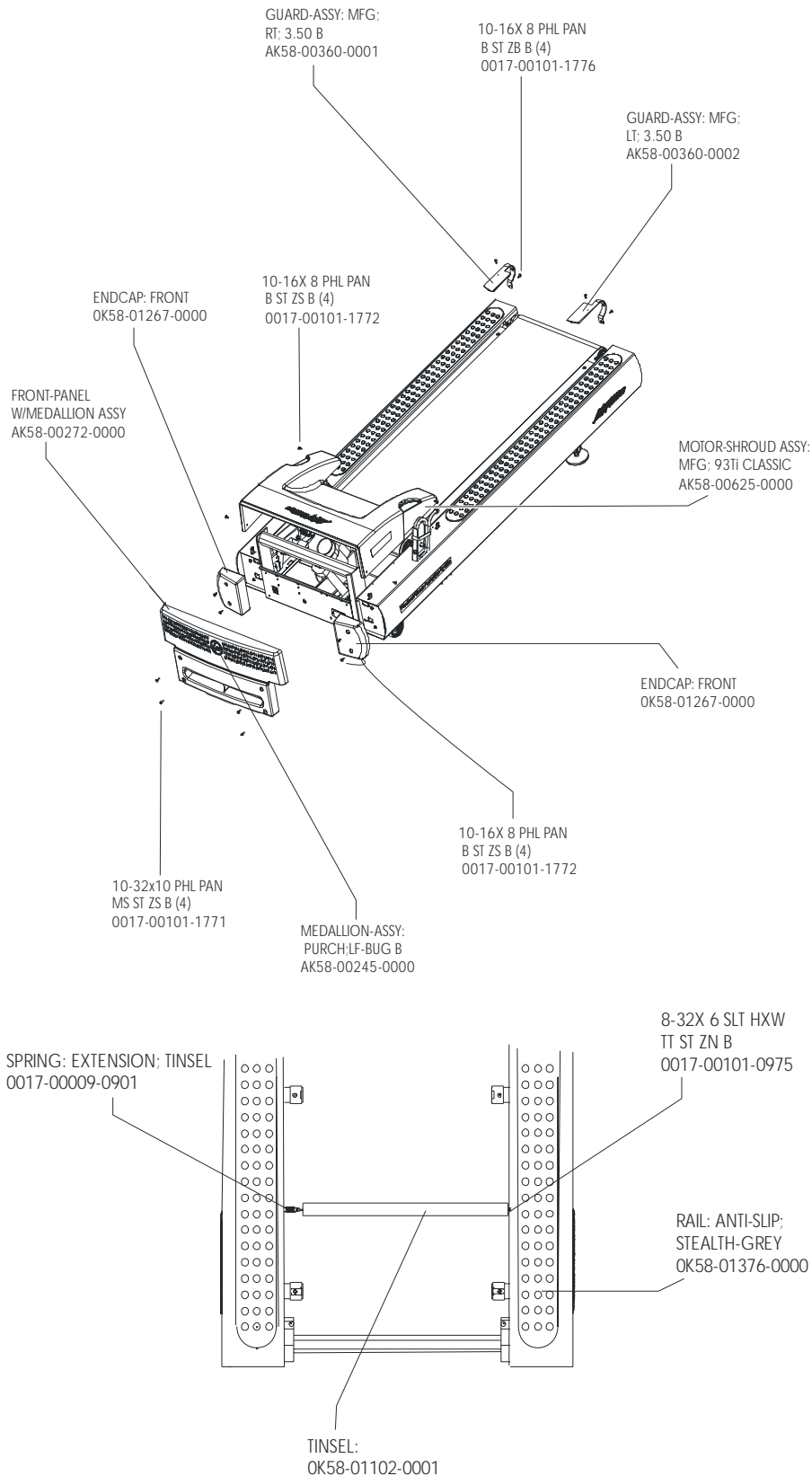

GROMMET: PLASTI; .
130/.005 S/C# 13-B (4)
0017-00042-0326

Note: the ink transfer decal can
be retouched but it cannot be
replaced in the field.
(see service bulletin GN05032101N)

DECAL: FRAME; LF-LOGO
OK60-01193-0000

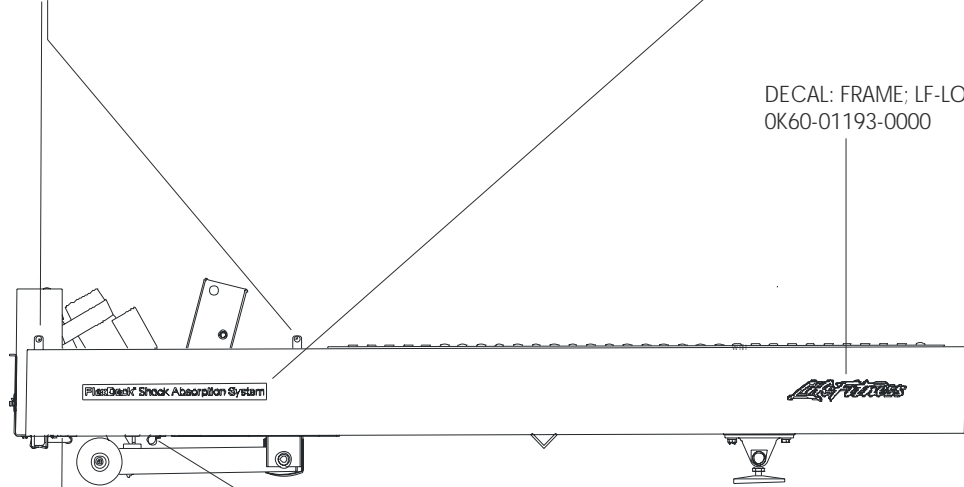

CLIP: WIRE; PUSH-
MTG; 3/4"; S/C#80-B
0017-00042-0840

CLAMP: WIRE; 5/8"
0017-00042-1072

GROMMET: PLASTI; .
130/.005 S/C# 13-B (2)
0017-00042-0326

FRONT VIEW

BACK VIEW

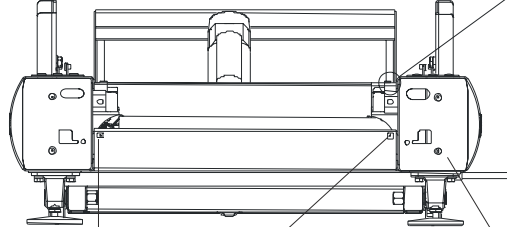
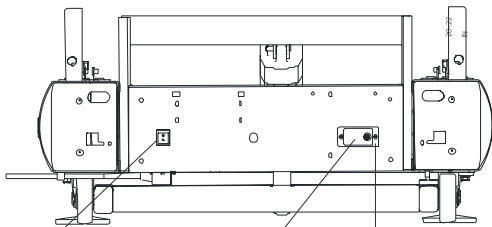

SWITCH: ROCKER;
22A DPST
0017-00032-0198

ACCESS-PLATE ASSY
AK58-00329-0000

8-32X 6 PHL PAN
TT ST PH B (2)
0017-00101-0162

GROMMETS:
NYLON; SCREW (2)
0017-00042-1147

GROMMETS: PLASTI; .
130/.005 S/C# 13-B
(8: 4 front, 4 rear)
0017-00042-0326

ARCTIC SILVER 93T
Belt, Deck and Rear Roller

93T-XXXX-09
S/N TTL100000 and up

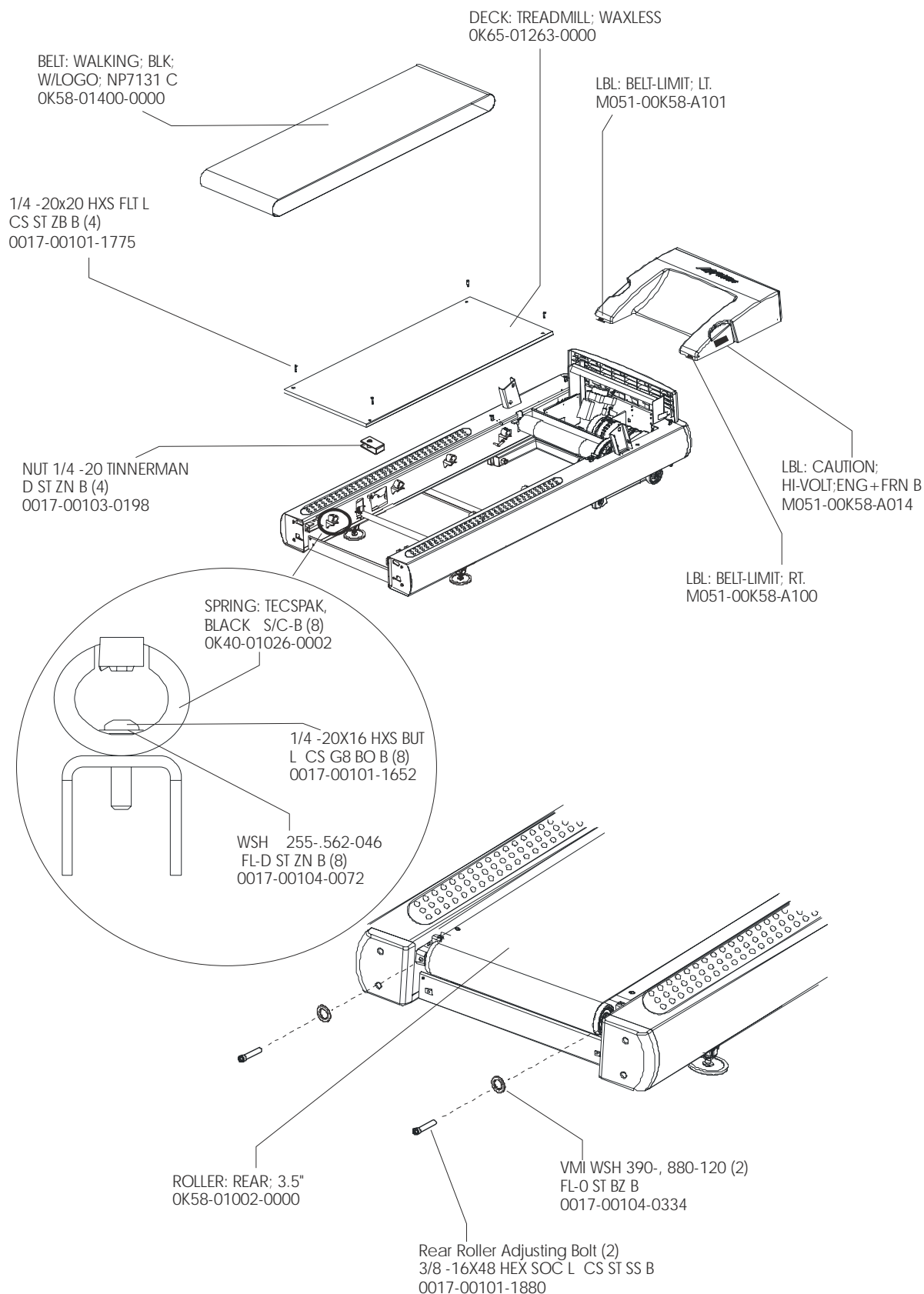

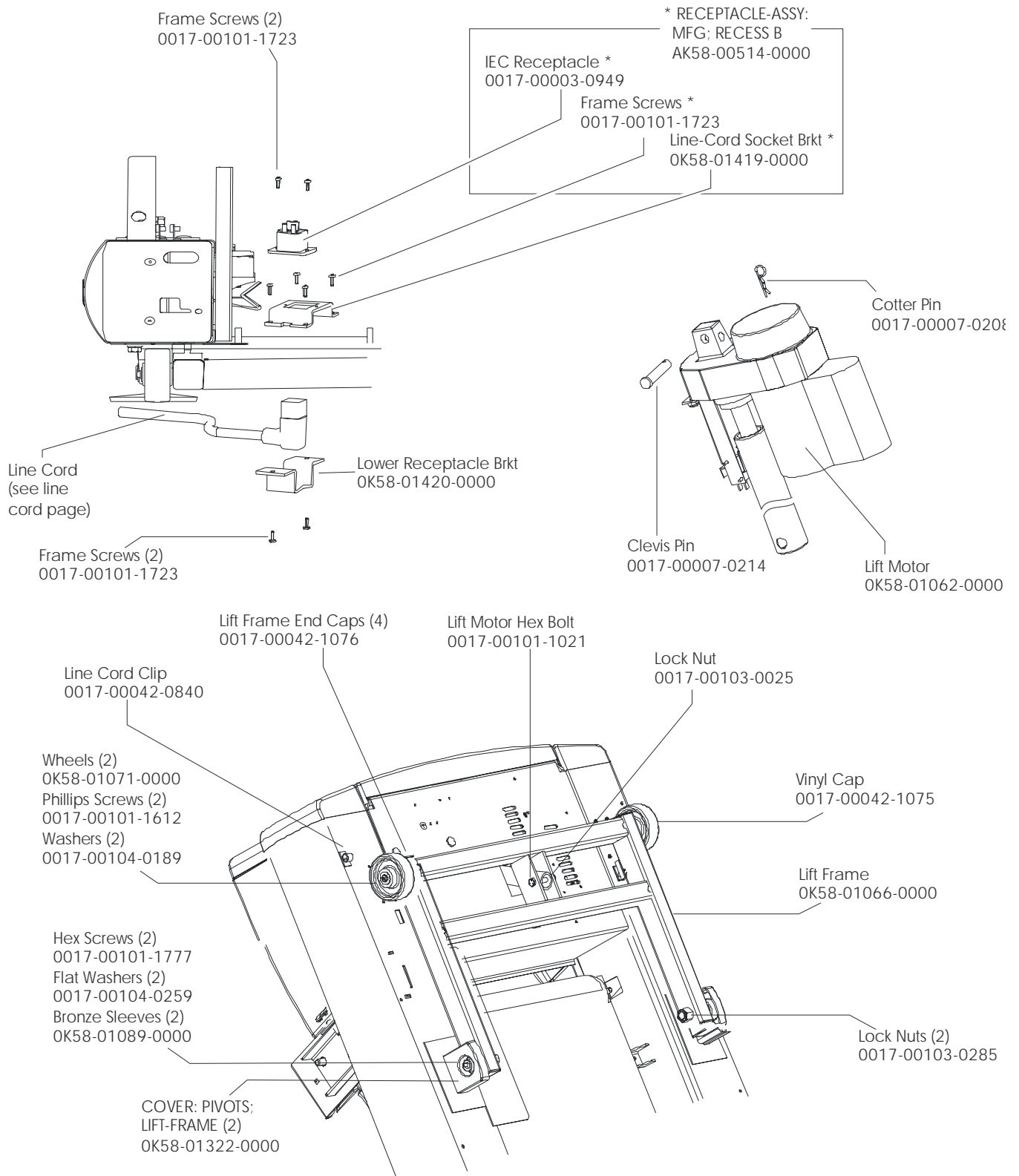

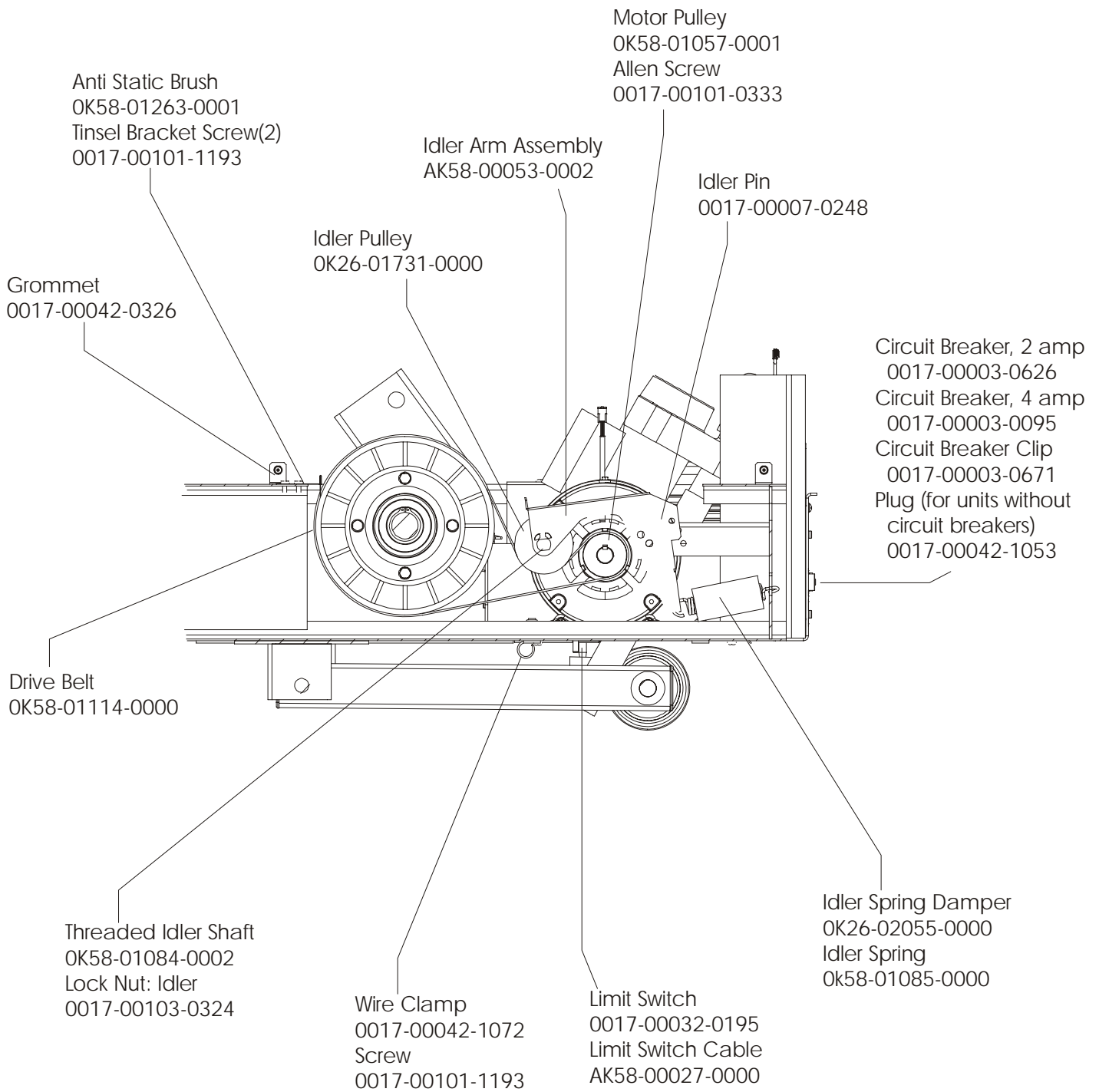

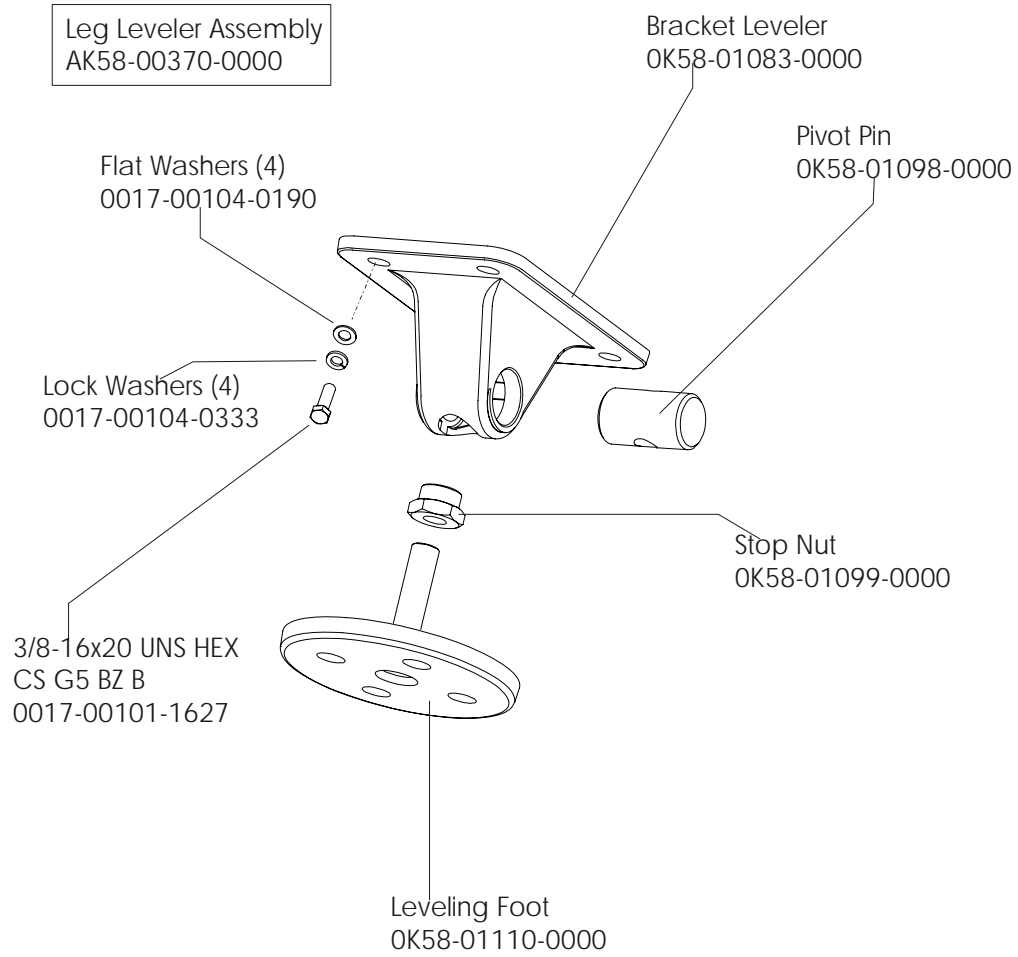

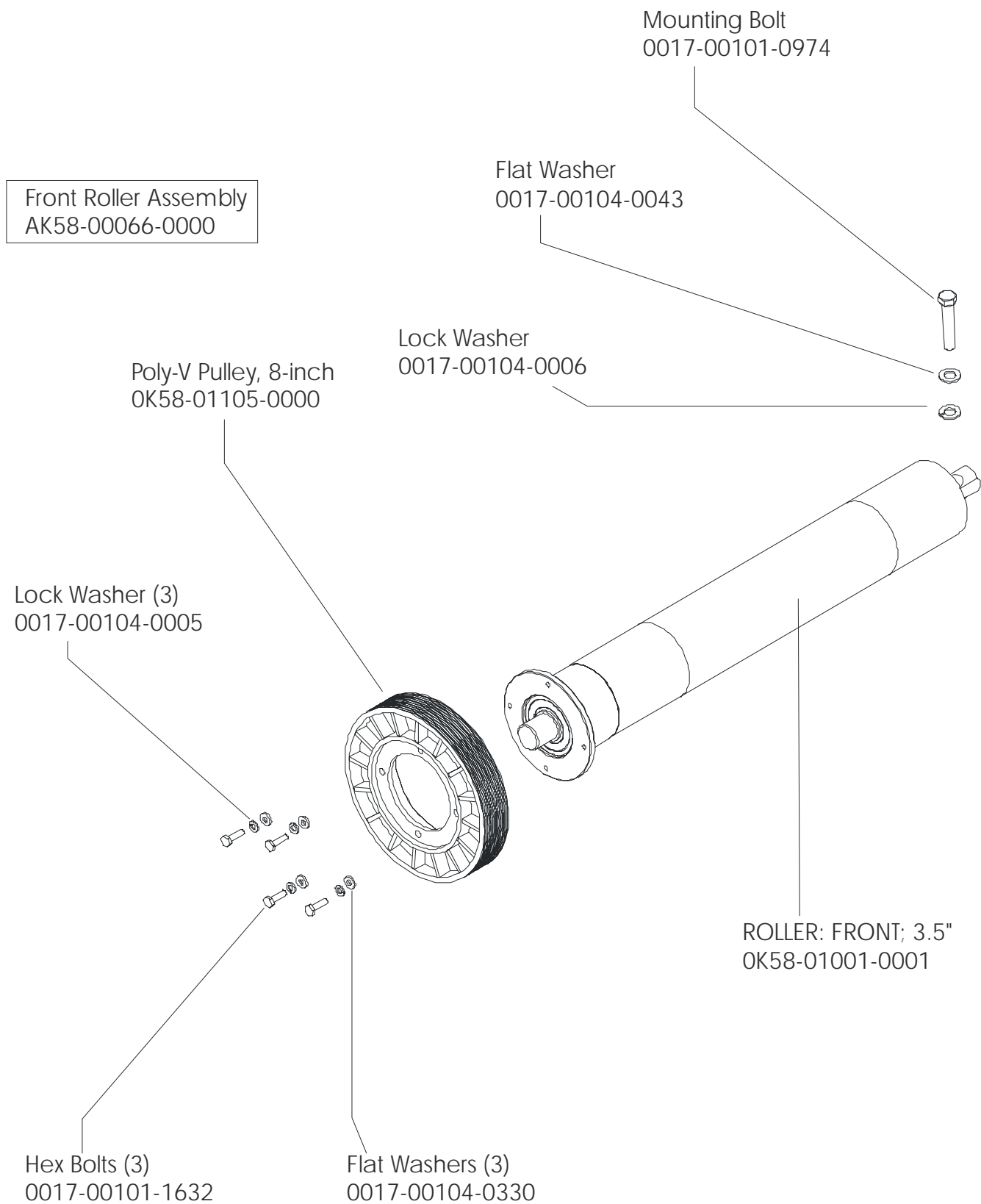

ARCTIC SILVER 93T
Drive Motor Assembly

93T-XXXX-09
S/N TTL100000 and up

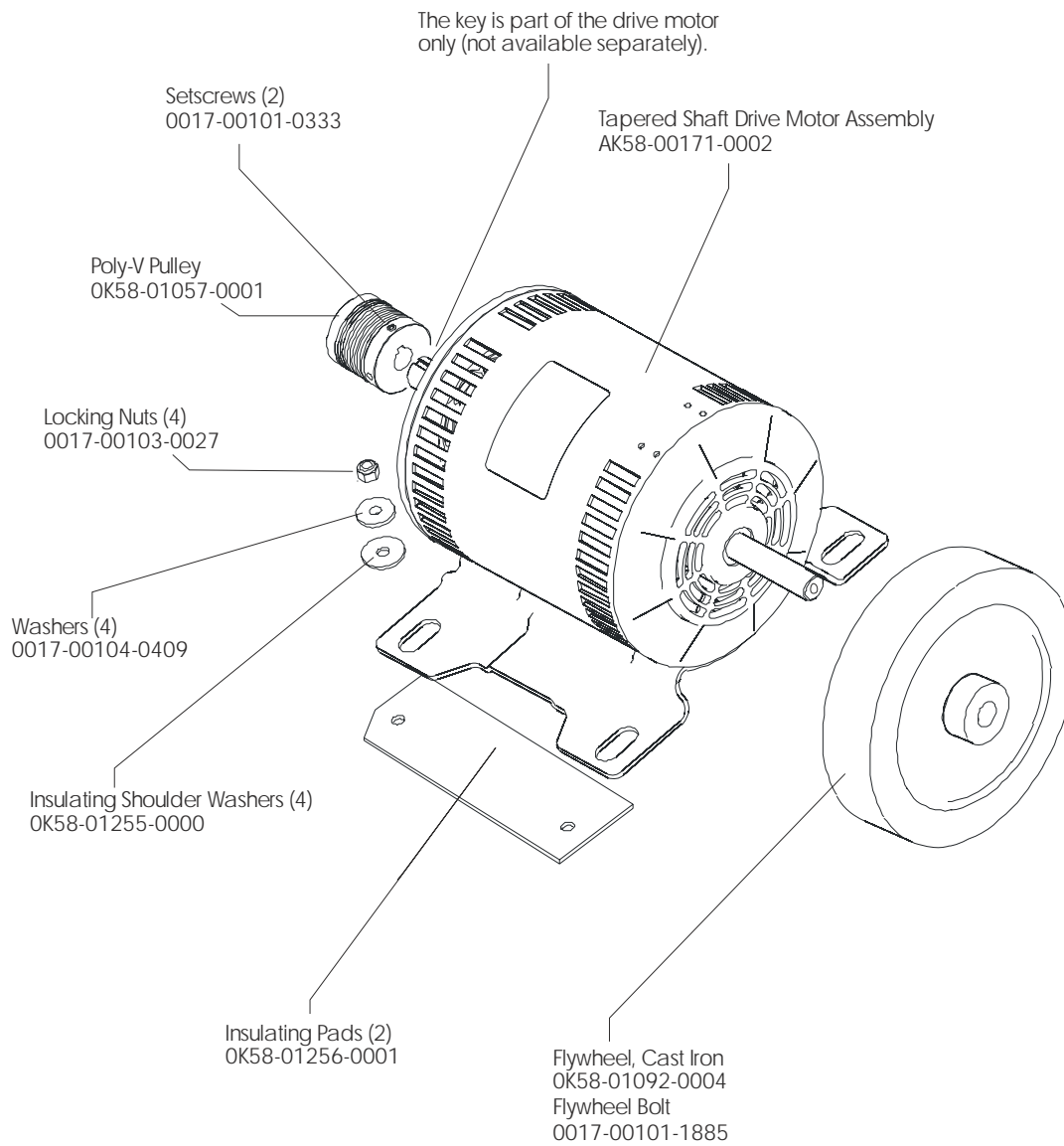

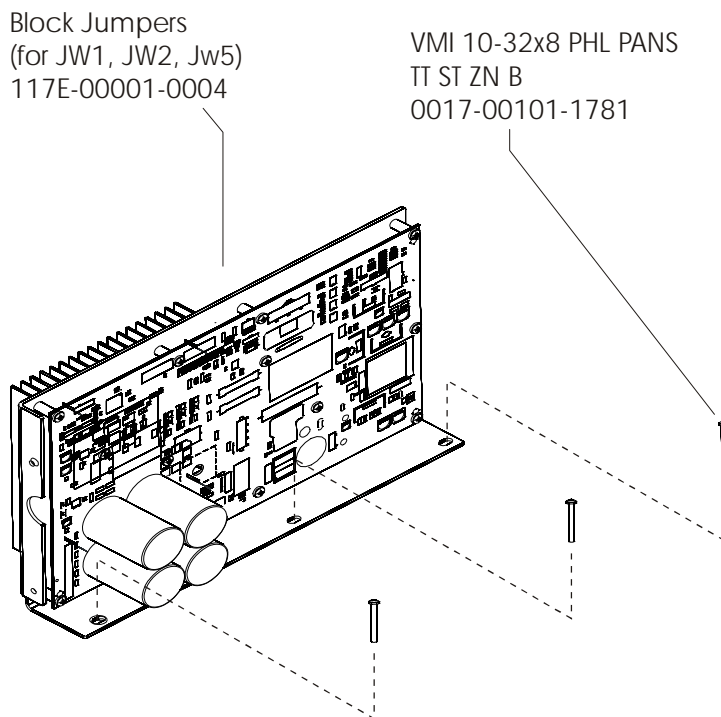

DSP Controller Assembly		
Part Description	Voltage	Part No.
KIT: SERV; MFG; DSP CONTROLLER 100-120; LED	100-120	GK58-00002-0118
KIT: SERV; MFG; DSP CONTROLLER 200-240; LED	200-240	GK58-00002-0120

Standard Line Cords		
Model #	Model Description	Part No.
93T-0100-09	93T ENG/ENG 120/60 DOM	0017-00003-0974 LINE-CORD: R/A; 96"; W/RECP S/C-C
93T-0300-09	93T FRN/MET 120/60 DOM	
93T-0400-09	93T SPN/MET 120/60 DOM	
93T-0800-09	93T POR/MET 120/60 DOM	
93T-0103-09	93T ENG+MET 220/60 DOM	0017-00003-0781 LINE-CORD: R/A; 220V; USA D
93T-0105-09	93T ENG+MET 100/50 DOM	
93T-0106-09	93T ENG+MET 200/50 DOM	
93T-0705-09	93T JAP/MET 100/50 DOM	
93T-0706-09	93T JAP/MET 200/50 DOM	
93T-0101-09	93T ENG+MET 230/50 CON	0017-00003-0696 LINE-CORD: R/A; CEE7; 103" 10A 250V D
93T-0201-09	93T GER/MET 230/50 CON	
93T-0301-09	93T FRN/MET 230/50 CON	
93T-0401-09	93T SPN/MET 230/50 CON	
93T-0501-09	93T ITL/MET 230/50 CON	
93T-0601-09	93T DUT/MET 230/50 CON	
93T-0801-09	93T POR/MET 230/50 CON	
93T-1601-09	93T ENG/TUR 230/50 CON	
93T-0102-09	93T ENG+MET 240/50 UK	0017-00003-0890 LINE-CORD: U.K; R/A
93T-0109-09	93T ENG+MET 230/50 UK	
93T-0104-09	93T ENG+MET 240V+ AUS	0017-00003-0996 LINE-CORD: IEC; AUSTRALIAN; 230/50 C

Optional Line Cords		
Description	Length (feet)	Part No.
LINE-CORD: 120V; 20A;	12'	0017-00003-0947
LINE-CORD: R/A 120V	8'	0017-00003-0915
LINE-CORD: R/A; NEMA 5-20 144"	12'	0017-00003-0980
LINE-CORD: R/A; W/PLUG 220/60	7.5'	0017-00003-0981
LINE-CORD: 220V; 15A;	12'	0017-00003-0948

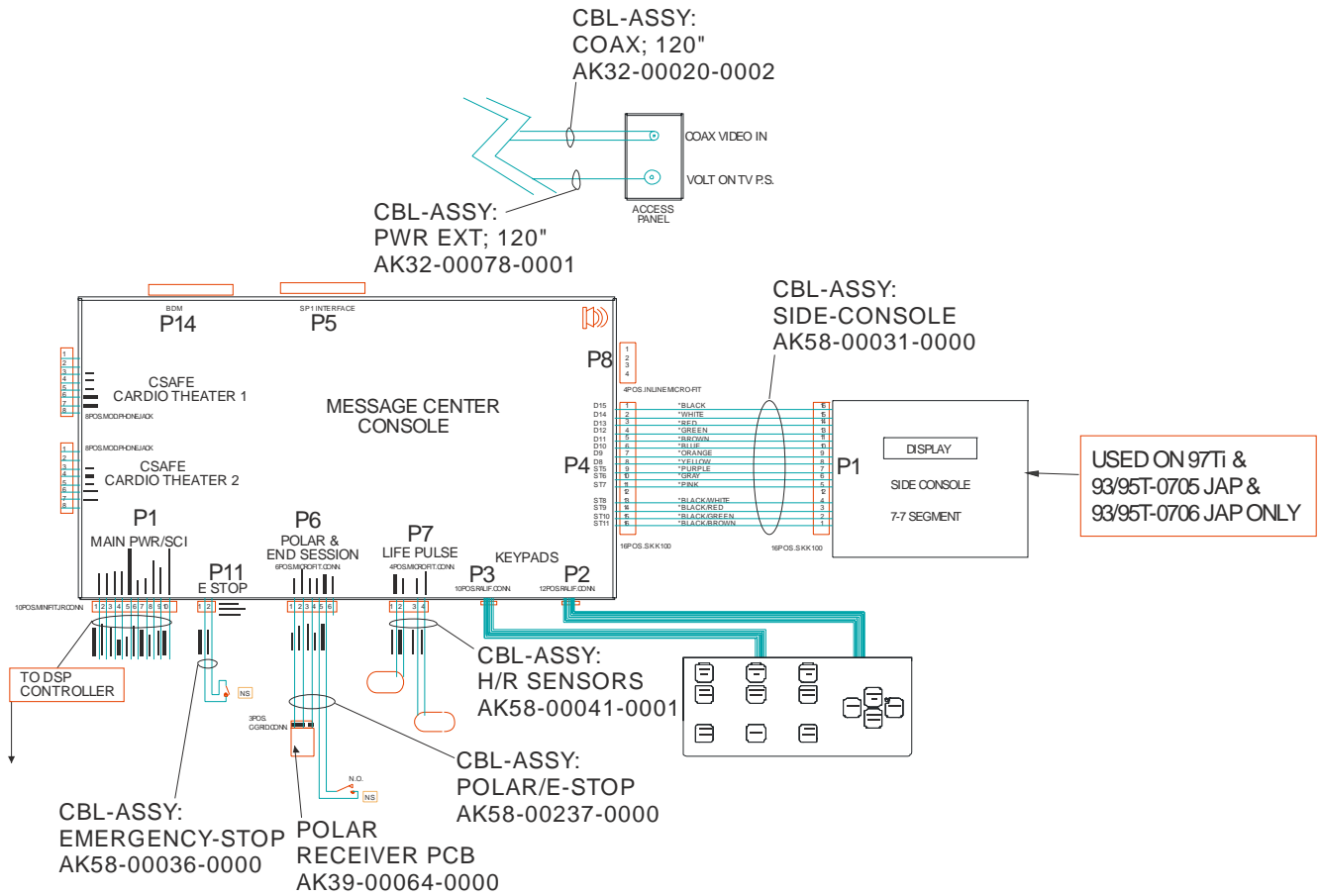

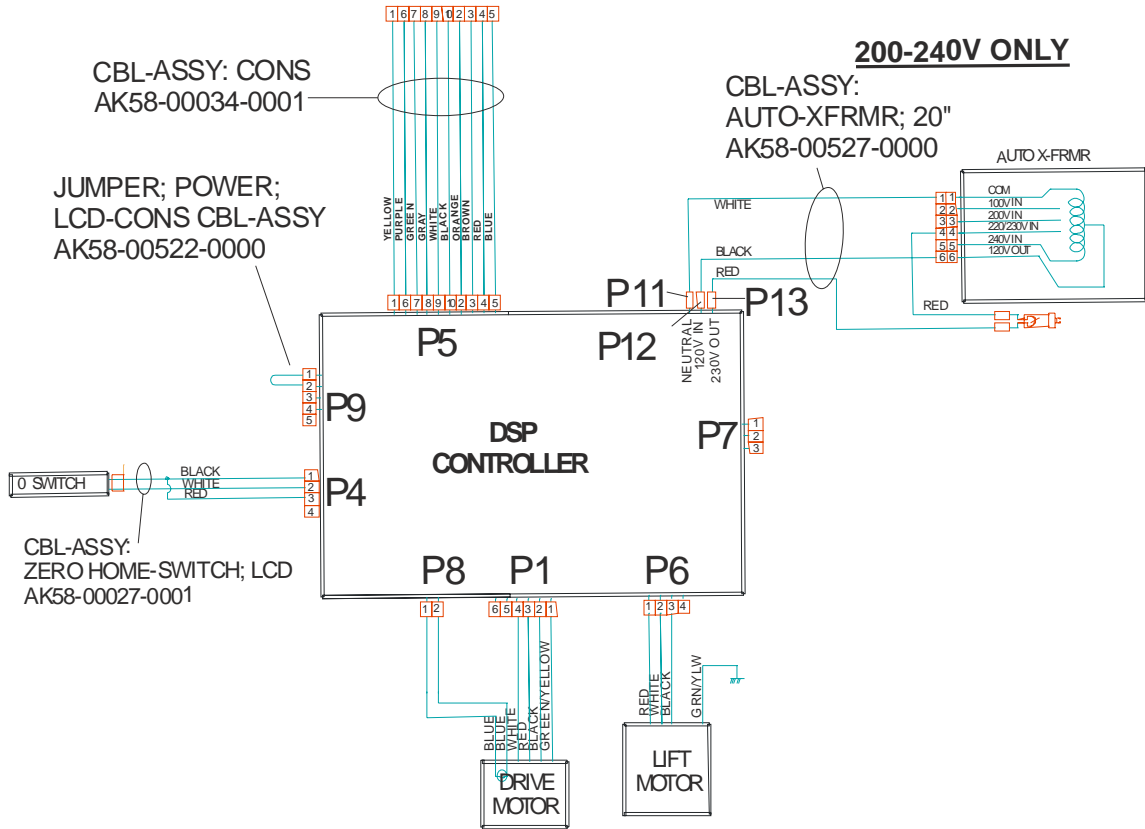

120V DOMESTIC

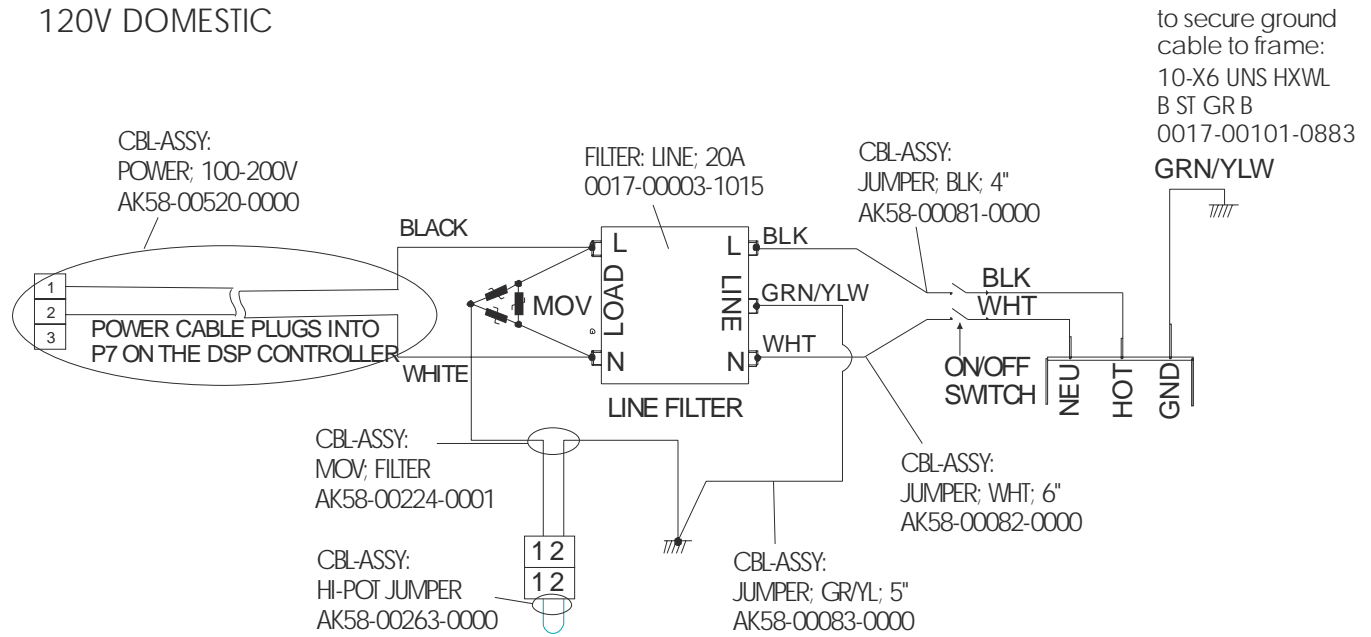

200-240V ONLY

