

EUREKA

Home Cleaning System Vacuum Cleaner

Household Type

Owner's Guide 6850 Series

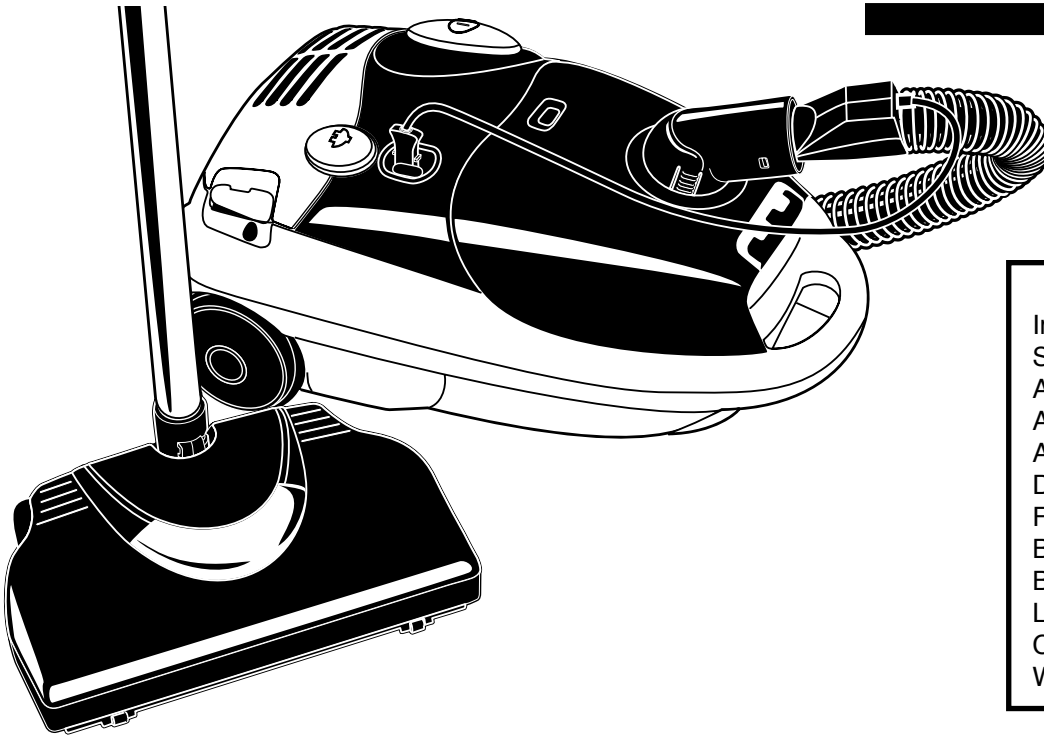

Index

Important Safeguards	2
Service Information	4
Automatic Motor Shut-Off	4
Assembly & Use	5-6
Accessories	7
Dust Bag	8
Filters	9
Brush Roll	10
Brush Roll Belt	10
Light Bulb	10
Customer Order Form	11-12
Warranty	13

IMPORTANT:

Please record the model, type and serial numbers below. You will be asked for them when inquiring about accessories or service. They can be found on the silver rating plate attached to your cleaner. It is also suggested that you keep your sales receipt attached. You may need it for verification of your date of purchase.

Model No. & Type _____

Serial No. _____

IMPORTANT SAFEGUARDS

When using an electrical appliance, basic precautions should always be followed, including the following:

READ ALL INSTRUCTIONS BEFORE USING THIS VACUUM CLEANER.

WARNING

To reduce the risk of fire, electric shock, or injury:

- Do not use outdoors or on wet surfaces.
- **Do not leave vacuum cleaner when plugged in.** Turn off the switch and unplug the electrical cord when not in use and before servicing.
- Do not allow to be used as a toy. Close attention is necessary when used by or near children.
- Use only as described in this manual. Use only manufacturer's recommended attachments.
- Do not use with damaged cord or plug. If vacuum cleaner is not working as it should, has been dropped, damaged, left outdoors, or dropped into water, return it to a service center before using.
- Do not pull or carry by cord, use cord as a handle, close a door on cord, or pull cord around sharp edges or corners. Do not run vacuum cleaner over cord. Keep cord away from heated surfaces.
- Hold plug when rewinding onto cord reel. Do not allow plug to whip when rewinding.
- Do not use extension cords or outlets with inadequate current carrying capacity.
- Turn off all controls before unplugging.
- Always turn off this appliance before connecting or disconnecting either hose or motorized nozzle.
- Do not unplug by pulling on cord. To unplug, grasp the plug, not the cord.
- The hose contains electrical wires. Do not use if damaged, cut or punctured. Avoid picking up sharp objects.
- Do not handle plug or vacuum cleaner with wet hands.
- Do not put any object into openings. Do not use with any opening blocked; keep free of dust, lint, hair, and anything that may reduce airflow.
- This vacuum cleaner creates suction and contains a revolving brush roll. Keep hair, loose clothing, fingers, and all parts of body away from openings and moving parts.
- Do not pick up anything that is burning or smoking, such as cigarettes, matches, or hot ashes.
- Do not use without dust bag in place.
- Belt pulleys can become hot during normal use. To prevent burns, avoid touching the belt pulley when servicing the drive belt.
- Use extra care when cleaning on stairs.
- Do not use to pick up flammable or combustible liquids such as gasoline, or use in areas where they may be present.
- Store your cleaner in a cool, dry area.
- Keep your work area well lighted.
- Unplug electrical appliances before vacuuming them.

SAVE THESE INSTRUCTIONS

To reduce the risk of electric shock, this appliance has a polarized plug (one blade is wider than the other). The plug will fit in a polarized outlet only one way. If the plug does not fit fully in the outlet, reverse the plug. If it still does not fit, contact a qualified electrician to install the proper outlet. Do not change the plug in any way.

Afin de réduire le risque de choc électrique, cet appareil est muni d'une fiche polarisée (une des lames est plus large). Cette fiche ne peut être insérée dans une prise polarisée que d'une seule façon. Si la fiche ne peut être insérée dans la prise, retourner la fiche. Si la fiche ne peut toujours pas être insérée dans la prise, faire installer une prise adéquate par un électricien qualifié. Ne pas modifier la fiche.

GENERAL INFORMATION

The bag may have come dislodged in shipping. Check the bag to insure proper seating before attempting to use the cleaner. Do not operate the cleaner without a dust bag or the filters. Damage may result to the motor (see Dust Bag and Filter).

The cleaner is designed to pick up dirt and dust particles. Avoid picking up hard or sharp objects with the cleaner to avoid bag breakage, hose clogging, or possible motor damage.

Service Information

The instructions in this booklet serve as a guide to routine maintenance. If additional service is required, telephone toll free:

Mexico: 5670-6169

If you prefer, you can write to Electrolux Home Care Products, Consumer Service, P.O. Box 3900, Peoria, Illinois 61612, USA. In Canada write to Electrolux Home Care Products, 866 Langs Drive, Cambridge, Ontario N3H 2N7. Refer to The Electrolux Limited Warranty for complete service information.



DO NOT OIL the motors (in the canister and the motorized nozzle) or the brush roll at any time. The bearings are permanently lubricated and sealed.

Rating Plate

The model, type and serial numbers are indicated on the rating plate located on the underneath side of the cleaner. For prompt and complete service information, always refer to these numbers when inquiring about service.

Model No. & Type _____

Serial No. _____

MODEL	TYPE	SERIAL NO.
127	10	60
VOLTS HOUSEHOLD TYPE	AMPS. SERVICE INFORMATION: 1-800-282-2886	HERTZ
EUREKA BLOOMINGTON, ILLINOIS 61701		

Automatic Motor Shut-Off

To protect from overheating, this vacuum cleaner is equipped with a thermostat which automatically shuts off the motor if it overheats. Should this happen:

1. **Turn off the switch and unplug** the cleaner because the thermostat will allow the cleaner to automatically start running again when the motor cools (approximately 30 minutes).
2. **Check the hose, bag, and filters** as a clogged hose, full bag, or dirty filters could cause the motor to overheat.
3. **Call a Eureka Service Station** if the cleaner will not operate after cooling for approximately 30 minutes.

ASSEMBLY ITEMS

NOTE: Unpack and identify all parts. Fully assemble before using.

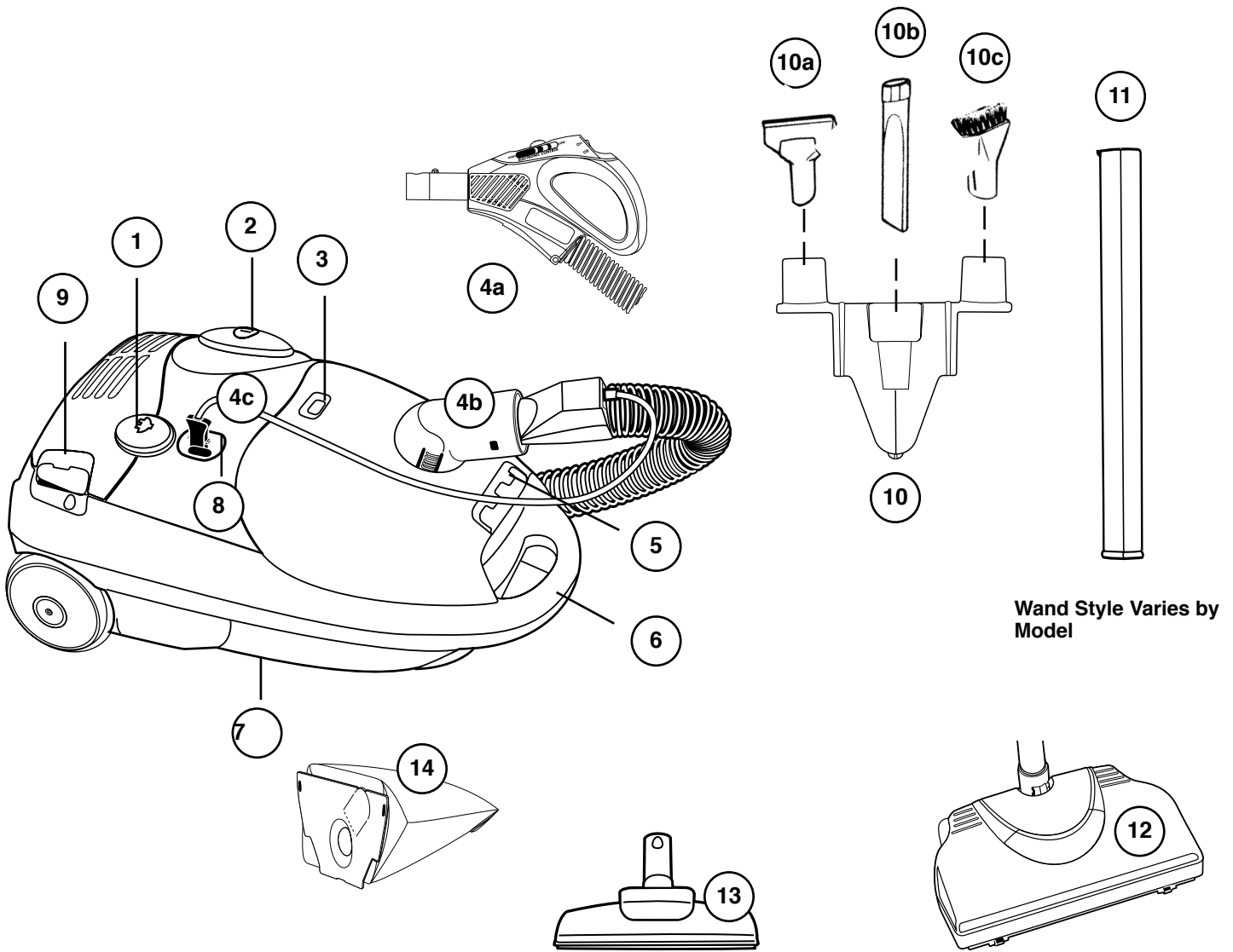

1. Cord Rewind Button
2. Power Switch
3. Bag Change Indicator
4. Hose has Handle with remote controls (4a) and coupling (4b) with plug (4c).
See instructions on pages 6 and 7.
5. Bag Cover Latch
6. Carrying Handle
7. Parking slot for bare floor nozzle is located on the bottom and rear of the canister.
8. Hose Plug Connection
9. Exhaust Filter Compartment Latch
10. Tool Caddy
 - a) Upholstery Nozzle
 - b) Crevice Tool
 - c) Dusting Brush
11. Button-Lock Integrated Extension Wands (2 wand set)
12. Motorized Nozzle
13. Floor Brush
14. Disposable Dust Bags

Always carry the vacuum by the handle when cleaning steps, etc.

How to Assemble and Use

POWER-TOUCH® Handle

Remote ON/OFF Selector for bare floor or carpet

*Off – push down on front

Bare Floor – push down on back

*Power ON/OFF for canister can only be controlled by canister ON/OFF switch.

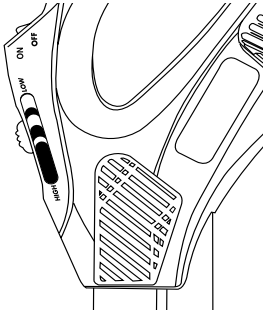

Vacuum Control

Cleaning suction is reduced by pushing lever to LOW position. Place lever at HIGH position to increase suction for carpet cleaning.

1. Snap interlocking wands together.
2. Push assembled wands into power nozzle.
3. Place Power-Touch hose handle into wands until plug connects and button locks.
4. Insert hose coupling into top of canister and push hose power cord into receptacle located on top of canister. The outlet has a protection side cover which must be moved slightly towards the rear of the cleaner before plug will go into the outlet. Make sure plug is fully seated in the outlet or the motorized power nozzle may not function.
5. Pull on electrical cord and push plug into outlet. To rewind, step on Cordaway cord reel button, hold and guide plug while it rewinds.
6. Step on handle release on the motorized nozzle to release handle; pull back to comfortable work position.
7. Push On/Off canister switch.
(A thermostat automatically shuts off the motor if it overheats, see Automatic Motor Shut-Off.)
8. Bare floor or carpet cleaning selection on remote control, only.

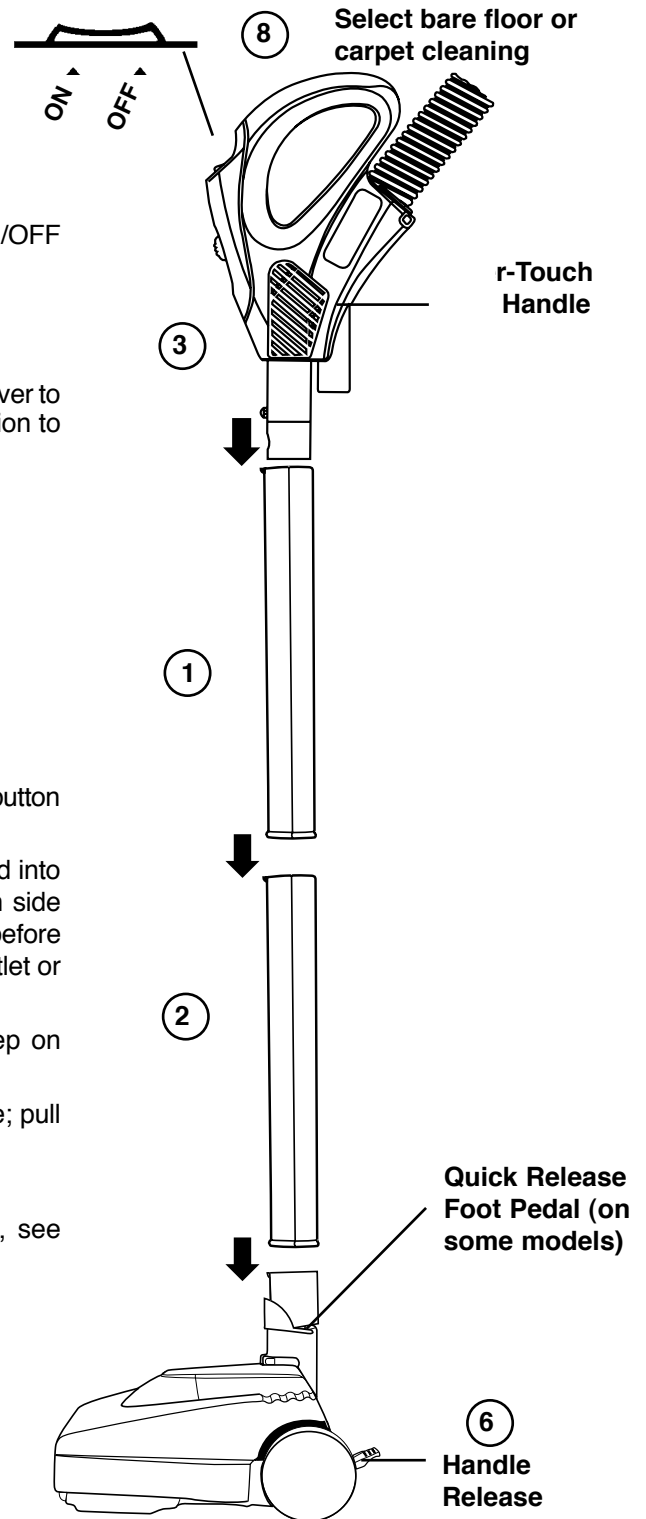
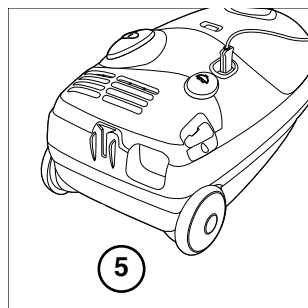
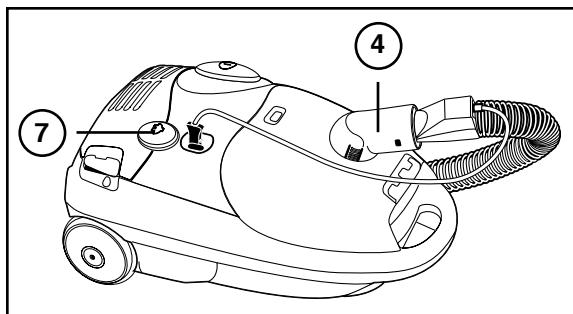

Tools

11. The tool caddy fits into the floor tool parking position slot on the rear of the cleaner.

a. Dusting brush. For furniture, blinds, books, lamp shades, shelves.

b. Crevice tool. For corners, baseboards, between cushions, sliding door tracks.

c. Upholstery nozzle. For curtains, draperies, cushions, fabrics.

d. Floor brush. (On some models.) For paneled walls, ceilings, beams, bare floor surfaces.

a

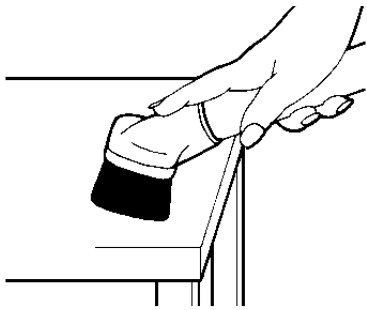

b

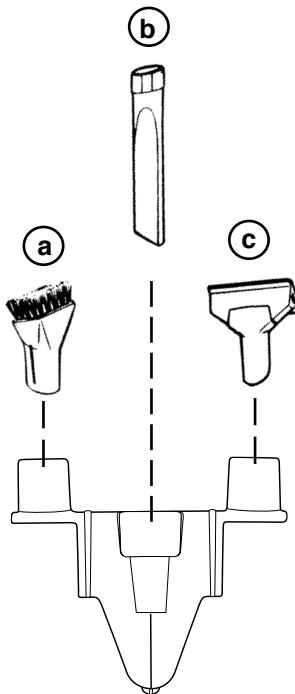
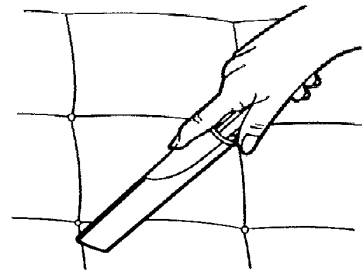

c

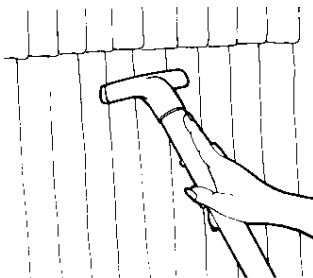

d

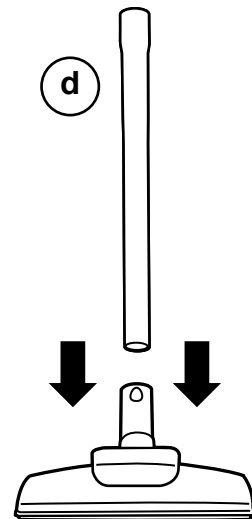

HOW TO MAINTAIN

The paper bag and filters play a very important role in the efficiency of the vacuum cleaner. The purpose of the paper bag is to trap dirt and at the same time the paper must be porous enough to allow air to pass through. If the paper bag or filters become clogged, no air can pass through the cleaner and no cleaning takes place regardless of how powerful the unit. To keep the cleaner operating at maximum efficiency, change the dust bag frequently and clean the filters as necessary.

Some fine particles can restrict airflow very quickly and will decrease performance even before the bag appears to be full. When vacuuming carpet fresheners or cleaners, plaster dust, or similar fine substances, clean the bag and filters more often.

Bag Change Indicator

The bag change indicator bar fills as the airflow through the bag decreases. Certain types of fine particles like powder, plaster dust, or carpet fibers can restrict airflow very quickly and will decrease performance even before the bag appears to be full. When the warning appears, change the disposable dust bag to restore maximum performance. If a clean dust bag does not restore maximum performance, clean the filters and check the hose and wands for obstructions.

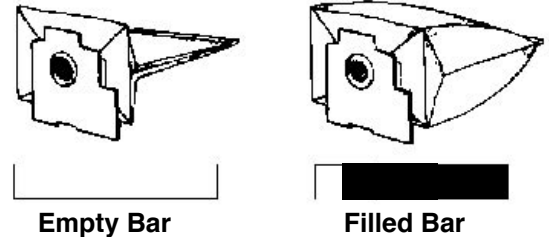

HOW TO CHANGE DISPOSABLE DUST BAG

NOTE: Turn off the power switch and disconnect electrical cord from wall socket before changing dust bag. Never use the cleaner without a dust bag or filters.

To remove used dust bag:

1. Unplug the hose plug to open the lid of bag compartment.
2. Push the bag's cardboard disc closed, grasp the cardboard collar and lift out the full bag.

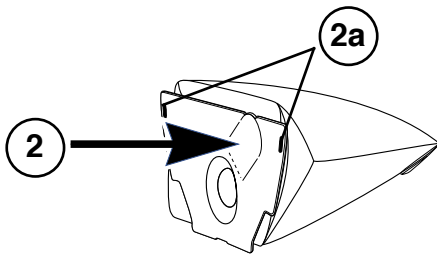

To install new dust bag:

3. Put in the new dust bag (part number 60284) by placing holes (2a) in upper corners of bag collar on pegs inside the cleaner (3a). Make sure bag collar is secured under the bag clip (3b). Spread dust bag open as much as possible within the cleaner to maximize performance. (The bag compartment lid will not latch without dust bag properly in place.)

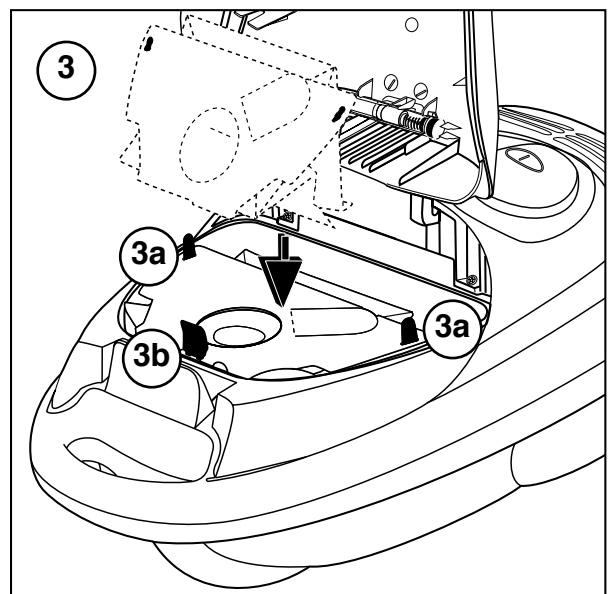
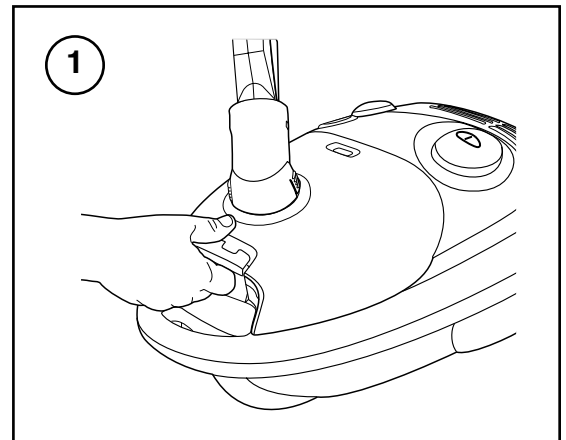

Filters

For maximum efficiency, be sure to maintain the motor filter and the final filter regularly.

Motor Filter

Inspect the motor filter with each disposable dust bag change.

The motor filter in the dust bag compartment should be cleaned when necessary or about twice a year.

1. Open the cover, remove disposable dust bag and lift motor filter out of compartment
2. Shake out thoroughly.
3. To replace cleaned filter or install a new filter, fit into the bottom of compartment under two ribs (3a).

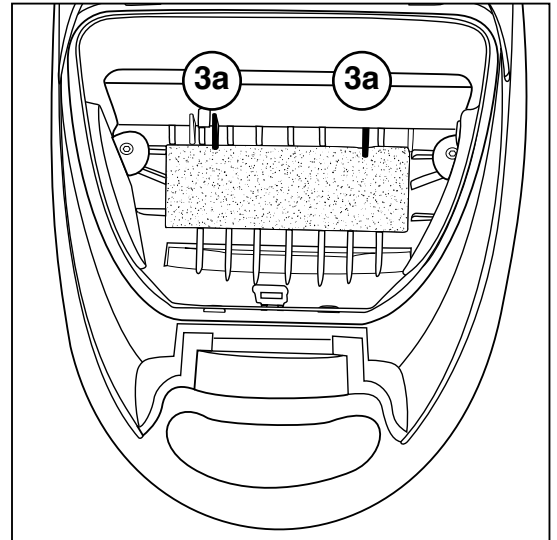

Exhaust Filter

Check the exhaust filter with each disposable dust bag change. Replace after every three bag changes or when obviously dirty. A new exhaust filter is included in every three pack of bags.

1. Remove filter cover. Press in on latch on filter cover and lift cover upward.
2. Using finger tab on filter, lift filter out of compartment.
3. Put in new exhaust filter.
4. Replace filter cover. Place tab on filter cover into notch on cleaner. Use a gentle twisting motion to seat tab. Swing filter cover down against cleaner until latch clicks shut.

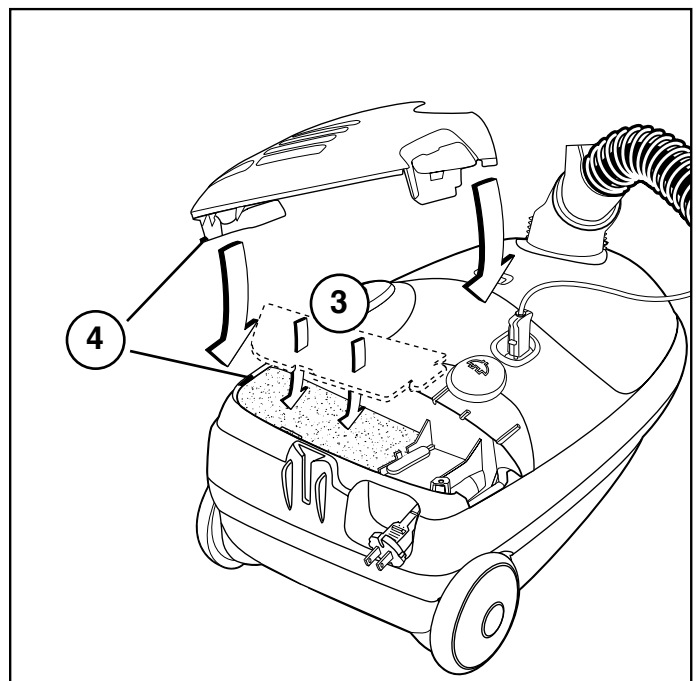
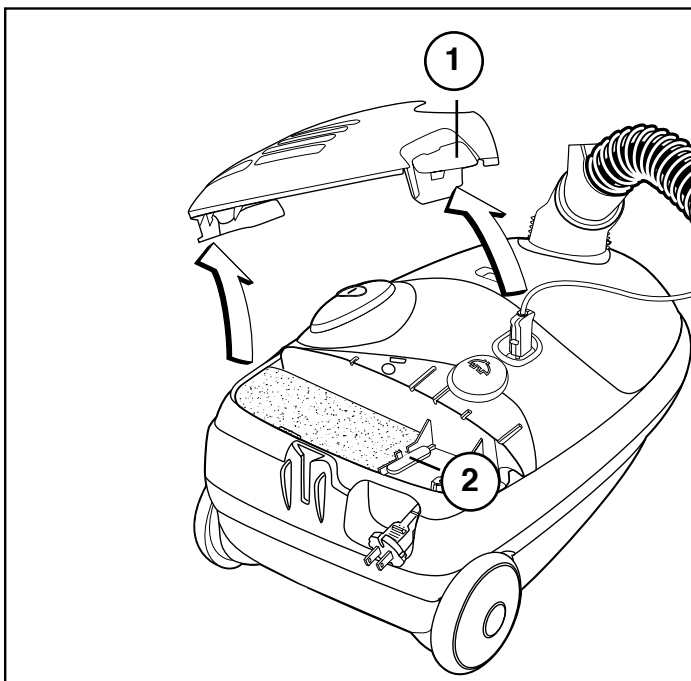

Brush Roll

The brush roll turns to sweep and comb the carpet nap. Keep the brush roll free from hair and threads so it will continue cleaning. When the bristles of the brush roll no longer touch a piece of cardboard held across the bottom plate, the brush roll is ineffective because the bristles no longer touch the carpet nap. To maintain the most effective cleaning, install a new brush roll.

Brush Roll Belt and Light Bulb

The brush roll belt on the motorized nozzle drives the brush roll to agitate, sweep, and comb the carpet nap. The belt should be checked regularly to be sure that it is in good condition. Replace the belt if it is stretching, cracking, or slipping. Cut away any hair or thread wound around the brush roll or belt pulley because the buildup could cause the belt to rotate unevenly.

How to Replace Worn Belt or Light Bulb (On Some Models)

NOTE: Turn off the switch and unplug the electrical cord before replacing belt or bulb. Pulleys can become hot during normal use. To prevent injury, avoid touching the pulleys when servicing the drive belt.

1. Remove six screws from bottom side. Turn unit over; pull up on hood to remove.

Replace light bulb, if necessary. Use GENUINE EUREKA replacement bulb, 59045.

Continue to step 2 to change belt. Skip to step 7 to replace hood.

2. Lift out brush roll and discard used belt.
3. Put new belt around brush roll pulley first; then the motor pulley.
4. Place left end cap into the base.
5. Pull right end of brush roll to stretch belt. Secure right end cap into base.
6. Rotate brush roll to seat belt.
7. Position hood; secure with screws.

Use GENUINE EUREKA replacement belt, 58065.

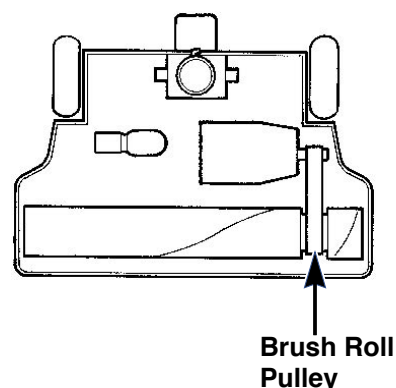
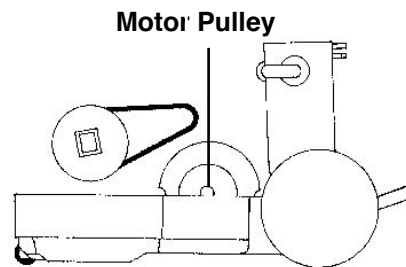
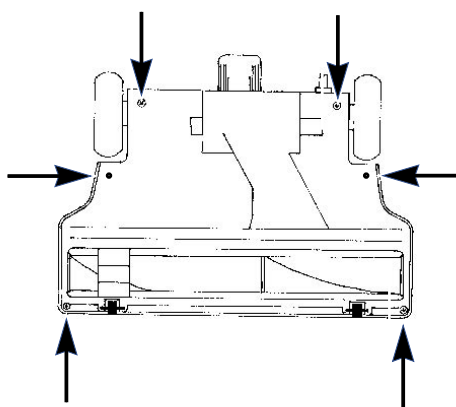

THE EUREKA LIMITED WARRANTY

What This Warranty Covers

Your Eureka cleaner is warranted to be free from all defects in material and workmanship in normal household use for a period of one year. The warranty is granted only to the original purchaser and members of his or her immediate household. The warranty is subject to the following provisions.

What This Warranty Does Not Cover

- Parts of the cleaner that require replacement under normal use, such as disposable dust bags, filters, drive belts, light bulbs, brush roll bristles, impellers and cleaning.
- Damages or malfunctions caused by negligence, abuse, or use not in accordance with the Owner's Guide.
- Defects or damages caused by unauthorized service or the use of other than Genuine Eureka parts.

What Electrolux Home Care Products Will Do

Electrolux Home Care Products will, at its option, repair or replace a defective cleaner or cleaner part that is covered by this warranty. As a matter of warranty policy, Electrolux Home Care Products will not refund the consumer's purchase price.

Warranty Registration

Please fill out and return the warranty registration card accompanying your cleaner.

Obtaining Warranty Service

To obtain warranty service you must return the defective cleaner or cleaner part along with proof of purchase to any Eureka Authorized Warranty Station. You will find the nearest location in the Yellow Pages, under "Vacuum Cleaners—Service and Repair." Be certain that the Warranty Station is "Eureka Authorized." For the location of the nearest Eureka Authorized Warranty Station or for service information, telephone toll free:

USA: 1-800-282-2886
Mexico: 5670-6169
Canada: 1-800-282-2886

If you prefer, you can write to Electrolux Home Care Products North America, P.O. Box 3900, Peoria, Illinois 61612, USA. In Canada write to Electrolux Home Care Products Canada, 866 Langs Drive, Cambridge, Ontario N3H 2N7.

If it is necessary to ship the cleaner outside your community to obtain warranty repair, you must pay the shipping charges to the Eureka Authorized Warranty Station. Return shipping charges will be paid by the Warranty Station. When returning parts for repair, please include the model, type, and serial number from the data plate on the cleaner.

Further Limitations and Exclusions

Any warranty that may be implied in connection with your purchase or use of the cleaner, including any warranty of Merchantability or any warranty for Fitness For A Particular Purpose is limited to the duration of this warranty. Some states do not allow limitations on how long an implied warranty lasts, so the above limitations may not apply to you.

Your relief for the breach of this warranty is limited to the relief expressly provided above. In no event shall Eureka be liable for any consequential or incidental damages you may incur in connection with your purchase or use of the cleaner. Some states do not allow the exclusion or limitation of incidental or consequential damages, so the above limitation or exclusion may not apply to you.

This warranty gives you specific legal rights. You may also have other rights which vary by state.



Questions & Answers about Genuine Eureka Products

Q: Why should I use only Genuine Eureka paper bags, belts, and parts in my Eureka vacuum cleaner?

A: Using Genuine Eureka Products, which are made to our exacting specifications and engineered with emphasis on quality, performance, and customer satisfaction, ensures the long life and cleaning efficiency of your vacuum cleaner. Overall, this saves you money and helps to keep your home clean.

Q: How can I be sure I am using only genuine Eureka products in my vacuum cleaner?

A: Typically, packaged products and paper bags can be identified by a "Genuine Eureka Product" symbol (see illustration above). For further identification assistance, you may call our toll-free number, 1-800-282-2886, for the location of a nearby Eureka Authorized Warranty Station.

Q: Are there any differences between "made to fit" or "imitation" and Genuine Eureka paper bags, belts, and parts?

A: Yes, there are some very important differences in materials, quality, and reliability. Many customers have mistakenly purchased "imitation" paper bags and parts while thinking they purchased genuine. Unfortunately, many of these customers discovered the differences after they experienced related difficulties.

For Genuine Eureka Value, Accept No Imitations!
ELECTROLUX HOME CARE PRODUCTS

Bloomington, Illinois 61701



POLIZA DE GARANTIA ASPIRADORAS

Producto Importado y Distribuido por:
ELECTROLUX COMERCIAL, S.A. DE C.V.
AV. DE LA INDUSTRIA No. 951, PARQUE INDUSTRIAL A.J. BERMUDEZ,
C.P. 32470 CIUDAD JUAREZ CHIHUAHUA, MEXICO
TEL. 6566250356

GARANTIA

ELECTROLUX COMERCIAL, S.A. DE C.V. Garantiza por el termino de 1 año sus productos contra cualquier defecto de fabricación en todos sus componentes y mano de obra a partir de la fecha original de compra.

Procedimientos para hacer efectiva la garantía: (CONDICIONES)

- 1.- Para hacer efectiva esta garantía, no podrá exigirse mayores requisitos que la presentación de "COPIA": FACTURA DE COMPRA, Y "COPIA" DE LA POLIZA DE GARANTIA con el producto, en el lugar donde este fue adquirido o en los centros de Servicio autorizados por ELECTROLUX COMERCIAL, S.A. DE C.V.
- 2.- La compañía se compromete a reparar o cambiar este producto y todas las partes defectuosas sin cargo alguno, en caso de que a juicio de la Empresa no sea posible la reparación.
3. El consumidor puede obtener las partes, componentes, consumibles, accesorios en nuestro:

CENTRO DE SERVICIO MATRIZ:
CENTRO DE SERVICIO VAZQUEZ
Calz. Echegaray # 28 Col. Rivera de Echegaray
Naucalpan edo de Mexico C.P. 53329
5373-8942

y/o en cualquiera de nuestros Centros de Servicio Autorizados en toda la República Mexicana.

Clausulas

Soló puede eximirse de hacer efectiva la garantía en los siguientes casos:

- a) Cuando el producto ha sido utilizado en condiciones distintas a las normales.
- b) Cuando el producto no ha sido operado de acuerdo al Instructivo de uso, en Idioma español, proporcionado.
- c) Cuando el producto ha sido alterado o reparado por personas no autorizadas por la empresa ELECTROLUX COMERCIAL, S.A. DE C.V.

NOTA: En caso de que la presente garantía se extraviara. El consumidor puede recurrir a su proveedor para que le expida otra Póliza de Garantía, previa presentación de la Nota de Compra o factura respectiva.

El manejo, instalación y precauciones, vienen descritas detalladamente en el manual.

NOM

LA GARANTÍA ESTA EN EL NOM

Nombre del comprador:			
Domicilio:		Teléfono:	
Nombre del distribuidor:			
Domicilio:		Teléfono:	
Producto:	Modelo:	Marca:	Serie:
No. De factura de compra:		Fecha de adquisición del producto:	
Firma del distribuidor y sello:			

