

**RIDGID
R5013 1/2 in. HAMMER DRILL
REPAIR SHEET**

**RIDGID
PERCEUSE À PERCUSSION DE 13 mm
(1/2 po) R5013
FEUILLE DE RÉPARATION**

**RIDGID
R5013 TALADRO DE PERCUSIÓN
DE 13 mm (1/2 pulg.)
LISTAS DE PIEZAS DE REPUESTO**

RIDGID® R5013

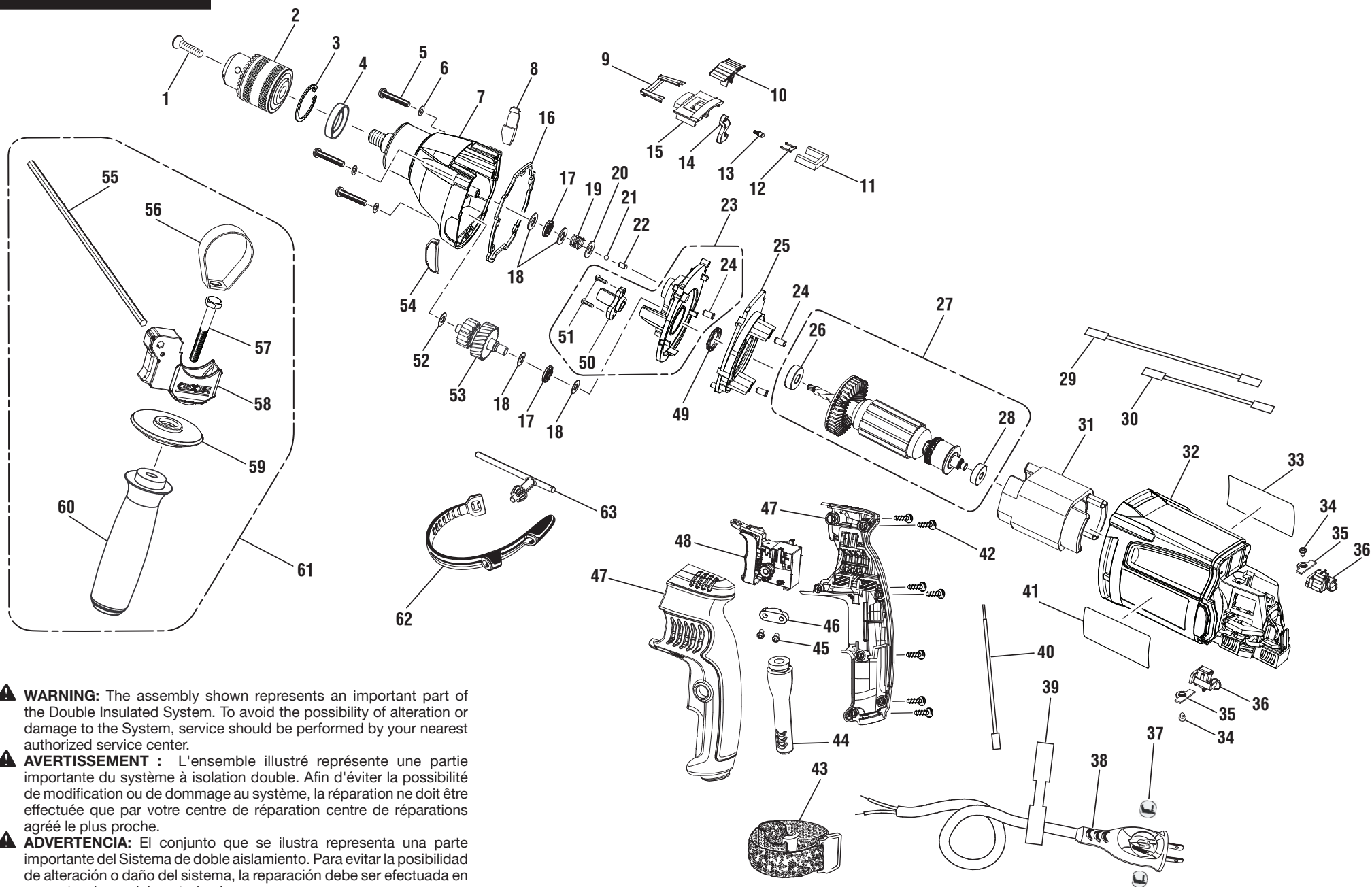

⚠ WARNING: The assembly shown represents an important part of the Double Insulated System. To avoid the possibility of alteration or damage to the System, service should be performed by your nearest authorized service center.

⚠ AVERTISSEMENT : L'ensemble illustré représente une partie importante du système à isolation double. Afin d'éviter la possibilité de modification ou de dommage au système, la réparation ne doit être effectuée que par votre centre de réparation agréé le plus proche.

⚠ ADVERTENCIA: El conjunto que se ilustra representa una parte importante del Sistema de doble aislamiento. Para evitar la posibilidad de alteración o daño del sistema, la reparación debe ser efectuada en su centro de servicio autorizado.

RIDGID® R5013

KEY	P/N	DESCRIPTION	QTY	KEY	P/N	DESCRIPTION	QTY	KEY	P/N	DESCRIPTION	QTY
1	6613402	SCREW (M6 X 27 mm)	1	23	301957001	GEAR BOX COVER ASSEMBLY (INCL. KEY NOS. 24, 50, AND 51)	1	44	560801001	BEND RELIEF	1
2	672380001	CHUCK	1	24	560712001	RUBBER KNOCK	3	45	6627201	* SCREW (M4 X 14 mm)	2
3	671025001	RETAINING RING (32 mm)	1	25	513698001	FAN CASE	1	46	5950101	CORD CLAMP	1
4	901002003	OIL SEAL	1	26	680141014	BALL BEARING (608 LLU)	1	47	300160013	HANDLE ASSEMBLY	1
5	660024019	* SCREW (M4 X 34 mm)	3	27	200216021	ARMATURE ASSEMBLY (INCL. KEY NOS. 26 AND 28)	1	48	760406003	SWITCH	1
6	670030002	SPRING WASHER	3	28	6972701	BALL BEARING (626Z)	1	49	570593001	SEAL RING	1
7	300308033	GEAR BOX ASSEMBLY	1	29	290102006	WIRE ASSEMBLY (90 mm)	1	50	672026001	ARMATURE SHAFT SUPPORT	1
8	513922001	ANTI-SKID PAD (RIGHT)	1	30	290102007	WIRE ASSEMBLY (55 mm)	1	51	660320004	* SCREW (M3.5 X 10 mm)	2
9	570598001	SEAL RING	1	31	740940001	FIELD ASSEMBLY	1	52	631813001	WASHER	1
10	513642001	IMPACT BUTTON	1	32	200058009	MOTOR HOUSING ASSEMBLY	1	53	300022010	GEAR SHAFT ASSEMBLY	1
11	901241001	SPONGE SEAL	1	33	940045024	DATA LABEL	1	54	513923001	ANTI-SKID PAD (LEFT)	1
12	631486001	CATCH RING	1	34	660203046	* SCREW (M3 X 6 mm)	2	55	620448001	DEPTH STOP ROD	1
13	301603001	CAP ASSEMBLY	1	35	513689001	PRESSURE PLATE	2	56	620451001	SPRING PLATE	1
14	631485001	IMPACT KEY	1	36	290069080	BRUSH ASSEMBLY	2	57	660169228	* SCREW (M8 X 62 mm)	1
15	513641001	IMPACT HOUSING	1	37	941304001	AC PLUG ICON LABEL	2	58	301459004	CARRIER ASSEMBLY	1
16	570603001	SEAL RING	1	38	730401010	POWER CORD	1	59	513694001	AUXILIARY HANDLE CAP	1
17	681012001	TRUST BEARING	2	39	940299942	CORD TAG	1	60	301374002	AUXILIARY HANDLE	1
18	631504001	WASHER	4	40	290102005	WIRE ASSEMBLY (95 mm)	1	61	301374003	AUXILIARY HANDLE ASSEMBLY (INCL. KEY NOS. 55-60)	1
19	671871001	SPRING	1	41	940114139	LOGO LABEL	1	62	560989001	CHUCK KEY STRAP	1
20	631483001	WASHER	1	42	660024007	* SCREW (M4 X 16 mm)	7	63	690176004	CHUCK KEY	1
21	671401002	BALL	1	43	300904001	CORD WRAP ASSEMBLY	1		901054003	CANVAS BAG (NOT SHOWN)	1
22	631500001	PIN	1						987000060	OPERATOR'S MANUAL (NOT SHOWN)	1

02-12-07
(REV:00)

RIDGID® R5013

PIÈCE	RÉF.	DESCRIPTION	QTÉ	PIÈCE	RÉF.	DESCRIPTION	QTÉ	PIÈCE	RÉF.	DESCRIPTION	QTÉ
1	6613402	VIS (M6 X 27 mm).....	1	23	301957001	COUVERCLE DE CARTER D'ENGRENAGES (INCL. PIÈCES NO. 24, 50, ET 51)	1	44	560801001	TUBE DE SÉCURITÉ.....	1
2	672380001	MANDRIN	1					45	6627201	*VIS (M4 X 14 mm).....	2
3	671025001	BAGUE D'RETENIR (32 mm).....	1	24	560712001	COUP DE CAOUTCHOUC	3	46	5950101	RETENUE DE CORDON.....	1
4	901002003	JOINT PETROLE	1	25	513698001	CARTER DE VENTILATEUR	1	47	300160013	POIGNÉE.....	1
5	660024019	*VIS (M4 X 34 mm).....	3	26	680141014	ROULEMENT (608 LLU).....	1	48	760406003	INTERRUPTEUR	1
6	670030002	RONDELLE ÉLASTIQUE	3	27	200216021	INDUIT (INCL. PIÈCES NO. 26 ET 28).....	1	49	570593001	BAGUE D'ÉTANCHÉITÉ	1
7	300308033	COUVERCLE DE D'ENGRENAGES	1	28	6972701	ROULEMENT (626Z)	1	50	672026001	ARBRE DE INDUIT SUPPORT	1
8	513922001	PATIN ANTIDÉRAPANT (DROIT).....	1	29	290102006	FIL DE CONNEXION (90 mm)	1	51	660320004	*VIS (M3.5 X 10 mm).....	2
9	570598001	BAGUE D'ÉTANCHÉITÉ	1	30	290102007	FIL DE CONNEXION (55 mm)	1	52	631813001	WASHER	1
10	513642001	BOUTON À IMPACT.....	1	31	740940001	FIL DE CHAMP.....	1	53	300022010	ARBRE D'ENGRENAGES.....	1
11	901241001	JOINT ÉPONGE	1	32	200058009	CARTER MOTEUR	1	54	513923001	PATIN ANTIDÉRAPANT (GAUCHE)	1
12	631486001	BAGUE DE PRISE	1	33	940045024	PLAQUETTE SIGNALÉTIQUE	1	55	620448001	TIGE DE BUTÉE DE PROFONDEUR.....	1
13	301603001	BOUCHON	1	34	660203046	*VIS (M3 X 6 mm).....	2	56	620451001	PLAQUE À RESSORT	1
14	631485001	CLÉ À IMPACT	1	35	513689001	PLAQUE DE PRESSION.....	2	57	660169228	*VIS (M8 X 62 mm)	1
15	513641001	BOÎTIER À IMPACT	1	36	290069080	BALAI	2	58	301459004	SUPPORT.....	1
16	570603001	BAGUE D'ÉTANCHÉITÉ	1	37	941304001	AUTOCOLLANT DE BOUCHON	2	59	513694001	BOUCHON DE POIGNÉE AUXILIAIRE.....	1
17	681012001	CONFIANCE ROULEMENT	2	38	730401010	CORDON D'ALIMENTATION.....	1	60	301374002	POIGNÉE AUXILIAIRE.....	1
18	631504001	RONDELLE.....	4	39	940299942	ÉTIQUETTE DU CORDON.....	1	61	301374003	FIL DE POIGNÉE AUXILIAIRE (INCL. PIÈCES NO. 55-60)	1
19	671871001	RESSORT	1	40	290102005	FIL DE CONNEXION (95 mm)	1	62	560989001	ATTACHE DE CLÉ DE MANDRIN	1
20	631483001	RONDELLE.....	1	41	940114139	AUTOCOLLANT DE LOGO	1	63	690176004	CLÉ À MANDRIN.....	1
21	671401002	BILLE	1	42	660024007	*VIS (M4 X 16 mm).....	7		901054003	SACOCHE (NON ILLUSTRÉE)	1
22	631500001	BROCHE	1	43	300904001	ENROULEMENT DE CORDON	1		987000060	MANUEL D'UTILISATION (NON ILLUSTRÉ).....	1

REF.	N/P	DESCRIPCIÓN	CANT.	REF.	N/P	DESCRIPCIÓN	CANT.	REF.	N/P	DESCRIPCIÓN	CANT.
1	6613402	TORNILLO (M6 X 27 mm).....	1	23	301957001	CONJUNTO DE LA TAPA DE LA CAJA DE ENGRANAJES (INCL. PZAS. NÚMS. REF. 24, 50, Y 51)	1	43	300904001	CONJUNTO DE SOPORTE PARA ENROLLAR EL CORDÓN.....	1
2	672380001	PORTABROCAS	1					44	560801001	PROTECTOR DEL CORDÓN	1
3	671025001	ANILLO DE RETENER (32 mm).....	1	24	560712001	GOLPE DE CAUCHO	3	45	6627201	* TORNILLO (M4 X 14 mm).....	2
4	901002003	ANILLO DE ACEITE.....	1	25	513698001	ESTUCHE DEL VENTILADOR.....	1	46	5950101	ABRAZADERA DEL CORDÓN	1
5	660024019	* TORNILLO (M4 X 34 mm).....	3	26	680141014	COJINETE DE BOLAS (608 LLU)	1	47	300160013	CONJUNTO DEL MANGO	1
6	670030002	ARANDELA ELÁSTICA.....	3	27	200216021	CONJUNTO DEL INDUCIDO (INCL. PZAS. NÚMS. REF. 26 Y 28)	1	48	760406003	INTERRUPTOR	1
7	300308033	CONJUNTO DE LA CAJA DE ENGRANAJES	1	28	6972701	COJINETE DE BOLAS (626Z).....	1	49	570593001	ANILLO DE SELLADO	1
8	513922001	ALMOHADILLA ANTIDESLIZANTE (DERECHA).....	1	29	290102006	CONJUNTO DEL CABLE (90 mm)	1	50	672026001	SOPORTE DE EJE DE INDUCIDO	1
9	570598001	ANILLO DE SELLADO	1	30	290102007	CONJUNTO DEL CABLE (55 mm)	1	51	660320004	* TORNILLO (M3.5 X 10 mm).....	2
10	513642001	BOTÓN DEL IMPACTO	1	31	740940001	CONJUNTO DEL CAMPO.....	1	52	631813001	ARANDELA.....	1
11	901241001	ANILLO DE ESPONJA.....	1	32	200058009	CONJUNTO DEL ALOJAMIENTO DEL MOTOR.....	1	53	300022010	CONJUNTO DEL EJE DEL ENGRANAJE....	1
12	631486001	ANILLO DE CIERRE	1	33	940045024	ETIQUETA DE DATOS	1	54	513923001	ALMOHADILLA ANTIDESLIZANTE (IZQUIERDA)	1
13	301603001	CONJUNTO DEL TAPA	1	34	660203046	* TORNILLO (M3 X 6 mm).....	2	55	620448001	CALIBRADOR DE PROFUNDIDAD	1
14	631485001	LLAVE DEL IMPACTO	1	35	513689001	ESCOBILLA A PRESIÓN.....	2	56	620451001	PLACA DE RESORTE.....	1
15	513641001	ALOJAMIENTO DEL IMPACTO.....	1	36	290069080	ESCOBILLA.....	2	57	660169228	* TORNILLO (M8 X 62 mm)	1
16	570603001	ANILLO DE SELLADO	1	37	941304001	ETIQUETA TAPÓN.....	2	58	301459004	CONJUNTO DEL PORTADOR.....	1
17	681012001	COJINETE DE CONFIANZA	2	38	730401010	CORDÓN DE CORRIENTE.....	1	59	513694001	TAPA DEL MANGO AUXILIAR.....	1
18	631504001	ARANDELA.....	4	39	940299942	ETIQUETA DEL CORDÓN	1	60	301374002	MANGO AUXILIAR	1
19	671871001	RESORTE.....	1	40	290102005	CONJUNTO DEL CABLE (95 mm)	1	61	301374003	CONJUNTO DEL MANGO AUXILIAR (INCL. PZAS. NÚMS. REF. 55-60)	1
20	631483001	ARANDELA.....	1	41	940114139	ETIQUETA LOGOTIPO	1	62	560989001	CORREA DE LALLAVE DEL PORTABROCAS	1
21	671401002	BOLA	1	42	660024007	*TORNILLO (M4 X 16 mm)	7	63	690176004	LLAVE DEL PORTABROCAS.....	1
22	631500001	PASADOR.....	1						901054003	BOLSA (NO SE ILUSTRA)	1
									987000060	MANUAL DEL OPERADOR (NO SE ILUSTRA).....	1