

Service and Parts Manual



F R I E D R I C H



Models

Indoor Units	MW18Y3H	MW18Y3H
--------------	---------	---------

Outdoor Units	MR24Y3H	MR24Y3H
---------------	---------	---------

CUSTOMER SATISFACTION and QUALITY ASSURANCE

Friedrich is a conscientious manufacturer, concerned about customer satisfaction, product quality, and controlling warranty costs. As an Authorized Service Provider you play a vital role in these areas. By adhering to the policies and procedures you provide us with vital information on each warranty repair you complete. This information is used to identify product failure trends, initiate corrective action, and improve product quality, thereby further reducing warranty expenses while increasing customer satisfaction levels.

FRIEDRICH AUTHORIZED PARTS DEPOTS

AAA Refrigeration Service

1322 24th Street, Suite B
Kenner, Louisiana 70062
504-464-7444
877-813-7444

The Gabbert Company

6868 Ardmore
Houston, Texas 77054
713-747-4110
800-458-4110

Reeve Air Conditioning, Inc.

2501 South Park Road
Hallandale, Florida 33009
954-962-0252
800-962-3383

Alamo Service Company

1450 North Flores Street
San Antonio, Texas 78212
210-227-2450
800-328-2450

Johnstone Supply of Woodside

27-01 Brooklyn Queens Expway
Woodside, New York 11377
718-545-5464
800-431-1143

TECHNICAL SUPPORT CONTACT INFORMATION



F R I E D R I C H

FRIEDRICH AIR CONDITIONING CO.

10001 Reunion Place, Ste. 500, San Antonio, TX 78216
(210) 546-0500 877-599-5665 x 261 FAX (210) 546-0630
Email: tac@friedrich.com
www.friedrich.com

Printed in the U.S.A.

SPECIFICATIONS

ELECTRICAL DATA

TYPE		Cool & heat inverter	
INDOOR UNIT		MW18Y3H	MW24Y3H
OUTDOOR UNIT		MR18Y3H	MR24Y3H
COOLING CAPACITY		18,000 BTU/h 5.28 kW	22,000 BTU/h 6.50 kW
HEATING CAPACITY		21,600 BTU/h 6.30 kW	27,600 BTU/h 8.10 kW
POWER SOURCE		208 V / 230 V	208 V / 230 V
FREQUENCY		60 Hz	60 Hz
RUNNING CURRENT	Cooling	6.3 A	7.9 A
	Heating	8.0 A	10.5 A
INPUT WATTS	Cooling	1.38 kW	1.76 kW
	Heating	1.80 kW	2.38 kW
E.E.R.	Cooling	13.0 BTU/kW 3.83 kW/kW	12.5 BTU/kW 3.69 kW/kW
COP	Heating	12.0 BTU/kW 3.50 kW/kW	11.6 BTU/kW 3.40 kW/kW
MOISTURE REMOVAL		5.9 Pt/h 2.8 L/hr	6.3 Pt/h 3.0 L/hr
AIR CIRCULATION HIGH		541 cfm 920 m ³ /hr	659 cfm 1,120 m ³ /hr
MAXIMUM CURRENT		14.5 A	15.5 A

FAN MOTOR

POWER SOURCE		230 V	230 V
INDOOR UNIT	High speed	1,260 r.p.m.	1,480 r.p.m.
	Middle speed	1,020 r.p.m.	1,220 r.p.m.
	Low speed	900 r.p.m.	1,020 r.p.m.
	Quiet	770 r.p.m.	900 r.p.m.
OUTDOOR UNIT	Cool	620 r.p.m.	800 r.p.m.
	Heat	620 r.p.m.	850 r.p.m.

NOISE LEVEL

INDOOR UNIT	Cool 43 dB / Heat 44 dB	Cool 49 dB / Heat 49 dB
OUTDOOR UNIT	Cool 47 dB / Heat 50 dB	Cool 54 dB / Heat 55 dB

COMPRESSOR AND REFRIGERANT

TYPE		Hermetic type, 6 pole, DC inverter motor, Rotary
DISCRIMINATION		N-TF30ND1A
WEIGHT WITH OIL		34.2 lb 15.5 kg
PRECHARGED REFRIGERANT		4 lb 10 oz 2,100 g
REFRIGERANT TYPE		R410A
FULL CHARGE	Pipe length 66 ft 20 m	4 lb 10 oz 2,100 g
	164 ft 50 m	7 lb 4 oz 3,300 g
ADDITIONAL CHARGE		0.43 oz/ft 40 g/m

DIMENSIONS

INDOOR UNIT	H x W x D	12-5/8 x 39-1/4 x 9 inch	320 x 998 x 228 mm
OUTDOOR UNIT	H x W x D	32-3/4 x 35-3/8 x 13 inch	830 x 900 x 330 mm

WEIGHT

INDOOR UNIT	Shipping / Net	40 lbs / 31 lbs	18 kg / 14 kg
OUTDOOR UNIT	Shipping / Net	150 lbs / 135 lbs	68 kg / 61 kg

DIMENSIONS

INDOOR UNIT

Unit : inch (mm)

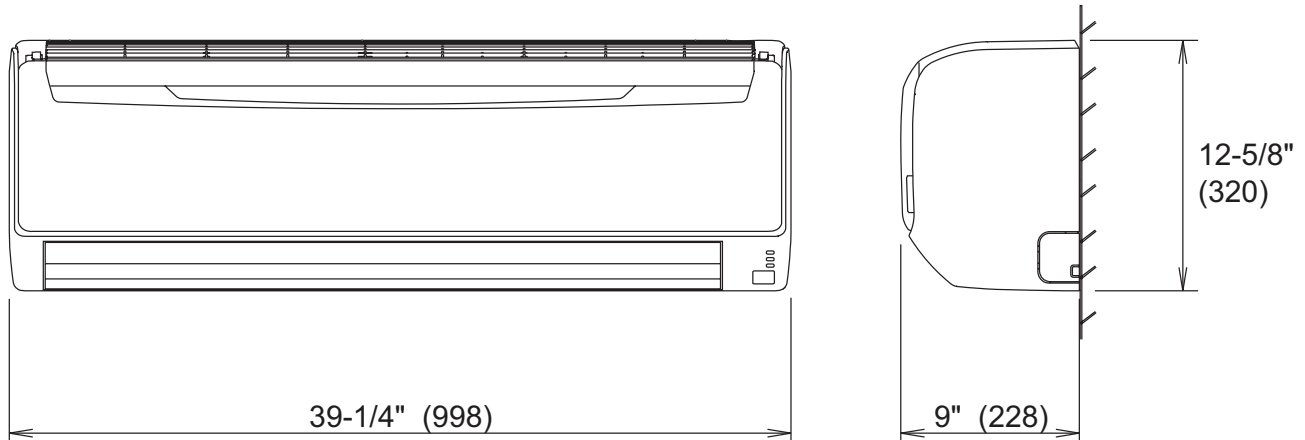

Drain pipe diameter

Inside : 5/8 inch (16 mm)

Outside : 1-3/32 inch (28 mm)

Liquid pipe diameter : 3/8 inch (9.52 mm)

Gas pipe diameter : 5/8 inch (15.88 mm)

OUTDOOR UNIT

Unit : inch (mm)

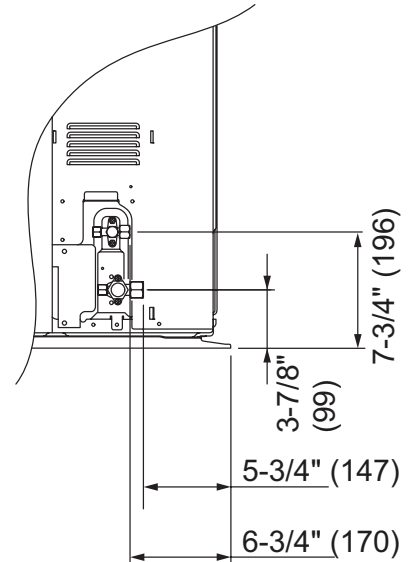
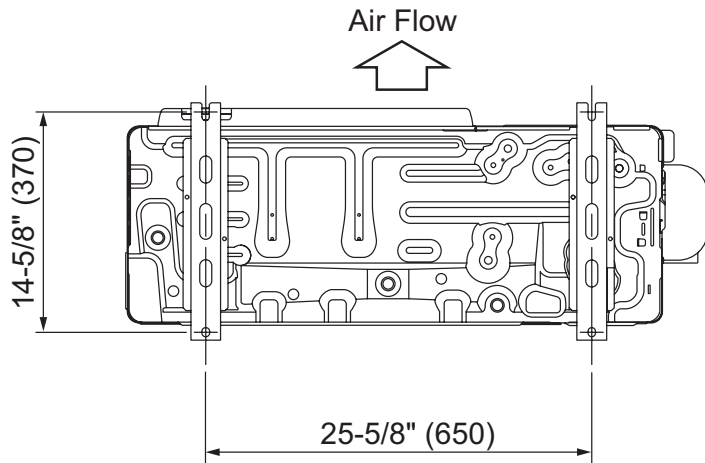
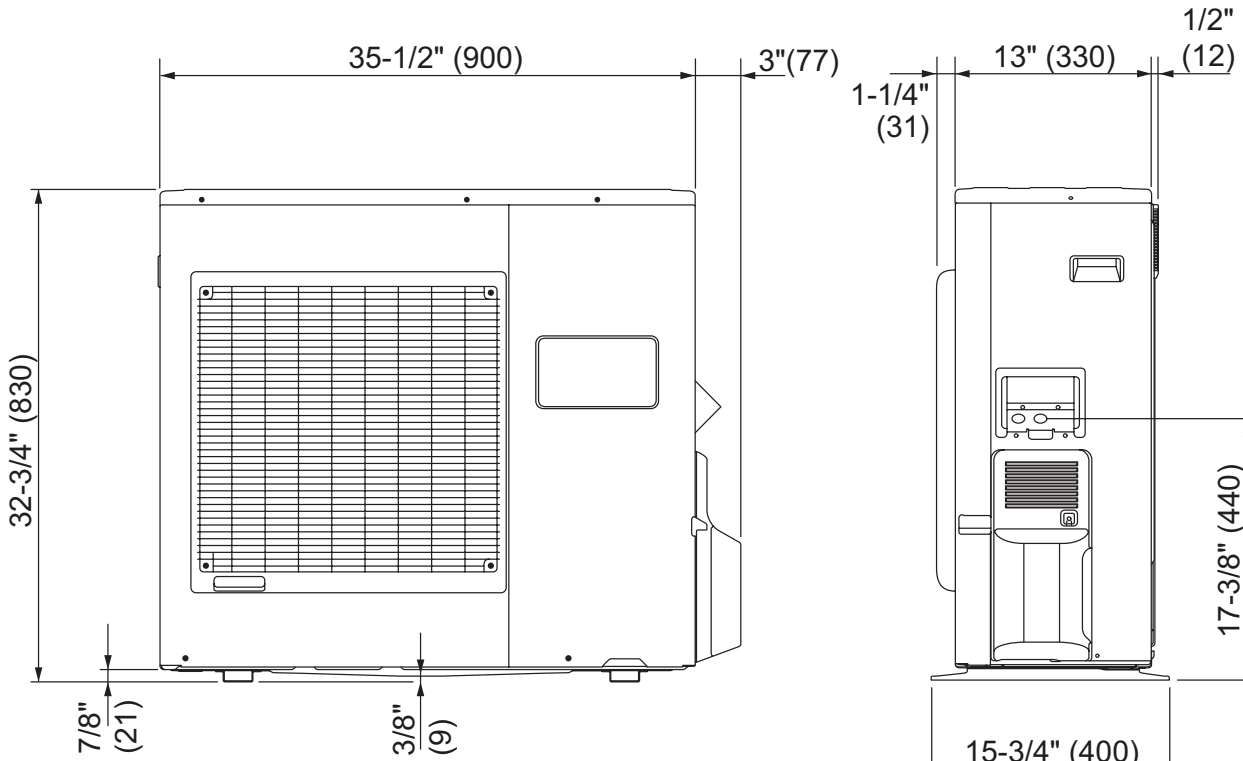
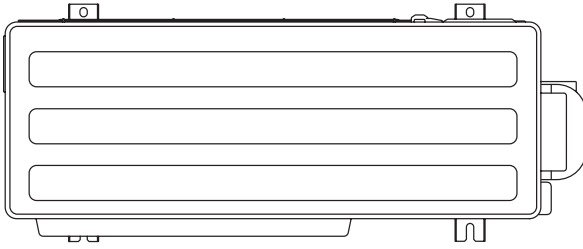

REFRIGERANT SYSTEM DIAGRAM

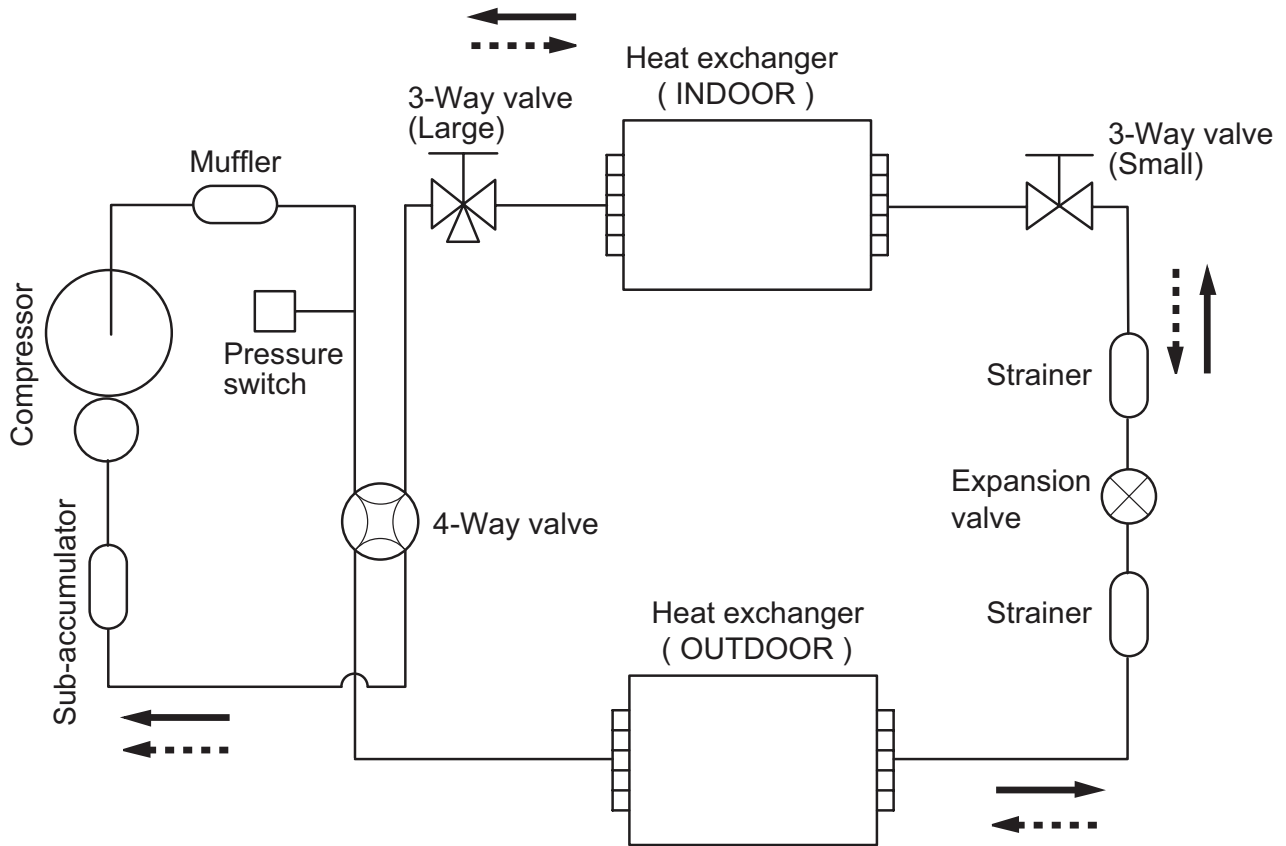

———→ Cooling flow
 - - - -> Heating flow

Refrigerant pipe diameter
 Liquid : 3/8" (9.52 mm)
 Gas : 5/8" (15.88 mm)

CIRCUIT DIAGRAM

MW18Y3H / MR18Y3H

INDOOR UNIT

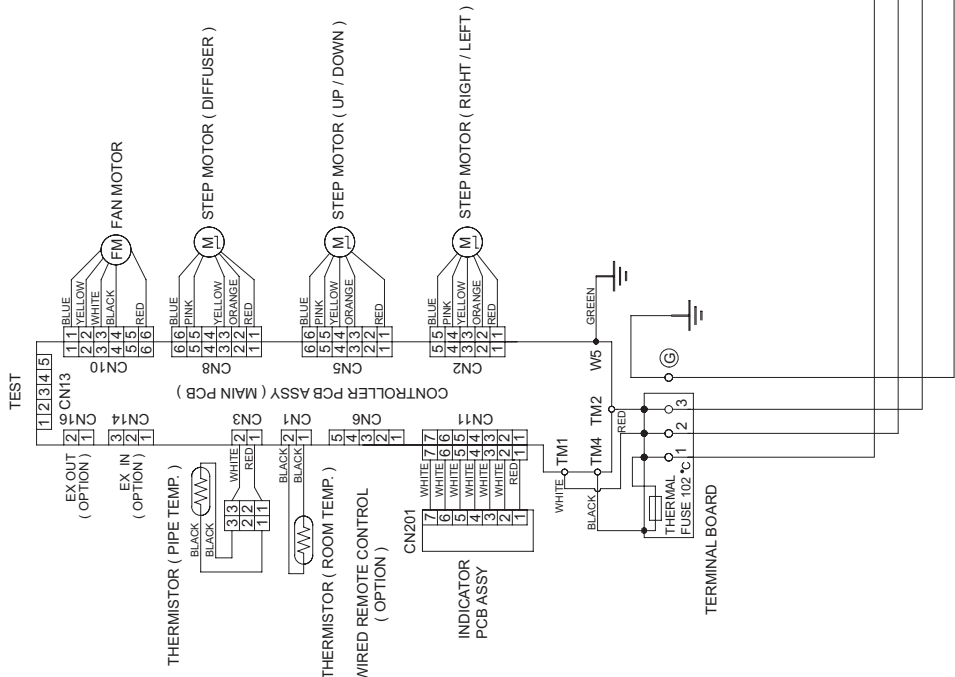

OUTDOOR UNIT

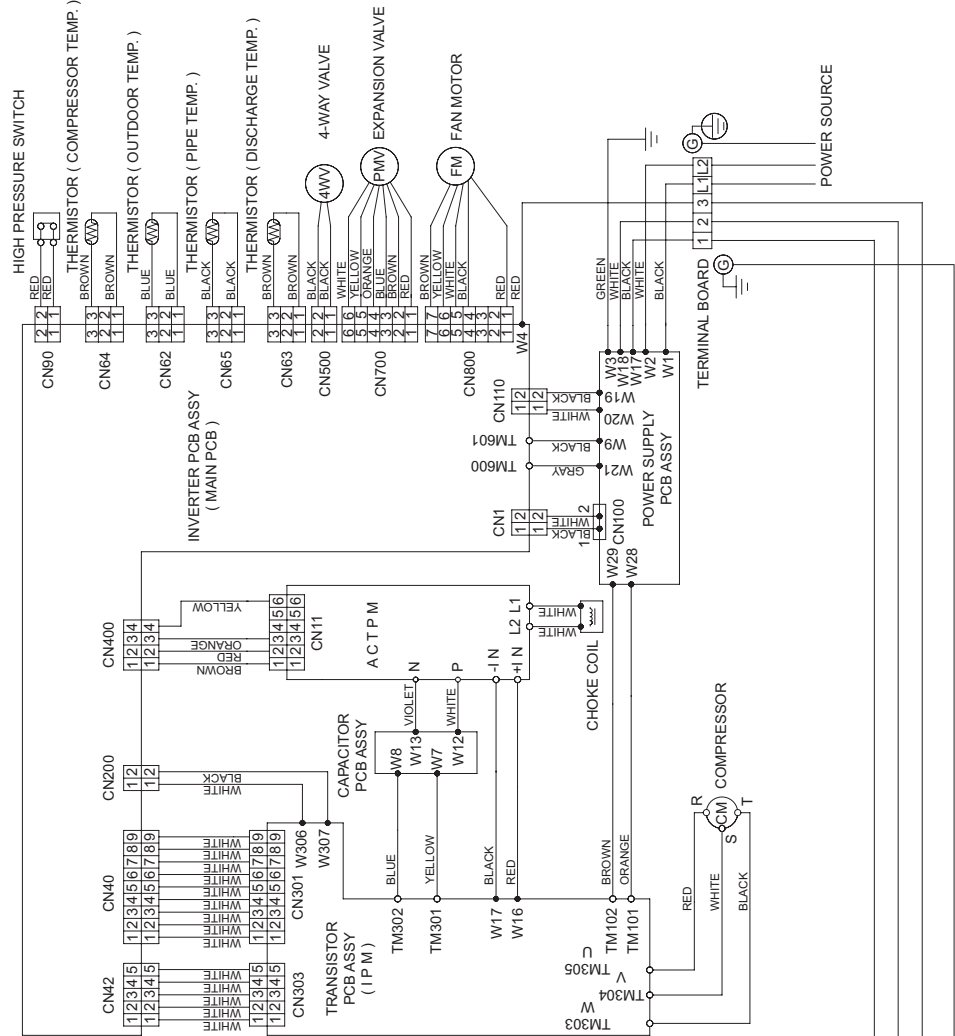

MW24Y3H / MR24Y3H

INDOOR UNIT

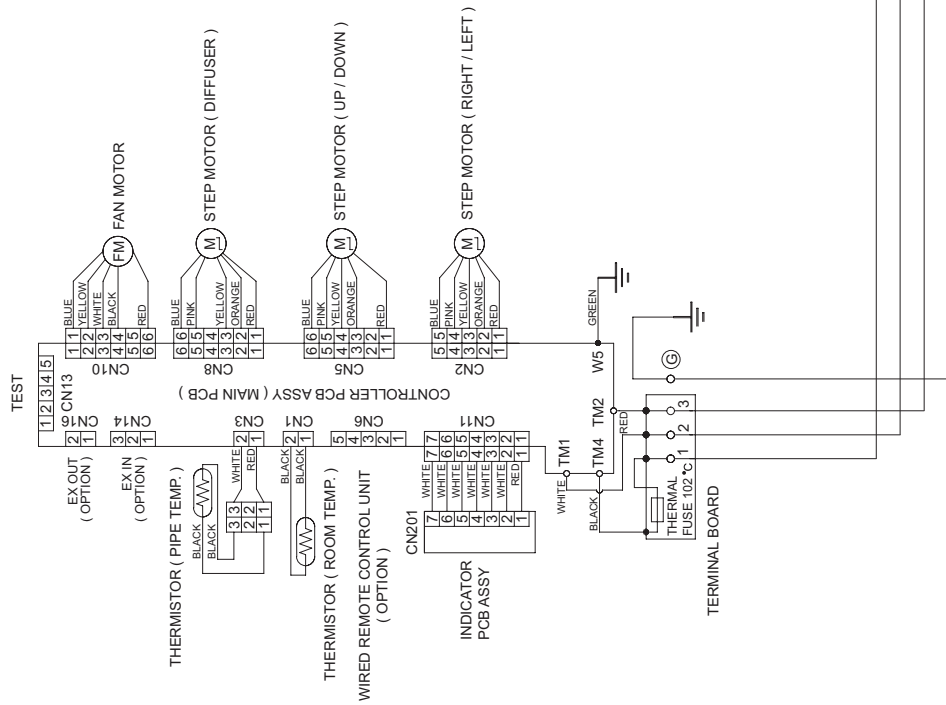

OUTDOOR UNIT

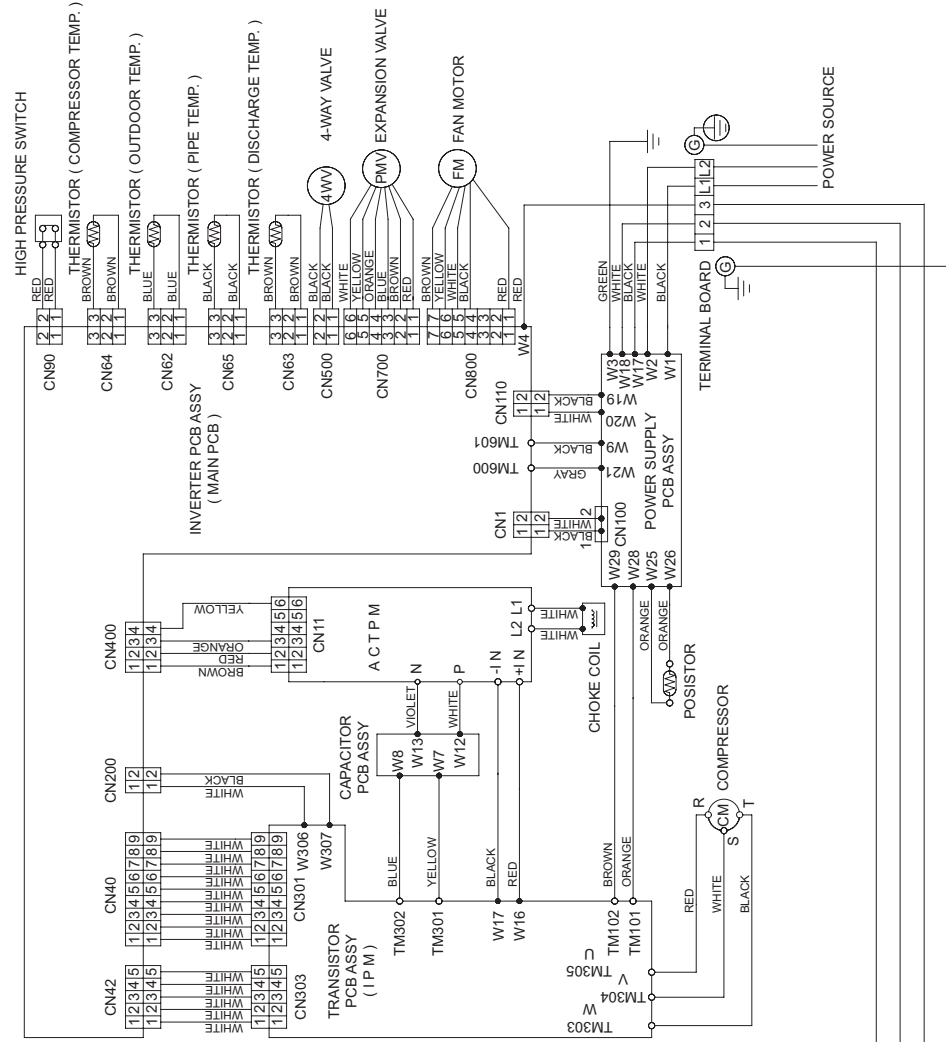

INDOOR PCB CIRCUIT DIAGRAM

CONTROL UNIT

MW18Y3H : EZ-0090HHSE

MW24Y3H : EZ-0090KHSE

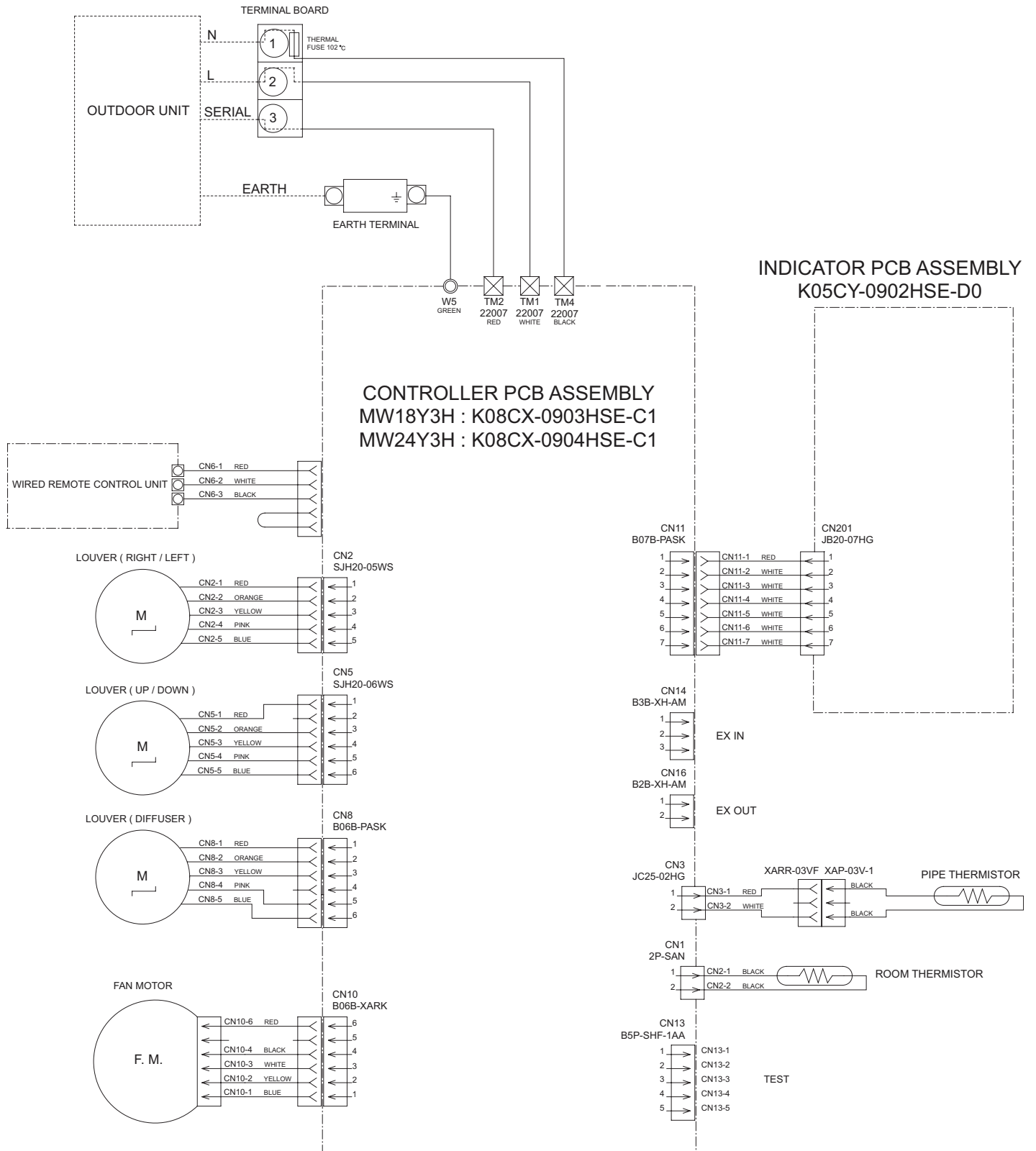

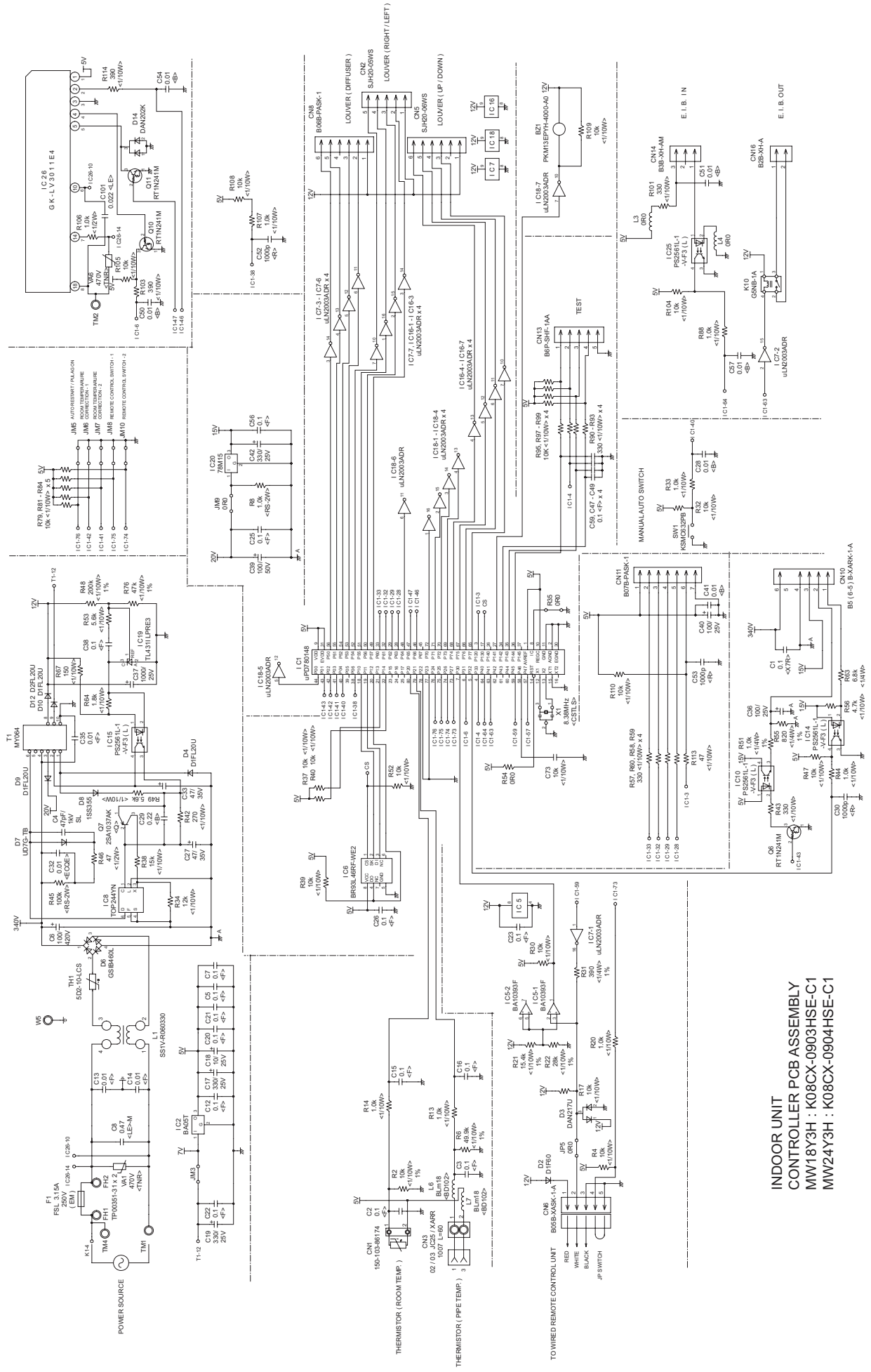

INDOOR UNIT
 CONTROLLER PCB ASSEMBLY
 MW18Y3H : K08CX-0903HSE-C1
 MW24Y3H : K08CX-0904HSE-C1

INDOOR UNIT
 INDICATOR PCB ASSEMBLY
 K05CY-0902HSE-D0

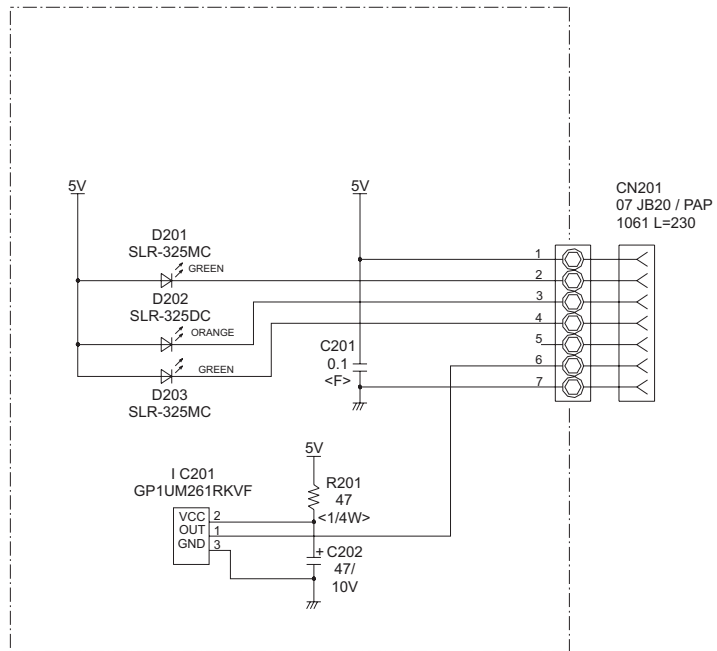

OUTDOOR PCB CIRCUIT DIAGRAM

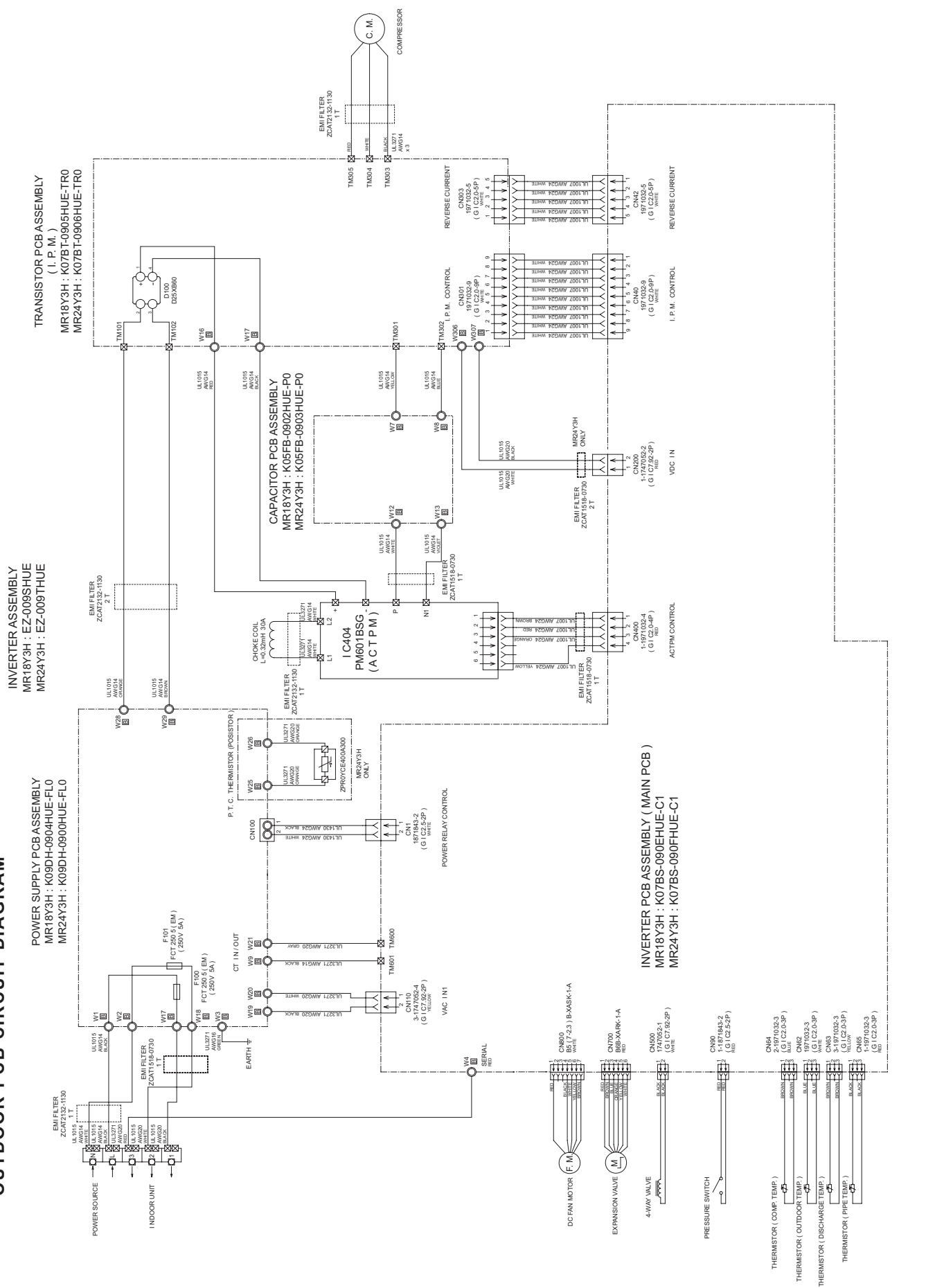

**OUTDOOR UNIT
INVERTER PCB ASSEMBLY (MAIN PCB)
MR18Y3H : K07BS-090EHUE-C1
MR24Y3H : K07BS-090FHUE-C1**

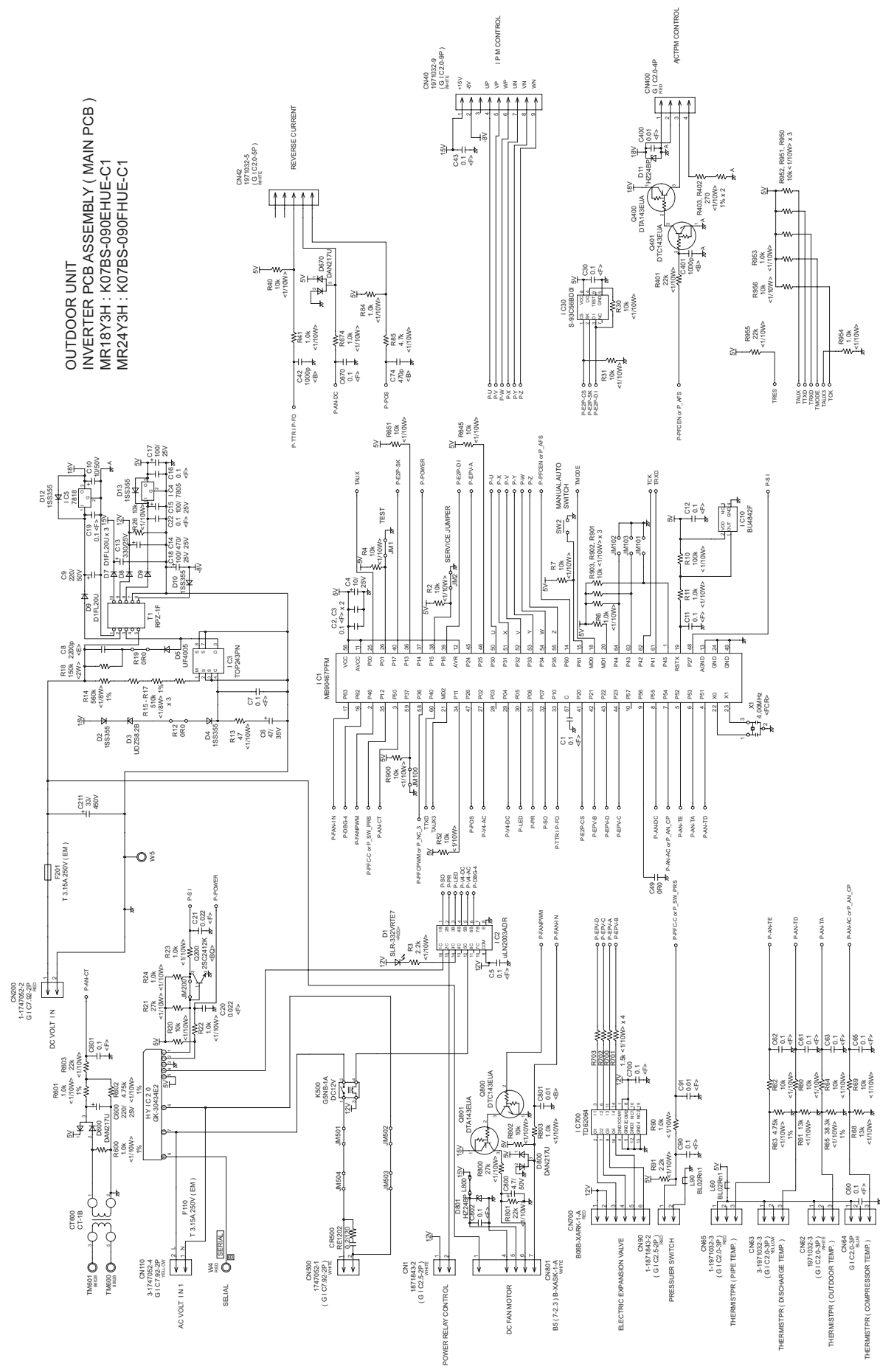

OUTDOOR UNIT
 TRANSISTOR PCB ASSEMBLY (I P M PCB)
 MR18Y3H : K07BT-0905HUE-TR0
 MR24Y3H : K07BT-0906HUE-TR0

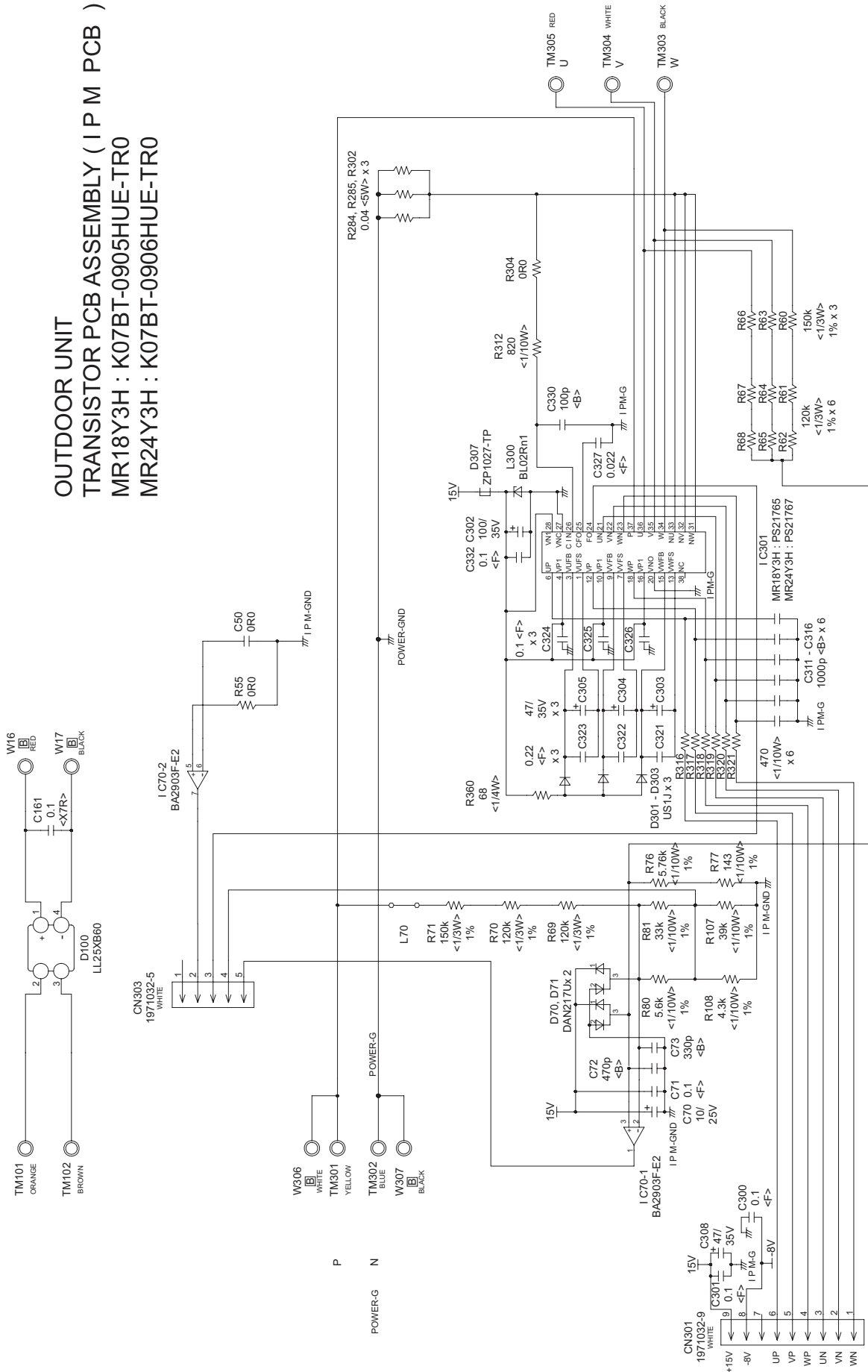

OUTDOOR UNIT
 MR18Y3H
 POWER SUPPLY PCB ASSEMBLY
 K09DH-0904HUE-FLO

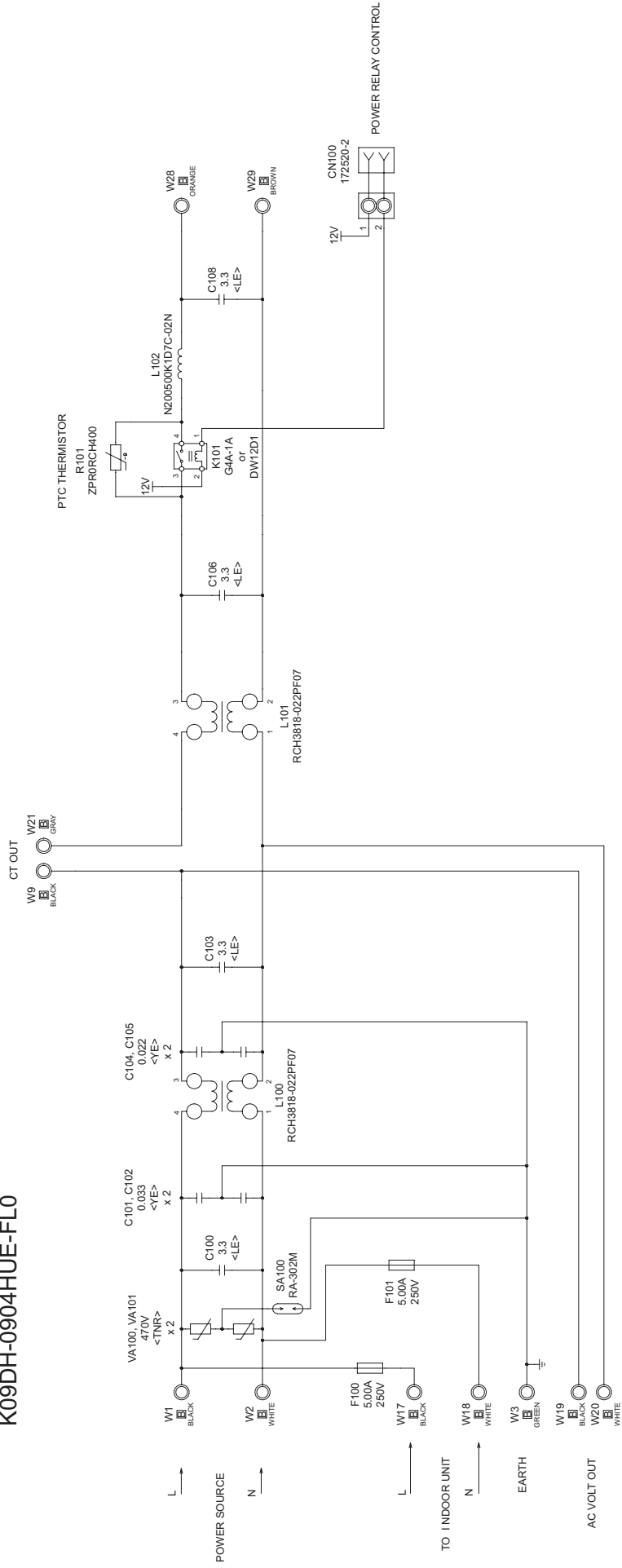

OUTDOOR UNIT
 MR24Y3H
 POWER SUPPLY PCB ASSEMBLY
 K09DH-0900HUE-FLO

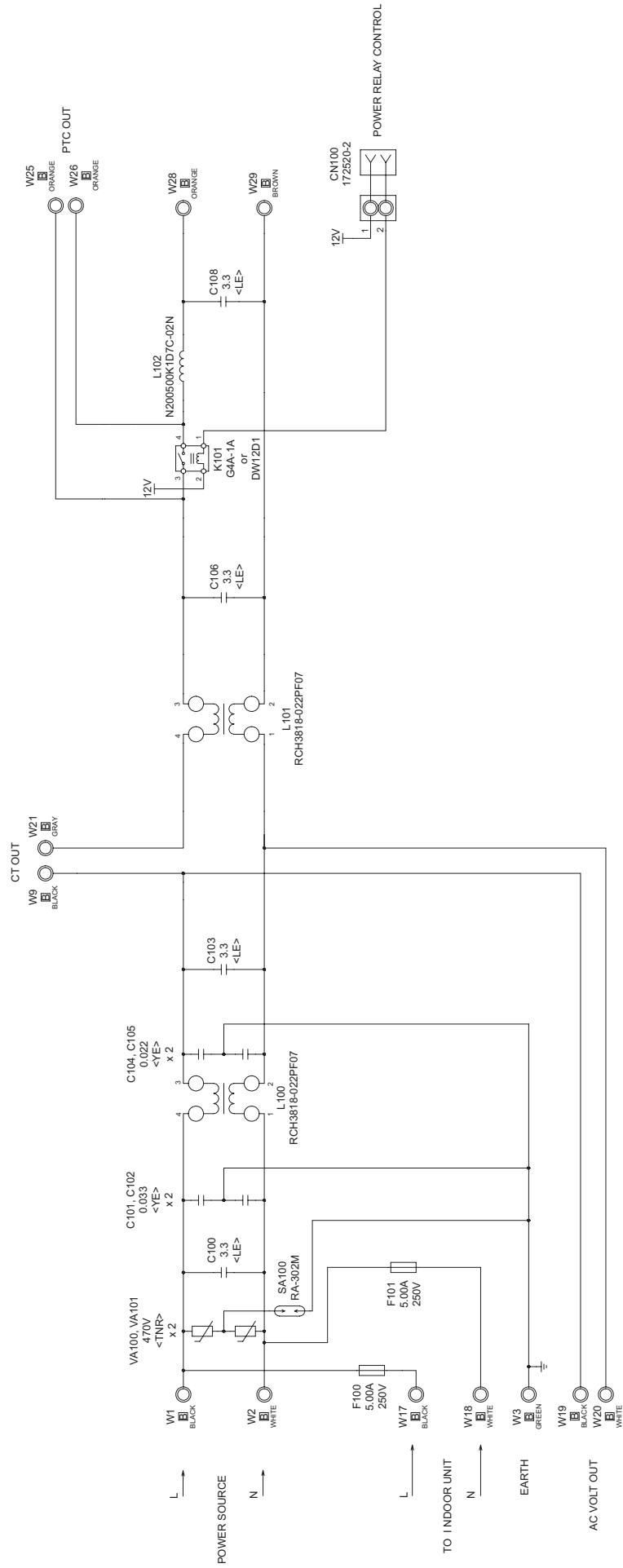

OUTDOOR UNIT
 MR18Y3H
 CAPACITOR PCB ASSEMBLY
 K05FB-0902HUE-P0

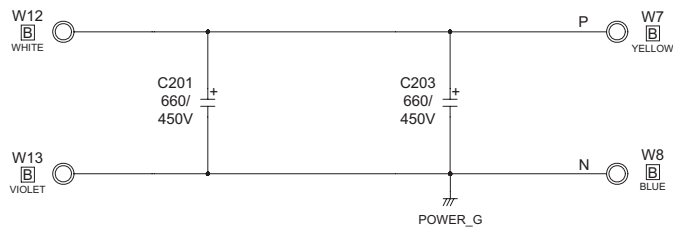

MR24Y3H
 CAPACITOR PCB ASSEMBLY
 K05FB-0903HUE-P0

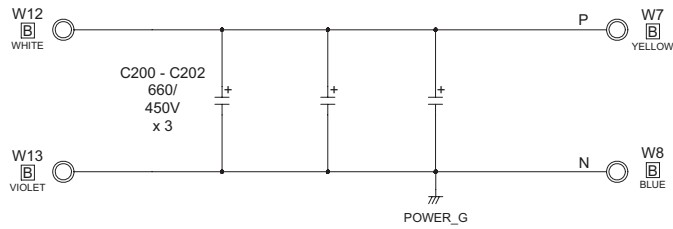

ERROR DETECTION

Error	Display		Error
	Operation LED	Timer LED	
Serial signal error	Normal	2 flash	Serial signal (reverse) error, at operation start up
		3 flash	Serial signal (reverse) error, during operation
		4 flash	Serial signal (forward) error, at operation start up
		5 flash	Serial signal (forward) error, during operation
		8 flash	Wired remote controller error
Indoor unit thermistor error	2 flash	2 flash	Indoor temperature thermistor open / short
		3 flash	Heat exchanger middle thermistor open / short
Outdoor unit thermistor error	3 flash	2 flash	Discharge thermistor open / short
		3 flash	Heat exchanger thermistor open
		4 flash	Outdoor temperature thermistor open / short
		8 flash	Compressor temperature thermistor open / short
Indoor unit control error	4 flash	2 flash	Forced automatic SW welded
		3 flash	Main relay welded
		4 flash	Power interruption error
		7 flash	VDD permanent stop protection
		8 flash	reverse VDD permanent stop protection
Outdoor unit control error	5 flash	2 flash	Current trip error
		3 flash	CT abnormal
		5 flash	Compressor location detection error
		6 flash	Outdoor unit fan drive system abnormal
Indoor fan motor error	6 flash	2 flash	Abnormal lock
		3 flash	Abnormal rotation
Refrigerant cycle error	7 flash	2 flash	Discharge Temperature abnormal
		3 flash	Cooling high pressure abnormal rise
		5 flash	Pressure switch trouble
Optional function error	8 flash	2 flash	Active filter voltage trouble (second time)
		3 flash	Active filter voltage trouble (first time)
		4 flash	PFC circuit error
Model information error	0.1 sec on/off	0.1 sec on/off	Model information error

OUTDOOR UNIT

LED	ERROR
on	Discharge temperature abnormal
0.5 second on / 0.5 second off	IPM overcurrent protection
0.1 second on / 0.1 second off	Thermistor abnormal
2.0 second on / 2.0 second off	CT abnormal
0.1 second on / 2.0 second off	Compressor location abnormal
5.0 second on / 5.0 second off	Fan abnormal

PARTS

INDOOR UNIT

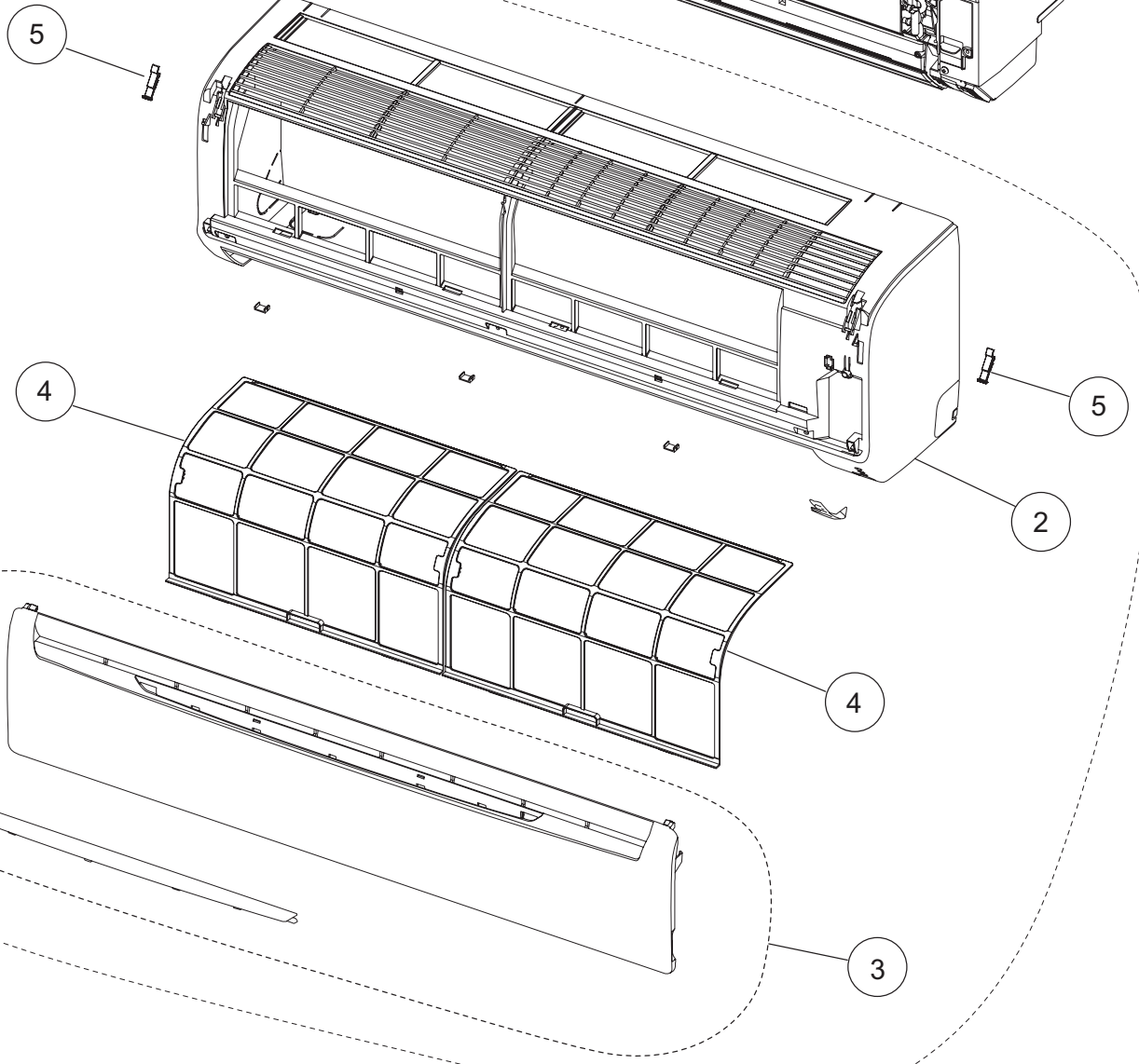
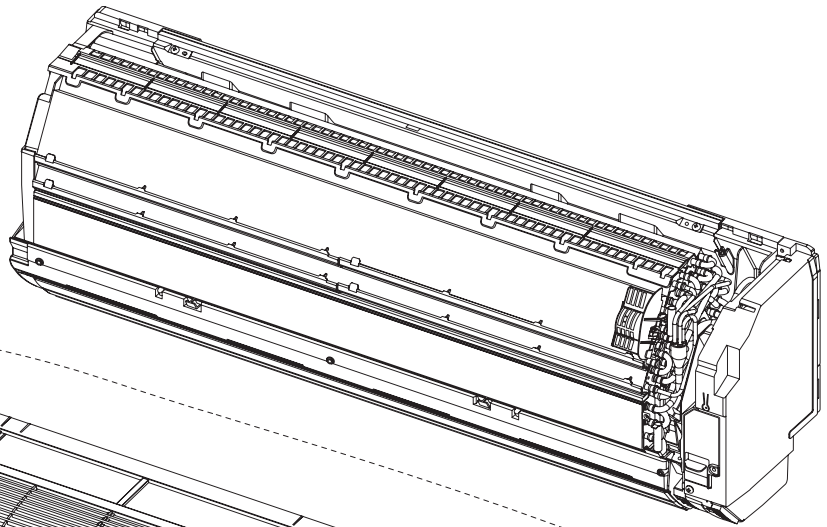

Ref	Description	Part number
1	Front Panel Total Assy	67201282
2	Front Panel	67201791
3	Intake Grille Assy	67201501
4	Air Filter	67201502
5	Clamper Grille	67200936
--	Remote	67201294
--	Remote Holder	67201533

INDOOR UNIT

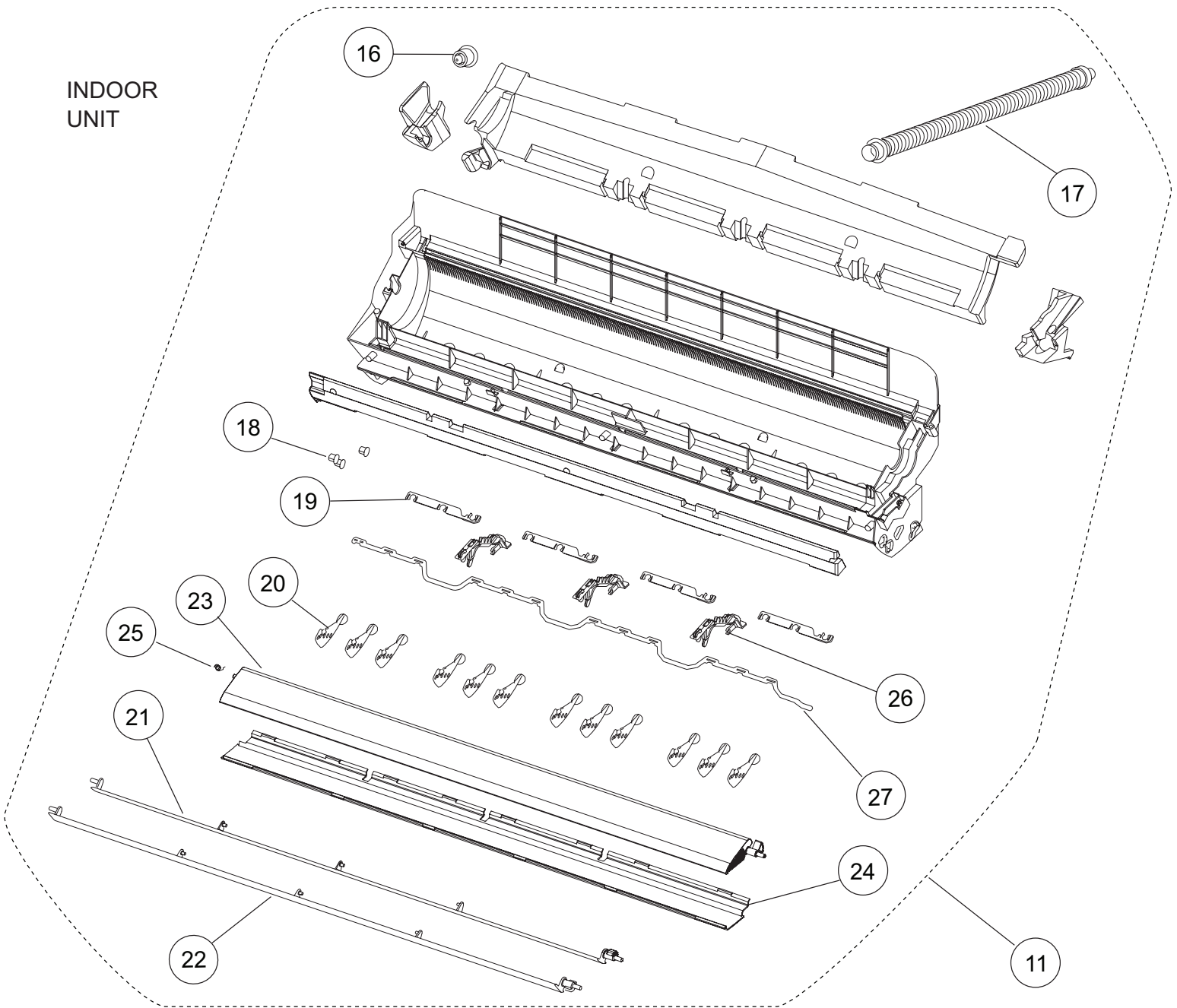

Ref	Description	Part number	Ref	Description	Part number
11	Casing Assy	67201281	21	Louver U	67201565
16	Drain Cap	67201509	22	Louver Z	67201566
17	Drain Hose Assy	67201560	23	Diffuser U	67201562
18	Bush B	67201561	24	Diffuser Z	67201563
19	Spacer B	67201507	25	Spring C	67201564
20	R and L Louver	67201506	26	Pillar A	67201277
			27	Joint B	67201274
			--	Fan Guard	67201271
			--	Fan Guard Holder Right	67201289
			--	Fan Guard Holder Left	67201290

INDOOR UNIT

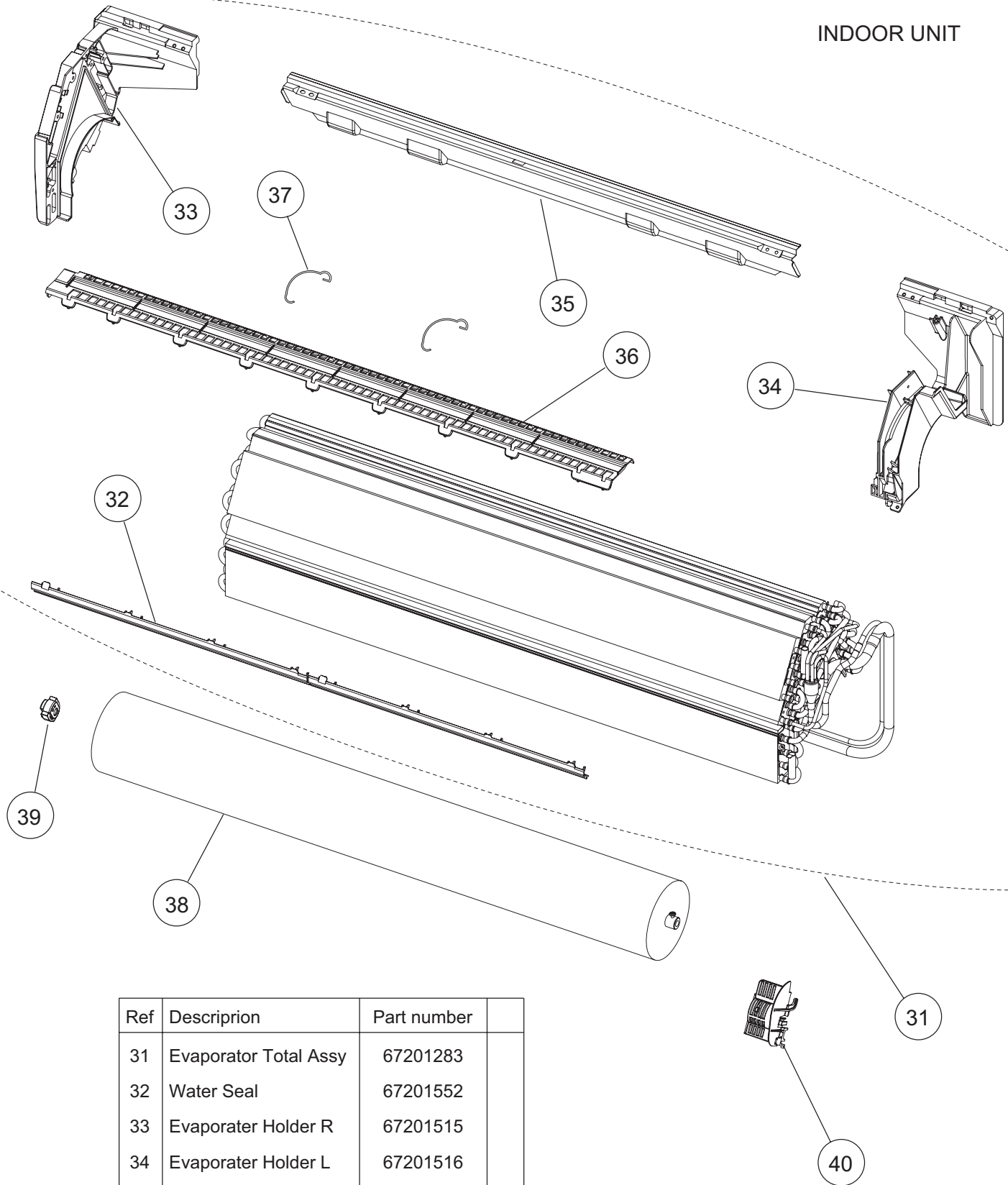

Ref	Description	Part number
31	Evaporator Total Assy	67201283
32	Water Seal	67201552
33	Evaporater Holder R	67201515
34	Evaporater Holder L	67201516
35	Rear Bracket	67201553
36	Filter Guide	67201554
37	Filter Guard	67201555
38	Crossflow Fan Assy	67201504
39	Bearing C Assy	67200922
40	Room Therimistor Holder	67201280

INDOOR UNIT

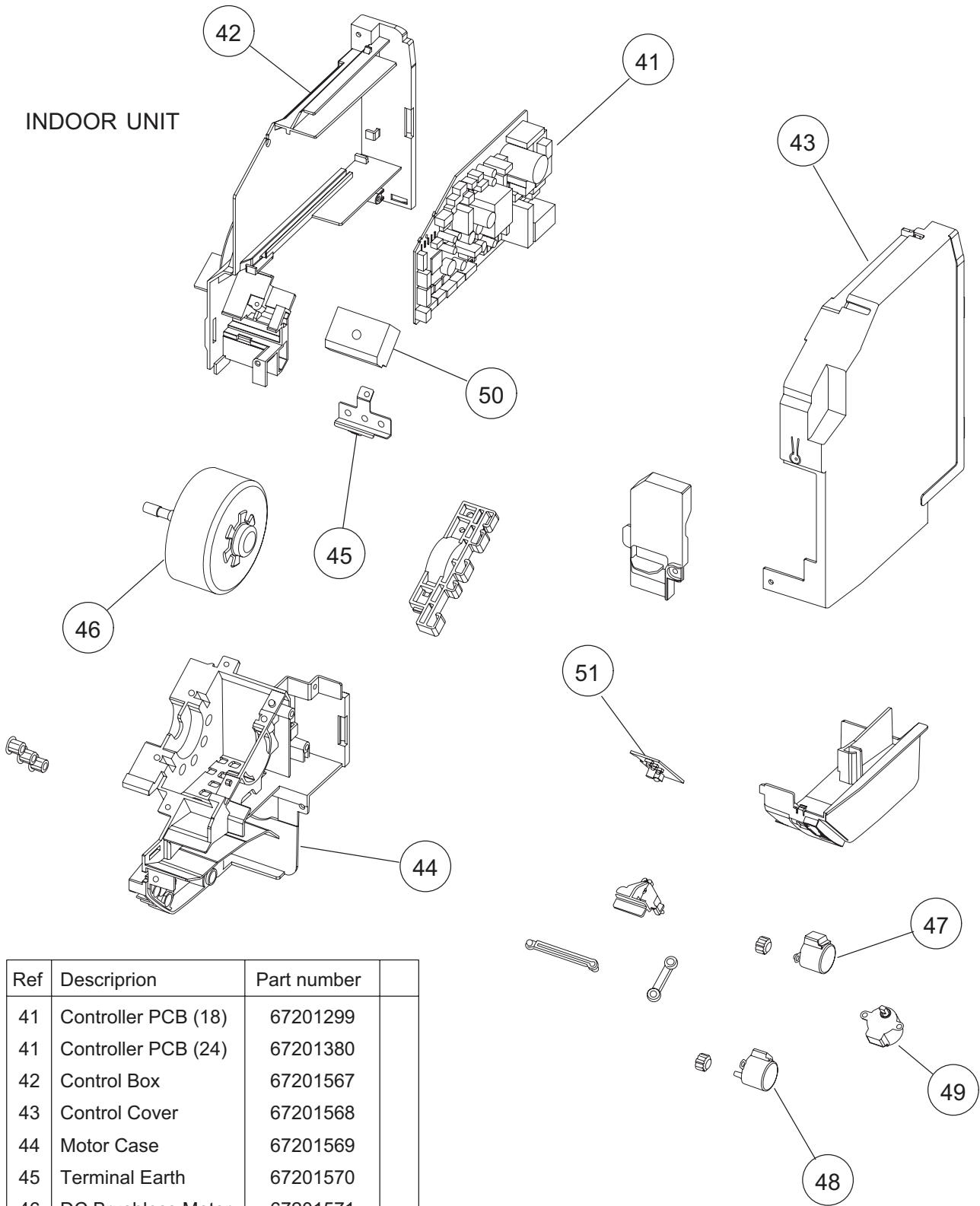

Ref	Description	Part number
41	Controller PCB (18)	67201299
41	Controller PCB (24)	67201380
42	Control Box	67201567
43	Control Cover	67201568
44	Motor Case	67201569
45	Terminal Earth	67201570
46	DC Brushless Motor	67201571
47	Motor, Step	67201526
48	Motor, Step	67201527
49	Motor, Step	67201528
50	Terminal	67201381
51	Indicator PCB Assy	67201298
--	Pipe Thermistor	67201574

Controller PCB includes a room thermistor.

PARTS

OUTDOOR UNIT

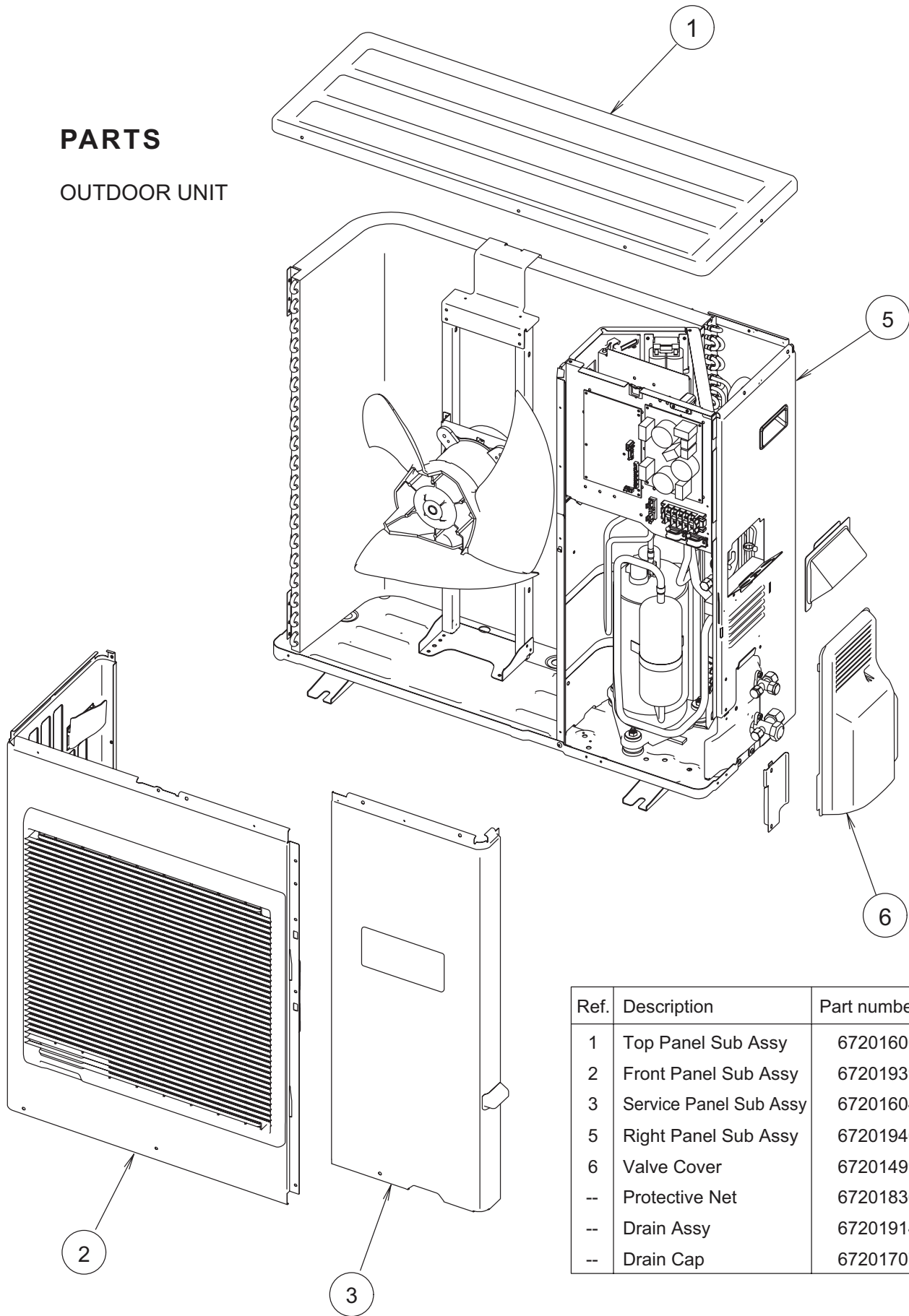

Ref.	Description	Part number
1	Top Panel Sub Assy	67201600
2	Front Panel Sub Assy	67201939
3	Service Panel Sub Assy	67201604
5	Right Panel Sub Assy	67201940
6	Valve Cover	67201499
--	Protective Net	67201836
--	Drain Assy	67201914
--	Drain Cap	67201707

OUTDOOR UNIT

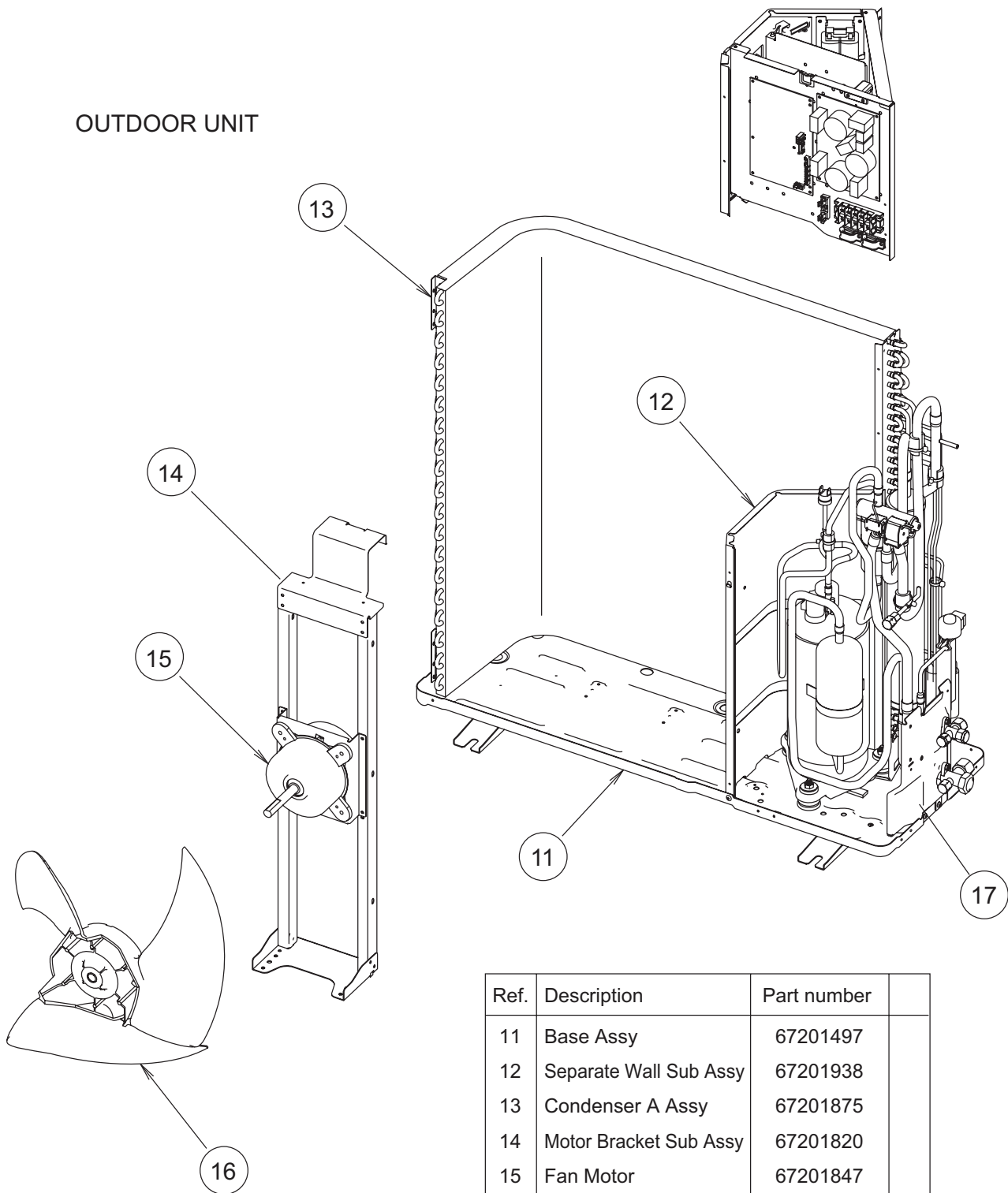

Ref.	Description	Part number
11	Base Assy	67201497
12	Separate Wall Sub Assy	67201938
13	Condenser A Assy	67201875
14	Motor Bracket Sub Assy	67201820
15	Fan Motor	67201847
16	Propeller Fan Assy	67201607
17	Valve Plate	67201496

OUTDOOR UNIT

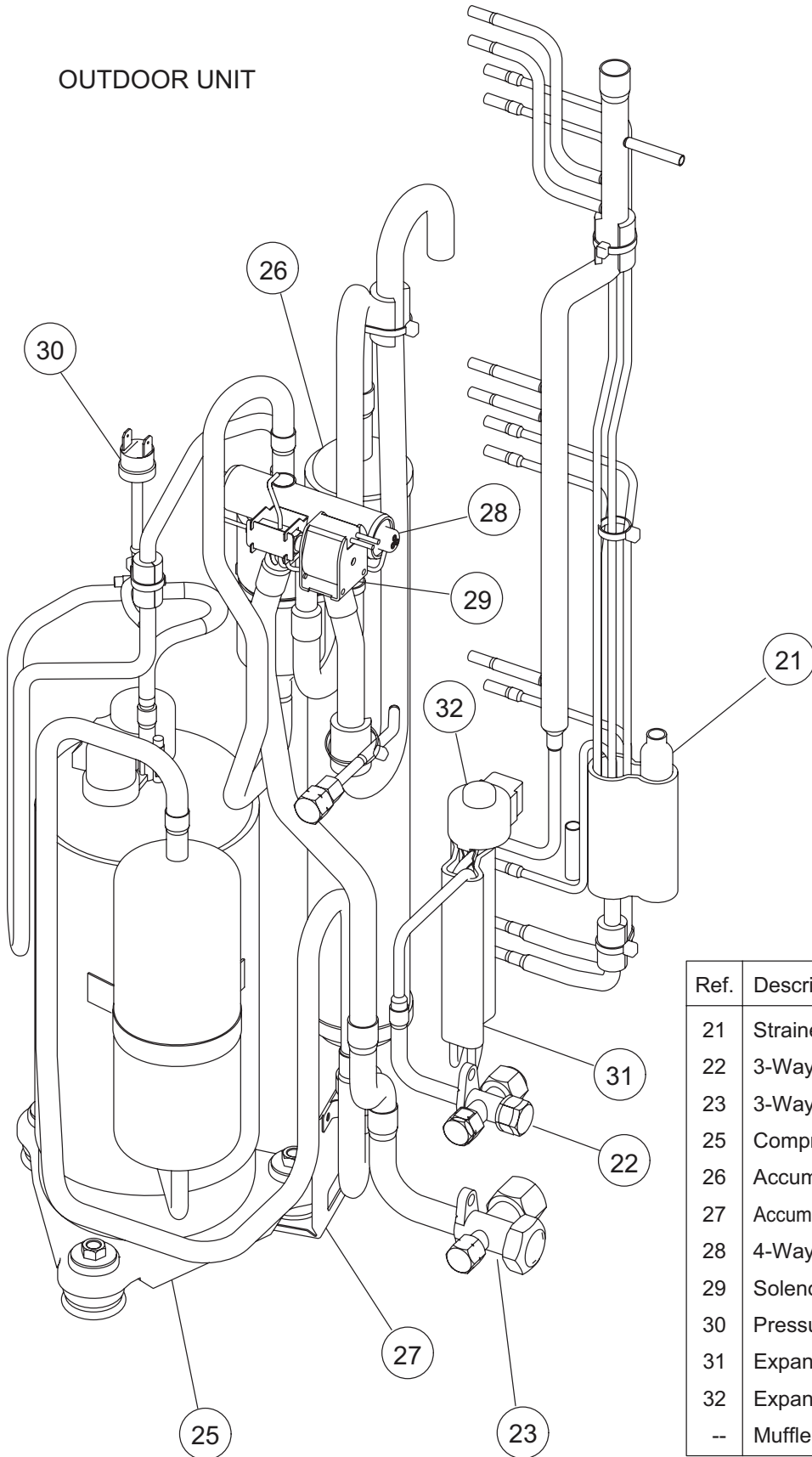

Ref.	Description	Part number
21	Strainer Assy	67201611
22	3-Way Valve Sub Assy	67201837
23	3-Way Valve Assy	67201876
25	Compressor Sub Assy	67201867
26	Accumulator	67201618
27	Accumulator Support Assy	67201483
28	4-Way Valve	67201629
29	Solenoid	67201874
30	Pressure Switch	67201621
31	Expansion Valve Assy	67201488
32	Expansion Valve Coil	67201422
--	Muffler	67201792

OUTDOOR UNIT

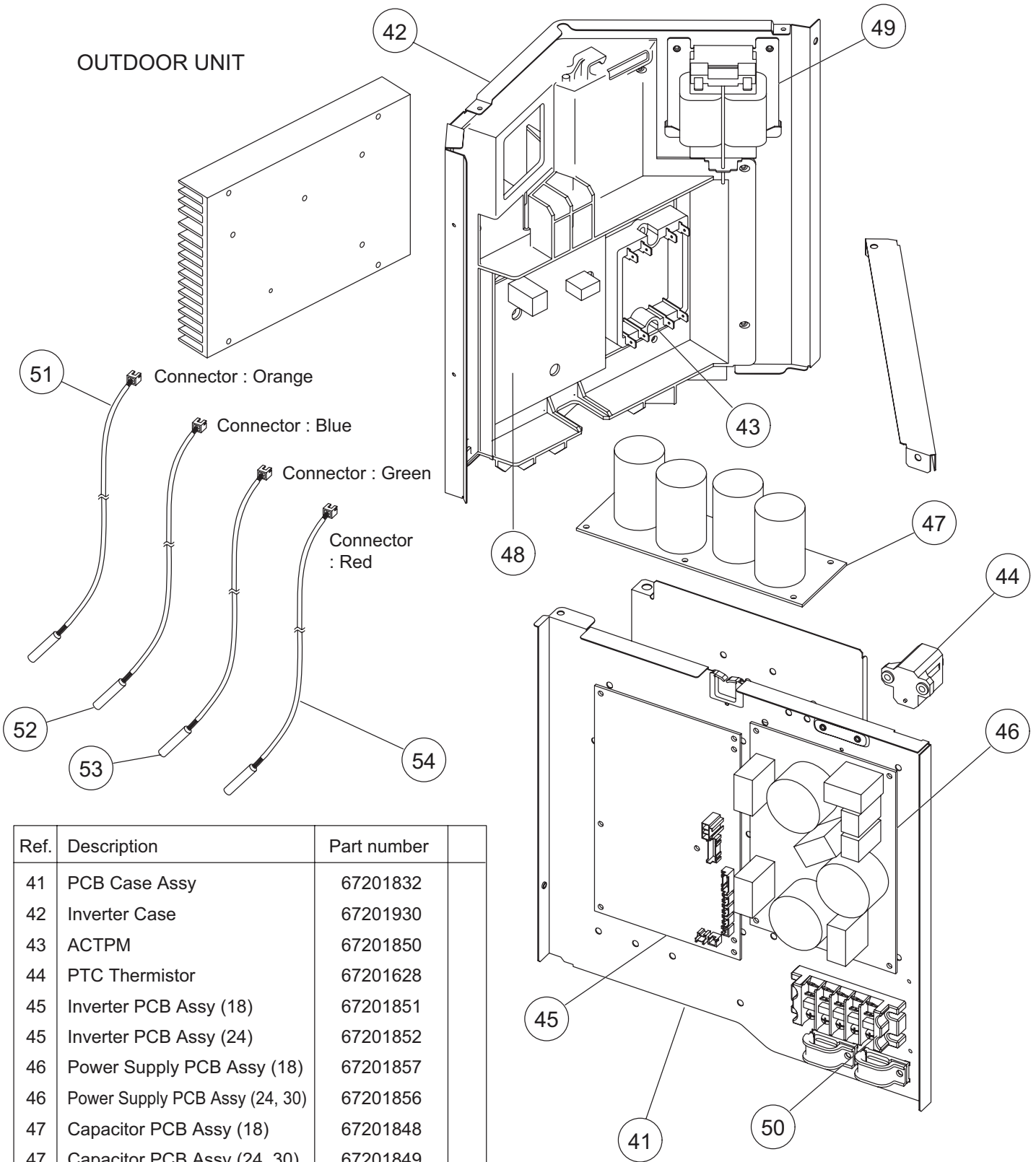

Ref.	Description	Part number
41	PCB Case Assy	67201832
42	Inverter Case	67201930
43	ACTPM	67201850
44	PTC Thermistor	67201628
45	Inverter PCB Assy (18)	67201851
45	Inverter PCB Assy (24)	67201852
46	Power Supply PCB Assy (18)	67201857
46	Power Supply PCB Assy (24, 30)	67201856
47	Capacitor PCB Assy (18)	67201848
47	Capacitor PCB Assy (24, 30)	67201849
48	Transistor PCB Assy (18)	67201853
48	Transistor PCB Assy (24, 30)	67201854
49	Choke Coil	67201868
50	Terminal	67201908
51	Discharge Thermistor	67201869
52	Outdoor Thermistor	67201871
53	Compressor Thermistor	67201872
54	Heat Exchanger Thermistor	67201031



F R I E D R I C H

FRIEDRICH AIR CONDITIONING CO.

10001 Reunion Place, Ste. 500, San Antonio, TX 78216
(210) 546-0500 877-599-5665 x 261 FAX (210) 546-0630
Email: tac@friedrich.com
www.friedrich.com

Printed in the U.S.A.