

WOODS BRUSHBULL™ ROTARY CUTTER

BB48X

BB60X

BB72X

BB84X

Serial Number 1159929 and After

Includes Service and Parts Information for Serial Number 1159928 & Prior

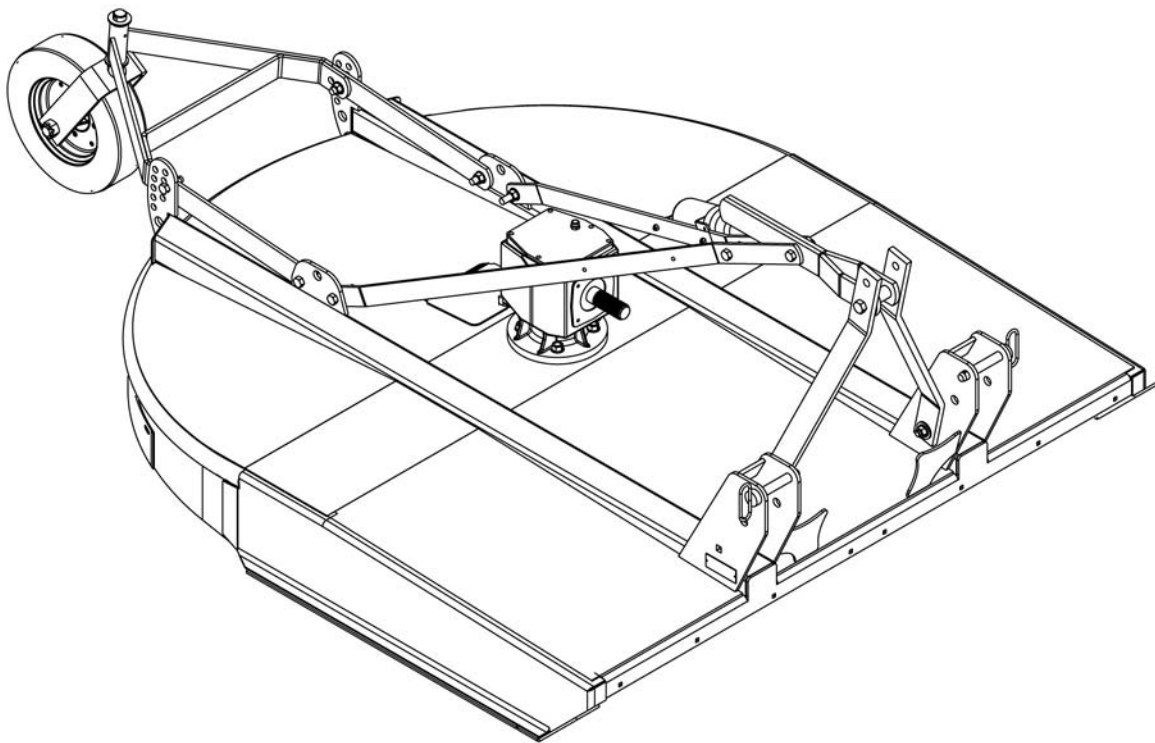

MAN0632
(Rev. 4/20/2011)

WOODS®

OPERATOR'S MANUAL

TO THE DEALER:

Assembly and proper installation of this product is the responsibility of the Woods® dealer. Read manual instructions and safety rules. Make sure all items on the Dealer's Pre-Delivery and Delivery Check Lists in the Operator's Manual are completed before releasing equipment to the owner.

The dealer must complete the online Product Registration form at the Woods Dealer Website which certifies that all Dealer Check List items have been completed. Please contact your dealer to complete this form. Dealers can register all Woods product at dealer.WoodsEquipment.com under Product Registration.

Failure to register the product does not diminish customer's warranty rights.

TO THE OWNER:

Read this manual before operating your Woods equipment. The information presented will prepare you to do a better and safer job. Keep this manual handy for ready reference. Require all operators to read this manual carefully and become acquainted with all adjustment and operating procedures before attempting to operate. Replacement manuals can be obtained from your dealer. To locate your nearest dealer, check the Dealer Locator at www.WoodsEquipment.com, or in the United States and Canada call 1-800-319-6637.

The equipment you have purchased has been carefully engineered and manufactured to provide dependable and satisfactory use. Like all mechanical products, it will require cleaning and upkeep. Lubricate the unit as specified. Observe all safety information in this manual and safety decals on the equipment.

For service, your authorized Woods dealer has trained mechanics, genuine Woods service parts, and the necessary tools and equipment to handle all your needs.

Use only genuine Woods service parts. Substitute parts will void the warranty and may not meet standards required for safe and satisfactory operation. Record the model number and serial number of your equipment in the spaces provided:

Model: _____ **Date of Purchase:** _____

Serial Number: (see Safety Decal section for location) _____

Provide this information to your dealer to obtain correct repair parts.

Throughout this manual, the term **NOTICE** is used to indicate that failure to observe can cause damage to equipment. The terms **CAUTION**, **WARNING**, and **DANGER** are used in conjunction with the Safety-Alert Symbol (a triangle with an exclamation mark) to indicate the degree of hazard for items of personal safety.



This is the safety alert symbol. It is used to alert you to potential personal injury hazards. Obey all safety messages that follow this symbol to avoid possible injury or death.



Indicates a hazardous situation which, if not avoided, will result in death or serious injury.



Indicates a hazardous situation which, if not avoided, could result in death or serious injury.



Indicates a hazardous situation which, if not avoided, could result in minor or moderate injury.

**IMPORTANT
or NOTICE**

Is used to address practices not related to personal injury.

NOTE

Indicates helpful information.

WOODS®

ALITEC™
BMP®
CENTRAL FABRICATORS®
GANNON®
GILL®
WAIN-ROY®
WOODS®

2 Introduction

Gen'l (Rev. 3/5/2010)

TABLE OF CONTENTS

INTRODUCTION.....	2
SPECIFICATIONS.....	4
GENERAL INFORMATION.....	4
SAFETY VIDEO ORDER FORM.....	5
SAFETY RULES.....	7-9
SAFETY DECALS.....	10-11
OPERATION.....	12
OWNER SERVICE.....	18
TROUBLE SHOOTING.....	23
DEALER SERVICE.....	24
DEALER CHECK LISTS.....	34
ASSEMBLY INSTRUCTIONS.....	36
INDEX TO PARTS LISTS.....	43
BOLT TORQUE CHART.....	56
BOLT SIZE CHART & ABBREVIATIONS.....	57
INDEX.....	58
PRODUCT WARRANTY.....	INSIDE BACK COVER
REPLACEMENT PARTS WARRANTY.....	BACK COVER

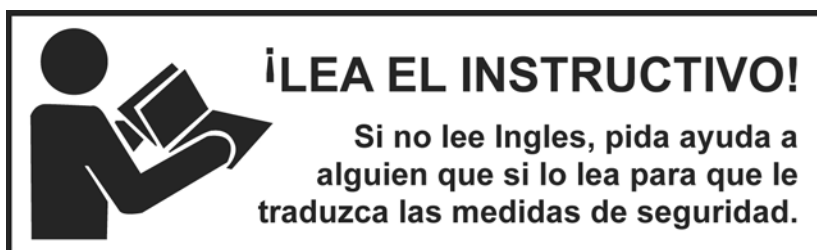

This Operator's Manual should be regarded as part of the machine. Suppliers of both new and second-hand machines must make sure that this manual is provided with the machine.

SPECIFICATIONS

3-Point Hitch:	BB48X, BB60X, BB72X.....	Category 1
	BB84X.....	Category 1 & 2
Cutting Height.....		1" - 9"
Blade Spindle.....		1
Number of Blades.....		2
Blades.....		Heat Treated Alloy Steel
Blade Rotation.....		CCW
Tractor PTO RPM.....		540
Universal Drive.....		Category 3 or 4
Side Frame Thickness.....		10 Ga or 11 Ga
Tailwheel.....		4" x 16"

	<u>BB48X</u>	<u>BB60X</u>	<u>BB72X</u>	<u>BB84X</u>
Cutting Width	48"	60"	72"	84"
Overall Width	53.5"	65.5"	77.5"	89.5"
Weight (Approximate)	456 lbs	554 lbs	702 lbs	1000 lbs
Blade Speed (Feet per minute)	13,000	14,335	14,963	14,963
Gearbox	1:1.92	1:1.69	1:1.47	1:1.26
Recommended Maximum Tractor HP	15 - 50	25 - 50	30 - 75	35 - 90

GENERAL INFORMATION

WARNING

■ **Some illustrations in this manual show the equipment with safety shields removed to provide a better view. This equipment should never be operated with any necessary safety shielding removed.**

The purpose of this manual is to assist you in operating and maintaining your cutter. Read it carefully. It furnishes information and instructions that will help you achieve years of dependable performance. These instructions have been compiled from extensive field experience and engineering data. Some information may be general in nature due to unknown and varying

operating conditions. However, through experience and these instructions, you should be able to develop procedures suitable to your particular situation.

The illustrations and data used in this manual were current at the time of printing, but due to possible inline production changes, your machine may vary slightly in detail. We reserve the right to redesign and change the machines as may be necessary without notification.

Throughout this manual, references are made to right and left directions. These are determined by standing behind the equipment, facing the direction of forward travel. Blade rotation is counterclockwise as viewed from the top of the cutter.

BE SAFE!

BE ALERT!

BE ALIVE!

BE TRAINED

Before Operating Mowers!



ASSOCIATION OF
EQUIPMENT
MANUFACTURERS

*Safety Training
Does Make a Difference.*

Free Mower Safety Video

Fill out and return the order form and we will send you a FREE VHS or DVD video outlining ***Industrial and Agricultural Mower Safety Practices***. The 22 minute video, developed in cooperation with AEM (Association of Equipment Manufacturers), reinforces the proper procedures to follow while operating your mowing equipment. The video does not replace the information contained in the Operator's Manual, so please review this manual thoroughly before operating your new mowing equipment.

Also, available from the Association of Equipment Manufacturers:

A large variety of training materials (ideal for groups) are available for a nominal charge from AEM. Following is a partial list:

- **Training Package for Rotary Mowers/Cutters-English**
Contains: DVD & VHS (English)
 Guidebook for Rotary Mowers/Cutters (English)
 AEM Industrial/Agricultural Mower Safety Manual (English)
 AEM Agricultural Tractor Safety Manual (English)

- **Training Package for Rotary Mowers/Cutters-English/Spanish**
Contains: DVD & VHS (English/Spanish)
 Guidebook for Rotary Mowers/Cutters (English/Spanish)
 AEM Industrial/Agricultural Mower Safety Manual (English/Spanish)
 AEM Agricultural Tractor Safety Manual (English/Spanish)

AEM training packages are available through:

AEM at: www.aem.org

or

Universal Lithographers, Inc.

Email: aem@ulilitho.com

800-369-2310 tel

866-541-1668 fax



Free Mower/Cutter Safety Video Order Form

- Please send me (Select one)
- VHS** Format - VHS01052 Safety Video
- DVD** Format - DVD01052 Safety Video

Name: _____ Phone: _____

Address: _____

Mower/Cutter Model: _____ Serial #: _____

Send to: ATTENTION: DEALER SERVICES
 WOODS EQUIPMENT COMPANY
 PO BOX 1000
 OREGON IL 61061-1000
 USA

SAFETY RULES



ATTENTION! BECOME ALERT! YOUR SAFETY IS INVOLVED!



Safety is a primary concern in the design and manufacture of our products. Unfortunately, our efforts to provide safe equipment can be wiped out by an operator's single careless act.

In addition to the design and configuration of equipment, hazard control and accident prevention are dependent upon the awareness, concern, judgement, and proper training of personnel involved in the operation, transport, maintenance, and storage of equipment.

It has been said, "The best safety device is an informed, careful operator." We ask you to be that kind of operator.

TRAINING

■ **Safety instructions are important! Read all attachment and power unit manuals; follow all safety rules and safety decal information. (Replacement manuals and safety decals are available from your dealer. To locate your nearest dealer, check the Dealer Locator at www.WoodsEquipment.com, or in the United States and Canada call 1-800-319-6637.) Failure to follow instructions or safety rules can result in serious injury or death.**

■ **If you do not understand any part of this manual and need assistance, see your dealer.**

■ **Know your controls and how to stop engine and attachment quickly in an emergency.**

■ **Operators must be instructed in and be capable of the safe operation of the equipment, its attachments, and all controls. Do not allow anyone to operate this equipment without proper instructions.**

■ **Never allow children or untrained persons to operate equipment.**

PREPARATION

■ **Check that all hardware is properly installed. Always tighten to torque chart specifications unless instructed otherwise in this manual.**

■ **Always wear relatively tight and belted clothing to avoid getting caught in moving parts. Wear sturdy, rough-soled work shoes and protective equipment for eyes, hair, hands, hearing, and head; and respirator or filter mask where appropriate.**

■ **Make sure attachment is properly secured, adjusted, and in good operating condition.**

■ **Make sure spring-activated locking pin or collar slides freely and is seated firmly in tractor PTO spline groove.**

■ **Before starting power unit, check all equipment driveline guards for damage. Replace any damaged guards. Make sure all guards rotate freely on all drivelines. If guards do not rotate freely on drivelines, repair and replace bearings before putting equipment into service.**

■ **Power unit must be equipped with ROPS or ROPS cab and seat belt. Keep seat belt securely fastened. Falling off power unit can result in death from being run over or crushed. Keep foldable ROPS system in "locked up" position at all times.**

■ **Inspect chain, rubber, or steel band shielding before each use. Replace if damaged.**

■ **Remove accumulated debris from this equipment, power unit, and engine to avoid fire hazard.**

■ **Make sure all safety decals are installed. Replace if damaged. (See Safety Decals section for location.)**

■ **Make sure shields and guards are properly installed and in good condition. Replace if damaged.**

■ **A minimum 20% of tractor and equipment weight must be on the tractor front wheels when attachments are in transport position. Without this weight, front tractor wheels could raise up resulting in loss of steering. The weight may be attained with front wheel weights, ballast in tires or front tractor weights. Weigh the tractor and equipment. Do not estimate.**

■ **Inspect and clear area of stones, branches, or other hard objects that might be thrown, causing injury or damage.**

OPERATION

■ **Do not allow bystanders in the area when operating, attaching, removing, assembling, or servicing equipment.**

(Safety Rules continued on next page)



SAFETY RULES

ATTENTION! BECOME ALERT! YOUR SAFETY IS INVOLVED!



(Safety Rules continued from previous page)

- Full chain, rubber, or steel band shielding must be installed when operating in populated areas or other areas where thrown objects could injure people or damage property.
 - If this machine is not equipped with full chain, rubber, or steel band shielding, operation must be stopped when anyone comes within 300 feet (92 m).
 - This shielding is designed to reduce the risk of thrown objects. The mower deck and protective devices cannot prevent all objects from escaping the blade enclosure in every mowing condition. It is possible for objects to ricochet and escape, traveling as much as 300 feet (92 m).
- Never direct discharge toward people, animals, or property.
- Do not operate or transport equipment while under the influence of alcohol or drugs.
- Operate only in daylight or good artificial light.
- Keep hands, feet, hair, and clothing away from equipment while engine is running. Stay clear of all moving parts.
- Always comply with all state and local lighting and marking requirements.
- Never allow riders on power unit or attachment.
- Power unit must be equipped with ROPS or ROPS cab and seat belt. Keep seat belt securely fastened. Falling off power unit can result in death from being run over or crushed. Keep foldable ROPS system in “locked up” position at all times.
- Always sit in power unit seat when operating controls or starting engine. Securely fasten seat belt, place transmission in neutral, engage brake, and ensure all other controls are disengaged before starting power unit engine.
- Operate tractor PTO at 540 RPM. Do not exceed.
- Do not operate PTO during transport.
- Look down and to the rear and make sure area is clear before operating in reverse.
- Do not operate or transport on steep slopes.
- Do not stop, start, or change directions suddenly on slopes.
- Use extreme care and reduce ground speed on slopes and rough terrain.
- Watch for hidden hazards on the terrain during operation.

- Stop power unit and equipment immediately upon striking an obstruction. Turn off engine, remove key, inspect, and repair any damage before resuming operation.
- Leak down or failure of mechanical or hydraulic system can cause equipment to drop.
- Before performing any service or maintenance, disconnect driveline from tractor PTO.

MAINTENANCE

- Before performing any service or maintenance, disconnect driveline from tractor PTO.
- Before working underneath, disconnect driveline, raise cutter, and block cutter securely. Hydraulic system leak down and failure of mechanical or hydraulic system can cause equipment to drop.
- Do not modify or alter or permit anyone else to modify or alter the equipment or any of its components in any way.
- Always wear relatively tight and belted clothing to avoid getting caught in moving parts. Wear sturdy, rough-soled work shoes and protective equipment for eyes, hair, hands, hearing, and head; and respirator or filter mask where appropriate.
- Make sure attachment is properly secured, adjusted, and in good operating condition.
- Do not allow bystanders in the area when operating, attaching, removing, assembling, or servicing equipment.
- Keep all persons away from operator control area while performing adjustments, service, or maintenance.
- Make certain all movement of equipment components has stopped before approaching for service.
- Frequently check blades. They should be sharp, free of nicks and cracks, and securely fastened.
- Do not handle blades with bare hands. Careless or improper handling may result in serious injury.
- Your dealer can supply genuine replacement blades. Substitute blades may not meet original equipment specifications and may be dangerous.
- Tighten all bolts, nuts, and screws to torque chart specifications. Check that all cotter pins are

SAFETY RULES



ATTENTION! BECOME ALERT! YOUR SAFETY IS INVOLVED!



installed securely to ensure equipment is in a safe condition before putting unit into service.

- Make sure all safety decals are installed. Replace if damaged. (See Safety Decals section for location.)
- Make sure shields and guards are properly installed and in good condition. Replace if damaged.

STORAGE

- Keep children and bystanders away from storage area.
- Disconnect cutter driveshaft and secure up off ground. Raise cutter with 3-point hitch. Place blocks under cutter side skids. Lower cutter onto blocks. Disconnect cutter from tractor 3-point hitch and carefully drive tractor away from cutter.



SAFETY & INSTRUCTIONAL DECALS



ATTENTION! BECOME ALERT! YOUR SAFETY IS INVOLVED!



Replace Immediately If Damaged!

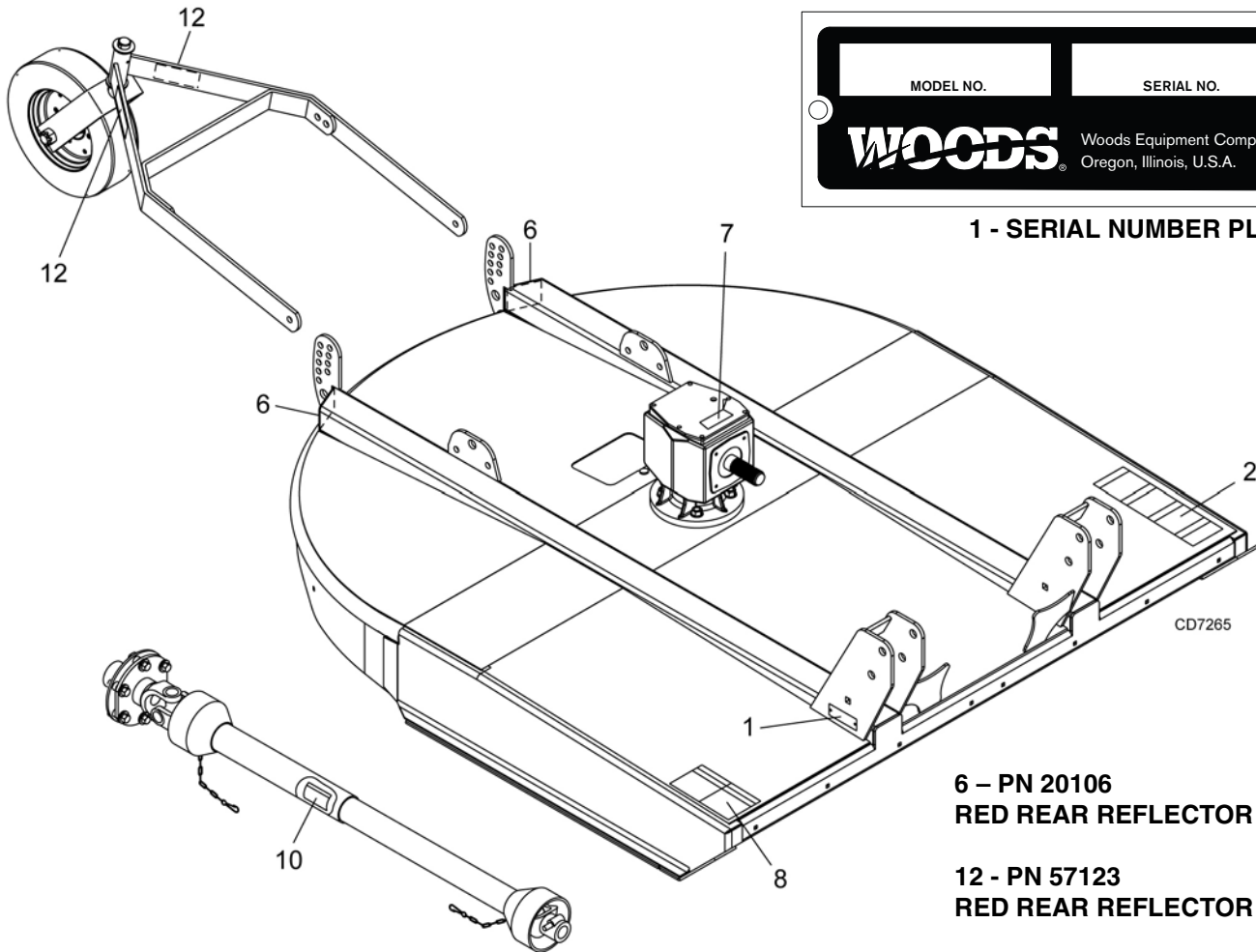

1 - SERIAL NUMBER PLATE

**6 - PN 20106
RED REAR REFLECTOR 4.5"**

**12 - PN 57123
RED REAR REFLECTOR 9"**

8 - PN 1006682

! DANGER

ROTATING BLADES AND THROWN OBJECTS

- Do not put hands or feet under or into mower when engine is running.
- Before mowing, clear area of objects that may be thrown by blade.
- Keep bystanders away.
- Keep guards in place and in good condition.

BLADE CONTACT OR THROWN OBJECTS CAN CAUSE SERIOUS INJURY OR DEATH.

! DANGER

ROTATING DRIVELINE CONTACT CAN CAUSE DEATH
KEEP AWAY!

DO NOT OPERATE WITHOUT -

- All driveline guards, tractor and equipment shields in place
- Drivelines securely attached at both ends
- Driveline guards that turn freely on driveline

1006682-A

SAFETY & INSTRUCTIONAL DECALS



ATTENTION! BECOME ALERT! YOUR SAFETY IS INVOLVED!



Replace Immediately If Damaged!

WARNING

CRUSHING AND PINCHING HAZARD

- Be extremely careful handling various parts of the machine. They are heavy and hands, fingers, feet, and other body parts could be crushed or pinched between tractor and implement.
- Operate tractor controls from tractor seat only.
- Do not stand between tractor and implement when tractor is in gear.
- Make sure parking brake is engaged before going between tractor and implement.
- Stand clear of machine while in operation or when it is being raised or lowered.

FAILURE TO FOLLOW THESE INSTRUCTIONS COULD RESULT IN SERIOUS INJURY OR DEATH.

2 - 1006681

DANGER

If shaft connection is visible, shield is missing. Replace shield before operating equipment.

1004114

7 - PN 1004114

WARNING

TO AVOID SERIOUS INJURY OR DEATH:

- Read Operator's Manual (available from dealer) and follow all safety precautions.
- Keep all shields in place and in good condition.
- Operate mower from tractor seat only.
- Lower mower, stop engine and remove key before dismounting tractor.
- Allow no children or untrained persons to operate equipment.
- Do not transport towed or semi-mounted units over 20 mph.

FAILURE TO OPERATE SAFELY CAN RESULT IN INJURY OR DEATH.

10 - PN 33347

DANGER

GUARD MISSING. DO NOT OPERATE.

DANGER

GUARD MISSING. DO NOT OPERATE.

33347E

DANGER

WARNING

FALLING OFF CAN RESULT IN BEING RUN OVER.

- Tractor must be equipped with ROPS (or ROPS CAB) and seat belt. Keep foldable ROPS systems in "locked up" position at all times.
- Buckle Up! Keep seat belt securely fastened.
- Allow no riders.

RAISED EQUIPMENT CAN DROP AND CRUSH.

- Before working underneath, follow all instructions and safety rules in operator's manual and securely block up all corners of equipment with jack stands.
- Securely blocking prevents equipment from dropping from hydraulic leakdown, hydraulic system failures or mechanical component failures.

FALLING OFF OR FAILING TO BLOCK SECURELY CAN RESULT IN SERIOUS INJURY OR DEATH.

BE CAREFUL!

Use a clean, damp cloth to clean safety decals.

Avoid spraying too close to decals when using a pressure washer; high-pressure water can enter through very small scratches or under edges of decals causing them to peel or come off.

Replacement safety decals can be ordered free from your Woods dealer. To locate your nearest dealer, check the Dealer Locator at www.WoodsEquipment.com, or in the United States and Canada call 1-800-319-6637.

WARNING

DO NOT EXCEED PTO SPEED OF 540 RPM

PTO speeds higher than 540 RPM can cause equipment failure and personal injury.

1006681

OPERATION

The operator is responsible for the safe operation of the cutter. The operator must be properly trained. Operators should be familiar with the cutter, the tractor, and all safety practices before starting operation. Read the safety rules and safety decals on page 7 through page 11.

This standard-duty cutter is designed for grass and weed mowing and shredding.

Recommended mowing speed for most conditions is from 2 to 5 mph.

! DANGER

■ Full chain, rubber, or steel band shielding must be installed when operating in populated areas or other areas where thrown objects could injure people or damage property.

- If this machine is not equipped with full chain, rubber, or steel band shielding, operation must be stopped when anyone comes within 300 feet (92 m).
- This shielding is designed to reduce the risk of thrown objects. The mower deck and protective devices cannot prevent all objects from escaping the blade enclosure in every mowing condition. It is possible for objects to ricochet and escape, traveling as much as 300 feet (92 m).

! WARNING

- Never allow riders on power unit or attachment.
- Keep bystanders away from equipment.
- Make sure spring-activated locking pin or collar slides freely and is seated firmly in tractor PTO spline groove.
- Operate tractor PTO at 540 RPM. Do not exceed.

! CAUTION

- Stop power unit and equipment immediately upon striking an obstruction. Turn off engine, remove key, inspect, and repair any damage before resuming operation.
- Always wear relatively tight and belted clothing to avoid getting caught in moving parts. Wear sturdy, rough-soled work shoes and protective equipment for eyes, hair, hands, hearing, and head; and respirator or filter mask where appropriate.

TRACTOR STABILITY

! WARNING

■ A minimum 20% of tractor and equipment weight must be on the tractor front wheels when attachments are in transport position. Without this weight, front tractor wheels could raise up resulting in loss of steering. The weight may be attained with front wheel weights, ballast in tires or front tractor weights. Weigh the tractor and equipment. Do not estimate.

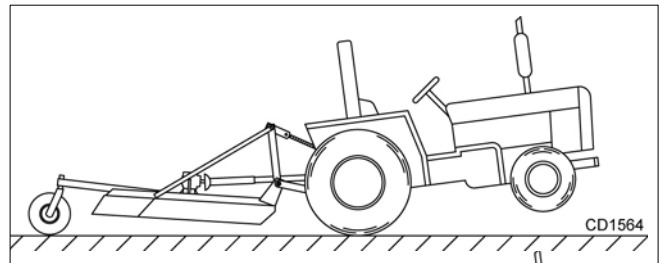

Figure 1. Tractor Stability

ATTACHING CUTTER TO TRACTOR - BB48X ONLY

! WARNING

■ Make sure spring-activated locking pin or collar slides freely and is seated firmly in tractor PTO spline groove.

! CAUTION

- Make sure driveline will not bottom out at the shortest length and that it has at least 1/3 overlap at the longest length.
- With cutter adjusted to transport position, set upper stop on tractor lift quadrant to prevent cutter from contacting the driveline when being raised.
- Select a top link mounting pin (maximum length 3-5/8") that will allow floating link to swing freely through the cutter A-frame bars.

1. Attach tractor 3-point lift arms to the cutter hitch pins and secure.
2. Attach tractor top link to cutter clevis using forward hole. Select a top link mounting pin that will allow floating link to swing freely through the cutter A-frame bars.

NOTE: You will need to adjust the top link; refer to **Top Link Adjustment - BB48X Only (Figure 2)**, page 13.

- Adjust the tractor lower 3-point arm anti-sway devices to prevent cutter from swinging side to side during transport.
- Adjust tractor drawbar so that it will not interfere with cutter or driveline.

Top Link Adjustment - BB48X Only (Figure 2)

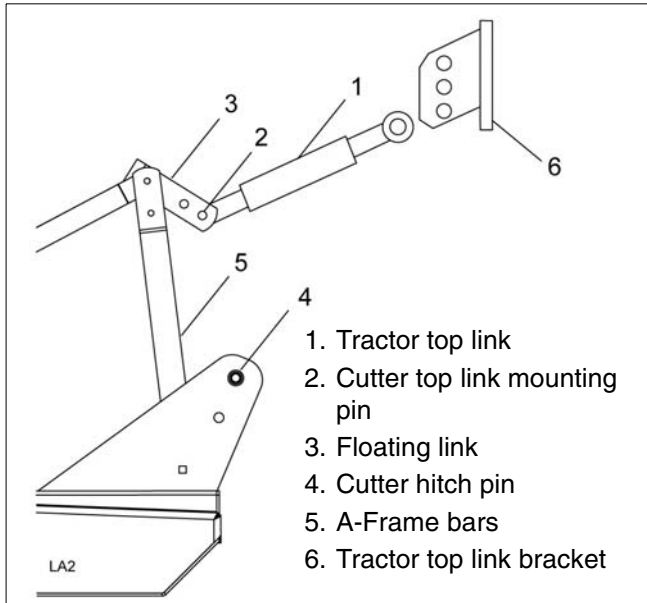

Figure 2. Top Link Adjustment - BB48X Only

- Attach tractor top link (1), to lowest hole provided in the tractor's top link bracket (6).

- Attach rear portion of tractor top link to the first hole on the cutter floating link (3). Select a top link mounting pin that will allow the floating link to swing freely through the cutter A-frame bars (5).
- Raise cutter to transport position and adjust tractor top link until cutter is level in the raised position.

NOTE: If you cannot level the cutter using the lowest hole in the tractor's top link bracket, move top link to the next hole and level the cutter.

Quick Hitch Attachment - BB48X Only (Figure 3)

- Remove brace arms (6), floating link (3), cap screw (11), spacer (7), and flange lock nut (9) from upper hole on A-frame bars (5) as shown on left in Figure 3.

NOTE: A-Frame bars are installed to mast plates with carriage bolts through the square holes.

- Attach open end of floating link (3) to the bottom hole of A-frame bars (5). Secure using cap screw (11), sleeve (10), and flange lock nut (9) as shown on right in Figure 3.

- Attach closed end of floating link (3) to diagonal braces (6). Secure using cap screw (8), spacer (7), and flange lock nut (9) supplied in hardware bag.

NOTE: Quick hitch top hook will pick up on sleeve (10). Lower quick hitch hook will attach to cutter hitch pins.

- Raise cutter to transport position and adjust tractor top link until cutter is level in the raised position.

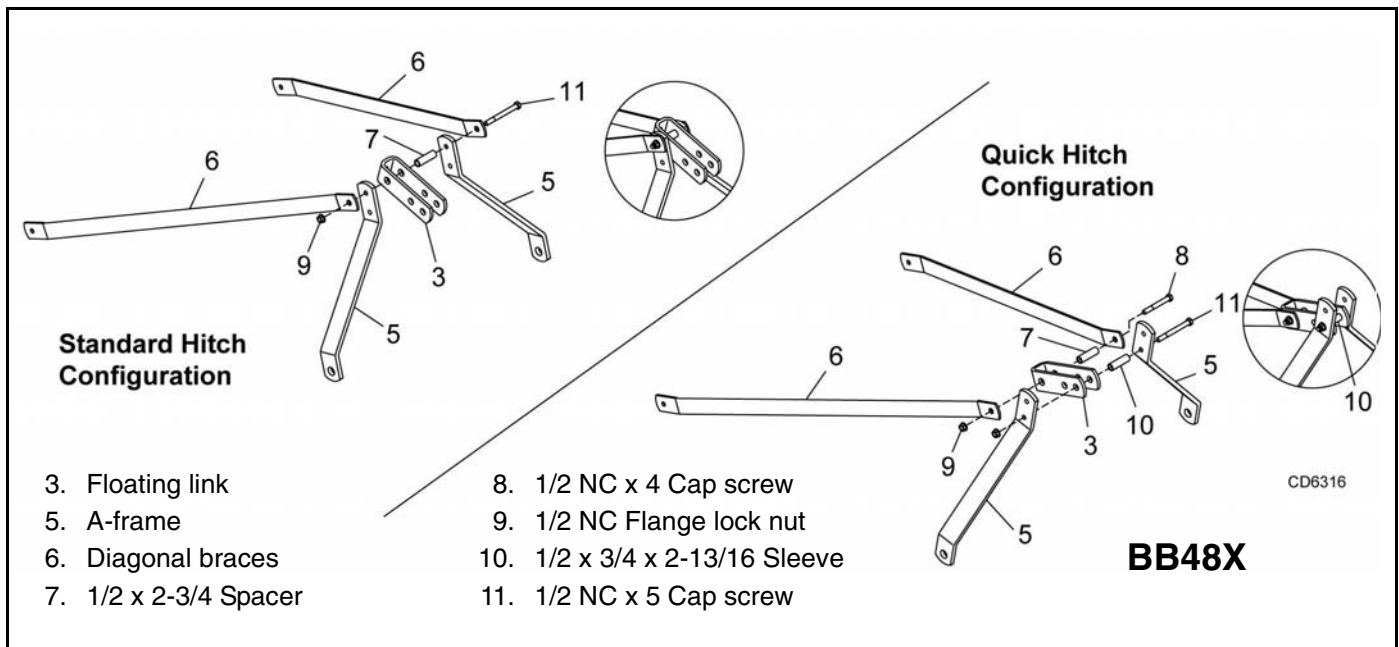

Figure 3. Standard Hitch and Quick Hitch Configurations - BB48X Only

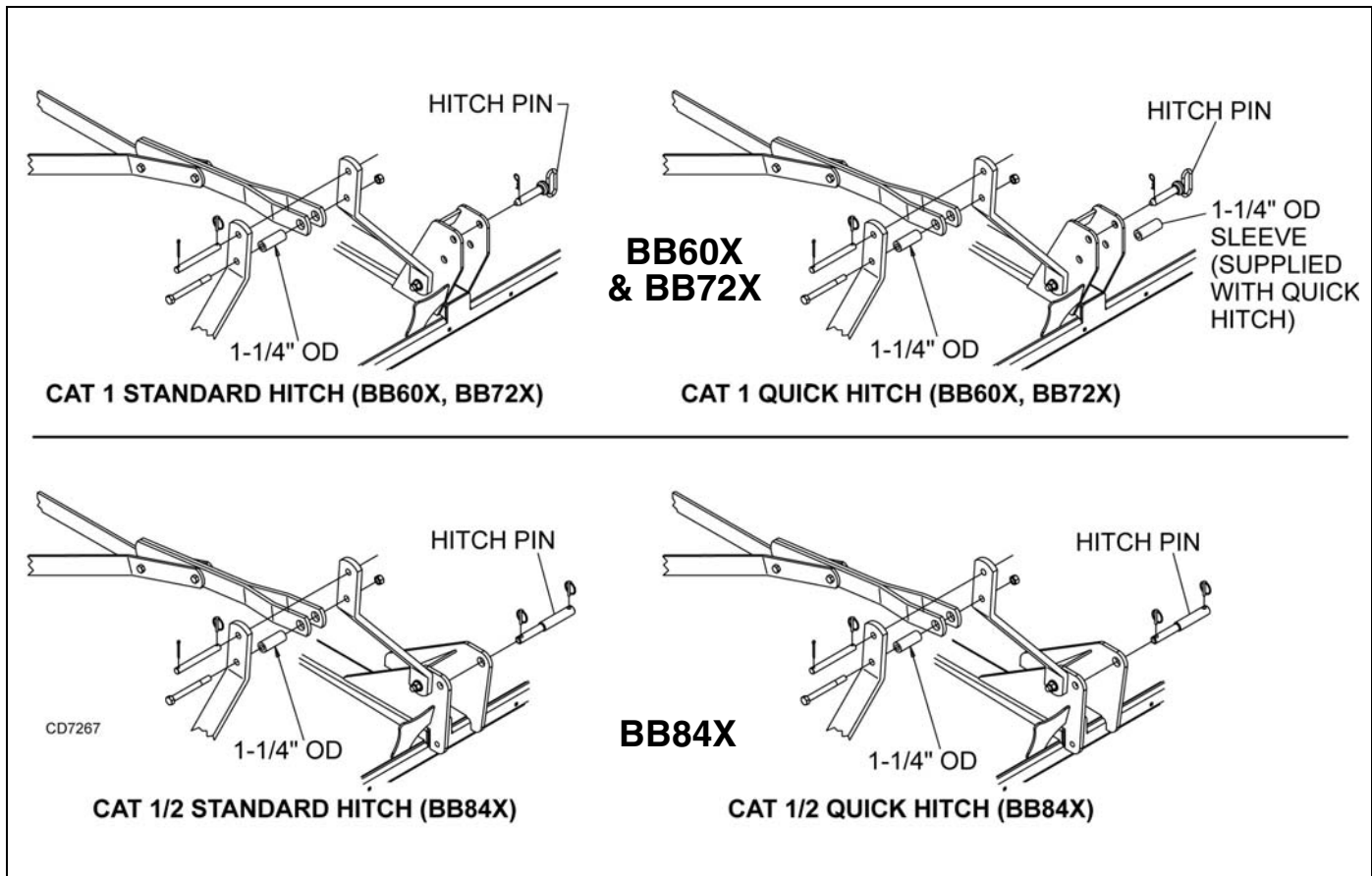

Figure 4. Standard Hitch and Quick Hitch Configurations - BB60X, BB72X & BB84X

ATTACHING CUTTER TO TRACTOR - BB60X, BB72X, BB84X ONLY

Standard Hitch

1. Position tractor 3-point arms between the mast plates and secure with hitch pins and cotter pin. See left side of Figure 4. Note pin orientation for the BB84X.
2. Connect the tractor top link to the cutter A-frame using the upper holes and the appropriate hardware. The break link must be placed in the lower holes of the A-frame.

Quick Hitch

1. Position tractor 3-point arms between the mast plates and secure with hitch pins and cotter pin. See right side of Figure 4. Note pin orientation for the BB84X.
2. Attach tractor with the quick hitch to the cutter and secure according to the quick hitch manufacturer's instructions.

INSTALLATION AND REMOVAL OF DRIVELINE (TRACTOR PTO)

To Install:

Pull locking collar back and at the same time push driveline onto tractor PTO shaft until locking device engages.

To Remove:

Hold driveline into position, pull locking collar back, and slide driveline off tractor PTO shaft.

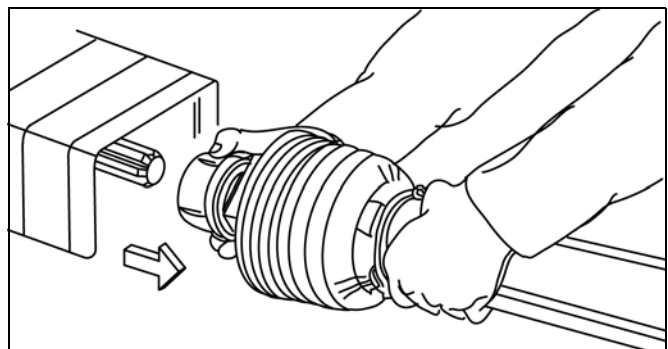

Figure 5. Lock Collar

DRIVELINE ATTACHMENT

Attach the cutter to the tractor 3-point hitch (or quick hitch if available). Do not attach driveline. Raise and lower cutter to determine maximum and minimum distance between the tractor PTO shaft and the gearbox input shaft. If the distance is too large, the driveline will be too short for proper engagement. If distance is too small, the driveline may bottom out in operation and damage the cutter or tractor.

The driveline length must be sufficient to provide at least 1/3 driveline length of engagement during operation. There must be at least 4 inches of engagement at the cutter's lowest possible point of operation. The driveline must not bottom out when raised to the maximum height possible.

If driveline is too short, please call your Woods dealer for a longer driveline.

If driveline is too long, please follow the instructions for shortening the driveline.

SHORTENING DRIVELINE

1. Move cutter up and down to get the shortest possible distance between tractor PTO shaft and gearbox input shaft.
2. Separate driveline into two halves and connect them to the tractor PTO and gearbox.
3. Place driveline halves parallel to one another to determine how much to shorten the driveline.



Figure 6. Drive Halves Placed Parallel

4. Measure from end of the upper shield to the base of the bell on the lower shield (A). Add 1-9/16" to dimension (A). See Figure 7.

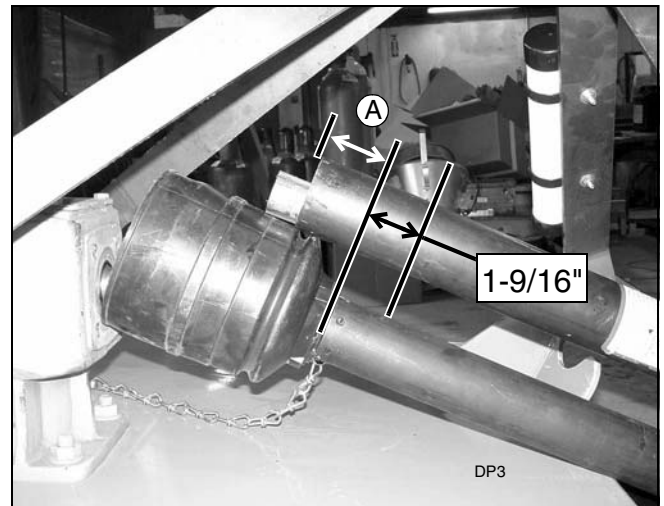

Figure 7. Determine Shield Length

5. Cut the shield to the overall dimension.

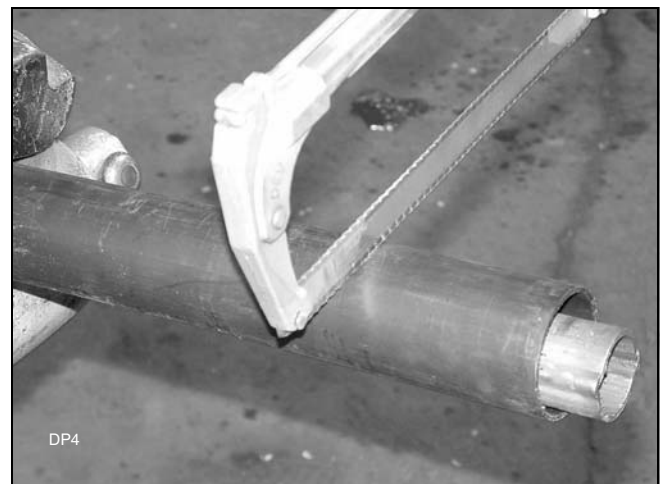

Figure 8. Cut Shield

6. Place the cutoff portion of the shield against the end of the shaft and use as a guide. Mark and cut the shaft.



Figure 9. Cut Shaft to Length

7. Repeat step 6 for the other half of the drive.

- File and clean cut ends of both drive halves.

Do not use tractor if proper driveline engagement cannot be obtained through these methods.

Connect driveline to tractor PTO shaft, making sure the spring-activated locking collar slides freely and locks driveline to PTO shaft.

NOTICE

■ If attaching with quick hitch, the distance between the tractor PTO and gearbox input shaft will increase. Please follow the steps as you would for a 3-point hitch to insure proper engagement.

DRIVELINE INTERFERENCE CHECK

- Check for clearance between driveline and cutter deck.
- Slowly lift cutter and observe driveline. If clearance between driveline and cutter deck is less than 1 inch, shorten top link or limit upper travel of lower hitch arms. Refer to tractor operator's manual for instructions.

CUTTING HEIGHT ADJUSTMENT

⚠ WARNING

■ Keep all persons away from operator control area while performing adjustments, service, or maintenance.

■ Avoid low cutting heights. Striking the ground with blades produces one of the most damaging shock loads a cutter can encounter. Allowing blades to contact ground repeatedly will cause damage to cutter and drive.

- Level cutter from side to side. Check by measuring from cutter frame to the ground at each deck rail.
- Adjust, using tractor 3-point arm leveling device.

NOTE: Keep the front of cutter slightly lower than rear for best mowing.
- Control cutting height with tractor 3-point arms, rear tailwheel adjustment, or optional check chains.
- To raise rear of cutter, move tailwheel arm down.
- To raise front of cutter, raise tractor 3-point arms or shorten optional check chains.

The cutting height is the distance between the blade and the ground. The blades are approximately 8.5" below the deck. To check cutting height, do the following:

- Place a straight edge along top edge of deck.
- Select a cutting height; as an example, for an approximate cutting height of 3", set the center of the deck 11.5" above the ground:

$$\begin{array}{r} 3" \text{ Desired cutting height} \\ + 8.5" \text{ Distance blade cutting edge is below deck} \\ \hline = 11.5" \end{array}$$

- Adjust the front-to-rear attitude from 1/2" to 3/4" higher than the front.
- Adjust top link (BB60X, BB72X, BB84X) to provide 2" of clearance between break link (2) and rear lift links. See Figure 10. The clearance will allow cutter to float over uneven terrain.

SHREDDING MATERIAL

For shredding, set the cutter lower at rear. Determine how much lower to set the rear by experimenting in different situations.

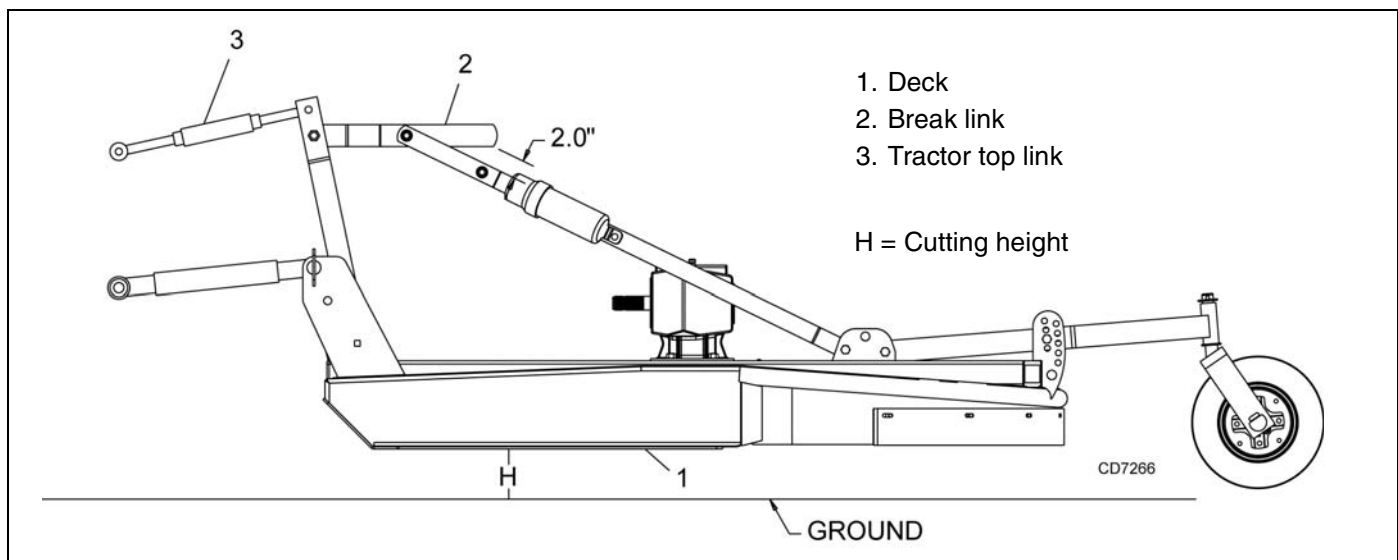

Figure 10. Cutting Height Adjustment

CHECK CHAIN ADJUSTMENT

1. Refer to **Install Optional Check Chains, page 42** for check chain installation.
2. After making cutting height adjustment, adjust both chains (3) in check chain bracket (2) so you have the same number of links on each side. This will keep cutting level.

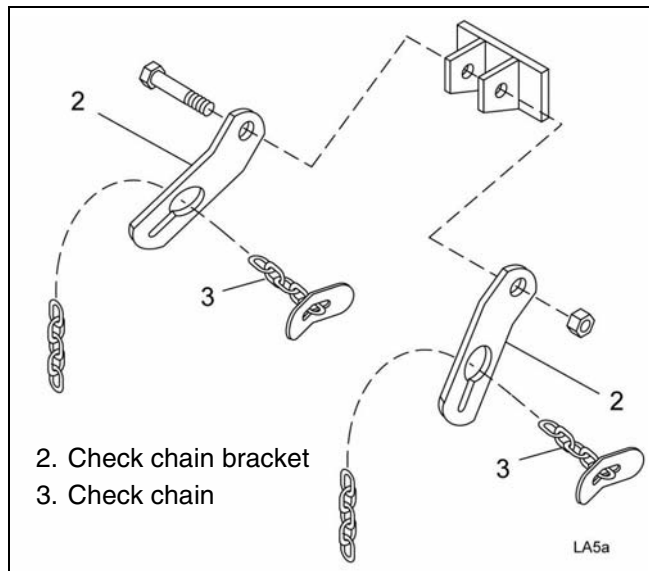

Figure 11. Check Chain Adjustment

OPERATING TECHNIQUE

1. Power for operating the cutter is supplied by the tractor PTO. Operate PTO at 540 rpm. Know how to stop the tractor and cutter quickly in an emergency.
2. Engage PTO at a low engine rpm to minimize stress on the drive system and gearbox. With PTO engaged, raise PTO speed to 540 rpm and maintain throughout cutting operation.

Gearbox protection is provided by a slip clutch with replacement fiber disc or a shear bolt. The slip clutch is designed to slip and the shear bolt will shear when excessive torsion loads occur.

3. Move slowly into material. Adjust tractor ground speed to provide a clean cut without lugging the tractor engine. Use a slow ground speed for better shredding.

Proper ground speed will depend on the terrain and the material's height, type, and density.

Normally, ground speed will range from 2 to 5 mph. Tall, dense material should be cut at a low speed; thin, medium-height material can be cut at a faster ground speed.

4. Always operate tractor PTO at 540 rpm to maintain proper blade speed and to produce a clean cut.
5. Under certain conditions tractor tires may roll down some grass and prevent cutting at the same height as the surrounding area. When this occurs, reduce your ground speed but maintain PTO at 540 rpm. The lower ground speed will permit grass to rebound partially.

STORAGE

⚠ WARNING

■ **Disconnect cutter driveshaft and secure up off ground. Raise cutter with 3-point hitch. Place blocks under cutter side skids. Lower cutter onto blocks. Disconnect cutter from tractor 3-point hitch and carefully drive tractor away from cutter.**

■ **Keep children and bystanders away from storage area.**

PRE-OPERATION CHECK LIST

OWNER'S RESPONSIBILITY

- ___ Review and follow all safety rules and safety decal instructions on page 7 through page 11.
- ___ Check that equipment is properly and securely attached to tractor.
- ___ Make sure driveline spring-activated locking pin or collar slides freely and is seated firmly in tractor PTO spline groove.
- ___ Set tractor PTO at 540 rpm.
- ___ Lubricate all grease fitting locations. Make sure PTO shaft slip joint is lubricated.
- ___ Check to be sure gear lube runs out the small check plug on side of gearbox.
- ___ Check that all hardware is properly installed and secured.
- ___ Check that blades are sharp and secure and cutting edge is positioned to lead in a counterclockwise rotation.
- ___ Check that shields and guards are properly installed and in good condition. Replace if damaged.
- ___ Check cutting height, front-to-rear attitude, and top link adjustment.
- ___ Place tractor PTO and transmission in neutral before starting engine.
- ___ Inspect area to be cut and remove stones, branches, or other hard objects that might be thrown and cause injury or damage.

OWNER SERVICE

The information in this section is written for operators who possess basic mechanical skills. If you need help, your dealer has trained service technicians available. For your protection, read and follow the safety information in this manual

WARNING

■ **Keep all persons away from operator control area while performing adjustments, service, or maintenance.**

CAUTION

■ **If you do not understand any part of this manual and need assistance, see your dealer.**

■ **Always wear relatively tight and belted clothing to avoid getting caught in moving parts. Wear sturdy, rough-soled work shoes and protective equipment for eyes, hair, hands, hearing, and head; and respirator or filter mask where appropriate.**

BLOCKING METHOD

WARNING

■ **Before performing any service or maintenance, disconnect driveline from tractor PTO.**

■ **Never go underneath equipment (lowered to the ground or raised) unless it is properly blocked and secured. Never place any part of the body underneath equipment or between moveable parts even when the engine has been turned off. Hydraulic system leak down, hydraulic system failures, mechanical failures, or movement of control levers can cause equipment to drop or rotate unexpectedly and cause severe injury or death. Follow Operator's Manual instructions for working underneath and blocking requirements or have work done by a qualified dealer.**

To minimize the potential hazards of working underneath the cutter, follow these procedures.

1. Jackstands with a load rating of 1000 lbs or more are the only approved blocking device for this cutter. Install a minimum of four jackstands (shown by Xs in Figure 12) under the cutter before working underneath unit.

Do not position jackstands under wheels, axles, or wheel supports. Components can rotate and cause cutter to fall.

2. Consider the overall stability of the blocked unit. Just placing jackstands underneath will not ensure your safety.

The working surface must be level and solid to support the weight on the jackstands. Make sure jackstands are stable, both top and bottom. Make sure cutter is approximately level.

3. With full cutter weight lowered onto jackstands, test blocking stability before working underneath.
4. If cutter is attached to tractor when blocking, set the brakes, remove key, and block cutter before working underneath.
5. Securely block rear tractor wheels, in front and behind. Tighten tractor lower 3-point arm anti-sway mechanism to prevent side-to-side movement.

LUBRICATION INFORMATION

1. Do not let excess grease collect on or around parts, particularly when operating in sandy areas.
2. See Figure 12 for lubrication points and frequency of lubrication based on normal operating conditions. Severe or unusual conditions may require more frequent lubrication.
3. Use a lithium grease of #2 consistency with a MOLY (molybdenum disulfide) additive for all locations unless otherwise noted. Be sure to clean fittings thoroughly before attaching grease gun. One good pump of most guns is sufficient when the lubrication schedule is followed.

Gearbox Lubrication

1. For gearbox, use a high quality gear oil with a viscosity index of 80W or 90W and an API service rating of GL-4 or -5 in gearboxes.
2. Fill gearbox until oil runs out the side plug on gearbox. Check gearbox daily for evidence of leakage, and contact your dealer if leakage occurs.

Driveline Lubrication

1. Lubricate the driveline slip joint every eight operating hours. Failure to maintain proper lubrication could result in damage to U-joints, gearbox, and driveline.
2. Lower cutter to ground, disconnect driveline from tractor PTO shaft, and slide halves apart but do not disconnect from each other.
3. Apply a bead of grease completely around male half where it meets female half. Slide drive halves over each other several times to distribute grease.

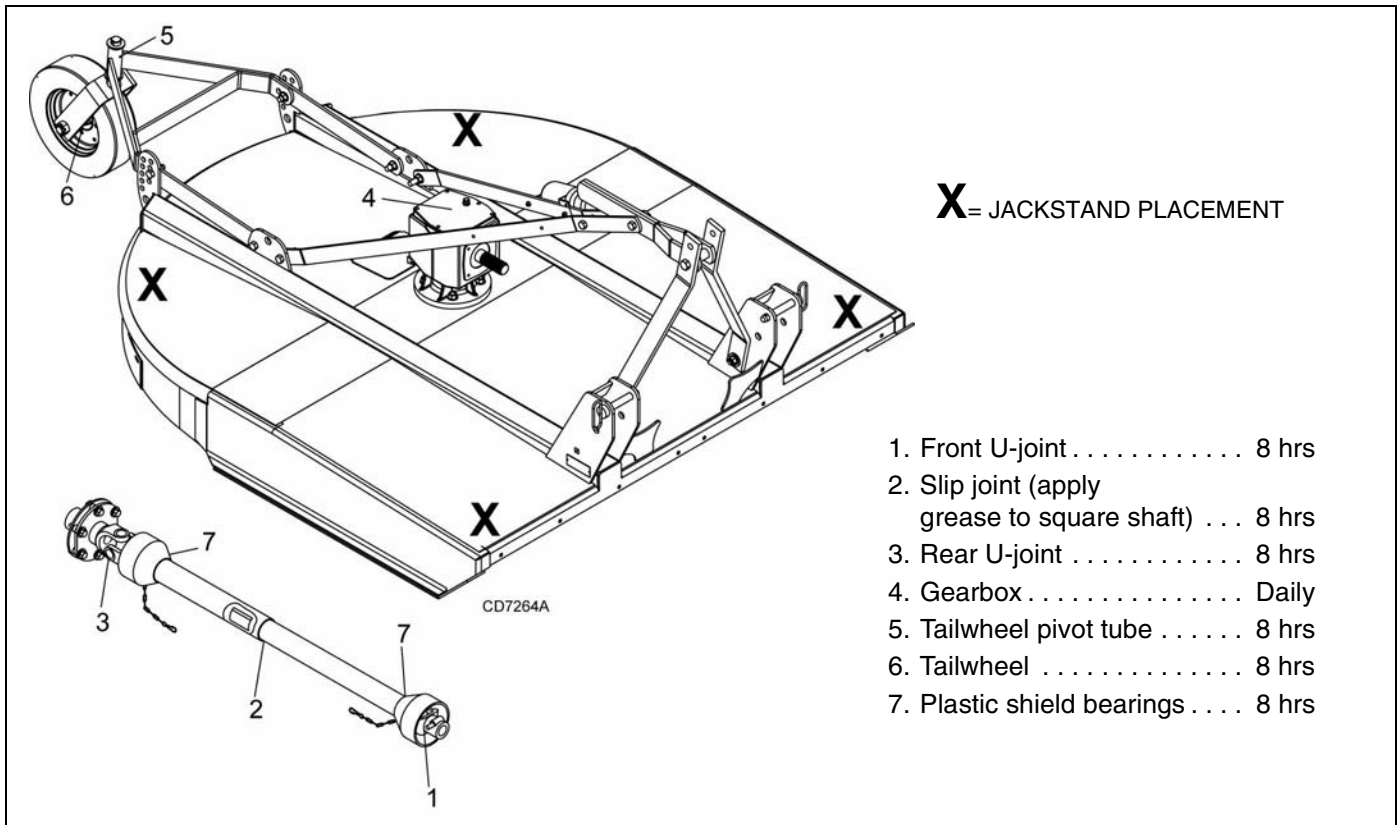

Figure 12. Jackstand Placement and Lubrication Points

BLADE SERVICING

Blade Removal (Figure 13)

NOTICE

■ If blade pin is seized in crossbar and extreme force will be needed to remove it, support crossbar from below to prevent gearbox damage.

2. Raise cutter and block securely (see Figure 12).
3. Align crossbar (8) with blade access hole in the cutter frame. Remove cap screw, blade pin lock clip, keyhole plate, and shims. Carefully drive pin out of crossbar.
4. Rotate crossbar (8) and repeat for opposite blade.

Blade Installation (Figure 13)

CAUTION

■ Your dealer can supply genuine replacement blades. Substitute blades may not meet original equipment specifications and may be dangerous.

■ Crossbar rotation is counterclockwise when looking down on cutter. Be sure to install blade cutting edge to lead in counterclockwise rotation.

NOTICE

■ Always replace or sharpen both blades at the same time.

1. Inspect blade pin (12) for nicks or gouges, and if you find any, replace the blade pin.
2. Insert blade pin through the blade (9). Blade should swivel on blade pin; if it doesn't, determine the cause and correct.

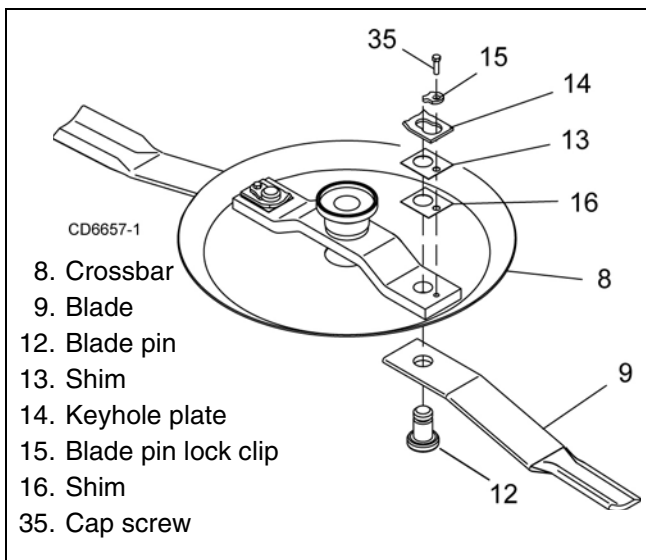

Figure 13. Blade Assembly

1. Disconnect driveline from tractor PTO.

3. Align crossbar (8) with blade access hole in cutter frame. Apply a liberal coating of Never Seez[®] or equivalent to blade pin and crossbar hole. Make sure blade offset is away from cutter. Push blade pin through crossbar. Pin should rotate freely prior to installing blade clip (15).

4. Install shims (13 & 16) over blade pin.

NOTE: Only use enough shims to allow keyhole plate (14) to slide into blade pin groove.

5. Install blade clip (15) over keyhole plate and into blade pin groove.

6. Secure into position with cap screw (35). Torque cap screw to 85 lbs-ft.

7. Repeat steps for opposite side.

NOTE: Blade should be snug but should swivel on pin without having to exert excessive force. Keep any spacers not used in the installation as replacements or for future installation.

Blade Sharpening

NOTICE

■ When sharpening blades, grind the same amount on each blade to maintain balance. Replace blades in pairs. Unbalanced blades will cause excessive vibration, which can damage gearbox bearings. Vibration may also cause structural cracks to cutter.

1. Sharpen both blades at the same time to maintain balance. Follow original sharpening pattern.

2. Do not sharpen blade to a razor edge—leave at least a 1/16" blunt edge.

3. Do not sharpen back side of blade.

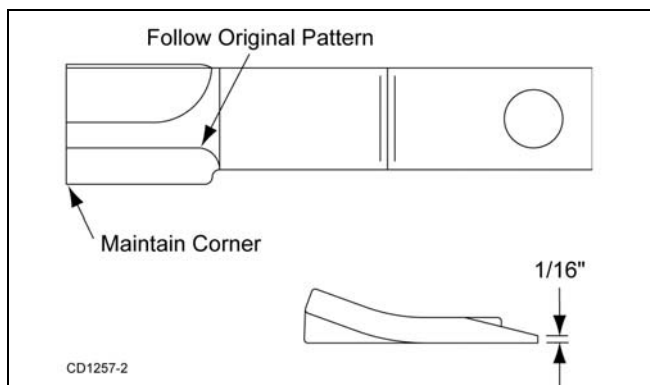

Figure 14. Blade Sharpening

SLIP CLUTCH ADJUSTMENT

The slip clutch is designed to slip so that the gearbox and driveline are protected if the cutter strikes an obstruction.

A new slip clutch or one that has been in storage over the winter may seize. Before operating the cutter, make sure it will slip by performing the following operation:

Comer

1. Turn off tractor engine and remove key.
2. Loosen nuts on springs until the springs can rotate freely, yet remain secure on the bolts.
3. Mark outer plates of slip-disc clutch as shown in Figure 15.
4. Securely attach implement to the tractor and start the tractor.
5. Engage PTO for several seconds then quickly disengage it.
6. Turn tractor off and remove key.
7. The friction lining plates should have "slipped". Check the marks placed on the outer plates of the slip-disc clutch in step 3 to make sure this is the case.
8. If clutch does not slip, check assembly for oil, grease and debris. Clean if necessary.
9. Reassemble clutch and tighten bolts no more than 1/8 of a turn at a time until desired setting of 1.26" on BB48X, BB60X and BB72X cutters is reached. For BB84X cutters, set to 1.36". See Figure 15.
10. If excessive slippage continues, check lining plates for excessive wear. They are 1/8" thick when new and should be replaced after 1/32" of wear to ensure proper operation.

Walterscheid (BB84X Only)

1. Turn off tractor engine and remove key.
2. Remove driveline from tractor PTO.
3. Loosen six 10 mm cap screws (6) to remove all tension from Belleville spring plate (5).
4. Hold clutch hub (3) solid and turn shaft to make sure clutch slips.
5. If clutch does not slip freely, disassemble and clean the thrust plate faces (4), flange yoke (1), and clutch hub (3).
6. Reassemble clutch. Tighten Belleville spring (5) until it is against the thrust plate (4) of the clutch, and then back off each of the six nuts by two full revolutions. The gap between Belleville spring and thrust plate should be 1/8" as shown in Figure 15.
7. If a clutch continues to slip when the spring is compressed to 1/8", check friction discs (2) for excessive wear. Discs are 1/8" when new. Replace discs after 1/16" wear. Minimum disc thickness is 1/16".

Comer

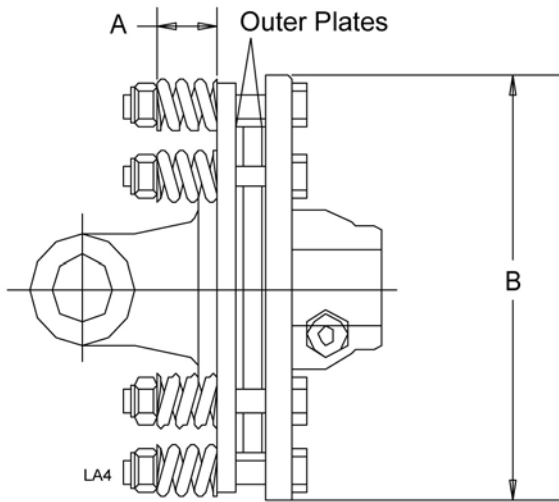

Model	"A"	"B"
BB48X	1.26"	7.09"
BB60X	1.26"	7.09"
BB72X	1.26"	7.09"
BB84X	1.36"	7.68"

Walterscheid

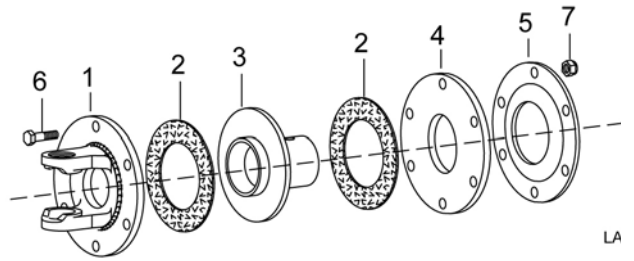

1. Flange yoke
2. Friction disc
3. Hub, 1-3/8" round bore
4. Thrust plate
5. Belleville spring plate
6. 10 mm x 1.5P x 55 mm Cap screw
7. 10 mm x 1.5P Hex nut

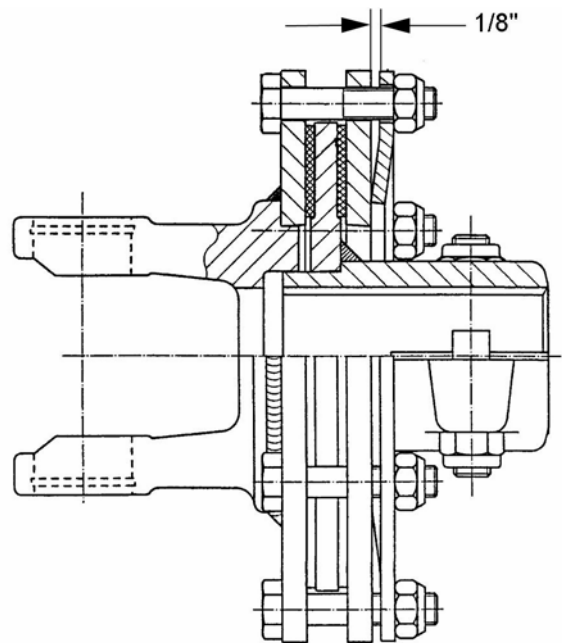

Figure 15. Slip Clutch Assembly

DRIVELINE SHEAR BOLT REPLACEMENT **(BB48X & BB60X ONLY)**

NOTICE

■ Always use approved 1/2" NC x 3" grade 2 shear bolt as a replacement part. Using a hardened bolt or shear pin may result in damage to driveline or gearbox.

1. Remove driveline shield bell (1).
2. Remove damaged shear bolt (4).
3. Rotate driveline to align holes in yoke and shaft. Install shear bolt and secure with lock nut. Replace driveline shield bell.

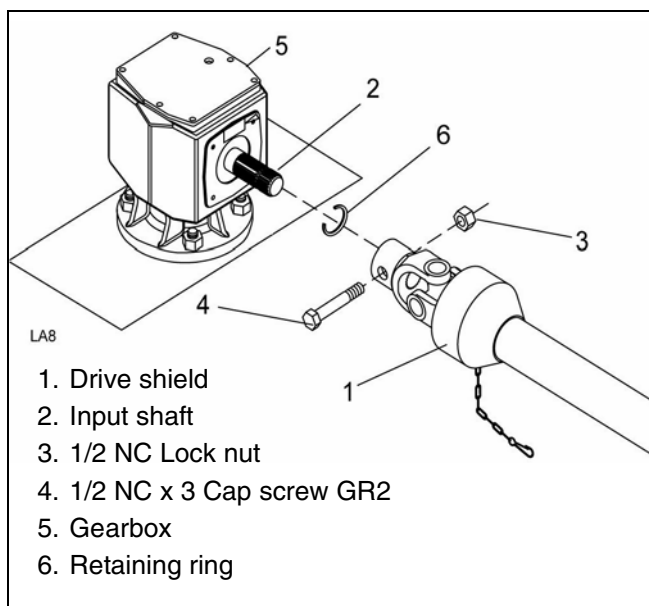

Figure 16. Shear Bolt Driveline Assembly - BB48X & BB60X

SHIELDING REPAIR

DANGER

■ Full chain, rubber, or steel band shielding must be installed when operating in populated areas or other areas where thrown objects could injure people or damage property.

- If this machine is not equipped with full chain, rubber, or steel band shielding, operation must be stopped when anyone comes within 300 feet (92 m).
- This shielding is designed to reduce the risk of thrown objects. The mower deck and protec-

tive devices cannot prevent all objects from escaping the blade enclosure in every mowing condition. It is possible for objects to ricochet and escape, traveling as much as 300 feet (92 m).

Rear Band

Inspect rear band each day of operation and replace if bent, cracked or broken.

Rubber Shielding

Inspect rubber shielding each day of operation and replace if cracked or broken.

Optional Chain Shielding

Inspect chain shielding each day of operation and replace any broken or missing chains as required.

CLEANING

After Each Use

- Remove large debris such as clumps of dirt, grass, crop residue, etc. from machine.
- Inspect machine and replace worn or damaged parts.
- Replace any safety decals that are missing or not readable.

Periodically or Before Extended Storage

- Clean large debris such as clumps of dirt, grass, crop residue, etc. from machine.
- Remove the remainder using a low-pressure water spray.
 1. Be careful when spraying near scratched or torn safety decals or near edges of decals as water spray can peel decal off surface.
 2. Be careful when spraying near chipped or scratched paint as water spray can lift paint.
 3. If a pressure washer is used, follow the advice of the pressure washer manufacturer.
- Inspect machine and replace worn or damaged parts.
- Sand down scratches and the edges of areas of missing paint and coat with Woods spray paint of matching color (purchase from your Woods dealer).
- Replace any safety decals that are missing or not readable (supplied free by your Woods dealer). See Safety Decals section for location drawing.

TROUBLESHOOTING

MOWING CONDITIONS

PROBLEM	POSSIBLE CAUSE	SOLUTION
Grass cut lower in center of swath than at edge	Height of cutter lower at rear or front	Adjust cutter height and attitude so that cutter rear and front are within 1/2" of same height.
Streaking conditions in swath	Conditions too wet for mowing	Allow grass to dry before mowing.
	Blades unable to cut that part of grass pressed by path of tractor tires	Slow ground speed of tractor but keep engine running at full PTO RPM. Cutting lower will help.
	Dull blades	Sharpen or replace blades.
Material discharges from cutter unevenly; bunches of material along swath	Material too high and too much material	Reduce ground speed but maintain 540 RPM at tractor PTO or make two passes over material. Raise cutter for the first pass and lower to desired height for the second and cut at 90° to first pass. Raise rear of cutter high enough to permit material to discharge but not so high as to cause conditions listed above.
	Grass wet	Allow grass to dry before mowing. Slow ground speed of tractor but keep engine running at full PTO RPM. Cutting lower will help.
	Rear of cutter too low, trapping material under cutter	Adjust cutter height and attitude.
Cutter will not cut (Shear bolt drive only)	Shear bolt sheared	Install new shear bolt.
Cutter will not cut all the time (Slip clutch drive only)	Slip clutch slipping	Adjust slip clutch according to instructions in Slip Clutch Adjustment, page 20.

DEALER SERVICE

The information in this section is written for dealer service personnel. The repair described here requires special skills and tools. If your shop is not properly equipped or your mechanics are not properly trained in this type of repair, you may be time and money ahead to replace complete assemblies.

WARNING

■ Before working underneath, disconnect drive-line, raise cutter, lock in transport position, and block cutter securely. Hydraulic system leak down and failure of mechanical or hydraulic system can cause equipment to drop.

■ Keep all persons away from operator control area while performing adjustments, service, or maintenance.

CAUTION

■ Always wear relatively tight and belted clothing to avoid getting caught in moving parts. Wear sturdy, rough-soled work shoes and protective equipment for eyes, hair, hands, hearing, and head; and respirator or filter mask where appropriate.

GEARBOX MAINTENANCE

NOTE: Read this entire section before starting any repair. Many steps are dependent on each other.

1. Fill gearbox with SAE 80W or 90W gear lube until it runs out the side level plug.

NOTE: Repair to this gearbox is limited to replacing bearings, seals, and gaskets. Replacing gears, shafts, and a housing is not cost effective. Purchasing a complete gearbox is more economical.

2. Inspect gearbox for leakage and bad bearings. Leakage is a very serious problem and must be corrected immediately. Bearing failure is indicated by excessive noise and side-to-side or end-play in gear shafts.

Seal Replacement

Recommended sealant for gearbox repair is Permatex® Aviation 3D Form-A-Gasket or equivalent.

Leakage can occur at the vertical or horizontal gaskets and shaft seals.

Leakage at the horizontal gasket or seal can be repaired without removing the gearbox from the cutter.

Seal Installation

NOTE: Proper seal installation is important. An improperly installed seal will leak.

1. Clean area in housing where seal outer diameter (OD) seats. Apply a thin coat of Permatex.
2. Inspect area of shaft where seal seats. Remove any burrs or nicks with an emery cloth.
3. Lubricate gear shaft and seal lips.
4. Place seal squarely on housing, spring-loaded lip toward housing. Select a piece of pipe or tubing with an OD that will sit on the outside edge of the seal but will clear the housing. Tubing with an OD that is too small will bow seal cage and ruin seal.
5. Carefully press seal into housing, avoiding distortion to the metal seal cage.

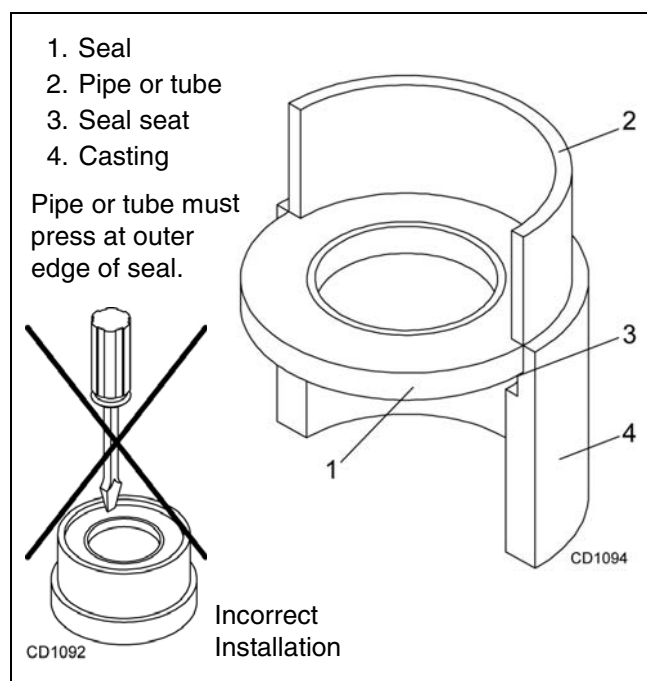

Figure 17. Seal Installation

SEAL REPAIR
(ON FLAT TOP, BB48X, BB60X, BB72X
S/N 1159928 AND BEFORE; BB84X)

(Figure 18)

Vertical Shaft Seal Repair

1. Disconnect and remove the rear driveline from the gearbox.
2. Remove vent plug (27) and siphon gear lube from housing through this opening.
3. Remove crossbar (see **Crossbar Removal, page 31**).
4. Remove vertical shaft seal (21). Replace with new seal (see **Seal Installation, page 24**).

Vertical seal should be recessed in housing. Horizontal seal should be pressed flush with outside of housing.

NOTE: Distortion to seal cage or damage to seal lip will cause seal to leak.

5. Fill gearbox with SAE 80W or 90W gear lube until it runs out the level plug.
6. Remove and replace any seal damaged in installation.

Horizontal Seal Leak Repair

1. Disconnect and remove the rear driveline from the gearbox.
2. Remove vent plug (27) and siphon gear lube from housing through this opening.
3. If the leak occurred at either end of horizontal shaft, remove oil cap (23) and/or oil seal (22). Replace with new one (refer to **Seal Installation, page 24**).
4. Fill gearbox with SAE 80W or 90W gear lube until it runs out the level plug.

GEARBOX REPAIR
(ON FLAT TOP, BB48X, BB60X, BB72X
S/N 1159928 AND BEFORE; BB84X)

(Figure 18)

NOTE: Repair to this gearbox is limited to replacing bearings, seals, and gaskets. Replacing gears, shafts, and a housing is not cost effective. Purchasing a complete gearbox is more economical.

Remove Gearbox from Cutter

1. Disconnect and remove the rear driveline from the gearbox.
2. Remove vent plug (27) and siphon gear lube from housing through this opening.

3. Remove cotter pin, washer, and nut from vertical shaft and remove crossbar (see **Crossbar Removal, page 31**).
4. Remove the four bolts that attach gearbox to cutter and remove gearbox.

Disassemble Gearbox

1. Remove 3/8" plug from side of gearbox and pour out gear oil.
2. Remove oil cap (23) (to be replaced).
3. Remove snap ring (12) and shim (15) from input shaft (3).
4. Support gearbox in hand press and push on input shaft (3) to remove bearing (9) and spacer (14).
5. Remove top cover (25) from housing. Remove gear (1) from inside housing.
6. Remove oil seal (22) from front of housing (to be replaced).
7. Remove snap ring (12) and shim (15) from front of housing (2).
8. Remove input bearing (8) by using a punch and hammer from outside of housing.
9. Support housing in vise in a horizontal position.
10. The castle nut (17), cotter pin (28), washer (18), and hub (24) are already removed with the stump jumper/crossbar. Remove the snap ring (10), washer (19), and seal (21).
11. Remove cotter pin (11), castle nut (16), and washer (20) from output shaft (4).
12. Remove output shaft (4) by using a punch and hammer and tap on top to drive down.
13. Remove gear (5) and shim (15) from inside housing.
14. Remove bearing (7) by using a punch and hammer from the top, outside the housing.
15. Support housing upside down (top cover surface) and remove bearing (6) by using a punch and hammer from the bottom side of the housing.
16. Inspect gears for broken teeth and wear. Some wear is normal and will show on loaded side. Forged gear surfaces are rough when new. Check that wear pattern is smooth.
17. Inspect vertical and horizontal shafts for grooves, nicks, or bumps in the areas where the seals seat. Resurface any damage with emery cloth.
18. Inspect housing and caps for cracks or other damage.

Reassemble Gearbox

1. Clean housing, paying specific attention to areas where gaskets will be installed.
2. Wash housing and all components thoroughly. Select a clean area for gearbox assembly. Replace all seals, bearings, and gaskets. All parts must be clean and lightly oiled before reassembling.
3. Insert output bearings (6 & 7) in the housing, using a round tube of the correct diameter and a hand press.
4. Slide output shaft (4) through both bearings (6 & 7) until it rests against bearing (6).
5. Slide shim (15) over output shaft (4).
6. Press gear (5) onto output shaft (4) and secure with washer (20), castle nut (16), and cotter pin (11).
7. Apply grease to lower seal lips (21) and press seal (21) over output shaft (4), using a tube of the correct diameter. Be sure not to damage the seal lip.

Press in housing so that seal is recessed. Insert protective washer (19) by hand. Install snap ring (10) and position it together with dual lip seal (21) by pressing it into position. Verify that snap ring is seated correctly.
8. Press bearing (8) into the housing, using a round tube of the correct diameter and a hand press. Secure with shim (15) and snap ring (12).
9. Secure snap ring (13) on input shaft (3) if not already secure.
10. Place gear (1) through top of housing and align gear (1) and gear (5) so that gear teeth are a match.
11. While holding gear (1) in place, slide input shaft (3) through gear (1) and bearing (8). Align splines on shaft (3) and gear (1).

12. Slide spacer (14) over input shaft (3) and press bearing onto input shaft (3), using a round tube of the correct diameter and a hand press.
13. Slide shim (15) over input shaft (3) and secure with snap ring (12).
14. Check input shaft end float by moving the input shaft (3) by hand. If end float is higher than 0.012", insert shim between input shaft (3) and rear bearing (8). Repeat until end float is less than 0.012". Check rotational torque by hand. The torque should be less than 2.2 lbs-inch.
15. Check that the gear backlash is between 0.006" and 0.016". You should not have to adjust the backlash.
16. Press in input oil seal (22), using tube of correct diameter. Be careful not to damage seal lip.
17. Press oil cap (23) on to cover the rear of housing, using a tube of the correct diameter.
18. Check gearbox housing for leaks by plugging all holes except one. Apply 4 psi compressed air and immerse the gearbox in water to verify that there are no leaks.
19. Remove gearbox from water and dry off with compressed air. Add SAE 80W or 90W EP oil until it runs out of side level hole. Tighten all plugs.

Reinstall Gearbox

NOTE: Gearbox is heavy: do not attempt to move without mechanical assistance.

1. Set gearbox on cutter and fasten with bolts and nuts. Torque bolts as follows:

BB48X, BB60X, BB72X . . . 175 lbs-ft
BB84X 300 lbs-ft
2. Attach crossbar (See **Crossbar Installation, page 32**).

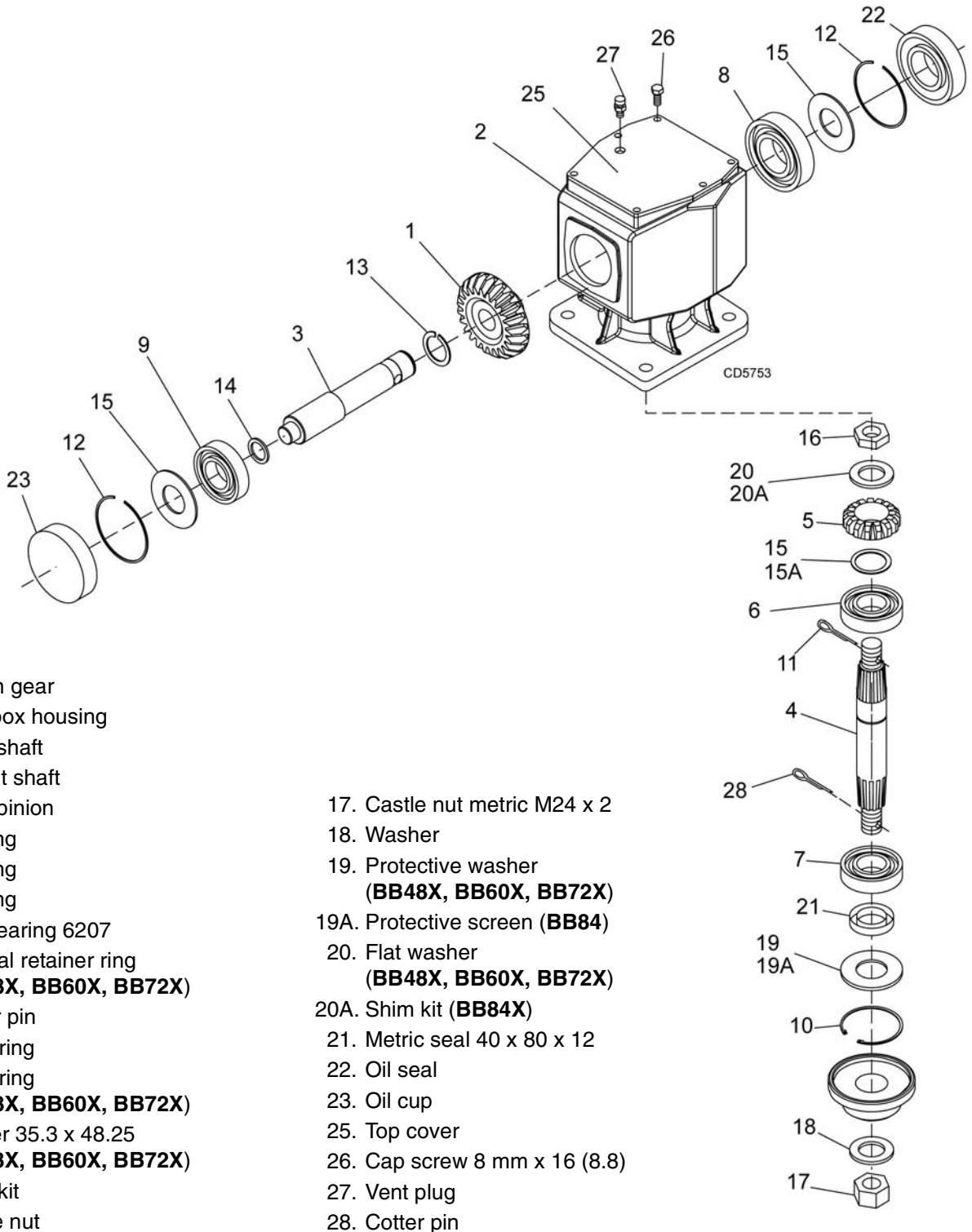

Figure 18. Gearbox Assembly

SEAL REPAIR
(ON CAST/CROWN TOP BB48X, BB60X,
BB72X - S/N 1159929 AND ABOVE ONLY)
(Figure 19)

Vertical Shaft Seal Repair

1. Disconnect and remove the rear driveline from the gearbox.
2. Remove vent plug (9) and siphon gear lube from housing through this opening.
3. Remove crossbar (see **Crossbar Removal, page 31**).
4. Remove output cap (17) and output seal (16) by removing four cap screws (13) and washers (12). Replace with new seal (see **Seal Installation, page 24**).

Vertical seal should be recessed in output cap.

NOTE: Distortion to seal cage or damage to seal lip will cause seal to leak.

5. Secure output cap (17) on to bottom of gearbox using four cap screws (13) and lock washers (12).

NOTE: Make sure output gasket (10) and (11) are in place.

6. Fill gearbox with SAE 80W or 90W gear lube until it runs out the side level plug.
7. Remove and replace any seal damaged in installation.

Horizontal Seal Leak Repair

1. Disconnect and remove the rear driveline from the gearbox.
2. Remove vent plug (9) and siphon gear lube from housing through this opening.
3. Remove input seal (4). Replace with new one (refer to **Seal Installation, page 24**).
4. Fill gearbox with SAE 80W or 90W gear lube until it runs out the side level plug.

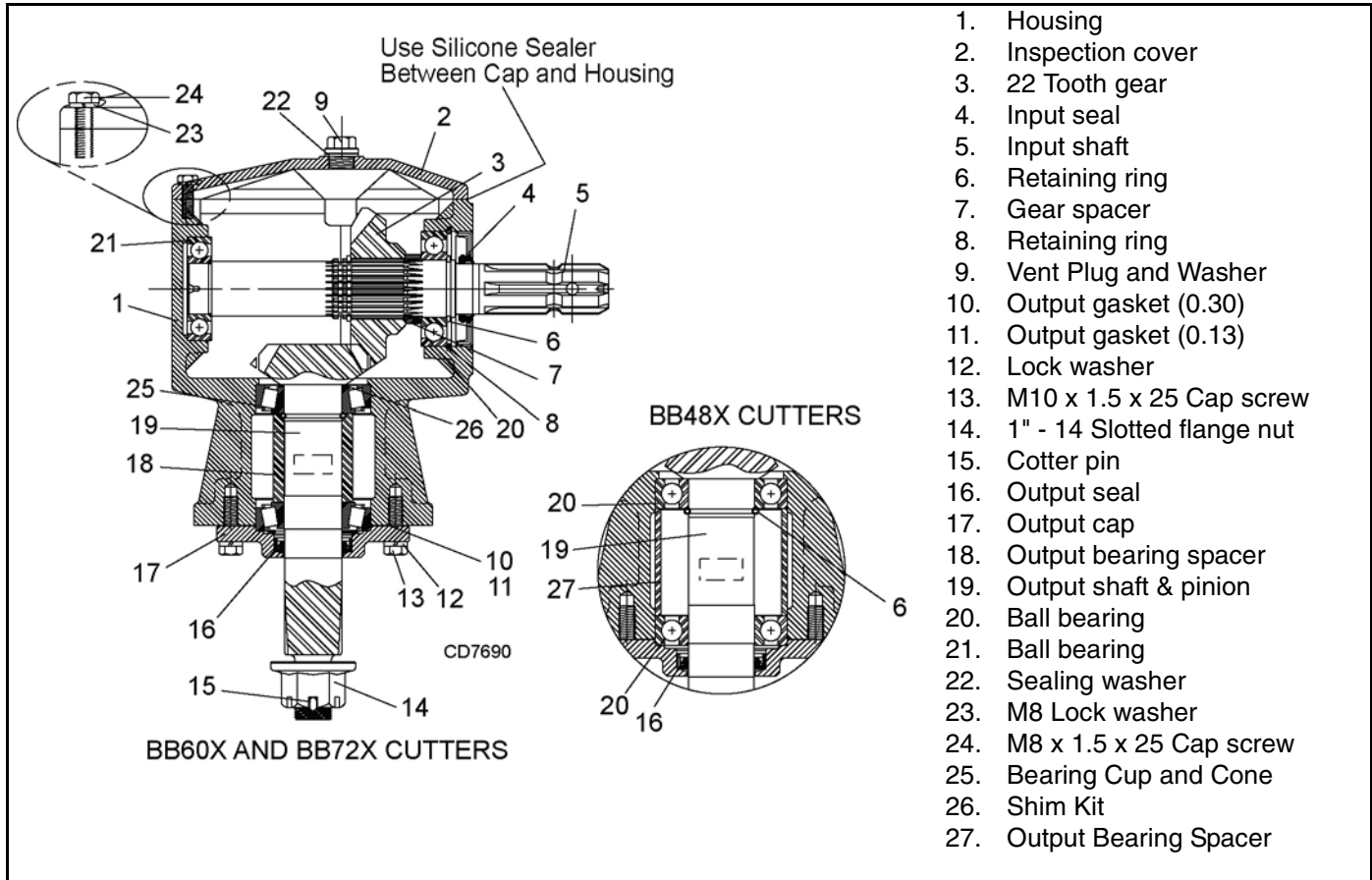

Figure 19. Cast/Crown Top Gearbox Assembly

GEARBOX REPAIR
(ON CAST/CROWN TOP BB48X, BB60X,
BB72X - S/N 1159929 AND ABOVE ONLY)
(Figure 19)

NOTE: Repair to this gearbox is limited to replacing bearings, seals, and gaskets. Replacing gears, shafts, and a housing is not cost effective. Purchasing a complete gearbox is more economical.

NOTE: Replacing a complete flat top gearbox with a complete crown top gearbox will require replacing the cross bar assembly. See pages 44 and 45.

Gearbox is heavy: do not attempt to move without mechanical assistance.)

Remove Gearbox from Cutter

1. Disconnect and remove the rear driveline from the gearbox.
2. Remove vent plug (9) and siphon gear lube from housing through this opening.
3. Remove cotter pin or wire, washer, and nut from vertical shaft and remove crossbar (see **Crossbar Removal, page 31**).
4. Remove the four bolts that attach gearbox to cutter and remove gearbox.

Disassemble Gearbox

1. Remove plug from side of gearbox and pour out remaining gear oil.
2. Support housing in vise in a vertical position.
3. Remove input seal (4) (to be replaced).
4. Remove retaining rings (6) and (8).
5. Remove the six cap screws (24), washers (23) and top cover (2) from housing.
6. Remove retaining ring (6) behind gear (3).
7. Support gearbox in hand press and pull input shaft (5) through gear (3). Remove ball bearing (21).
8. Remove ball bearing (20) and gear spacer (7) from input shaft (5).
9. Support housing in vise in a horizontal position.
10. With the hub/stump jumper/crossbar, castle nut, cotter pin, wire and washer already removed, remove the four cap screws (13), lock washers (12) and output cap (17).
11. Remove output gaskets (11) and (10).
12. Push output shaft and pinion (19) down and remove ball bearing (20) or tapered roller bearings

(25), output bearing spacer (18), and retaining ring (6). Remove output shaft and pinion (19).

NOTE: On gearboxes with tapered roller bearings, it will be necessary to use a punch to drive out bearing cups.

13. Inspect gears for broken teeth and wear. Some wear is normal and will show on loaded side. Forged gear surfaces are rough when new. Check that wear pattern is smooth.
14. Inspect vertical and horizontal shafts for grooves, nicks, or bumps in the areas where the seals seat. Resurface any damage with emery cloth.
15. Inspect housing and caps for cracks or other damage.

Reassemble Gearbox - Cast Top (BB48X)

1. Clean housing, paying specific attention to areas where gaskets will be installed.
2. Wash housing and all components thoroughly. Select a clean area for gearbox assembly. Replace all seals, bearings, and gaskets. All parts must be clean and lightly oiled before reassembling.
3. Slide ball bearing (20) on to output shaft and pinion (19). Place against gear and secure with retaining ring (6).
4. Push output shaft and pinion (19), ball bearing (20) and retaining ring (6) into housing until ball bearing (20) seats flat in housing socket.
5. Insert output bearing spacer (18) and ball bearing (20) over output shaft until seats against inside roller bearing (20).
6. Secure output cap (17) with new output seal (16) installed to bottom of gearbox housing using the four 10mm x 1.5 x 25 cap screws (13) and lock washers (12).
NOTE: Be sure output gaskets (10 and 11) are in place. Apply grease to output seal (16) lip for easy installation.
7. Place ball bearing (21) at back of housing and press in socket using a round tube of the correct diameter and a hand press until fully seated.
8. Insert input shaft (5) part way through housing and slide gear (3) and retaining ring (6) over input shaft (5). Keep gear (3) and retaining ring (6) loose.
9. Insert input shaft (5) into roller bearing (21) until seated against each other.
10. Slide gear (3) forward and attach retaining ring (6) in groove closest to front of input shaft (5). Slide gear (3) back against retaining ring (6).

11. Check that the gear backlash is between 0.006" and 0.016". You should not have to adjust the backlash.
12. Slide gear spacer (7) and roller bearing (20) on input shaft (5) and secure with retaining rings (6) and (8).
13. Slide input seal (4) onto input shaft (5) and press into housing flush with front using a tube of correct diameter. Be careful not to damage seal lip.
14. Check gearbox housing for leaks by plugging all holes except one. Apply 4 psi compressed air and immerse the gearbox in water to verify that there are no leaks.
15. Remove gearbox from water and dry off with compressed air. Add SAE 80W or 90W EP oil until it runs out of side level hole. Tighten all plugs.

Reassemble Gearbox - Cast Top (BB60X and BB72X)

1. Clean housing, paying specific attention to areas where gaskets will be installed.
2. Wash housing and all components thoroughly. Select a clean area for gearbox assembly. Replace all seals, bearings, and gaskets. All parts must be clean and lightly oiled before reassembling.
3. Insert upper output bearing cups (25) in the housing and press using a round tube with the correct diameter.
4. Slide shims (26) over output shaft (16). Use the same thickness as removed as a starting point.
5. Push bearing cone (25) onto output shaft (16). Shims maybe required between cone (25) and retaining ring (6) to eliminate any space.
NOTE: Make sure there is no endplay or gaps in this assembly.
6. Insert output bearing spacer (18) and bearing cone (25) over output shaft until seats against upper

bearing (25). Press lower bearing cup into position as shown.

7. Secure output cap (17) with new output seal (16) installed to bottom of gearbox housing using the four 10mm x 1.5 x 25 cap screws (13) and lock washers (12). Use shim gaskets (10) and (11) to adjust output bearings to a rolling torque of 9 to 12 In-lbs.
NOTE: Be sure output gaskets (10 and 11) are in place. Apply grease to output seal (16) lip for easy installation.
8. Place ball bearing (21) at back of housing and press in socket using a round tube of the correct diameter and a hand press until fully seated.
9. Insert input shaft (5) part way through housing and slide gear (3) and retaining ring (6) over input shaft (5). Keep gear (3) and retaining ring (6) loose.
10. Insert input shaft (5) into roller bearing (21) until seated against each other.
11. Slide gear (3) forward and attach retaining ring (6) in groove closest to front of input shaft (5). Slide gear (3) back against retaining ring (6).
12. Check that the gear backlash is between 0.006" and 0.016". You should not have to adjust the backlash.
13. Slide gear spacer (7) and ball bearing (20) on input shaft (5) and secure with retaining rings (6) and (8).
14. Slide input seal (4) onto input shaft (5) and press into housing flush with front using a tube of correct diameter. Be careful not to damage seal lip.
15. Check gearbox housing for leaks by plugging all holes except one. Apply 4 psi compressed air and immerse the gearbox in water to verify that there are no leaks.

Remove gearbox from water and dry off with compressed air. Add SAE 80W or 90W EP oil until it runs out of side level hole. Tighten all plugs.

CROSSBAR REMOVAL

1. It is necessary to gain access to bottom side of cutter for crossbar removal. See **OWNER SERVICE, page 18.**

NOTE: You will need to use either the puller screw (Item 6, Figure 21) or a small hydraulic jack to remove the crossbar.

2. To make crossbar removal easier, remove blades as shown in Figure 20.

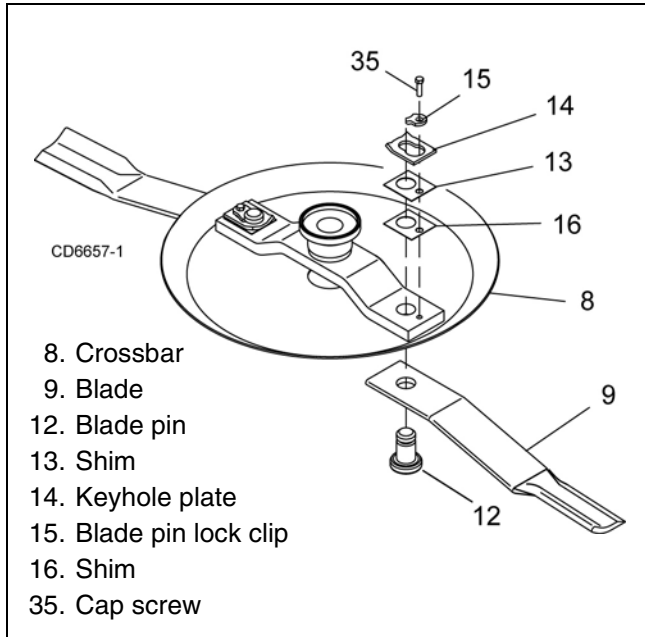

Figure 20. Blade Removal (BB84X Shown)

3. Remove cotter pin, castle nut, and washer from bottom of crossbar, Figure 21.

4. Attach a clevis (1) to each end of crossbar, using blade pins, spacers, keyhole plates, and blade pin clips.

5. Position tube assembly (5) with threaded nut toward crossbar for puller screw removal or down for hydraulic jack removal.

6. For removal with puller screw, attach tube (5) to each clevis with bolts (2) and nuts (3). Place pad (4) in nut and thread puller screw (6) into nut from bottom. Tighten until pad is solid against gearbox shaft. For best results, strike head of puller screw with a hammer while tightening with a wrench.

7. For removal with a jack, attach tube to each clevis with puller links (7), bolts (2), and nuts (3). Place jack on tube with end of jack pressing against gearbox shaft. Slowly apply force with jack.

NOTE: Hydraulic jack will not operate if tipped more than 90-degrees. Use care to prevent bending crossbar during removal.

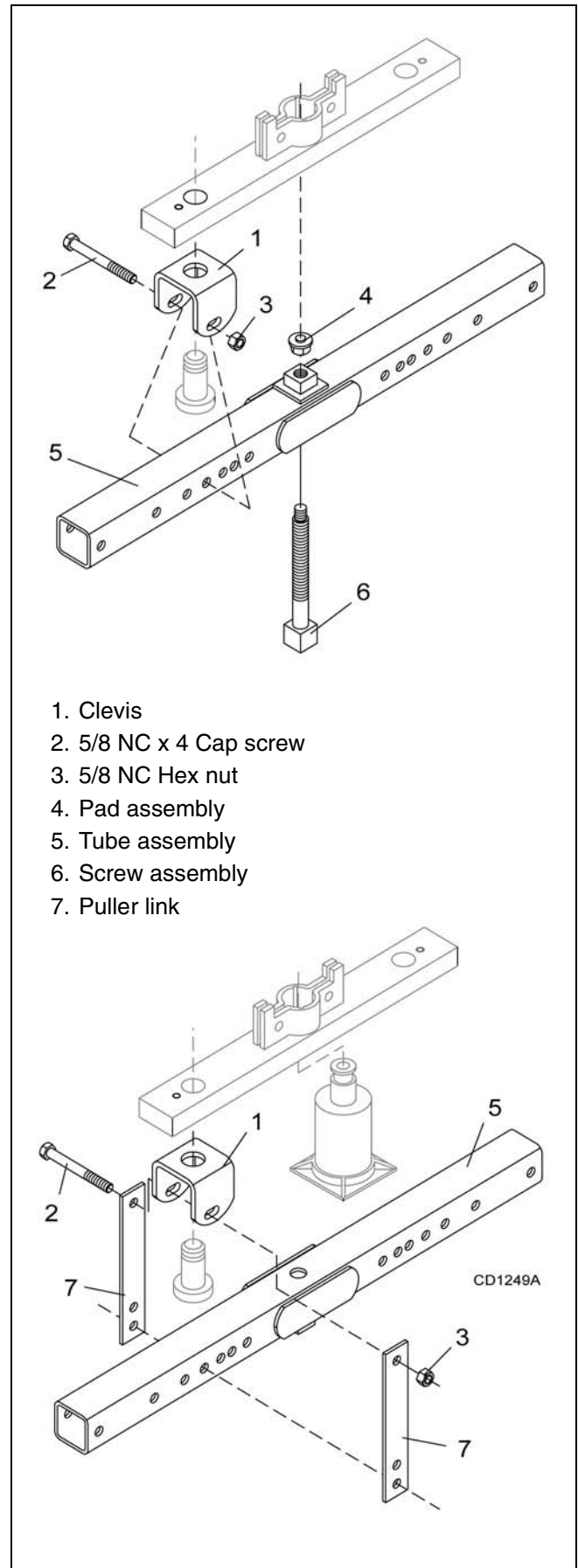

Figure 21. Crossbar Removal

CROSSBAR INSTALLATION

1. Using emery cloth (220 or finer), remove surface rust, Loctite® and foreign material from hub, splined gearbox, vertical shaft, and crossbar as shown in Figure 22.

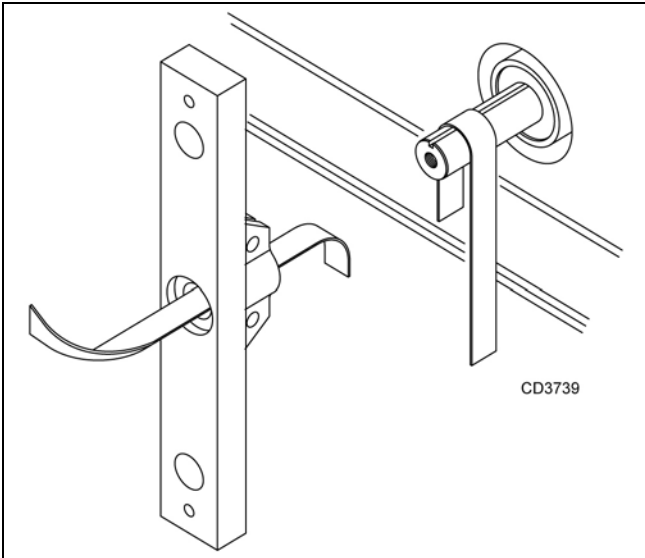

Figure 22

2. Install crossbar (2) on splined shaft. Install washer, castle nut, and cotter pin. Torque nut:

BB48X, BB60X, BB72X200 lbs-ft
 BB84X300 lbs-ft

3. Install the blades using existing hardware. Torque blade pin nut to 85 lbs-ft.

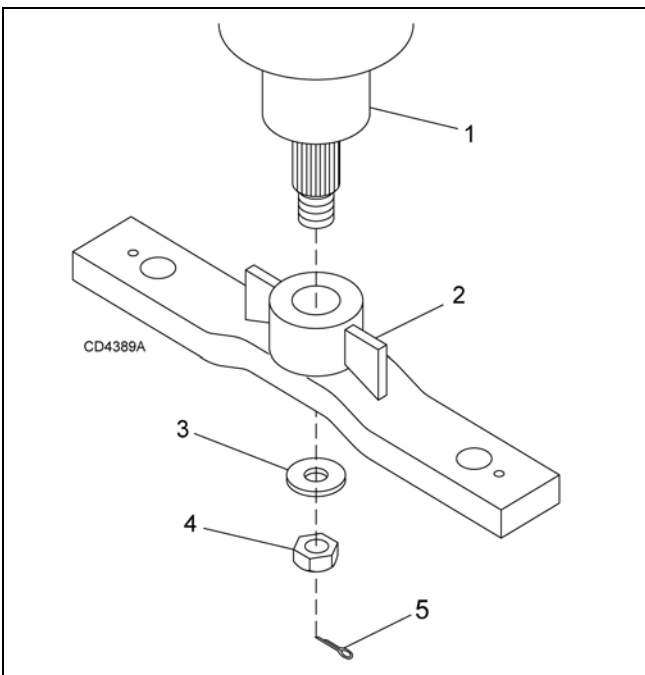

Figure 23

UNIVERSAL JOINT REPAIR

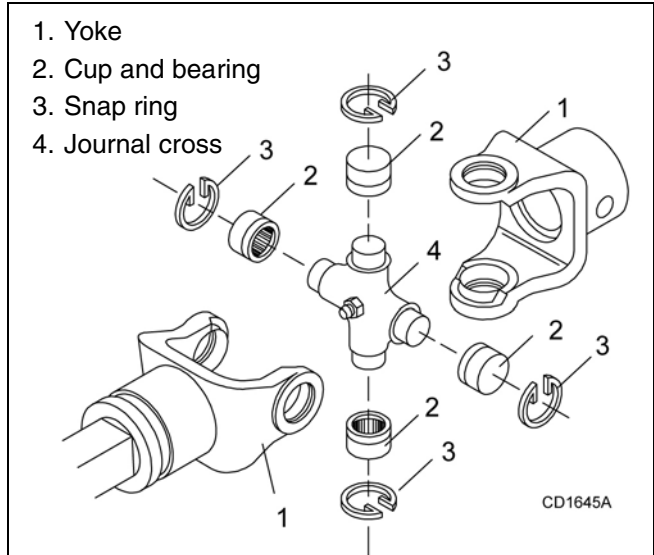

Figure 24. Universal Joint Parts Breakdown

U-Joint Disassembly

1. Remove external snap rings from yokes in four locations as shown in Figure 25.

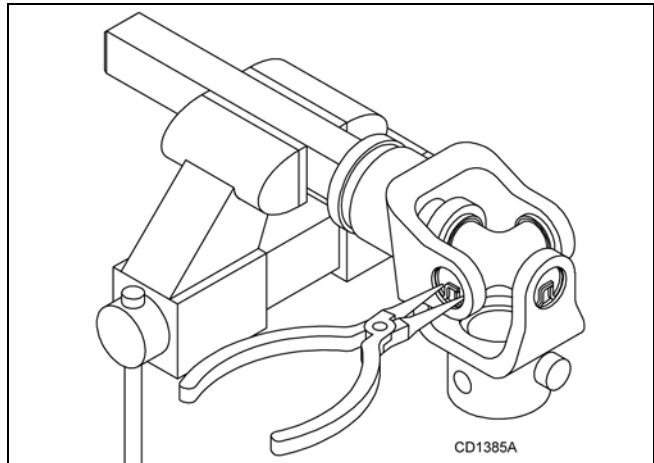

Figure 25. Remove Snap Ring

2. With snap rings removed, support drive in vise, hold yoke in hand and tap on yoke to drive cup up out of yoke. See Figure 26.

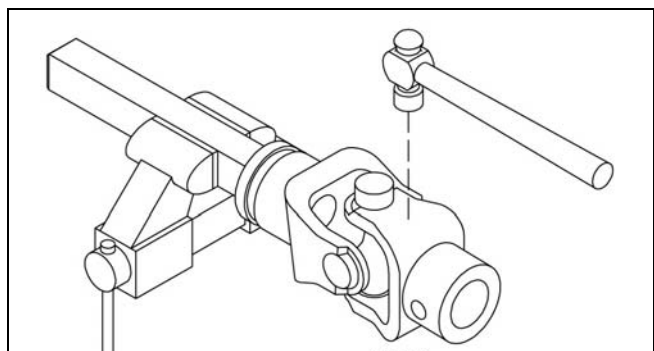

Figure 26. Remove Cups

3. Clamp cup in vise as shown in Figure 27 and tap on yoke to completely remove cup from yoke. Repeat Step 2 and Step 3 for opposite cup.

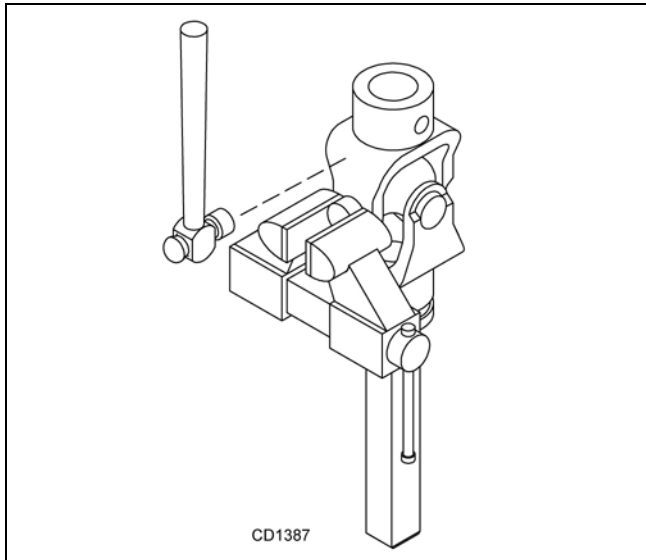

Figure 27. Remove Cups

4. Place universal cross in vise as shown in Figure 28 and tap on yoke to remove cup. Repeat Step 3 for final removal. Drive remaining cup out with a drift and hammer.

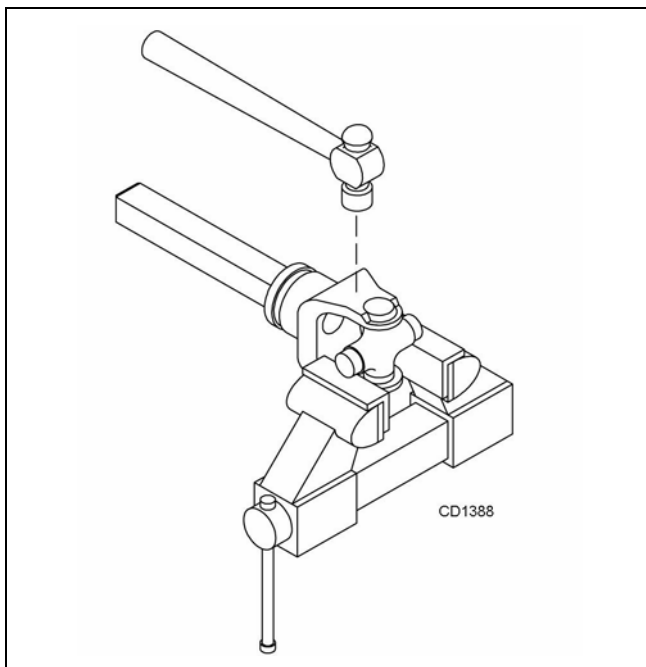

Figure 28. Remove Cups

U-Joint Assembly

1. Place seals securely on bearing cups. Insert cup into yoke from outside and press in with hand pressure as far as possible. Insert journal cross into bearing cup with grease fitting away from shaft. Be careful not to disturb needle bearings. Insert another bearing cup directly across from first cup and press in as far as possible with hand pressure.
2. Trap cups in vise and apply pressure. Be sure journal cross is started into bearings and continue pressure with vise, squeezing in as far as possible. Tapping the yoke will help.
3. Seat cups by placing a drift or socket (slightly smaller than the cup) on cup and rap with a hammer. See Figure 29. Install snap ring and repeat on opposite cup
4. Repeat Step 1 and Step 2 to install remaining cups in remaining yoke.
5. Move both yokes in all directions to check for free movement. If movement is restricted, rap on yokes sharply with a hammer to relieve any tension. Repeat until both yokes move in all directions without restriction.

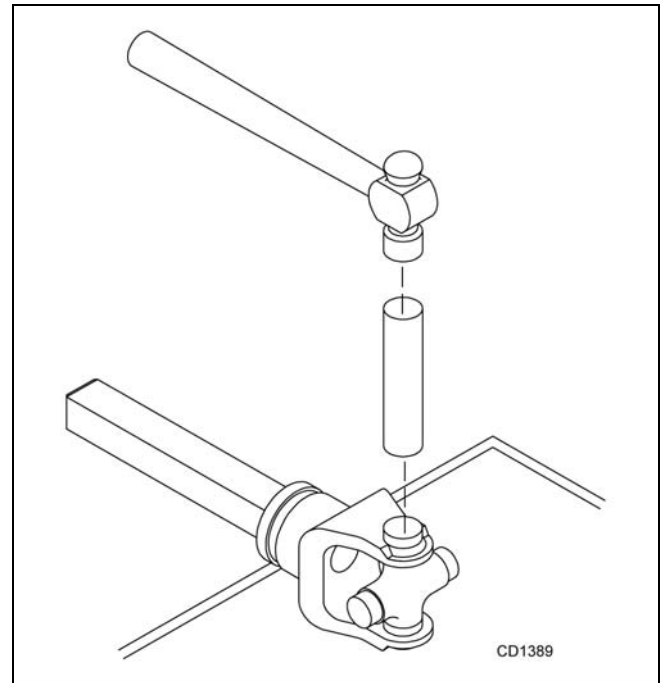

Figure 29. Install Cups

DEALER CHECK LISTS

PRE-DELIVERY CHECK LIST

(DEALER'S RESPONSIBILITY)

NOTICE

■ **Gearbox was not filled at the factory. It must be serviced before operating cutter. (See Fill Gearbox, page 41). Failure to service will result in damage to gearbox.**

Inspect cutter thoroughly after assembly to make sure it is set up properly before delivering it to the customer. The following check list is a reminder of points to inspect. Check off each item as it is found satisfactory, corrections are made, or services are performed.

- ___ Check all bolts to be sure they are properly torqued.
- ___ Check that all cotter pins are properly installed and secured.
- ___ Check that PTO shaft is properly installed.
- ___ Check that gearbox is properly serviced and seals are not leaking.
- ___ Check and grease all lubrication points as identified in, **Lubrication Information, page 18.**
- ___ Check that blades have been properly installed.

DELIVERY CHECK LIST

(DEALER'S RESPONSIBILITY)

- ___ Show customer how to make adjustments. Describe the options available for this cutter and explain their purpose.
- ___ Explain importance of lubrication to customer and point out lubrication points on cutter.
- ___ Present Operator's Manual and request that customer and all operators read it before operating equipment. Point out the manual safety rules, explain their meanings and emphasize the increased safety hazards that exist when safety rules are not followed.
- ___ Point out all guards and shielding. Explain their importance and the safety hazards that exist when not kept in place and in good condition.
- ___ For mounted units, add wheel weights, ballast in front tires, and/or front tractor weight to enhance front end stability. A minimum 20% of tractor and equipment gross weight must be on front tractor wheels. When adding weight to attain 20% of tractor and equipment weight on front tractor wheels, you must not exceed the ROPS weight certification. Weigh the tractor and equipment. Do not estimate!
- ___ Explain to customer that when equipment is transported on a road or highway, safety devices should be used to give adequate warning to operators of other vehicles.



NOTES

ASSEMBLY

DEALER SET-UP INSTRUCTIONS

Assembly of this cutter is the responsibility of the Woods dealer. It should be delivered to the owner completely assembled, lubricated, and adjusted for normal cutting conditions.

The cutter is shipped partially assembled. Assembly will be easier if aligned and loosely assembled before tightening hardware. Recommended torque values for hardware are located in the **Bolt Torque Chart, page 56**.

Complete **Dealer Check Lists, page 34** when you have completed the assembly.

! DANGER

■ Full chain, rubber, or steel band shielding must be installed when operating in populated areas or other areas where thrown objects could injure people or damage property.

- If this machine is not equipped with full chain, rubber, or steel band shielding, operation must

be stopped when anyone comes within 300 feet (92 m).

- This shielding is designed to reduce the risk of thrown objects. The mower deck and protective devices cannot prevent all objects from escaping the blade enclosure in every mowing condition. It is possible for objects to ricochet and escape, traveling as much as 300 feet (92 m).

! WARNING

- Make sure attachment is properly secured, adjusted, and in good operating condition.

! CAUTION

- Always wear relatively tight and belted clothing to avoid getting caught in moving parts. Wear sturdy, rough-soled work shoes and protective equipment for eyes, hair, hands, hearing, and head; and respirator or filter mask where appropriate.

1. Mounting pin hardware
2. A-Frame bar
3. Upper mounting hardware (under clutch shield)
4. Diagonal brace
- 5A. Diagonal brace bar mounting hole
- 5B. Tailwheel pivot hole
6. Tailwheel bracket
7. PTO Hanger
9. Tailwheel
10. Height adjustment
12. Bag of hardware
13. Driveline (Shear bolt)
14. Clutch shield

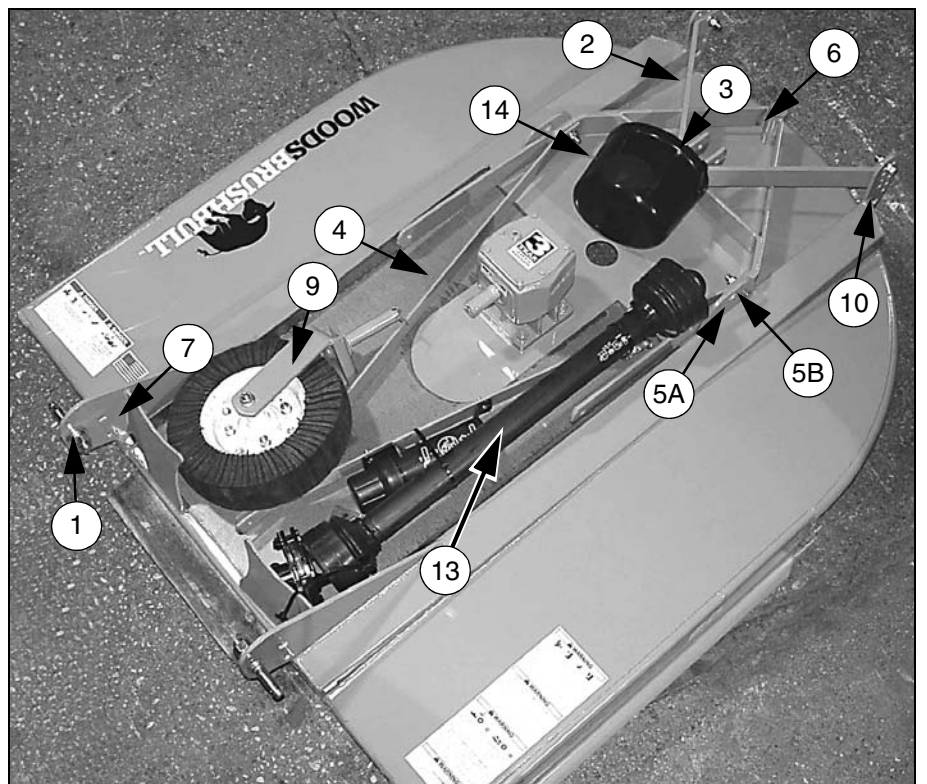

Figure 30. BB48X Shipping Configuration

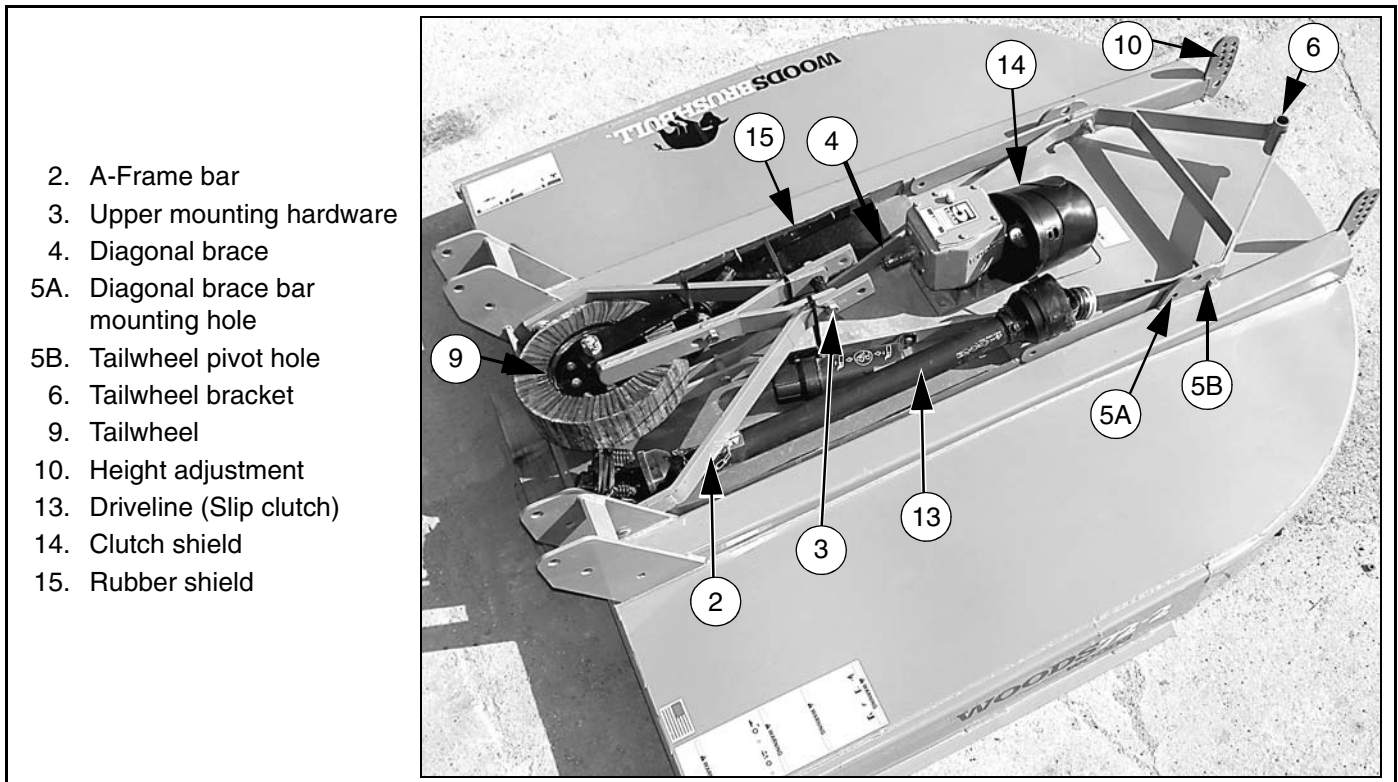

Figure 31. BB60X, BB72X & BB84X Shipping Configuration

DISASSEMBLE SHIPPING UNIT
(FIGURE 32)

Remove all parts that are wired and strapped to cutter.

Remove cap screws (13) and flange lock nuts (14) that are securing A-frame bars (2) to the cutting height adjustment holes (10).

Remove cap screws (13) and flange lock nuts (14) that are securing tailwheel bracket (6) and diagonal brace bars (4) to cutter.

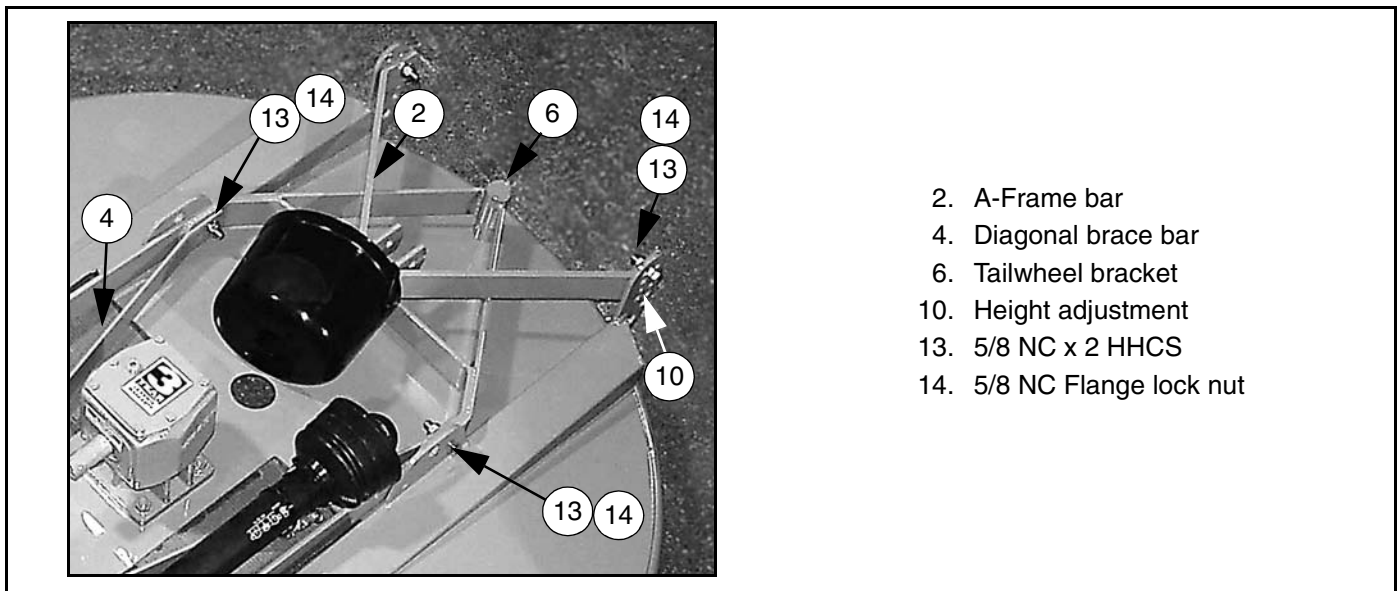

Figure 32. Shipping Unit Disassembly
(BB48X Shown)

- 2. A-Frame bar
- 4. Diagonal brace bar
- 6. Tailwheel bracket
- 10. Height adjustment
- 13. 5/8 NC x 2 HHCS
- 14. 5/8 NC Flange lock nut

INSTALL A-FRAME

BB48X Cutters: Attach A-frame bars (6) to the inside of front mast plates. Secure into position using carriage bolts (23), sleeves (19), flat washers (48), and flange lock nuts (12).

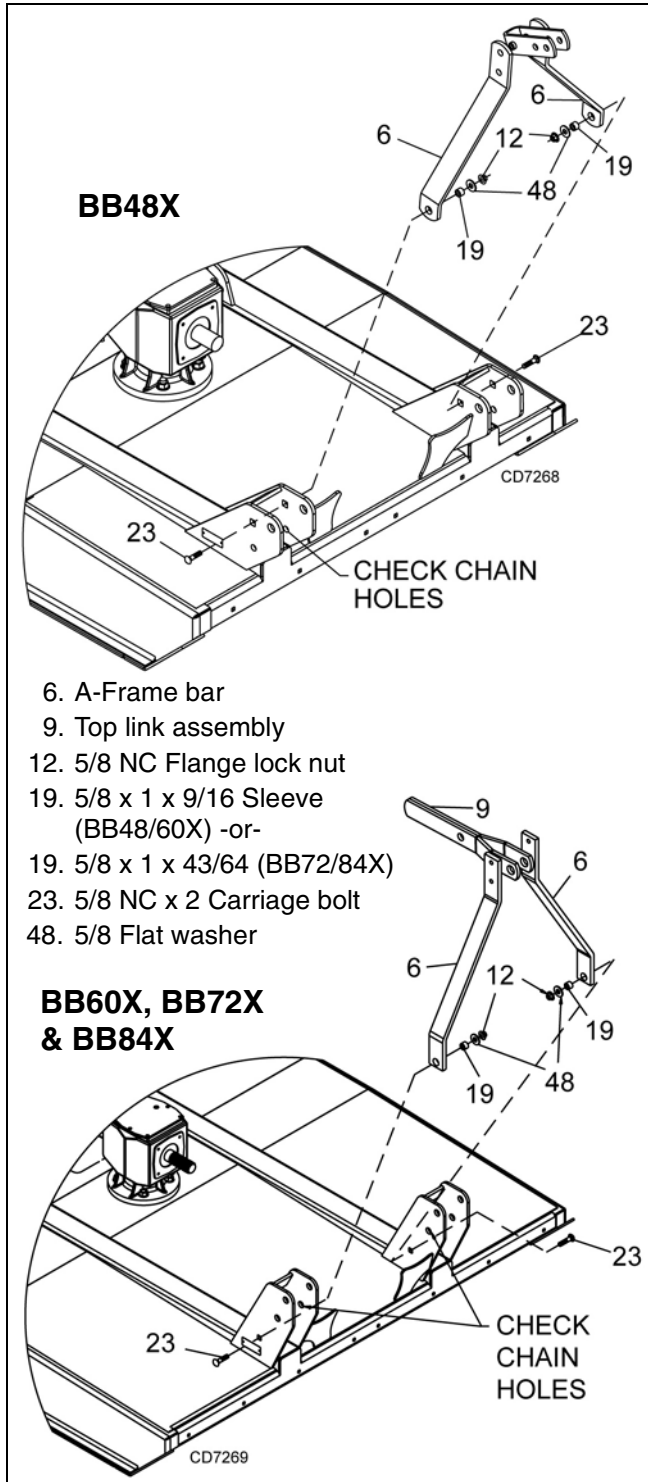

Figure 33. A-Frame Assembly

BB60X, BB72X & BB84X Cutters: A-frame bars (6) are already attached to the front mast plates. Rotate up for connection to diagonal brace bars.

INSTALL A-FRAME TO DIAGONAL BRACE BARS

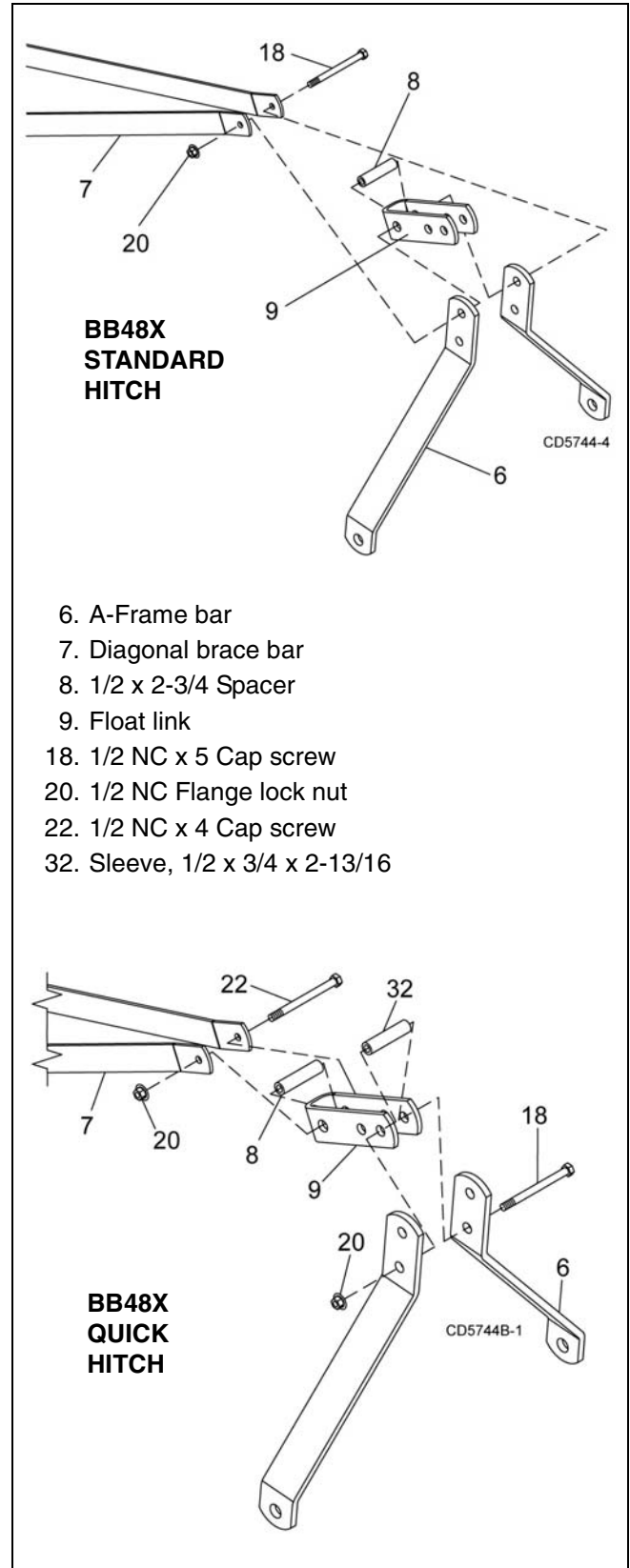

Figure 34. Diagonal Brace Bars to A-Frame Connection - BB48X Only

INSTALL TAILWHEEL

1. Attach tailwheel bracket (6) to cutter at the tailwheel pivot holes (5B) using cap screw (13) and flange lock nut (14) previously removed.

NOTE: Make sure grease fitting on tube is on top when installing tailwheel.

2. Select desired height adjustment holes (10), and secure tailwheel bracket with cap screws (13) and flange lock nuts (14). Cutting height adjustment will be necessary when cutter is fully assembled. See page 16.
3. Raise rear of cutter and insert tailwheel assembly (9) into tailwheel bracket (6). Secure with washer (37) and spiral pin (28).
4. Place diagonal brace bars (4) on the inside of frame rails and attach to diagonal brace mounting holes (5A). Secure using cap screws (13) and flange lock nuts (14).

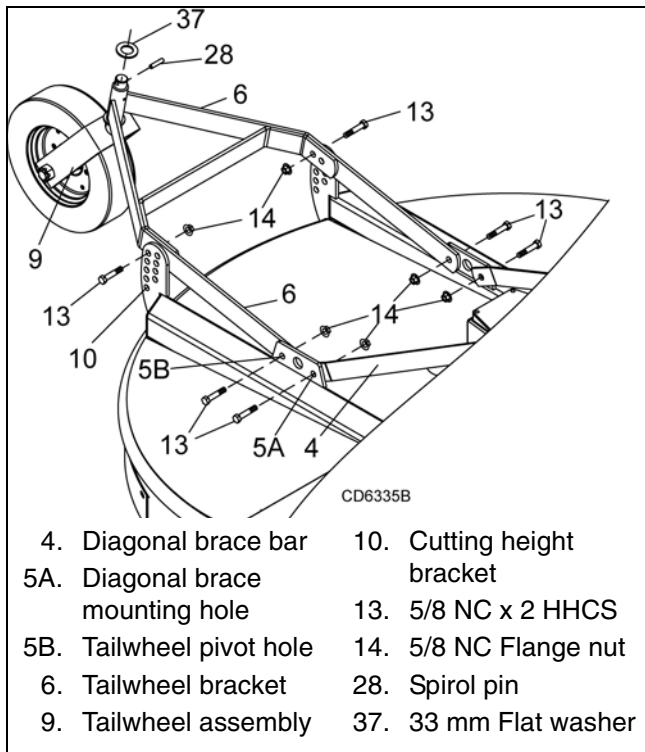

Figure 35. Tailwheel Installation

INSTALL DUAL TAILWHEEL BB84XD (OPTIONAL)

1. Attach dual tailwheel (1) to main frame (2) using position 5B and desired height adjustment holes as shown in Figure 36.
2. Secure with cap screws (3) and hex nuts (4).
3. Torque hardware to 175 lbs-ft.

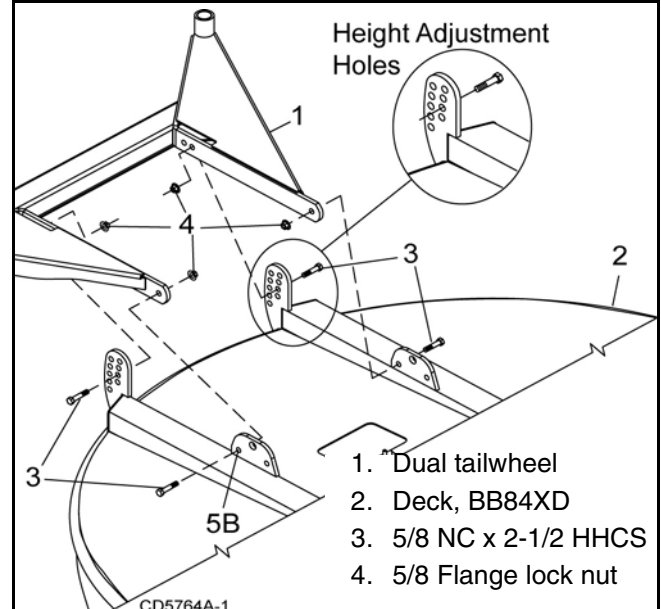

Figure 36. Dual Tailwheel Installation

BB48X Standard Hitch Set-Up

1. Remove cap screw (18), upper Figure 34, and flange lock nut (20) from top hole on A-frame bars. Leave spacer (8) and float link (9) together.
2. Position diagonal brace bars (7) on the outside of A-frame bars (6).
3. Align diagonal brace bars with top hole in A-frame bars, float link, and spacer. Secure with cap screw (18) and flange lock nut (20) that were previously removed.

BB48X Quick Hitch Set-Up

An optional Quick Hitch attachment may be used on this cutter. Install A-frame as shown (Figure 34, bottom).

BB60X, BB72X & BB84X Standard & Quick Hitch Set-Up

1. Leave A-frame and top link attached together.
2. Remove bolt (60), spacer (10) and nut (12) from front hole in brace bar (7).
3. Assemble top link to brace bar with previous hardware as shown in Figure 37.

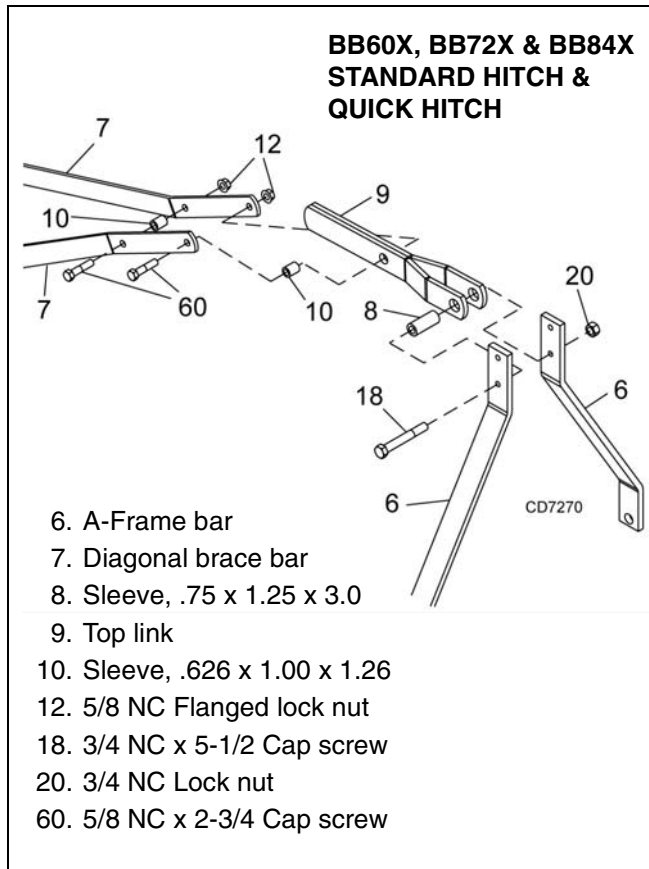

Figure 37. Diagonal Brace Bars to A-Frame Connection - BB60X, BB72X & BB84X

INSTALL DRIVELINE

On BB48X or BB60X, select either the standard shear bolt or optional slip clutch driveline.

Shear Bolt Driveline - BB48X & BB60X Only

NOTICE

■ A grade 2 bolt must be used for the shear bolt to provide gearbox protection.

1. Remove rear drive shield (1) from driveline.
2. Position clutch shield (5) against gearbox. Secure using cap screw (7), lock washers (8), and flat washers (9). Torque hardware to 12 lbs-ft.

3. To prevent seal damage, carefully push driveline onto gearbox input shaft until it contacts the gearbox housing.
4. Place retaining ring (6) in slot on input shaft and snap into place.
5. Align the holes in the driveline yoke and gearbox input shaft. Install and tighten shear bolt (4) and nut (3).
6. Install rear drive shield to driveline.
7. Lubricate rear driveline half and install front driveline half.
8. Attach tether chain to diagonal brace bar.

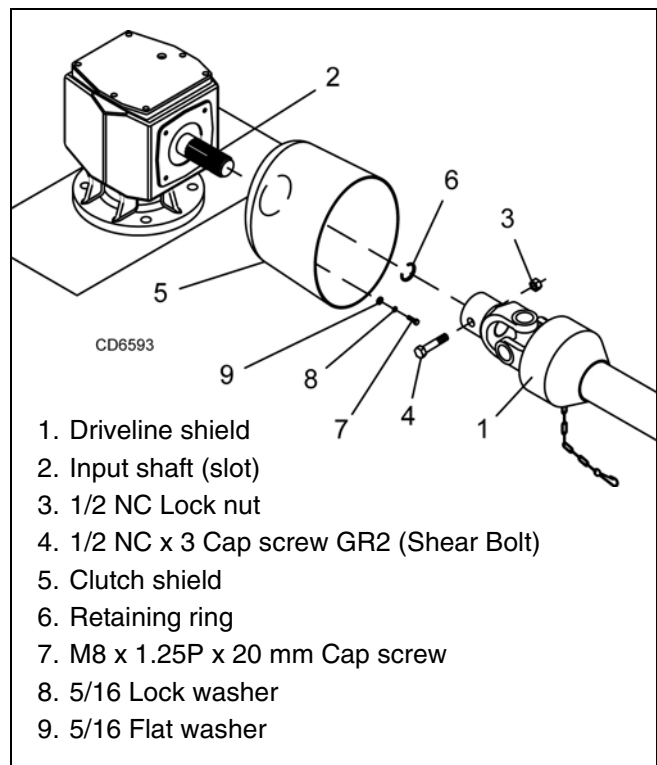

Figure 38. Shear Bolt Driveline Assembly (BB48X & BB60X Standard)

Driveline Slip Clutch - Optional on BB48X & BB60X

NOTICE

■ A grade 8 bolt must be used to attach clutch driveline to gearbox.

A new slip clutch, or one that has been in storage over the winter, may seize.

1. Before operating slip clutch, make sure it will slip. Refer to **Slip Clutch Adjustment, page 20**.
2. Position clutch shield (3) against gearbox. Secure using cap screw (4), lock washers (5), and flat washers (6). Torque hardware to 12 lbs-ft.

3. Install driveline onto gearbox input shaft and secure with bolt (1) and nut (2).
4. Secure driveline with bolt (1) and nut (2).
5. Lubricate rear driveline half and install front driveline half.
6. Attach tether chain to diagonal brace bar.

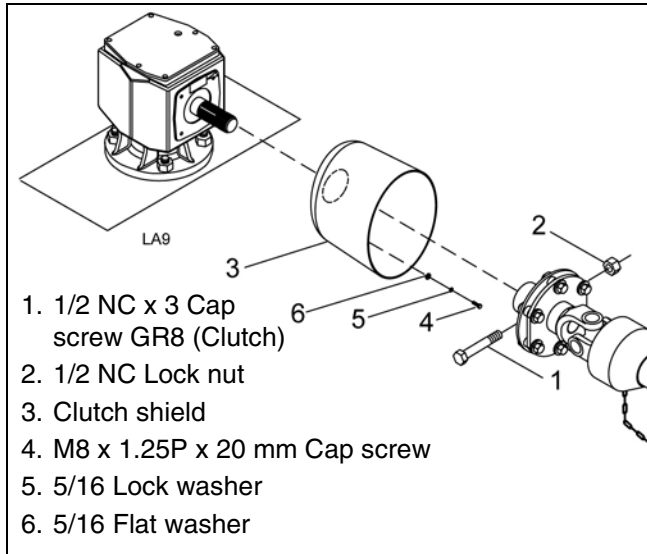

Figure 39. Slip Clutch Driveline Assembly
(BB48X & BB60X Optional)
(BB72X & BB84X Standard)

Driveline Slip Clutch - BB72X and BB84X

1. Before operating slip clutch, make sure it will slip. Refer to **Slip Clutch Adjustment**, page 20.
2. Position clutch shield (3) against gearbox. Secure using cap screw (4), lock washers (5), and flat washers (6). Torque hardware to 12 lbs-ft.
3. Install driveline onto gearbox input shaft and secure with bolt (1) and nut (2).
4. Secure drive by releasing lock collar slide onto the gearbox shaft and release lock collar when balls are seated into groove. Pull on drive to insure drive is secure.

INSTALL SAFETY SHIELDING

Chain Shielding (Optional)

⚠ DANGER

■ Full chain, rubber, or steel band shielding must be installed when operating in populated areas or other areas where thrown objects could injure people or damage property.

- If this machine is not equipped with full chain, rubber, or steel band shielding, operation must be stopped when anyone comes within 300 feet (92 m).
- This shielding is designed to reduce the risk of thrown objects. The mower deck and protective devices cannot prevent all objects from escaping the blade enclosure in every mowing condition. It is possible for objects to ricochet and escape, traveling as much as 300 feet (92 m).

The optional chain shielding assemblies are ready for installation when you receive them.

1. Refer to **Front & Rear Chain Shielding**, page 55, and attach as shown by inserting the bolts from inside the cutter frame out through the shielding.
2. Install hardware as shown in the parts drawing.

Rubber Deflector (Standard)

Attach rubber deflector (1) and link (2) to front of cutter using carriage bolts (3) and flange lock nuts (4).

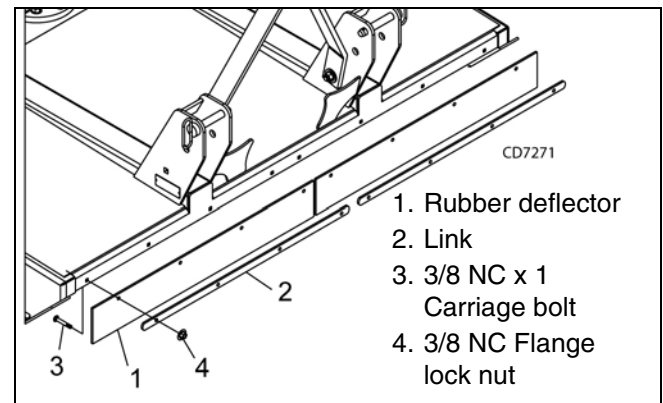

Figure 40. Rubber Deflector Installation

FILL GEARBOX

NOTICE

■ Gearbox is not filled at the factory. Prior to delivery to customer, make sure gearbox is filled only half-full with 80W or 90W API GL-4 or GL-5 gear lube. Use side plug to remove any excess oil.

1. Remove solid plug and discard.
2. Make sure vent plug hole is clear.
3. Fill gearbox until oil runs out the side plug on gearbox. Use a high quality gear oil with a viscosity index of 80W or 90W and an API service rating of GL-4 or GL-5.
4. Install vent plug. Use pipe sealant or thread tape on threads. Plug is shipped in the manual tube.

INSTALL OPTIONAL CHECK CHAINS

Check chains are used to carry the front of cutter at a set height.

1. Thread check chains (3) through check chain bracket (2).
2. Attach lower end of check chain (3) to mast plate (9 or 11) with bolt (6), washer (7), and nut (8).
3. Attach keyhole brackets (2) to each side of tractor top link bracket (10) with bolt (4) and nut (5).
4. Insert check chains through keyhole brackets and set cutter height.

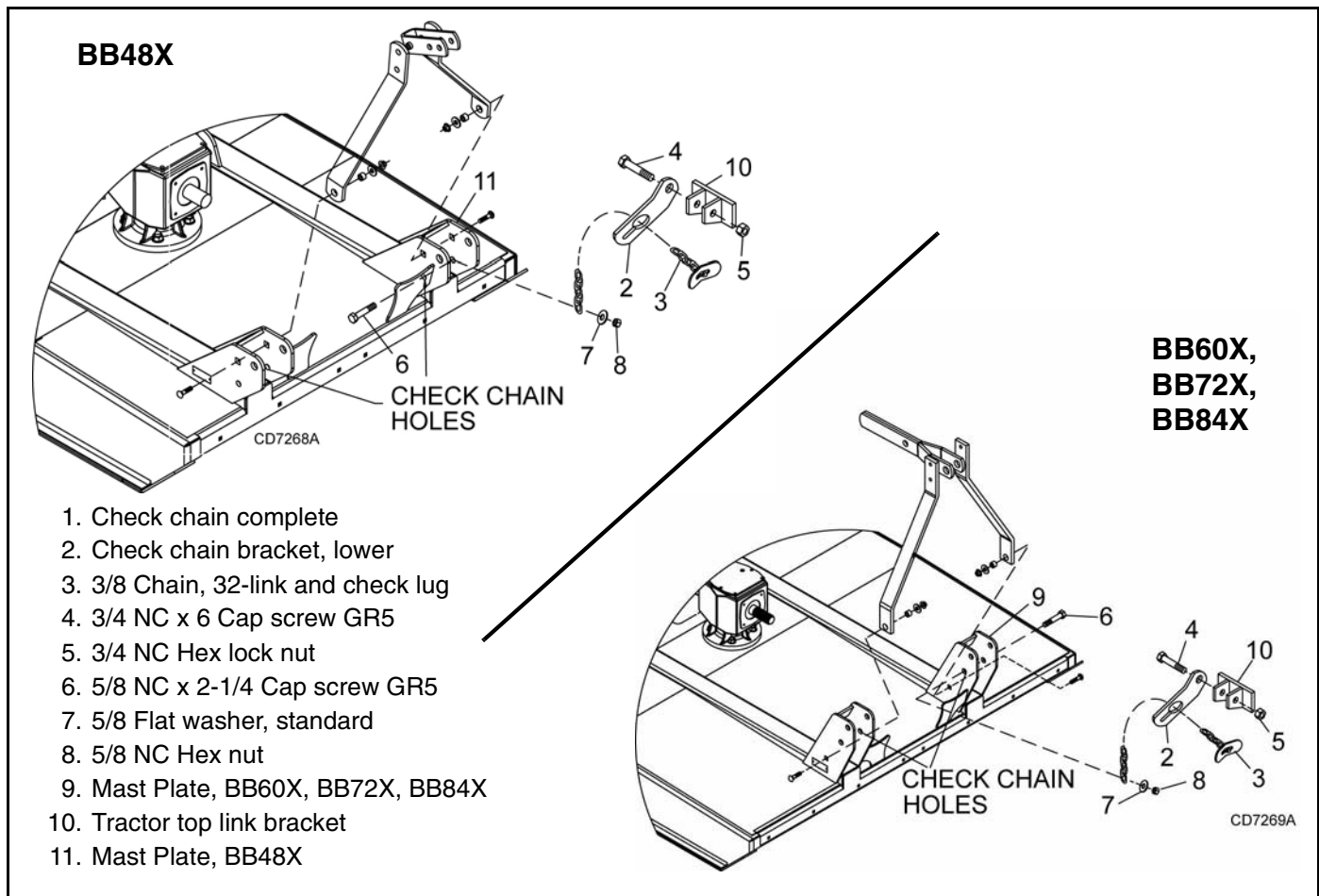
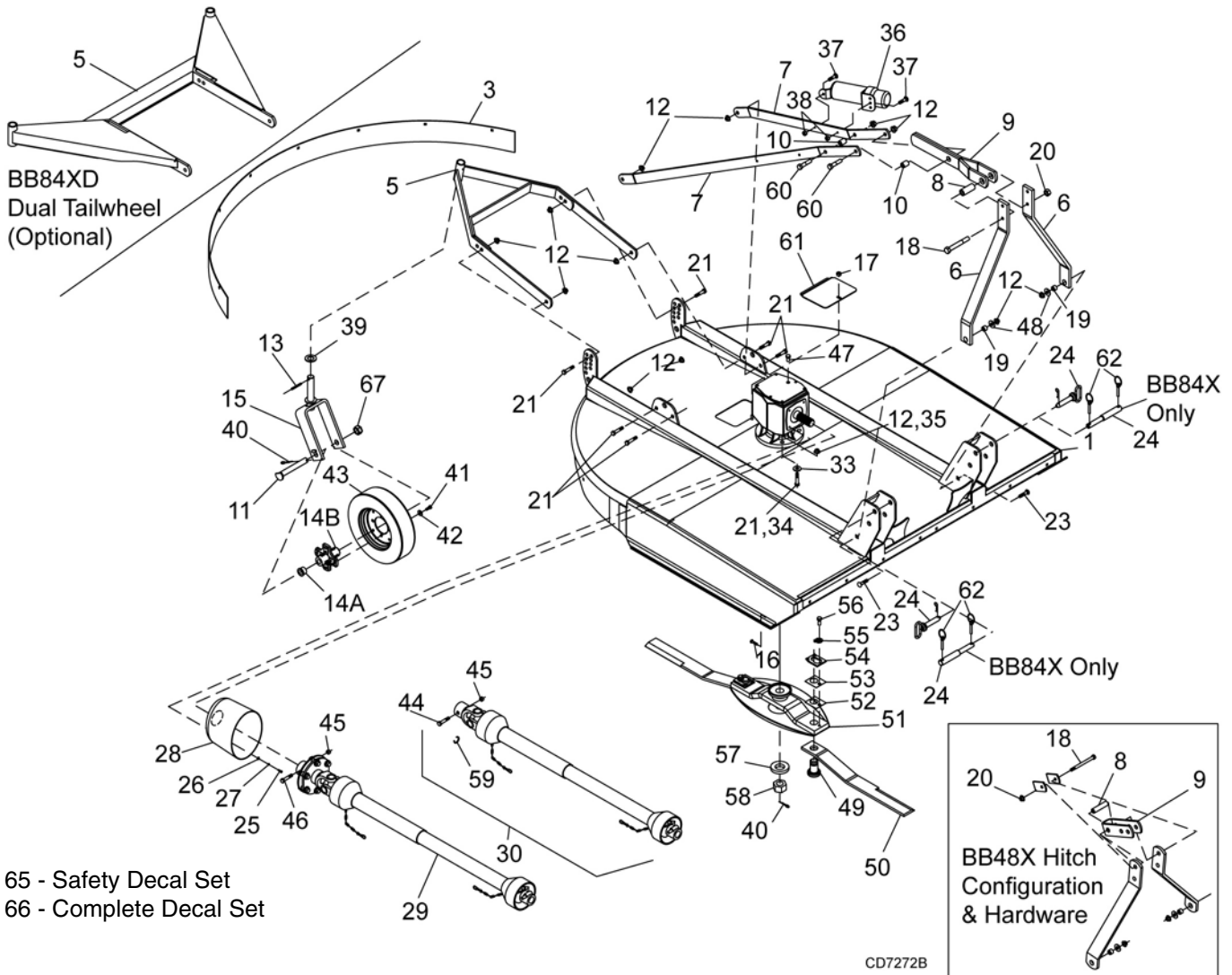

Figure 41. Check Chain Installation

BRUSHBULL™ **Rotary Cutters:** **BB48X, BB60X, BB72X, BB84X**

BRUSHBULL™ STANDARD-DUTY MAIN ASSEMBLY	44-45
GEARBOX ASSEMBLY (FLAT-TOP)	46-47
GEARBOX ASSEMBLY (CAST/CROWN TOP).....	48
CHECK CHAIN ASSEMBLY (OPTIONAL)	47
DRIVELINES:	
BB48X COMER STANDARD DRIVELINE	49
BB60X COMER STANDARD DRIVELINE	50
BB48X & BB60X COMER SLIP CLUTCH DRIVELINE (OPTIONAL)	51
BB72X COMER SLIP CLUTCH DRIVELINE	52
BB84X COMER SLIP CLUTCH DRIVELINE	53
BB84X WALTERSCHEID SLIP CLUTCH DRIVELINE	54
FRONT RUBBER SHIELDING (STANDARD)	55
REAR BAND SHIELDING (STANDARD).....	44
FRONT & REAR CHAIN SHIELDING (OPTIONAL)	55

BRUSHBULL STANDARD-DUTY MAIN ASSEMBLY BB48X, BB60X, BB72X & BB84X (BB84X SHOWN)



REF	PART	QTY	DESCRIPTION
3	57236	1	Rear band - BB48X
3	57210	1	Rear band - BB60X
3	57183	1	Rear band - BB72X
3	57184	1	Rear band - BB84X
5	57162	1	Tailwheel assembly
5	1030529	1	Dual tailwheel assembly (BB84XD) (optional)
6	1021569	2	A-Frame bar BB48X
6	1023059	2	A-Frame bar BB60X
6	1021556	2	A-Frame bar BB72X
6	1024123	2	A-Frame bar BB84X

REF	PART	QTY	DESCRIPTION
7	57239	2	Diagonal brace BB48X
7	1023060	2	Diagonal brace BB60X
7	1021559	2	Diagonal brace BB72X
7	1023044	2	Diagonal brace BB84X
8	64814	1	Spacer 1/2 x 2-3/4 BB48X
8	27140	1	Sleeve, 3/4 x 1-1/4 x 3 BB60X, BB72X, BB84X
9	15321	1	Link, bent .38 x 2.5 x 9.13 BB48X
9	1021560	2	Top link BB60X, BB72X, BB84X
10	66661	2	Sleeve, .626 x 1.00 x 1.26 BB60X, BB72X, BB84X
11	1030523	1	M24 x 2 Axle bolt

44 Parts

(Rev. 4/20/2011)
MAN0632 (5/15/2007)

BB48X, BB60X, BB72X & BB84X MAIN ASSEMBLY PARTS LIST

REF	PART	QTY	DESCRIPTION	REF	PART	QTY	DESCRIPTION
12	19025	14	5/8 NC Flange lock nut	42	*	4	1/2 Flat washer
13	40775	1	Spirol pin 10 mm x 65 mm	43	4676	1	4 x 15 Notat tire & rim
14A	1030524	2	Bushing, flanged .984 x 1.378 x .98	44	15349	1	1/2 NC x 3 Shear bolt GR2
14B	1030522	1	Hub, 4 bolt 4 x 8	45	765 *	2	1/2 NC Lock nut
15	1028815	1	Tailwheel clevis	46	1001315	1	Bolt & nut, M12 x 1.25 x 65 - BB72X Clutch
16	6697 *	8	3/8 NC x 1 Carriage bolt GR5	47	57076	1	Vent plug, (See Gearbox, page 46) BB84X; BB48X, BB60X, BB72X S/N 1159928 and Before (Flat Top Gearbox)
17	14350	9	3/8 NC Flange lock nut	47	1011780	1	Vent plug, (See Gearbox, page 48) BB48X, BB60X, BB72X S/N 1159929 and After (Cast/Crown Top Gearbox)
18	23479 *	1	1/2 NC x 5 Cap screw GR5 BB48X	48	692 *	2	5/8 Flat washer
18	29315	1	3/4 NC x 5-1/2 Cap screw GR5 BB60X, B72X, BB84X	49	15803	2	Blade pin - BB48X & BB60X
19	1791	2	Sleeve, 5/8 x 1 x 9/16 HT BB48X & BB60X	49	1009199	2	Blade pin - BB72X & BB84X
19	67222	2	Sleeve, 5/8 x 1 x 43/64 HT BB72X & BB84X	50	30310KT	1	Blade 3/8 x 3 x 16 CCW - BB48X
20	11900 NS	2	1/2 NC Flange lock nut (BB48X Quick Hitch)	50	15326KT	1	Blade 3/8 x 3 x 20.50 CCW - BB60X
20	2371	1	3/4 NC Lock nut ZP (BB60X, BB72X, BB84X)	50	57189KT	1	Blade 1/2 x 3 x 26.5 CCW BB72X & BB84X
21	902 *	10	5/8 x 2 Cap screw GR5	51	1021562		Crossbar asy BB48X, BB60X, BB72X - S/N 1159928 and Before (Flat Top Gearbox)
21	941 *	4	5/8 NC x 2-1/2 HHCS GR5 (4 for BB84XD)	51	1032590		Crossbar asy BB48X, BB60X, BB72X - S/N 1159929 and After (if equipped with Cast/Crown Top Gearbox)
22	10380*NS	1	1/2 NC x 4 Cap screw GR5 (BB48X Quick Hitch)	51	1021571	1	Crossbar asy BB84X
23	2855 *	2	5/8 x 2 Carriage bolt GR5	52	13946	2	20 GA 1-1/2 Blade shim
24	1023033	2	Hitch pin .875 x 5.02 BB48X, BB60X, BB72X	53	10520	2	18 GA 1-1/2 Blade shim
24	1026542	2	Step pin, Cat. 1 or 2 BB84X	54	32603	2	Keyhole plate
25	24801	4	M8 x 1.25P x 20 mm Cap screw	55	32604	2	Blade pin lock clip, special
26	35155 *	4	5/16 Flat washer	56	6100 *	2	1/2 NC x 1-1/4 GR5 Cap screw
27	2472 *	4	5/16 Lock washer	57	20893	1	Washer, 25 x 44 x 4 mm (BB48X, BB60X, BB72X)
28	1002048	1	Clutch shield, 100 x 143 mm BC	57	39322	1	Washer, 31 x 56 x 4 mm BB84X
29	1020901	1	Complete slip clutch drive asy - BB72X (pg 52) -or-	58	20892	1	Castle nut metric, M24 x 2 BB48X, BB60X, BB84X
29	1024144	1	Complete slip clutch drive asy - BB84X (pg 53)	58	39323	1	Castle nut metric, M30 x 2 BB84X
30	1009509	1	Complete shear pin drive asy - BB48X (pg 49) -or-	59	15345	1	Retaining ring, .05 x 1.38
30	1009510	1	Complete shear pin drive asy - BB60X (pg 50) -or-	60	986 *	2	5/8 NC x 2-3/4 Cap Screw GR5 - BB60X, BB72X, BB84X
30	1020900 NS	1	BB48X & BB60X Optional slip clutch drive (page 51)	61	57050	1	Bent link, .14 x 9.0 x 7.84
32	33657 NS	1	Sleeve, 1/2 x 3/4 x 2-13/16 (BB48X Quick Hitch)	62	27542	4	7/16 x 11/32 Klik pin HT
33	57817	4	5/8 Flat washer, hardened BB48X, BB60X, BB72X	65	15358	1	Safety decal set
33	57798	4	3/4 Flat washer, hardened BB84X	66	1000624	1	Complete decal set
34	30068	4	3/4 NC x 2-1/2 Cap screw GR5 BB84X	67	1032105	1	Nut slotted M24x2.0P
35	302207	4	3/4 NC Flange lock nut				
36	1003828	1	Manual tube		*		Standard hardware; obtain locally
37	24409 *	2	5/16 NC x 1 Carriage bolt		NS		Not Shown
38	4529 *	2	5/16 NC Hex nut				
39	*	1	Washer, 33 mm x 56 mm x 4 mm				
40	*	2	Cotter Pin				
41	300300	4	1/2 NC x 1 HHCS GR5				

GEARBOX ASSEMBLY - (FLAT TOP)

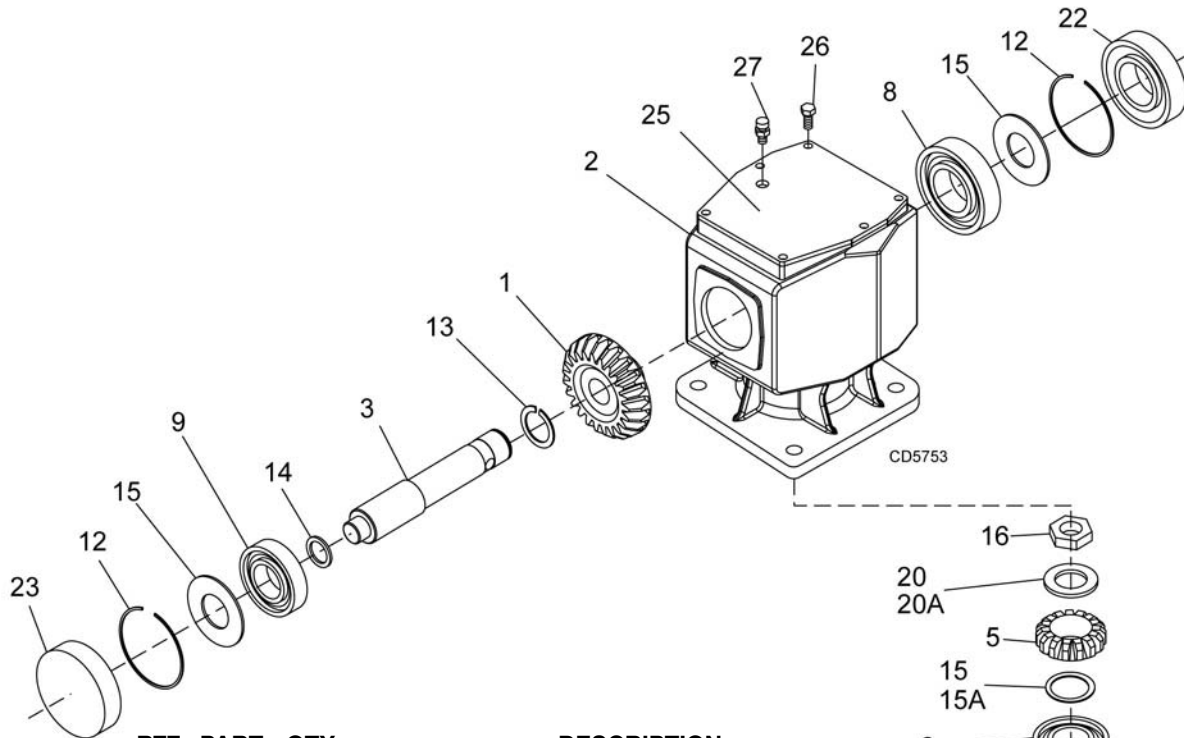

REF	PART	QTY	DESCRIPTION
A	58800	1	Gearbox repair asy (BB48X) - S/N 1159928 and Below
A	58801	1	Gearbox repair asy (BB60X) - S/N 1159928 and Below
A	58802	1	Gearbox repair asy (BB72X) - S/N 1159928 and Below
A	58803	1	Gearbox repair asy (BB84X)
1	57458	1	Gear, crown 25T (BB48X)
1	57459	1	Gear, crown 24T (BB60X)
1	57460	1	Gear, crown 22T (BB72X)
1	39424	1	Gear, crown 19T (BB84X)
2	NSS	1	Gearbox housing
3	57464	1	Input shaft 1-3/8 smooth shaft (BB48X & BB60X)
3	57465	1	Input shaft 1-3/8 - 6 spline (BB72X)
3	57147	1	Input shaft 1-3/8 - 6 spline (BB84X)
4	57489	1	Output shaft (BB48X & BB60X)
4	57490	1	Output shaft (BB72X)
4	57191	1	Output shaft (BB84X)
5	57491	1	Gear, pinion 13T M5.3 (BB48X)
5	57497	1	Gear, pinion 14T M5.3 (BB60X)
5	57498	1	Gear, pinion 15T M5.7 (BB72X)
5	39418	1	Gear, pinion 15T M6.5 (BB84X)
6	57476	1	Bearing cup & cone (BB48X & BB60X)
6	39257	1	Bearing cup & cone (BB72X)
6	39263	1	Bearing cup & cone (BB84X)
7	57478	1	Bearing cup & cone (BB48X, BB60X, BB72X)
7	39263	1	Bearing cup & cone (BB84X)
8	57462	1	Bearing cup & cone

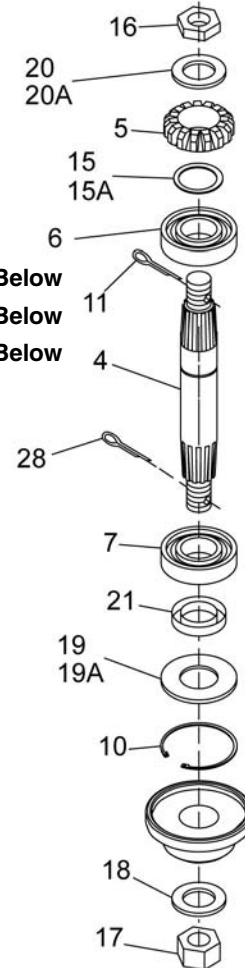

(Continued on next page)

GEARBOX ASSEMBLY PARTS LIST (Continued)

REF	PART	QTY	DESCRIPTION	REF	PART	QTY	DESCRIPTION
9	20890	1	Bearing-Ball	20A	57094	1	Shim kit 44 x 30.3 x 1 (BB84X)
10	20897	1	Ring retainer 81mm internal (BB48X, BB60X, BB72X)	20	57473	1	Flat washer 21 x 37 x 3 (BB48X & BB60X)
11	*	1	Cotter pin	20	57474	1	Flat washer 25 x 48 x 2.5 (BB72X)
12	57466	2	Snap ring	21	20900	1	Seal, metric 40 x 80 x 12 (BB48X, BB60X, BB72X)
13	20895	1	Snap ring (BB48X, BB60X, BB72X)	21	39289	1	Seal, 50 x 90 x 10 (BB84X)
14	57373	1	Spacer 35.3 x 48 x 2.5 (BB48X, BB60X, BB72X)	22	57463	1	Oil seal 35 x 72 x 10
15	57328	2	Gearbox shim kit	23	57374	1	Oil cap
15A	57471	1	Shim kit 50.3 x 70.3 (BB84X)	25	57375	1	Top cover (BB48X & 60X)
16	57468	1	Castle nut (BB48X & BB60X)	25	57376	1	Top cover (BB72X)
16	57469	1	Castle nut (BB72X)	25	57139	1	Top cover (BB84X)
16	39261	1	Castle nut (BB84X)	26	*	6	M8 x 16 Hex head cap screw CL8.8 (BB48X, BB60X, BB72X)
17	20892	1	Castle nut metric M24 x 2 (BB48X, BB60X, BB72X)	26	*	6	M8 x 14 Hex head cap screw CL8.8 (BB84X)
17	39323	1	Castle nut metric M30 x 2 (BB84X)	27	57076	1	Vent plug 1/2 NPT
18	20893	1	Washer 25 x 44 x 4 mm (BB48X, BB60X, BB72X)	28	*	1	Cotter pin
18	39322	1	Washer 31 x 56 x 4 mm (BB84X)				NSS Not Serviced Separately
19	20888	1	Protective washer (BB48X, BB60X, BB72X)				* Standard hardware, obtain locally
19A	57338	1	Screen protection (BB84X)				

CHECK CHAIN ASSEMBLY (OPTIONAL)

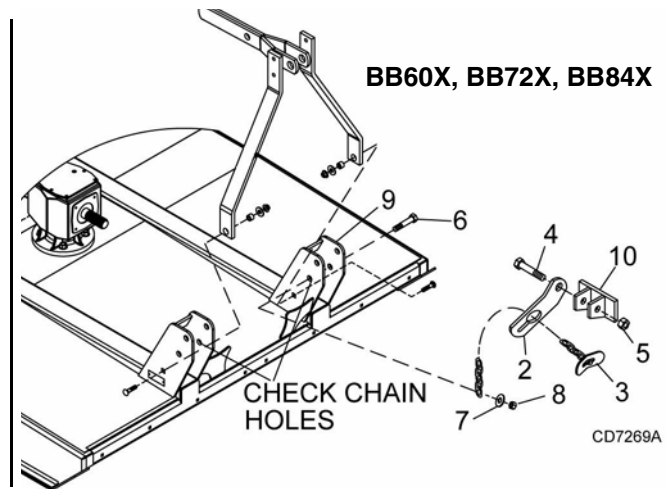
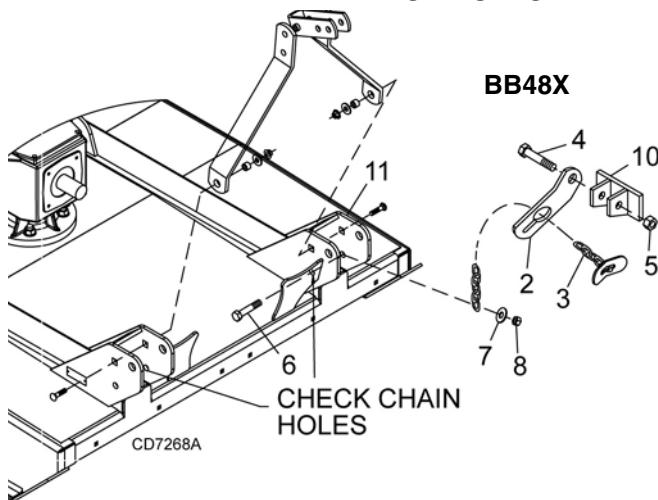

REF	PART	QTY	DESCRIPTION
A	10521	1	Check chain complete
2	7906	2	Check chain bracket, lower
3	18048	2	3/8 Chain, 32-Link and check lug
4	2377	*	3/4 NC x 6 Hex head cap screw GR5
5	2371	*	3/4 NC Hex lock nut
6	12274	*	5/8 NC x 2-1/4 Hex head cap screw GR5

REF	PART	QTY	DESCRIPTION
7	3632	*	5/8 Standard flat washer
8	6239	*	5/8 NC Hex nut
9	-----		Mast plate BB60X, BB72X, BB84X
10	-----		Tractor top link bracket
11	-----		Mast plate BB48X
			* Standard hardware, obtain locally

GEARBOX ASSEMBLY (CAST/CROWN TOP)

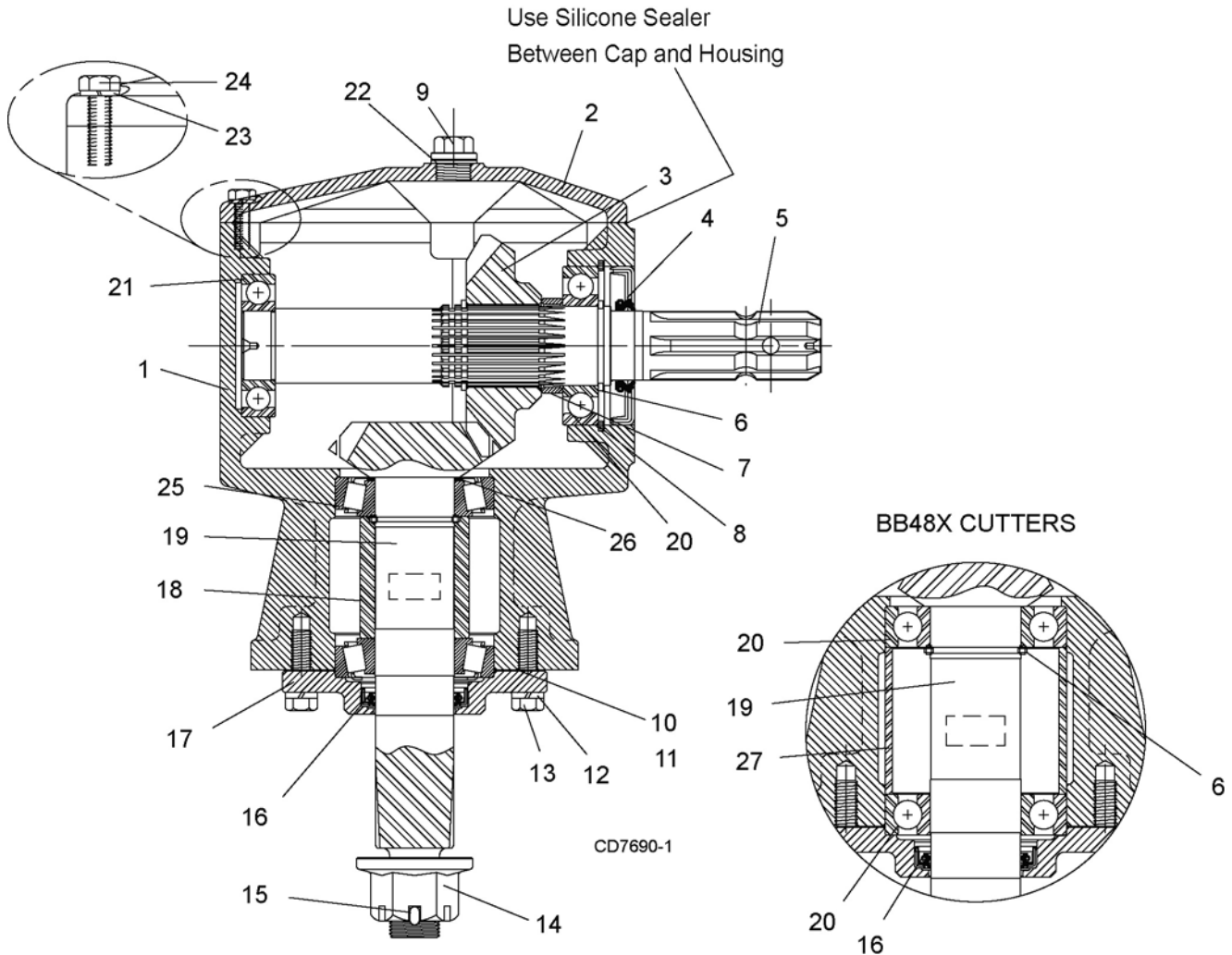

BB60X AND BB72X CUTTERS

REF	PART	QTY	DESCRIPTION	REF	PART	QTY	DESCRIPTION
A	1032587	1	Gearbox repair assembly (BB48X (ball bearing) S/N 1159929 and Above)	10	1018329	A/R	Output gasket (0.30)
A	1032588	1	Gearbox repair assembly (BB60X (tapered bearing) S/N 1159929 and Above)	11	1018330	A/R	Output gasket (0.13)
A	1032585	1	Gearbox repair assembly (BB72X (tapered bearing) S/N 1159929 and Above)	12	----	4	Lock washer
1	----	1	Housing	13	----	4	M10 x 1.5 x 25 Cap screw
2	1019632	1	Inspection cover	14	1018331	1	1" - 14 Slotted flange nut
3	----	1	22 Tooth gear	15	----	1	Cotter pin
4	1018327	1	Input seal	16	1018328	1	Output seal
5	----	1	Input shaft	17	----	1	Output cap
6	----	1	Retaining ring	18	----	1	Output bearing spacer
7	----	1	Gear spacer	19	----	1	Output shaft and pinion
8	----	1	Retaining ring	20	1018326	3	Ball bearing
9	1011780	1	Vent plug and washer	21	1018325	1	Ball bearing
				22	----	2	Sealing washer w/plug
				23	----	6	Lock washer
				24	----	6	M8 x 1.5 x 25 Cap screw
				25	57478	2	Bearing cup and cone
				26	1032963	1	Shim Kit
				27	----	1	Output Bearing Spacer

48 Parts

(Rev. 5/11/2010)
MAN0632 (5/15/2007)

BB48X COMER STANDARD DRIVELINE ASSEMBLY

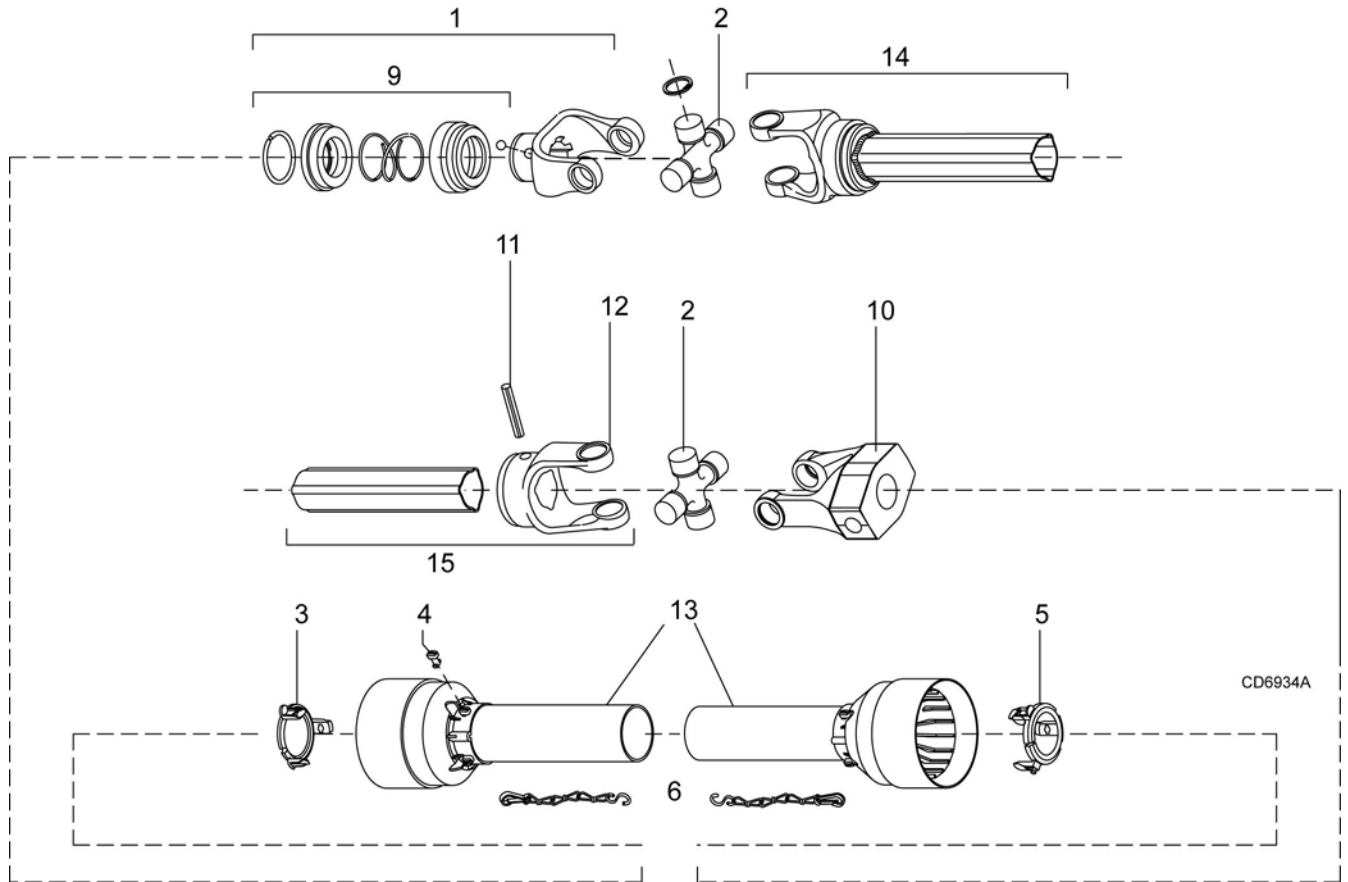

REF	PART	QTY	DESCRIPTION
A	1009509	1	Complete 540 driveline asy
1	1001300	2	Complete collar yoke C12 1-3/8 - 6
2	38478	2	Cross & bearing kit
3	1019442	1	Outer cone fix ring
4	30922	6	Protection fixing screw
5	1019444	1	Inner cone fix ring
6	30917	2	Chain shield tether
9	1001340	1	Lock collar repair kit
10	1019445	1	Special drive yoke
11	1001305	1	Flexible pin
12	1001306	1	Inner tube yoke
13	1021324	1	Shield, complete
14	30926	1	Outer yoke & tube (must be cut to length)
15	30932	1	Inner yoke & tube (must be cut to length)

BB60X COMER STANDARD DRIVELINE ASSEMBLY

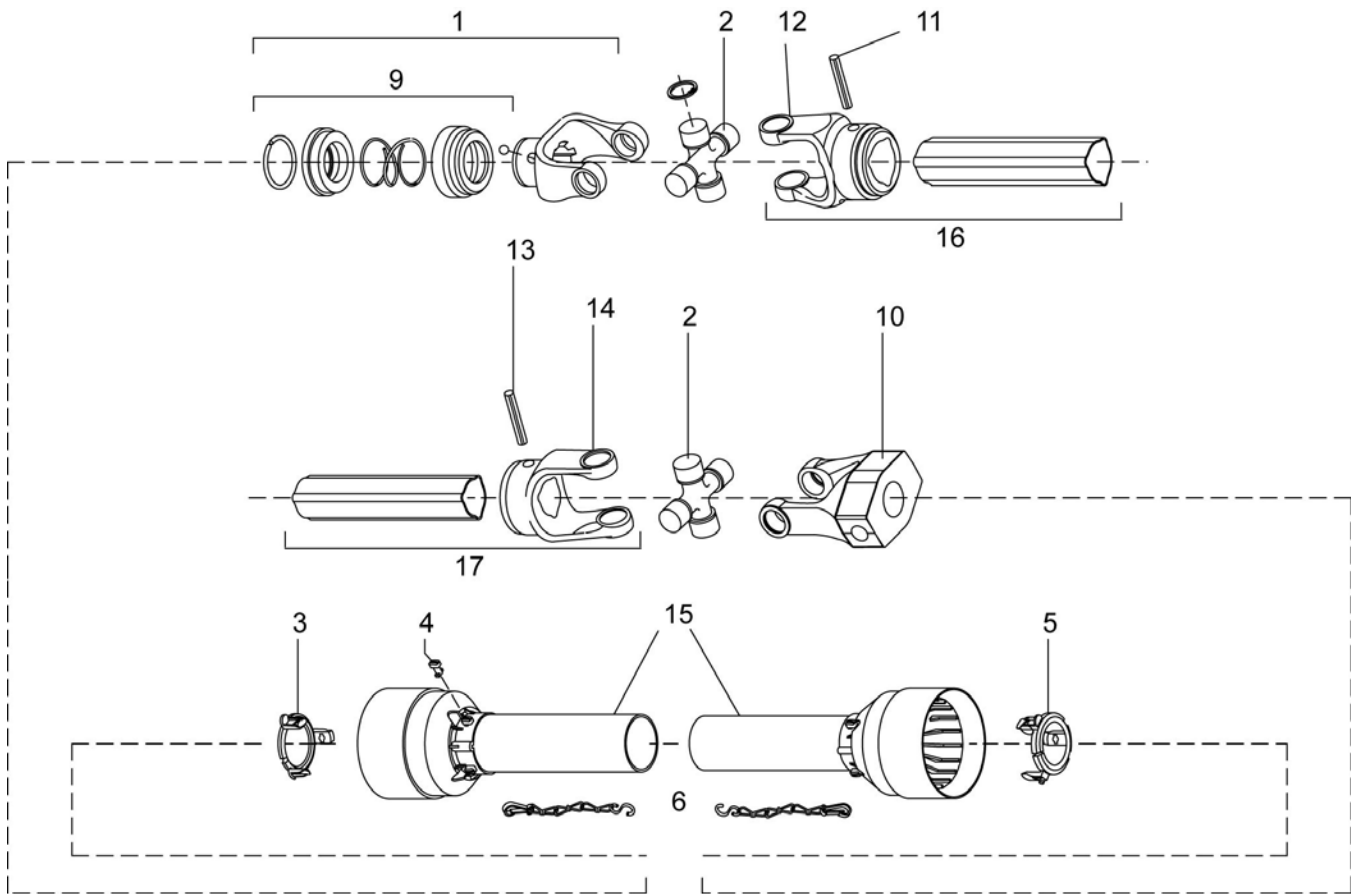

CD6935A

REF	PART	QTY	DESCRIPTION
A	1009510	1	Complete 540 driveline
1	1001300	2	Complete collar yoke C12 1-3/8 - 6
2	38478	2	Cross & bearing kit
3	1019442	1	Outer cone fix ring
4	30922	6	Protection fixing screw
5	1019444	1	Inner cone fix ring
6	30917	2	Chain shielding tether
9	1001340	1	Lock collar repair kit
10	1019445	1	Special drive yoke
11	1001302	1	Flexible pin
12	1001301	1	Outer yoke tube
13	1001305	1	Flexible pin
14	1001306	1	Inner tube yoke
15	1021550	1	Shield, complete
16	30926	1	Outer yoke & tube (must be cut to length)
17	30932	1	Inner yoke & tube (must be cut to length)

50 Parts

(Rev. 9/14/2007)
MAN0632 (5/15/2007)

BB48X & BB60X COMER SLIP CLUTCH DRIVELINE ASSEMBLY (OPTIONAL)

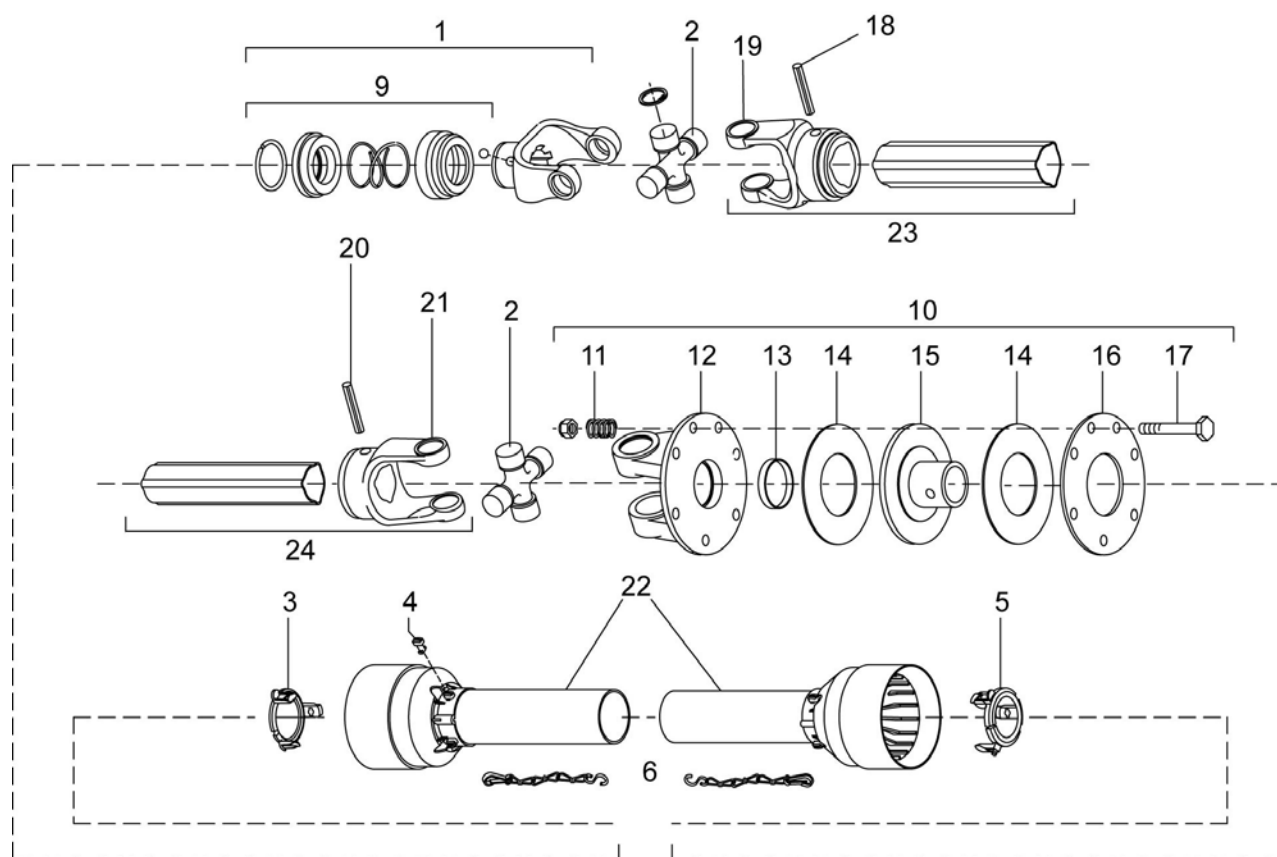

CD6936A

REF	PART	QTY	DESCRIPTION
A	1020900	1	Complete 540 driveline assembly
1	1001300	2	Complete collar yoke C12 1-3/8 - 6
2	38478	2	Cross & bearing kit
3	1019442	1	Outer cone fix ring
4	30922	6	Protection fixing ring
5	1019444	1	Inner cone fix ring
6	30917	2	Chain shield tether
9	1001340	1	Lock collar repair kit
10	1019446	1	Special friction clutch
11	1001311	8	Spring
12	1019447	1	Flanged yoke
13	1001313	1	Bushing
14	1001314	2	Lining ring
15	1019448	1	Special hub F10
16	1001317	1	Pressure plate
17	1001318	8	Bolt & nut M10 x 80
18	1001302	1	Flexible pin
19	1001301	1	Outer yoke tube
20	1001305	1	Flexible pin
21	1001306	1	Inner tube yoke
22	1021551	1	Shield, complete
23	30926	1	Outer yoke & tube (must be cut to length)
24	30932	1	Inner yoke & tube (must be cut to length)

BB72X COMER SLIP CLUTCH DRIVELINE ASSEMBLY

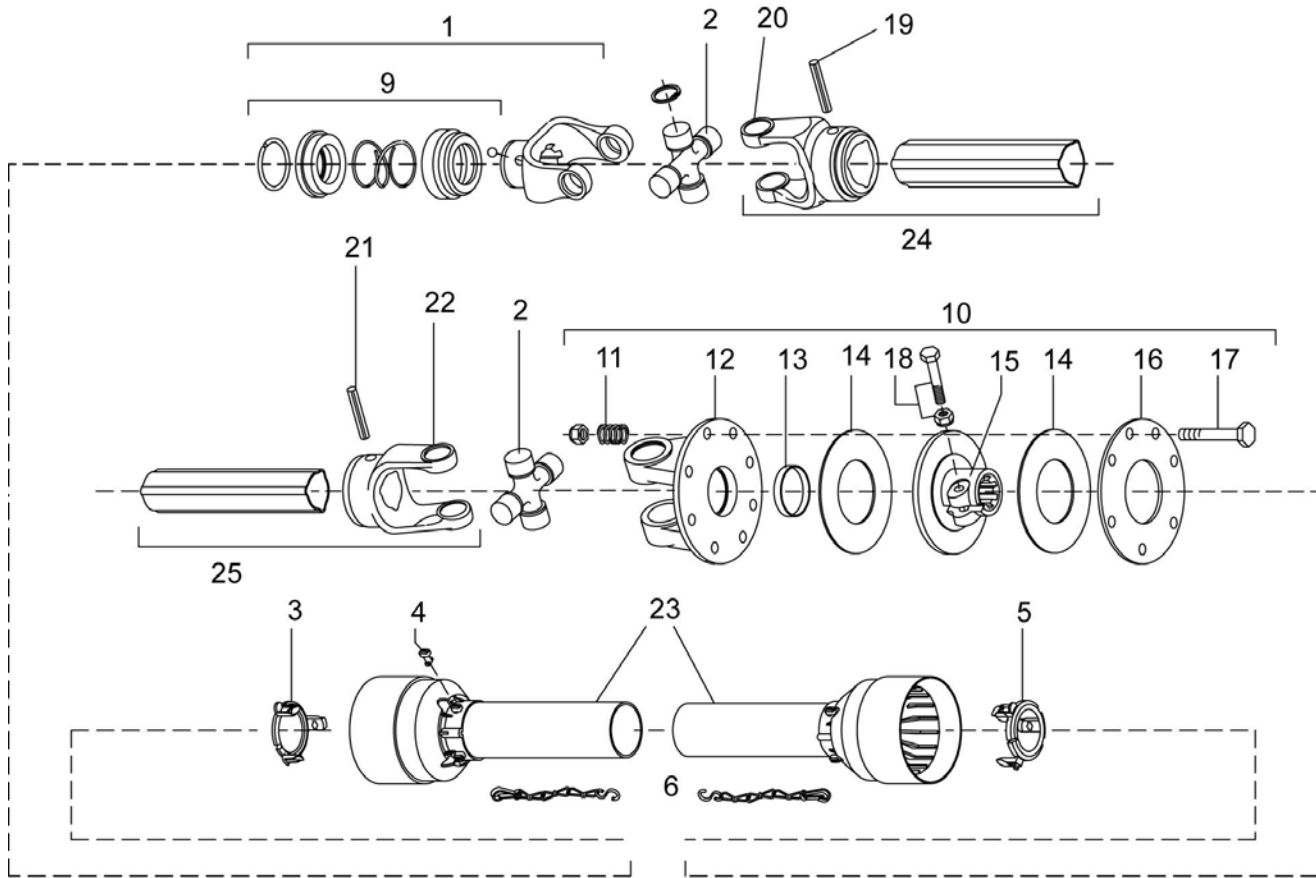

CD6937A

REF	PART	QTY	DESCRIPTION	REF	PART	QTY	DESCRIPTION
A	1020901	1	Complete 540 driveline asy	15	1001316	1	Flanged hub F12
1	1001300	2	Complete collar yoke C12 1-3/8 - 6	16	1001317	1	Pressure plate
2	38478	2	Cross and bearing kit	17	1001318	8	Bolt & nut M10 x 80
3	1019442	1	Outer cone fix ring	18	1001315	1	Bolt & nut M12 x 1.25 x 65
4	30922	6	Protection fixing screw	19	1001302	1	Flexible pin
5	1019444	1	Inner cone fix ring	20	1001301	1	Outer yoke tube
6	30917	2	Chain-shield tether	21	1001305	1	Flexible pin
9	1001340	1	Lock collar repair kit	22	1001306	1	Inner tube yoke
10	1019449	1	Friction clutch	23	1021552	1	Shield, complete
11	1001311	8	Spring	24	30926	1	Outer yoke & tube (must be cut to length)
12	1001312	1	Flanged yoke	25	30932	1	Inner yoke & tube (must be cut to length)
13	1001313	1	Bushing	18	1001315	1	Bolt & nut M12 x 1.25 x 65
14	1001314	2	Lining ring	19	1001302	1	Flexible pin

52 Parts

(Rev. 8/8/2008)
MAN0632 (5/15/2007)

BB84X COMER SLIP CLUTCH DRIVELINE ASSEMBLY

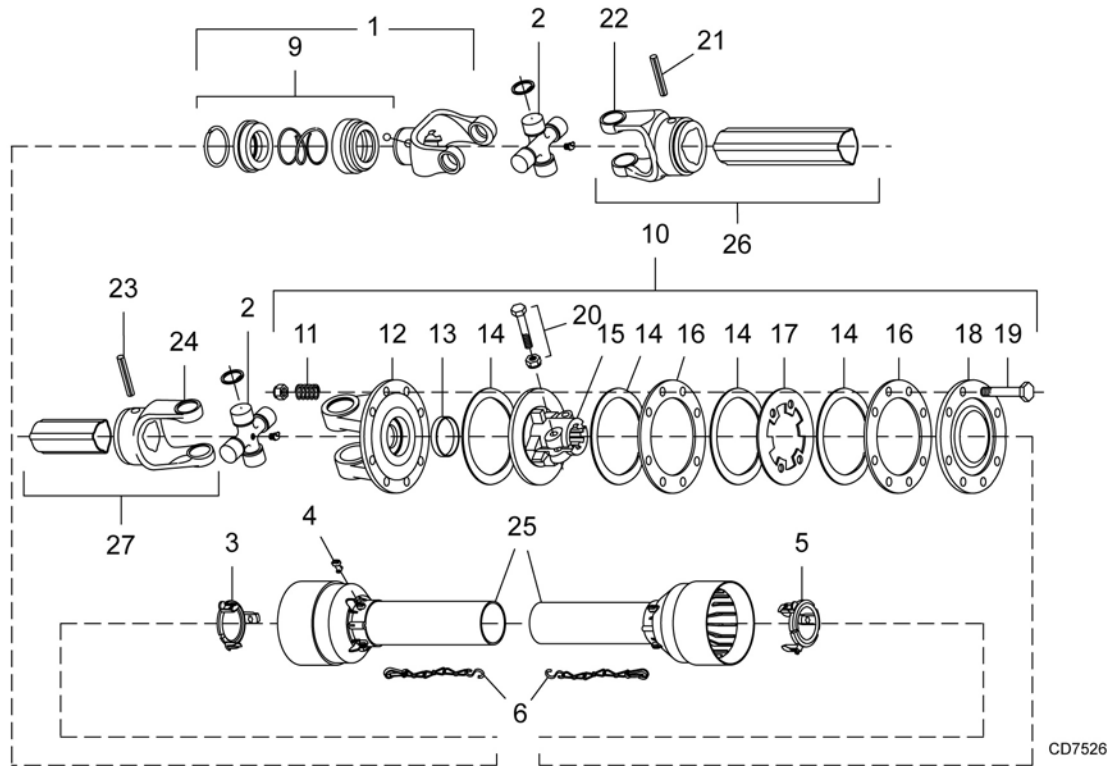

50 Series Drive Dimensions

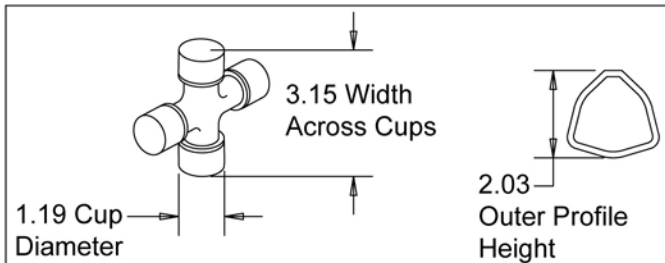

60 Series Drive Dimensions

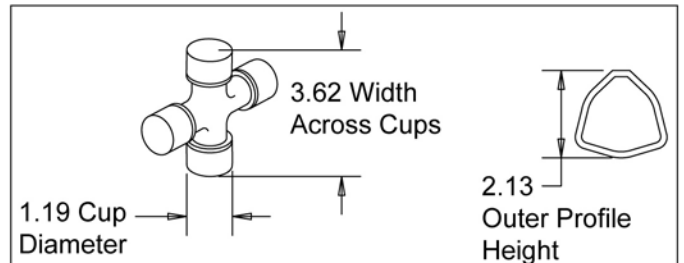

REF	PART 60 Series	PART 50 Series	QTY	DESCRIPTION
A	1024144	1024144	1	Complete driveline asy
1	1001325	1028775	1	Complete collar yoke
2	30962	36990	2	Cross and bearing kit
3	1001333	1028776	1	Outer bearing kit
4	1001309	30922	6	Screw
5	1001334	1028777	1	Inner bearing kit
6	30917	30917	2	Chain, shield tether
9	1001340	1001340	1	Lock collar repair kit
10	1029689	1028778	1	Friction clutch
11	1001311	1001311	8	Spring
12	1029690	1028779	1	Flange yoke
13	1028780	1028780	1	Bushing
14	1028781	1028781	1	Lining ring

REF	PART 60 Series	PART 50 Series	QTY	DESCRIPTION
15	1029691	1028782	1	Flange hub
16	1028783	1028783	2	Inner plate
17	1028784	1028784	1	Intermediate plate
18	1028785	1028785	1	Pressure plate
19	1028786	1028786	8	M10 x 85 mm Bolt & nut
20	1001274	1001315	2	Bolt & nut
21	1001327	1001330	1	Flexible pin
22	1001326	51180	1	Outer tube yoke
23	1001330	1019863	1	Flexible pin
24	1001331	1019860	1	Inner tube yoke
25	1029688	1028787	1	Shield complete
26	1029687	1019862	1	Outer profile
27	1029686	1019861	1	Inner profile

BB84X WALTERSCHEID SLIP CLUTCH DRIVELINE ASSEMBLY

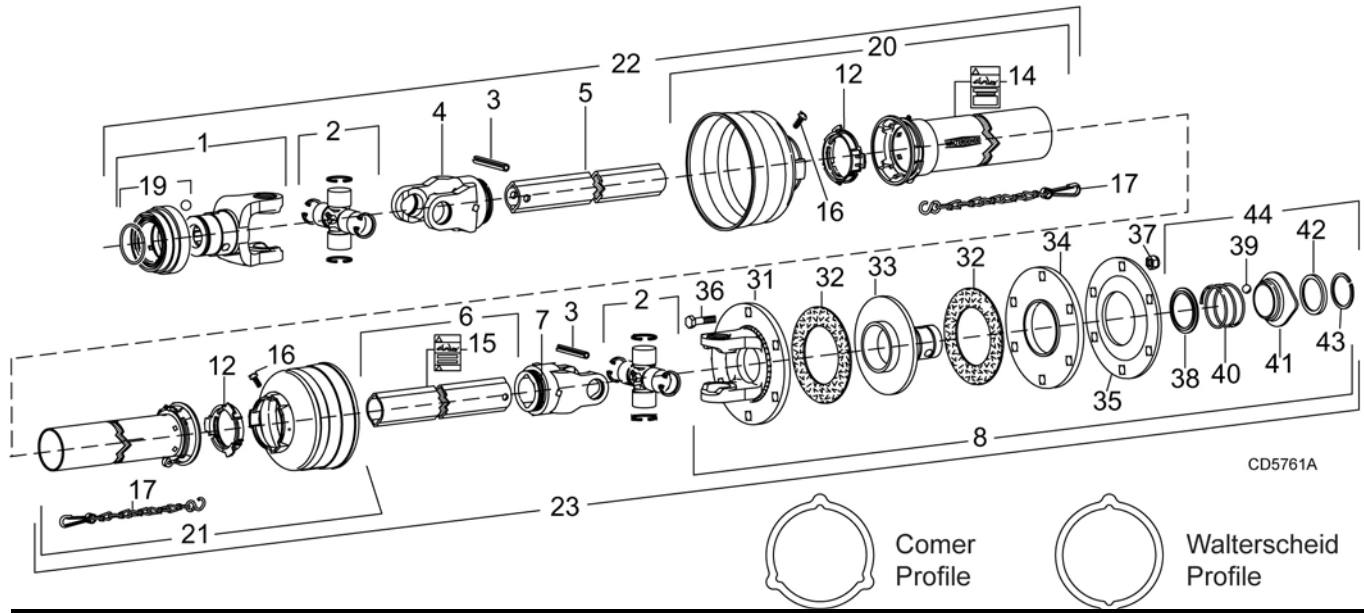

REF	PART	QTY	DESCRIPTION	REF	PART	QTY	DESCRIPTION
1	40574	1	Yoke 1-3/8 - 6 spline	22	57410	1	Shaft assembly, male (complete with guard)
2	110	2	Cross & bearing kit	23	NSS	1	Shaft assembly, female (complete with guard)
3	40764	2	Spring pin 10 x 80	31	57438	1	Flange yoke
4	40575	1	Inboard yoke	32	57432	2	Friction disc (set of 2)
5	40587	1	Inner profile	33	57436	1	Hub, 1-3/8" spline
6	40588	1	Outer profile	34	57434	1	Thrust plate
7	40576	1	Inboard yoke	35	57439	1	Belleville spring plate
8	57412	1	Friction slip clutch	36	57259	6	10 mm x 1.5P x 55 mm Cap screw
12	40766	2	Bearing ring SC25	37	57260	6	10 mm x 1.5P Hex lock nut
14	18864	1	Danger decal, rotating driveline	38	—	1	Back-up ring
15	33347	1	Danger decal, shield missing	39	—	3	Ball
16	40778	2	Screw, included in items 9 & 13	40	—	1	Compression spring
17	40777	2	Anti-rotation chain	41	—	1	Lock collar
19	40589	1	Slide collar kit	42	—	1	Back-up ring
20	40590	1	Outer guard half	43	—	1	Snap ring
21	40591	1	Inner guard half	44	57437	1	QD Flange service kit (items 38-43)

NSS Not Serviced Separately

54 Parts

(Rev. 6/15/2007)
MAN0632 (5/15/2007)

FRONT RUBBER SHIELDING (STANDARD)

REF	PART	QTY	DESCRIPTION
A	1013207	1	Rubber shield kit - BB48X
A	1013208	1	Rubber shield kit 5 ft - BB60X
A	1013209	1	Rubber shield kit 6 ft - BB72X
A	1023042	1	Rubber shield kit 7 ft - BB84X
1	1004128	2	Rubber deflector 25.25 - BB48X
1	1004129	2	Rubber deflector 31.25 - BB60X
1	1004130	2	Rubber deflector 37.25 - BB72X
1	1024119	2	Rubber deflector 43.25 - BB84X
2	1013213	2	Link .25 x 1.00 x 21.50 - BB48X
2	1013214	2	Link .25 x 1.00 x 28.75 - BB60X
2	1013215	2	Link .25 x 1.00 x 34.75 - BB72X
2	1024118	4	Link .25 x 1.00 x 16.00 - BB84X
3	6697 *	8	3/8 NC x 1 Carriage bolt
4	14350 *	8	3/8 NC Flange hex nut

* Standard hardware; obtain locally

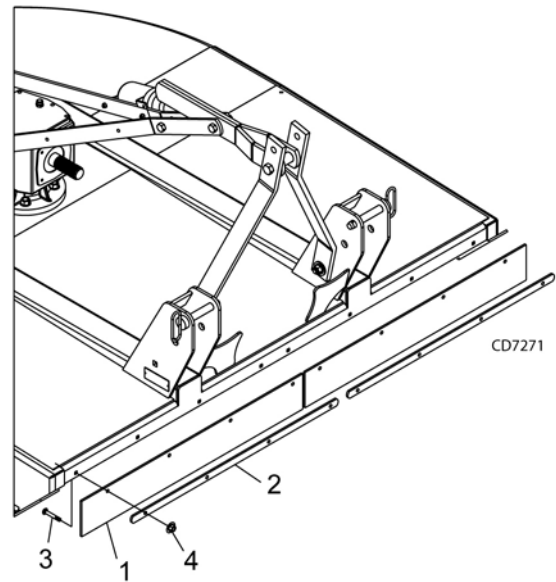

FRONT & REAR CHAIN SHIELDING (OPTIONAL)

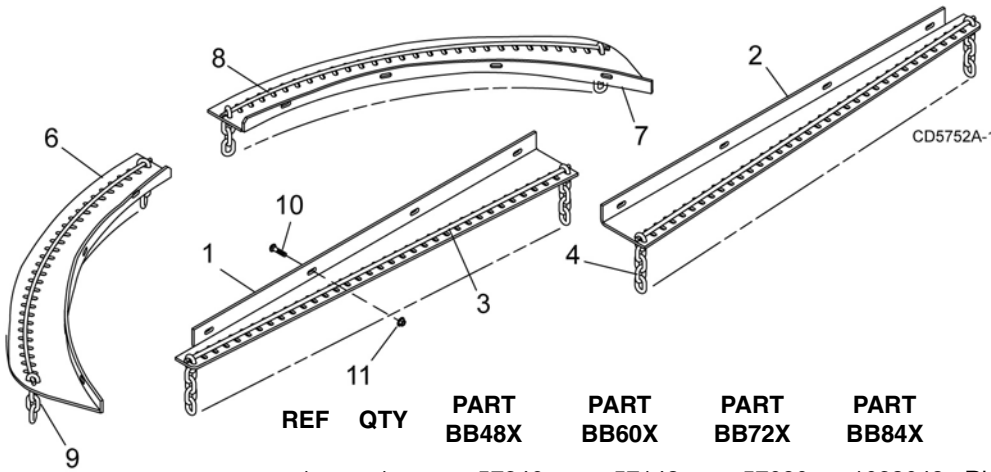

REF	QTY	PART BB48X	PART BB60X	PART BB72X	PART BB84X	DESCRIPTION
1	1	57246	57143	57090	1023048	Right front chain plate
2	1	57254	57144	57091	1023047	Left front chain plate
3	2	1003643	1003645	1007850	1007851	.243 Dia. bent pin (front)
4	AR	5496	5496	5496	5496	5/16 - 7 Link chain (front)
6	1	57248	57142	57088	57125	Right rear chain plate
7	1	57247	57141	57089	57149	Left rear chain plate
8	2	57249	57138	57085	57146	.243 Dia. rolled bent pin (rear)
9	AR	4069	4069	4069	4069	5/16 - 4 Link chain (rear)
10	16	6697 *	6697 *	6697 *	6697 *	3/8 NC x 1 Carriage bolt
11	16	14350	14350	14350	14350	3/8 NC Flange hex nut

AR As Required

* Standard hardware, obtain locally

BOLT TORQUE CHART

Always tighten hardware to these values unless a different torque value or tightening procedure is listed for a specific application.

Fasteners must always be replaced with the same grade as specified in the manual parts list.

Always use the proper tool for tightening hardware: SAE for SAE hardware and Metric for metric hardware.

Make sure fastener threads are clean and you start thread engagement properly.

All torque values are given to specifications used on hardware defined by SAE J1701 MAR 99 & J1701M JUL 96.

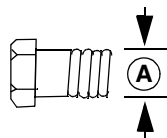

SAE SERIES TORQUE CHART



SAE Grade 2
(No Dashes)

SAE Bolt Head Identification



SAE Grade 5
(3 Radial Dashes)



SAE Grade 8
(6 Radial Dashes)

Ⓐ Diameter (Inches)	Wrench Size	MARKING ON HEAD					
		SAE 2		SAE 5		SAE 8	
		lbs-ft	N-m	lbs-ft	N-m	lbs-ft	N-m
1/4"	7/16"	6	8	10	13	14	18
5/16"	1/2"	12	17	19	26	27	37
3/8"	9/16"	23	31	35	47	49	67
7/16"	5/8"	36	48	55	75	78	106
1/2"	3/4"	55	75	85	115	120	163
9/16"	13/16"	78	106	121	164	171	232
5/8"	15/16"	110	149	170	230	240	325
3/4"	1-1/8"	192	261	297	403	420	569
7/8"	1-5/16"	306	416	474	642	669	907
1"	1-1/2"	467	634	722	979	1020	1383

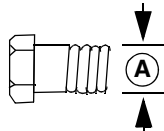

METRIC SERIES TORQUE CHART



Metric
Grade 8.8

Metric Bolt Head Identification



Metric
Grade 10.9

Ⓐ Diameter & Thread Pitch (Millimeters)	Wrench Size	COARSE THREAD				FINE THREAD				Ⓐ Diameter & Thread Pitch (Millimeters)
		MARKING ON HEAD								
		Metric 8.8		Metric 10.9		Metric 8.8		Metric 10.9		
		N-m	lbs-ft	N-m	lbs-ft	N-m	lbs-ft	N-m	lbs-ft	
6 x 1.0	10 mm	8	6	11	8	8	6	11	8	6 x 1.0
8 x 1.25	13 mm	20	15	27	20	21	16	29	22	8 x 1.0
10 x 1.5	16 mm	39	29	54	40	41	30	57	42	10 x 1.25
12 x 1.75	18 mm	68	50	94	70	75	55	103	76	12 x 1.25
14 x 2.0	21 mm	109	80	151	111	118	87	163	120	14 x 1.5
16 x 2.0	24 mm	169	125	234	173	181	133	250	184	16 x 1.5
18 x 2.5	27 mm	234	172	323	239	263	194	363	268	18 x 1.5
20 x 2.5	30 mm	330	244	457	337	367	270	507	374	20 x 1.5
22 x 2.5	34 mm	451	332	623	460	495	365	684	505	22 x 1.5
24 x 3.0	36 mm	571	421	790	583	623	459	861	635	24 x 2.0
30 x 3.0	46 mm	1175	867	1626	1199	1258	928	1740	1283	30 x 2.0

Typical Washer Installations

Bolt

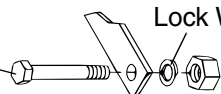

Lock Washer

Flat Washer

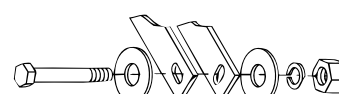
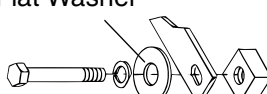

8/9/00

BOLT SIZE CHART

NOTE: Chart shows bolt thread sizes and corresponding head (wrench) sizes for standard SAE and metric bolts.

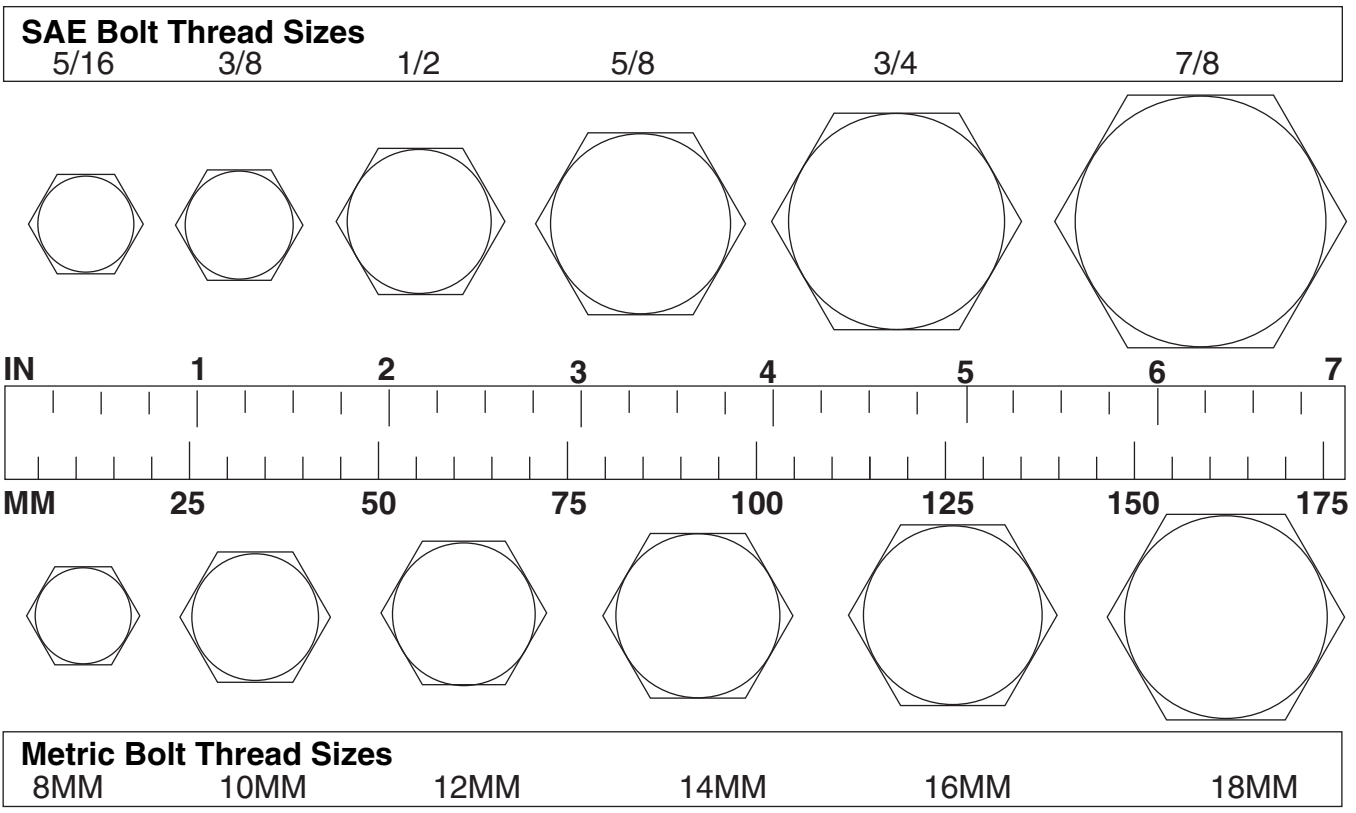

ABBREVIATIONS

AG	Agriculture	MPa.....	Mega Pascal
ASABE.....	American Society of Agricultural & Biological Engineers (formerly ASAE)	N.....	Newton
ASAE	American Society of Agricultural Engineers	NC	National Coarse
ATF	Automatic Transmission Fluid	NF	National Fine
BSPP	British Standard Pipe Parallel	NPSM.....	National Pipe Straight Mechanical
BSPTM	British Standard Pipe Tapered Male	NPT	National Pipe Tapered
CV.....	Constant Velocity	NPT SWF	National Pipe Tapered Swivel Female
CCW	Counter-Clockwise	ORBM	O-Ring Boss - Male
CW.....	Clockwise	P.....	Pitch
F	Female	PBY	Power-Beyond
FT	Full Thread	psi.....	Pounds per Square Inch
GA	Gauge	PTO	Power Take Off
GR (5, etc.)	Grade (5, etc.)	QD.....	Quick Disconnect
HHCS	Hex Head Cap Screw	RH.....	Right Hand
HT.....	Heat-Treated	ROPS	Roll-Over Protective Structure
JIC	Joint Industry Council 37° Degree Flare	RPM	Revolutions Per Minute
LH.....	Left Hand	RT	Right
LT.....	Left	SAE	Society of Automotive Engineers
m.....	Meter	UNC	Unified Coarse
mm.....	Millimeter	UNF	Unified Fine
M.....	Male	UNS.....	Unified Special

INDEX

A

ASSEMBLY

Dealer Set-Up Instructions 36

D

DEALER CHECK LISTS

Delivery (Dealer's Responsibility) 34
Pre-Delivery (Dealer's Responsibility) 34

DEALER SERVICE

Crossbar
Installation 32
Removal 31
Gearbox Maintenance 24
Horizontal Leak Repair 25, 28
Seal Installation 24
Seal Replacement 24
Vertical Shaft Repair 25, 28
Gearbox Repair
Disassemble Gearbox 25, 29
Reassemble Gearbox 26, 29, 30
Reinstall Gearbox 26
Remove Gearbox 25, 29
Universal Joint
Assembly 33
Disassembly 32
Repair 32

G

GENERAL

Abbreviations 57
Bolt Size Chart 57
Bolt Torque Chart 56
General Information 4
Introduction 2
Obtaining Replacement Manuals 2
Product Registration 2
Specifications 4
Table of Contents 3
Warranty
Product 59
Replacement Parts 60

O

OPERATION

Adjustments
Attitude 16
Check Chains 17
Cutting Height 16
Shredding 16
Attaching Cutter to Tractor

BB48X

Attachment 12
Quick Hitch 13
Top Link Adjustment 13

BB60X, BB72X, BB84X

Quick Hitch 14
Standard Hitch 14

Driveline

Attachment 15
Interference Check 16
PTO Installation & Removal 14
Shortening 15

Mowing Speed 12

Operating Technique 17

Pre-Operation Check List (Owner's Responsibility)
17

Storage 17

Tractor Stability 12

OWNER SERVICE

Blade

Installation 19
Removal 19
Servicing 19
Sharpening 20

Blocking Method 18

Cleaning

After Each Use 22
Periodically or Before Extended Storage 22

Driveline Shear Bolt Replacement 22

Lubrication Information 18

Driveline 18

Gearbox 18

Lubrication Chart 19

Shielding Repair 22

Slip Clutch Adjustment 20

Troubleshooting 23

P

PARTS

Index to Parts Lists 43

S

SAFETY

Check Lists

Delivery (Dealer's Responsibility) 34
Pre-Delivery (Dealer's Responsibility) 34
Pre-Operation (Owner's Responsibility) 17

Free Mower Safety Video Order Form 5, 6

Safety & Instructional Decals 10, 11

Safety Rules 7, 8, 9

Safety Symbols Explained 2



WARRANTY

All Models Except Mow'n Machine™ Zero-Turn Mowers

Please Enter Information Below and Save for Future Reference.

Date Purchased: _____ From (Dealer): _____

Model Number: _____ Serial Number: _____

Woods Equipment Company ("WOODS") warrants this product to be free from defect in material and workmanship. Except as otherwise set forth below, the duration of this Warranty shall be for TWELVE (12) MONTHS COMMENCING ON THE DATE OF DELIVERY OF THE PRODUCT TO THE ORIGINAL PURCHASER.

All current model loaders and backhoes are warranted for two (2) years from the date of delivery to the original purchaser.

The warranty periods for specific parts or conditions are listed below:

Part or Condition Warranted	Model Number	Duration (from date of delivery to the original purchaser)
Gearbox Seals	All units listed below	2 years
Gearbox components	BW1260, BW1620, BW1800, BW2400	8 years
	BW240HD, BW180HD, BW180HB, BW126HB	7 years
	BB48X, BB60X, BB72X, BB84X, BB600X, BB720X, BB840X, BB6000X, BB7200X, BB8400X, DS1260, DSO1260, DS1440, TS1680, BW126-3, BW180-3, BW240	6 years
	PHD25, PHD35, PHD65, PHD95, 2162, 3240, DS96, DS120, RCC42, RM550-2, RM660-2, RD990X, PRD6000, PRD7200, PRD8400, S15CD, S20CD, S22CD, S25CD, S27CD, BW180LH, TC/R74, TC/R68, TC/R60, TBW144, TBW180, TBW204	5 years
	RDC54, RD60, RD72, TBW150C, TS/R60, TS/R52, TS/R44	3 years (1 year if used in rental or commercial applications)
Blade spindles	RM550-2, RM660-2, RD990X, PRD6000, PRD7200, PRD8400, TBW144, TBW180, TBW204	3 years
Rust-through	BB600, BB720, BB840, BB6000, BB7200, BB8400, BW126-3, BW126HB, BW180-3, BW180HB, BW180HD, BW1260, BW1800, BW240, BW240HD, 2162, 3240, DS1260, DSO1260, DS1440, TS1680	10 years

Under no circumstances will this Warranty apply in the event that the product, in the good faith opinion of WOODS, has been subjected to improper operation, improper maintenance, misuse, or an accident. This Warranty does not apply in the event that the product has been materially modified or repaired by someone other than WOODS, a WOODS authorized dealer or distributor, and/or a WOODS authorized service center. This Warranty does not cover normal wear or tear, or normal maintenance items. This Warranty also does not cover repairs made with parts other than those obtainable through WOODS.

This Warranty is extended solely to the original purchaser of the product. Should the original purchaser sell or otherwise transfer this product to a third party, this Warranty does not transfer to the third party purchaser in any way. There are no third party beneficiaries of this Warranty.

WOODS makes no warranty, express or implied, with respect to engines, batteries, tires or other parts or accessories not manufactured by WOODS. Warranties for these items, if any, are provided separately by their respective manufacturers.

WOODS' obligation under this Warranty is limited to, at WOODS' option, the repair or replacement, free of charge, of the product if WOODS, in its sole discretion, deems it to be defective or in noncompliance with this Warranty. **The product must be returned to WOODS with proof of purchase within thirty (30) days after such defect or noncompliance is discovered or should have been discovered, routed through the dealer and distributor from whom the purchase was made, transportation charges prepaid.** WOODS shall complete such repair or replacement within a reasonable time after WOODS receives the product. **THERE ARE NO OTHER REMEDIES UNDER THIS WARRANTY. THE REMEDY OF REPAIR OR REPLACEMENT IS THE SOLE AND EXCLUSIVE REMEDY UNDER THIS WARRANTY.**

THERE ARE NO WARRANTIES WHICH EXTEND BEYOND THE DESCRIPTION ON THE FACE OF THIS WARRANTY. WOODS MAKES NO OTHER WARRANTY, EXPRESS OR IMPLIED, AND WOODS SPECIFICALLY DISCLAIMS ANY IMPLIED WARRANTY OF MERCHANTABILITY AND/OR ANY IMPLIED WARRANTY OF FITNESS FOR A PARTICULAR PURPOSE.

WOODS shall not be liable for any incidental or consequential losses, damages or expenses, arising directly or indirectly from the product, whether such claim is based upon breach of contract, breach of warranty, negligence, strict liability in tort or any other legal theory. Without limiting the generality of the foregoing, Woods specifically disclaims any damages relating to (i) lost profits, business, revenues or goodwill; (ii) loss of crops; (iii) loss because of delay in harvesting; (iv) any expense or loss incurred for labor, supplies, substitute machinery or rental; or (v) any other type of damage to property or economic loss.

This Warranty is subject to any existing conditions of supply which may directly affect WOODS' ability to obtain materials or manufacture replacement parts.

No agent, representative, dealer, distributor, serviceperson, salesperson, or employee of any company, including without limitation, WOODS, its authorized dealers, distributors, and service centers, is authorized to alter, modify, or enlarge this Warranty. Answers to any questions regarding warranty service and locations may be obtained by contacting:

Woods Equipment Company

2606 South Illinois Route 2
Post Office Box 1000
Oregon, Illinois 61061 USA

800-319-6637 tel
800-399-6637 fax
www.WoodsEquipment.com



ALITEC™

BMP®

CENTRAL FABRICATORS®

GANNON®

GILL®

WAIN-ROY®

WOODS®



WARRANTY

(Replacement Parts For All Models Except Mow'n Machine™
Zero-Turn Mowers and Woods Boundary™ Utility Vehicles)

Woods Equipment Company ("WOODS") warrants this product to be free from defect in material and workmanship for a period of ninety (90) days from the date of delivery of the product to the original purchaser with the exception of V-belts, which will be free of defect in material and workmanship for a period of 12 months.

Under no circumstances will this Warranty apply in the event that the product, in the good faith opinion of WOODS, has been subjected to improper operation, improper maintenance, misuse, or an accident. This Warranty does not cover normal wear or tear, or normal maintenance items.

This Warranty is extended solely to the original purchaser of the product. Should the original purchaser sell or otherwise transfer this product to a third party, this Warranty does not transfer to the third party purchaser in any way. There are no third party beneficiaries of this Warranty.

WOODS' obligation under this Warranty is limited to, at WOODS' option, the repair or replacement, free of charge, of the product if WOODS, in its sole discretion, deems it to be defective or in noncompliance with this Warranty. **The product must be returned to WOODS with proof of purchase within thirty (30) days after such defect or noncompliance is discovered or should have been discovered, routed through the dealer and distributor from whom the purchase was made, transportation charges prepaid.** WOODS shall complete such repair or replacement within a reasonable time after WOODS receives the product. THERE ARE NO OTHER REMEDIES UNDER THIS WARRANTY. THE REMEDY OF REPAIR OR REPLACEMENT IS THE SOLE AND EXCLUSIVE REMEDY UNDER THIS WARRANTY.

THERE ARE NO WARRANTIES WHICH EXTEND BEYOND THE DESCRIPTION ON THE FACE OF THIS WARRANTY. WOODS MAKES NO OTHER WARRANTY, EXPRESS OR IMPLIED, AND WOODS SPECIFICALLY DISCLAIMS ANY IMPLIED WARRANTY OF MERCHANTABILITY AND/OR ANY IMPLIED WARRANTY OF FITNESS FOR A PARTICULAR PURPOSE.

WOODS shall not be liable for any incidental or consequential losses, damages or expenses, arising directly or indirectly from the product, whether such claim is based upon breach of contract, breach of warranty, negligence, strict liability in tort or any other legal theory. Without limiting the generality of the foregoing, Woods specifically disclaims any damages relating to (i) lost profits, business, revenues or goodwill; (ii) loss of crops; (iii) loss because of delay in harvesting; (iv) any expense or loss incurred for labor, supplies, substitute machinery or rental; or (v) any other type of damage to property or economic loss.

This Warranty is subject to any existing conditions of supply which may directly affect WOODS' ability to obtain materials or manufacture replacement parts.

No agent, representative, dealer, distributor, service person, salesperson, or employee of any company, including without limitation, WOODS, its authorized dealers, distributors, and service centers, is authorized to alter, modify, or enlarge this Warranty.

Answers to any questions regarding warranty service and locations may be obtained by contacting:

ALITEC™
BMP®
CENTRAL FABRICATORS®
GANNON®
GILL®
WAIN-ROY®
WOODS®

WOODS®

**Woods Equipment
Company**

2606 South Illinois Route 2
Post Office Box 1000
Oregon IL 61061

800-319-6637 tel
800-399-6637 fax
www.WoodsEquipment.com