



clarion
POWER SYSTEM

DPX 1001.2
2/1 CHANNEL POWER AMPLIFIER

**OPERATION
INSTALLATION
MANUAL**

Clarion DPX1001.2 Power System Amplifier

TABLE OF CONTENTS

Introduction	2
Description	3
Input Connections and Audio Controls	4
Connections for Power and Speakers	5
Applications	6
Installation	9
Mounting Precautions	9
Wiring Precautions	9
Setting the Gain	12
Setting the Crossover	12
Setting the Bass Boost	12
Final System Checks	13
Troubleshooting	13
Product Specs	14
Warranty Information	15

INTRODUCTION

The Clarion DPX1001.2 is a full-featured two-channel amplifier that incorporates the following features:

- Digital Technology for high efficiency and high power output.
- Full frequency response with low distortion and exceptional signal to noise performance.
- Advanced circuitry design that features bridgeable and mixed mode operation for use in various audio systems, including those with satellite speakers and/or subwoofers.
- Variable low-pass electronic crossover with a 12dB or 24db per octave slope and full adjustable range (from 55Hz to 550Hz) to aid in audio system configuration.
- Variable bass boost circuit to reinforce low frequency signals that may be lost due to subwoofer box design.
- Adjustable input level controls with ground loop isolation, allowing a wide range of input signals.
- Remote turn-on with “soft start” muting to prevent turn on “thump”.
- Pulse-width modulated (PWM) MOSFET power supply with low AM RFI and protection circuits for overheating and speaker shorts.
- 1-ohm load capability to drive a variety of speaker systems (stereo mode)

- Gold-plated input/output connectors
- Aluminum heat sink for efficient heat dissipation
- Low profile, compact size for space limited installations
- Wired remote Sub Level Control (BC2) included
- Full range or low pass output mode
- High level inputs
- Built-in Subsonic filter

ABOUT THE MANUAL AND WARRANTY

To start enjoying your new Clarion two-channel amplifier, please read the instructions stated in this manual. Keep all instructions for future reference. Also, **save your original sales receipt as proof of purchase.**

DESCRIPTION

- The Clarion DPX1001.2 two-channel amplifier provides 150 watts x2 into a 4 ohm load, 300 watts x2 of power into a 2 ohm load. and 500 watts x2 into a 1 ohm load. This full featured model is an excellent choice for a variety of car audio sound system configurations.
- The DPX1001.2 uses an unregulated MOSFET power supply for superior control of output wattage. A toroid-coil transformer yields maximum power transfer with minimal heat loss. Extensive attention to circuitry design keeps AM RFI at low levels, so you won't hear unwanted noise when the level is cranked up. Protection circuits safeguard the amplifier when overheating, speaker shorts, or improper load conditions occur.
- All connections and controls of the DPX1001.2 are on the end panels and are easy to understand. Gold-plated RCA and barrier connectors are used to ensure the best electrical connection for your system. Included is a wired remote sub level control (BC2) for adjusting the amplifier gain from the front of the vehicle.
- Multimode operation is a unique feature that allows the DPX1001.2 to maximize power output at different loads. In the regular mode (loads of 4 ohm or 2 ohm stereo), the power output is 150 watts x2 into 4 ohms and 300 watts x 2 into 2 ohms. With a 1 ohm load, the power output will increase to 500 watts x 2. This feature will accommodate various system configurations.

NOTE: Activation of the 1 ohm mode will occur when the output load is 1 ohm. The amplifier will shut down for 15 seconds and then turn back on in the 1 ohm mode. To reset this feature, the power connections must be disconnected for 30 seconds and then reconnected.

Clarion DPX1001.2 Power System Amplifier

INPUT CONNECTIONS AND AUDIO CONTROLS

The front panel of the DPX1001.2 contains connections for RCA Inputs, Speaker Level Inputs and Audio Controls as shown below.

The RCA Input Connections are gold-plated RCA jacks and are labeled as RIGHT and LEFT.

Figure 1-

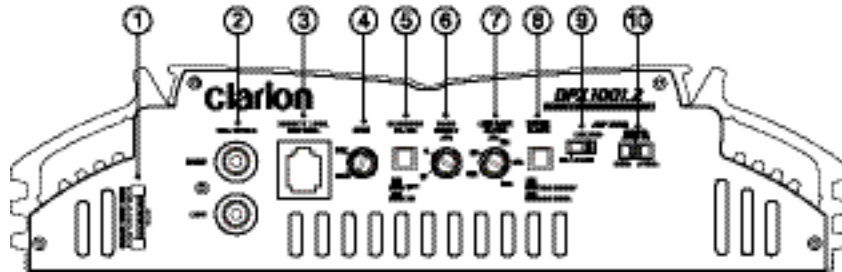

- | | |
|-------------------------------------|--------------------------------|
| 1. Speaker Level Inputs | 6. Bass Boost Control |
| 2. RCA Input Jacks | 7. Freq (Hz) Selection Control |
| 3. Remote Sub level Connector | 8. X-Over Slope Select Switch |
| 4. Gain Control | 9. Output Select Switch |
| 5. Subsonic Filter Selection Switch | 10. Input Select Switch |

• **Remote Sub level Control** - This port is for the supplied remote gain control that allows adjustment from a remote location .

• **Subsonic Filter** - This switch will activate the Subsonic Filter Circuit which eliminates unwanted frequencies from 24Hz and below.

• **Gain Control** - This allows you to set the nominal operating level of the amplifier. The amplifier's range, 250mV to 2.5V for RCA inputs or 500mV to 5V for speaker level inputs, which can accommodate input levels from virtually any brand of source unit.

• **Bass Boost Control**- The amplifier also features a "high-Q" (i.e. narrow frequency band) Bass Boost circuit. It acts much like an equalizer, with adjustable gain (from 0 to +15dB) fixed at 45Hz. Use this feature to tune low-frequency audio response to compensate for a less than ideal subwoofer enclosure design. The added boost produces rich, full bass tones that are normally difficult to reproduce in the car audio environment. NOTE: If Bass Boost is undesired, set Bass Boost to 0dB.

Low-pass Filter Controls

• **Frequency (Hz) Selection Control** - The crossover frequency is fully adjustable between 55Hz and 550Hz for a wide range of crossover points.

Use this feature, along with your speaker manufacturer's recommended crossover frequencies, to quickly design a more advanced system.

- **X-Over Slope Switch** - This switch will change the X-Over between a 12db and 24dB per octave slope. The steep crossover slope keeps midrange tones out of the subwoofer and thereby eliminates an unnatural "nasal" tone quality in the audio system.
- **Output Mode Switch** - This switch is to change the output between low-pass or fullrange. If lowpass is selected, the lowpass filter controls will control the crossover frequency.
- **Input Mode Switch** - This switch allows you to set the input mode. Stereo input allows full left and right stereo operation. Right (bridged) input allows single channel input for bridged operation. This is especially useful in high-powered systems when using one amplifier for each subwoofer/speaker. L + R (sum mono) allows a stereo input to be summed into a mono output.
- **Speaker Level Inputs** - These provide connections for a high-level stereo source. These connections are provided for installations where the source unit's RCA outputs are unavailable.

WARNING: When using the speaker (high-level) inputs, the Black wire must be grounded at the radio. Failure to do this will result in noise and improper operation.

CONNECTIONS FOR POWER AND SPEAKERS

The rear panel of the DPX1001.2 contains power and speaker connections as shown below.

Figure 2-

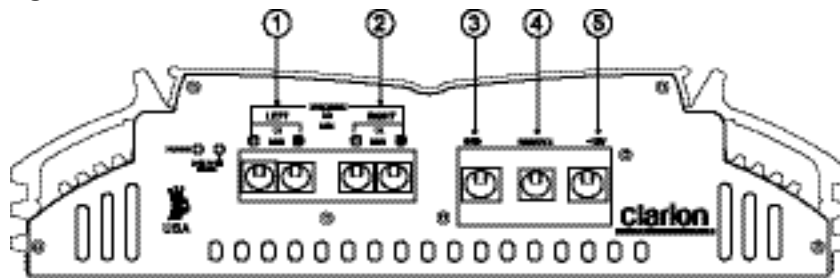

- | | |
|-------------------------|-------------------------|
| 1. Left Speaker Output | 4. Remote Turn-on Input |
| 2. Right Speaker Output | 5. Battery + 12v Input |
| 3. Ground Input | |

Clarion DPX1001.2 Power System Amplifier

APPLICATIONS

The Clarion DPX1001.2 2-channel car audio amplifier can be used in a variety of system applications. Here are some examples to help plan your own installation.

Bridged-Mono Subwoofer System

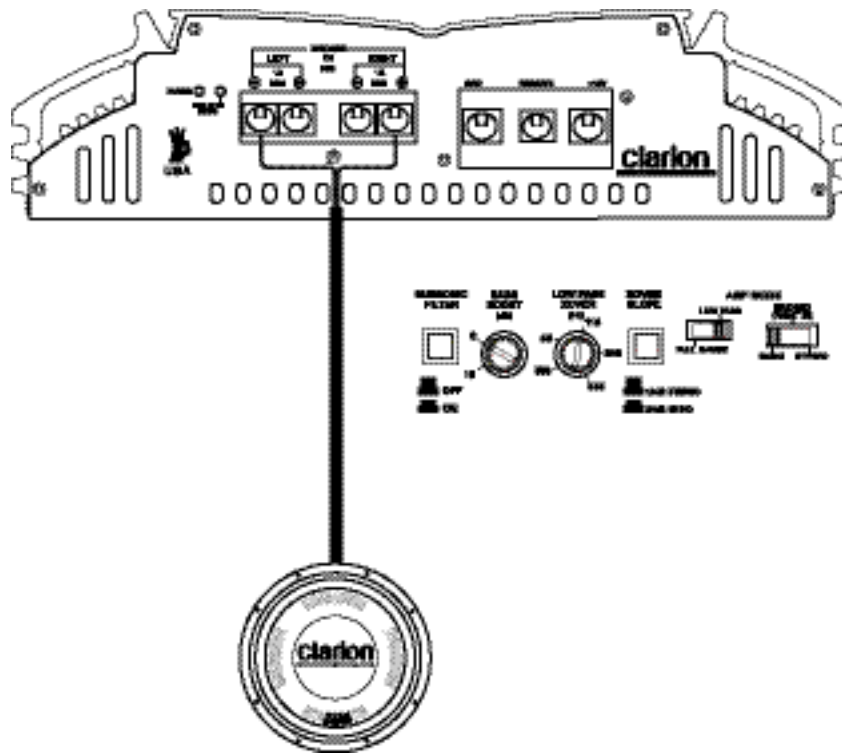

Set X-Over Mode to LP and adjust
FREQ to speaker specifications.

Figure 3 - In this application the amplifier is bridged for mono operation to drive a subwoofer. Minimum load in the bridged mode is 2 ohms.

2-Channel Full Range, Satellite, or Subwoofer Stereo System

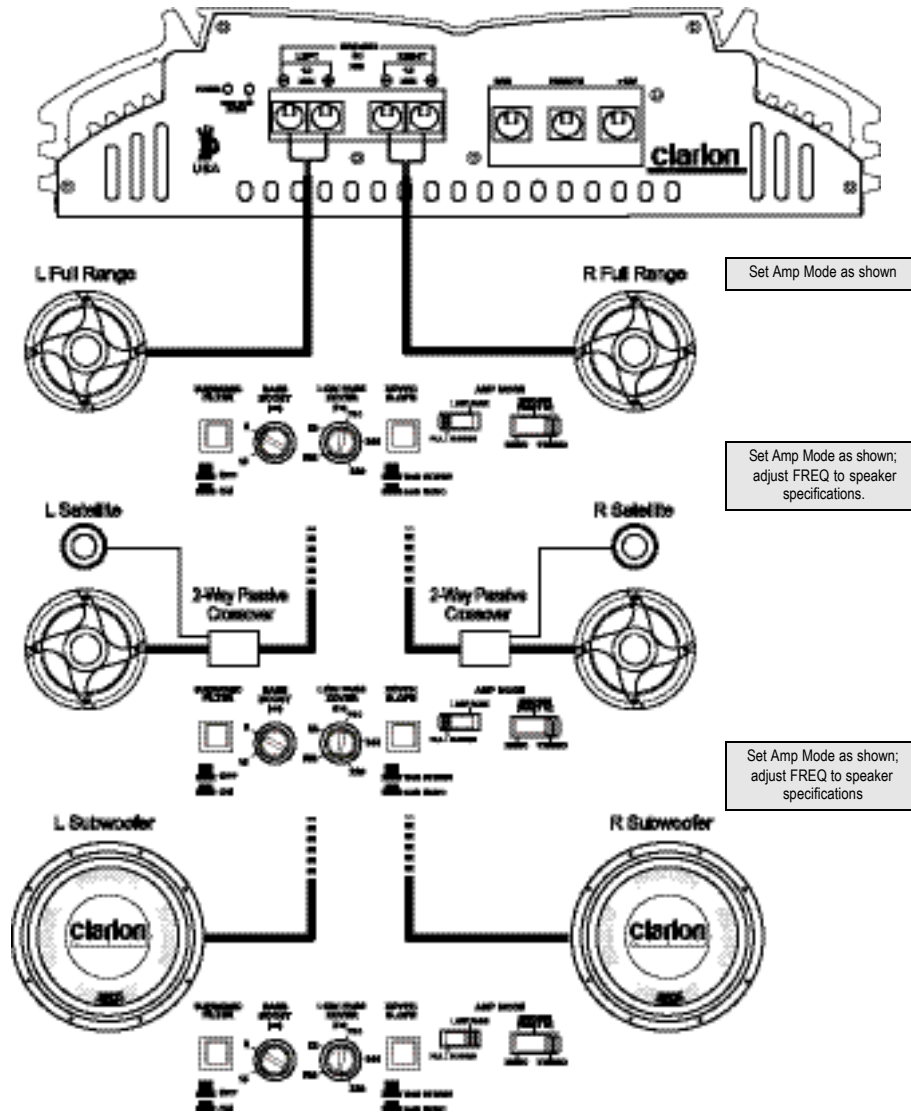
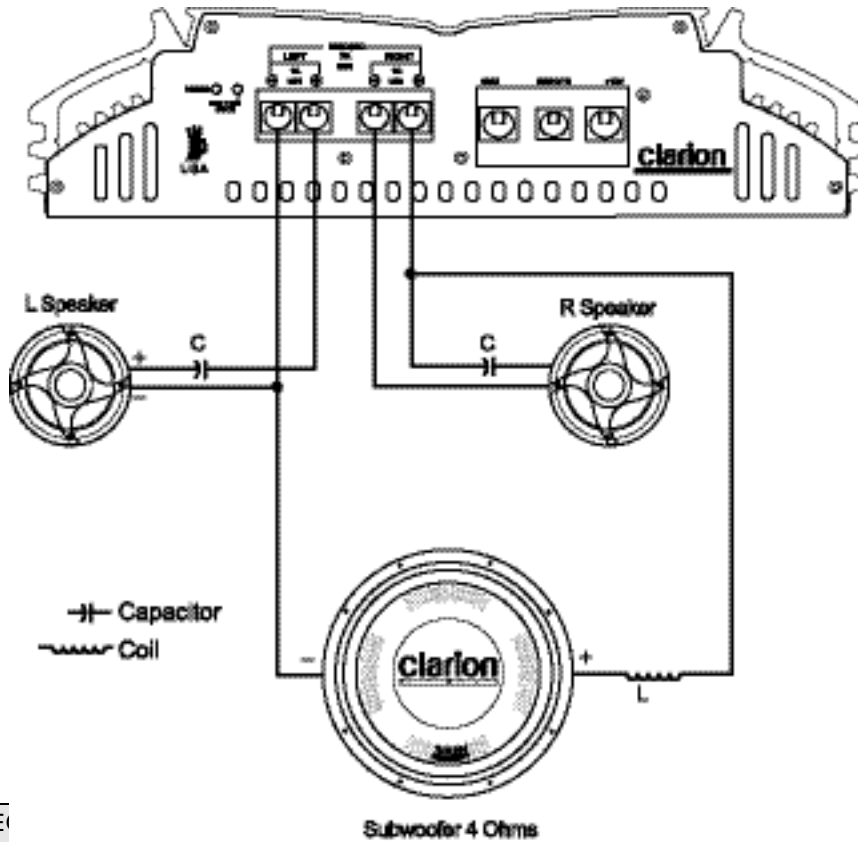

Figure 4 - In this application, the amplifier is used in stereo and drives two full-range (or satellite or subwoofer) speakers. NOTE: A passive crossover must be used with satellite speakers. Minimum load in the stereo mode is 1ohm.

Clarion DPX1001.2 Power System Amplifier

(Set INPUT SELECT Switch to STEREO)
Mixed-Mode Satellite and Subwoofer System



FRE		
8		
1		
1		
1		
200	3.2	199



Set amp mode switch to fullrange

NOTE: Chart values based on 4 ohm speakers.

Figure 5 - The amplifier can be configured for a mixed-mode operation. The table provides component values to create a 6dB per octave crossover at specified frequencies. Use components that have a $\pm 5\%$ tolerance and capacitors rated at 100V. **NOTE:** Choose the same frequency for both LP and HP crossovers. Do not overlap frequencies, as this may damage the amplifier.

INSTALLATION

This section lists Mounting and Wiring Precautions for installing the Clarion DPX1001.2. These safeguards provide enough detail to complete the installation successfully. If you do not have the necessary skills, Clarion recommends consulting your authorized Clarion dealer for installation.

MOUNTING PRECAUTIONS

Although the Clarion DPX1001.2 incorporate heat sinks and protection circuits, mounting the amplifier in a tight space without any air movement can still damage internal circuitry over time. Choose a site that provides adequate ventilation around the amplifier. For easy system set-up, mount the amplifier so the front panel controls can be accessible after installation.

In addition, observe the following precautions:

1. For the most efficient cooling, mount the amplifier so cool air runs along the length of the fins rather than across them. Remember, any moving air will dissipate heat.
2. Mount the amplifier on a rigid surface. Avoid mounting to subwoofer enclosures or areas prone to vibration. Do not install the amplifier on plastic or other combustible materials.
3. Prior to drilling, make sure proposed mounting holes will not cut into the fuel tank, fuel lines, brake lines (under chassis) or electrical wiring.

WIRING PRECAUTIONS

Read all wiring precautions. If you are not sure of the connections, contact your authorized Clarion dealer.

1. Before installation, make sure the source unit Power switch is in the OFF position.
2. Disconnect the negative (-) lead of the battery before making any power connections.
3. When making connections, be sure that each connection is clean and secure. Insulate final connections with electrical tape or shrink tubing. Failure to do so may damage your equipment.
4. A secure clean ground connection is critical to the performance of your Clarion amplifier. Use the shortest ground wire possible and securely connect to the car chassis to minimize resistance and avoid noise problems.

Clarion DPX1001.2 Power System Amplifier

5. Add an external fuse on the amplifier's positive (+) power lead and connect it as close as possible to the vehicle's (+) battery terminal. Use a fuse rated to the total current consumption of the amplifier(s). Adding an external fuse will protect the electrical system from short circuits that can cause a fire.
6. Refer to Figure 6 when making electrical connections. Connect the amplifier's positive (+) lead via a fuse directly to the positive (+) terminal on the battery. Do not connect this wire to the car's fuse panel. Use red-insulated 10-gauge (or larger) wire for the amplifier's positive (+) power lead and the same-gauge black-insulated wire for the ground.
7. When replacing the amplifier's fuse, always use one having the same current rating. Substituting a higher-rated fuse or a slow-blow type can result in serious damage to the amplifier.
8. Never ground the speakers to the vehicle chassis or body.
9. Make sure that your vehicle's electrical system (alternator, battery, etc.) is capable of handling the additional load. If you are planning a multi-amplifier system, you may need to add a second battery and possibly upgrade the alternator with a higher-output rated model. Consult your authorized Clarion dealer for recommendations.
10. To avoid noise problems, run the amplifier's positive (+) power lead along one side of the vehicle to the battery. Run the remote turn-on wire and RCA audio cables down the center, and route the speaker wires along the remaining side. If wires must cross, run them perpendicular to each other.
11. When creating passage holes for the power wire, use grommets to eliminate any sharp edges created during drilling. This will protect the wire from being nicked and causing a short circuit.
12. Excess cable can cause signal loss and act as an "antenna" for noise. Use only high-quality RCA cables that are no longer than necessary to make a direct connection with the source unit or equalizer.

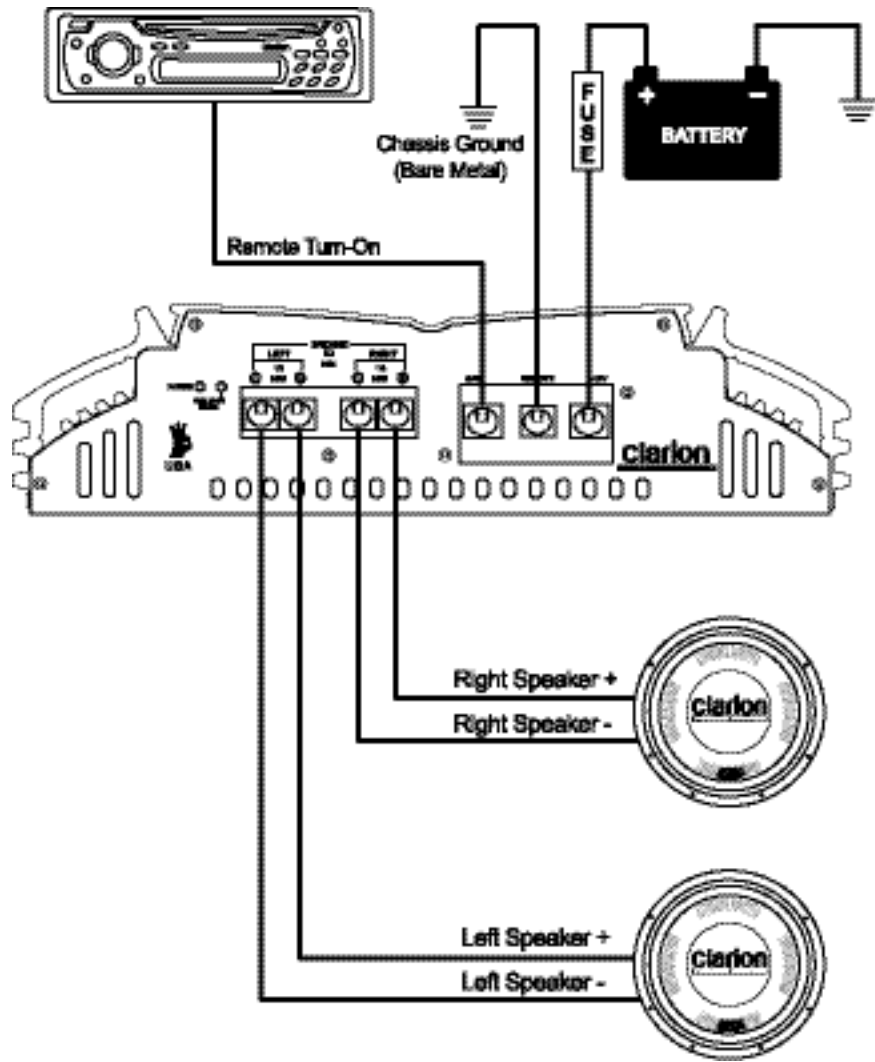

Figure 6. - Electrical connections for the DPX1001.2

Clarion DPX1001.2 Power System Amplifier

SETTING THE GAIN

After completing the installation, follow these steps to set the Gain Control and then perform the Final System Checks.

1. Turn the Gain Control all the way counter-clockwise.
2. Turn the vehicle's Ignition Switch to the ON position. Then turn the ON/OFF Switch on the source units to the ON position. Set all Tone or Equalization Controls to "flat" positions and turn Loudness off.

NOTE: If the system uses an equalizer, set its frequency controls to "flat" positions.

3. Play a CD or Tape and set the Volume Control at 75% of full level.
4. Slowly increase the Gain Control. Stop when you hear a slight distortion of audio.

SETTING THE CROSSOVER

The Clarion DPX1001.2 features a fully adjustable crossover. To set the crossover, follow these steps.

1. Using the Amp Mode Switch, select the desired mode - Low Pass or Full Range.

NOTE: Fullrange selection will disable x-over adjustments.

2. Using the Freq (Hz) Control, select the desired frequency.

SETTING THE BASS BOOST

1. Initially set the Bass Boost control to its full left position (i.e. 0dB).

2. Listen to a variety of music styles (e.g. Rock, Rap, etc.) and slowly increase the Bass Boost control until a noticeable increase in low bass response is perceived.

3. Slowly adjust the Bass Boost control (up or down) to realize the best bass response.

CAUTION: If you hear a "pop" (due to speaker over-excursion), lower the Bass Boost to prevent speaker damage. If the system sounds muddy and distorted (due to amplifier clipping), lower Bass Boost to avoid shutdown from overheating.

FINAL SYSTEM CHECKS

1. Start the engine and turn on the source unit. After a two-second delay, slowly increase the Volume Control and listen to the audio. If you hear any noise, static, distortion or no sound at all, check the connections, and also refer to Troubleshooting. Depending on your system design, the levels may become quite loud even at low Volume Control settings. Until you get an "audio feel" of the system's power, use care when adjusting controls.
2. Turn the Balance Controls to their extreme positions and listen to the results. Audio imaging should match control settings (audio from the left speaker when balance is left).
3. Increase the volume and verify that the amplifier reproduces audio (at full frequencies) without distortion. If you hear distortion, check the connections and verify that the Gain Control is set correctly. Another possibility is damaged speakers or under-powered speakers. Once again refer to Troubleshooting for additional help.

TROUBLESHOOTING

Problem

No Audio.

Solution

Low or no remote turn-on voltage. Check remote connections at amplifier and source unit.

Blown amplifier fuse. Replace with new fast-blow fuse (same rating).

Power wires not connected. Check battery and ground wiring at amplifier; also check battery connections.

Speaker leads shorted. Check speaker continuity to ground, it should not show a common ground.

Speakers not connected or are blown. Check speaker connections at amplifier, measure coil impedance.

Problem

Audio cycles on and off.

Solution

Thermal protection circuits are shutting amplifier off. Check location for adequate ventilation; consult an authorized Clarion Audio Dealer.

Problem

Distorted audio.

Solution

Gain is not set properly, or damaged speaker cones. Review Setting Gain; inspect each speaker cone for signs of damage (i.e. frozen cone, burning smell, etc.)

Clarion DPX1001.2 Power System Amplifier

Problem

Audio lacks punch.

Solution

Speakers wired incorrectly, which causes cancellation of bass frequencies. Check polarity of wires from amplifier to each speaker as defined by the system design.

Problem

Amplifier fuse keeps blowing.

Solution

Incorrect wiring or short circuit. Review Installation and check all wiring connections.

Problem

Whining or ticking noise in the audio with engine on.

Solution

Amplifier is picking up alternator noise or radiated noise. Turn down input gain; move audio cables away from power wires. Check power and ground connections on amplifier; install an in-line noise filter on source unit's power wire; check alternator and/or voltage regulator; test for weak battery or add water to battery.

PRODUCT SPECS

Frequency Response	20Hz ~ 20kHz
Signal Noise Ratio	>95db
THD	.2% all channels driven
Input Sensitivity Low Level	250mV ~ 2.5 V
Input Sensitivity Speaker Level	500mV - 5V
Max. Power Output	500 watts x 2 @1 ohm
Cont. Power Output	150 watts x 2 into 4 ohms @ <1% THD
2-Ohm Stereo Output	300 watts x 2 into 2 ohms @ <1% THD
Bridged Power	1000 watts x 1 into 2 ohms @ <1% THD
Dimensions	2 1/8" H x 8 1/4" W x 14" L
Current Consumption at output @ max power	86A @ 1000 Watts

WARRANTY INFORMATION

This product is warranted against all defects in material workmanship for a period of one year from the date of original purchase. Clarion ProAudio products except for speakers are covered by a two year warranty when installed by an authorized Clarion dealer. The conditions of this warranty and the extent of responsibility of Clarion Corporation under this warranty are as follows:

1. PROOF OF DATE OF PURCHASE WILL BE REQUIRED FOR WARRANTY SERVICE OF THIS PRODUCT. IN CASE OF 2 YEAR WARRANTY FOR CLARION PROAUDIO PRODUCT, PROOF OF INSTALLATION BY AUTHORIZED DEALER IS REQUIRED. INFORMATION ABOUT CLARION AUTHORIZED WARRANTY SERVICE CENTERS MAY BE OBTAINED BY CONTACTING OR WRITING CLARION CORPORATION AT THE ADDRESS LISTED BELOW.
2. This warranty will become void if service performed by anyone other than an approved Clarion Warranty Service Center results in damage to product.
3. This warranty does not apply to any product which has been subject to misuse, neglect or accident, or which has had the serial number altered, defaced or removed, or which has been connected, installed, adjusted or repaired, other than in accordance with the instructions furnished by Clarion Corporation.
4. This warranty does not cover car static or other electrical interferences, tape head cleaning or adjustments, or labor costs for the removal or reinstallation of the unit for repair.
5. The sole responsibility of Clarion Corporation under this Warranty shall be limited to the repair or replacement thereof, at the sole discretion of Clarion Corporation.
6. If it becomes necessary to send the product or any defective part to Clarion Corporation or an authorized warranty service station, the product must be shipped in its original carton or equivalent carton, fully insured, with shipping charges prepaid. Clarion Corporation will not assume any responsibility for any loss or damage incurred in shipping.
7. ALL IMPLIED WARRANTIES EXCEPT TO THE EXTENT PROHIBITED BY APPLICABLE LAW SHALL HAVE NO GREATER DURATION THAN THE WARRANTY PERIOD SET FORTH ABOVE. UNDER NO CIRCUMSTANCES SHALL CLARION CORPORATION BE LIABLE FOR ANY LOSS OR DAMAGE, DIRECT OR CONSEQUENTIAL, ARISING OUT OF THE USE OR INABILITY TO USE THE PRODUCT. BECAUSE SOME STATES DO NOT ALLOW LIMITATIONS ON HOW LONG AN IMPLIED WARRANTY LASTS OR EXCLUSIONS OR LIMITATIONS OF INCIDENTAL OR CONSEQUENTIAL DAMAGES, THE ABOVE LIMITATIONS OR EXCLUSIONS MAY NOT APPLY TO YOU.
8. THIS WARRANTY GIVES YOU SPECIFIC LEGAL RIGHTS, AND YOU MAY ALSO HAVE OTHER RIGHTS WHICH VARY FROM STATE TO STATE.
9. For instructions on how to obtain warranty service, please call 1-800-GO-CLARION or visit our web site at www.clarion.com for a listing of Authorized Warranty Service Centers in your area, or contact the Clarion Customer Service Manager at the address listed below:

Clarion Corporation of America
661 W. Redondo Beach Blvd.
Gardena, CA 90247-4201 U.S.A.
Tel 1.800.GO.CLARION
www.clarion.com



Clarion Corporation of America
661 W. Redondo Beach Blvd.
Gardena, CA 90247-4201 U.S.A.
Tel 1.800.GO.CLARION
www.clarion.com