

Smart choice for power

xantrex

**RS232-XHR
RS232-XFR
RS232-XFR3**

Operating Manual

**Internal RS-232 Interface
for XHR/XFR Series
Programmable DC Power
Supplies**

www.xantrex.com



Operating Manual for

**Internal RS-232 Interface
for XHR 1000 Watt Series,
XFR 1200 Watt Series and
XFR 2800 Watt Series**

**Programmable DC
Power Supplies**

Limited Warranty

What does this warranty cover and how long does it last?

This Limited Warranty is provided by Xantrex Technology, Inc. (“Xantrex”) and covers defects in workmanship and materials in your **RS-232 Interface Card**. This warranty lasts for a Warranty Period of **5 years** from the date of purchase at point of sale to you, the original end user customer.

What will Xantrex do?

Xantrex will, at its option, repair or replace the defective product free of charge, provided that you notify Xantrex of the product defect within the Warranty Period, and provided that Xantrex through inspection establishes the existence of such a defect and that it is covered by this Limited Warranty.

Xantrex will, at its option, use new and/or reconditioned parts in performing warranty repair and building replacement products. Xantrex reserves the right to use parts or products of original or improved design in the repair or replacement. If Xantrex repairs or replaces a product, its warranty continues for the remaining portion of the original Warranty Period or 90 days from the date of the return shipment to the customer, whichever is greater. All replaced products and all parts removed from repaired products become the property of Xantrex.

Xantrex covers both parts and labor necessary to repair the product, and return shipment to the customer via a Xantrex-selected non-expedited surface freight within the contiguous United States and Canada. Alaska and Hawaii are excluded. Contact Xantrex Customer Service for details on freight policy for return shipments outside of the contiguous United States and Canada.

How do you get service?

If your product requires troubleshooting or warranty service, contact your merchant. If you are unable to contact your merchant, or the merchant is unable to provide service, contact Xantrex directly at:

Phone:	604 422 8595
Toll Free North America:	1 800 667 8422
Fax:	604 421 3056
Email:	info@xantrex.com

Direct returns may be performed according to the Xantrex Return Material Authorization Policy described in your product manual. For some products, Xantrex maintains a network of regional Authorized Service Centers. Call Xantrex or check our website to see if your product can be repaired at one of these facilities.

In any warranty claim, dated proof of purchase must accompany the product and the product must not have been disassembled or modified without prior written authorization by Xantrex.

Proof of purchase may be in any one of the following forms:

- The dated purchase receipt from the original purchase of the product at point of sale to the end user, or
- The dated dealer invoice or purchase receipt showing original equipment manufacturer (OEM) status, or
- The dated invoice or purchase receipt showing the product exchanged under warranty

What does this warranty not cover?

This Limited Warranty does not cover normal wear and tear of the product or costs related to the removal, installation, or troubleshooting of the customer's electrical systems. This warranty does not apply to and Xantrex will not be responsible for any defect in or damage to:

- a. the product if it has been misused, neglected, improperly installed, physically damaged or altered, either internally or externally, or damaged from improper use or use in an unsuitable environment;
- b. the product if it has been subjected to fire, water, generalized corrosion, biological infestations, and high input voltage from lightning strikes;
- c. the product if repairs have been done to it other than by Xantrex or its authorized service centers (hereafter "ASCs");
- d. the product if it is used as a component part of a product expressly warranted by another manufacturer;
- e. the product if its original identification (trade-mark, serial number) markings have been defaced, altered, or removed.

Disclaimer Product

THIS LIMITED WARRANTY IS THE SOLE AND EXCLUSIVE WARRANTY PROVIDED BY XANTREX IN CONNECTION WITH YOUR XANTREX PRODUCT AND IS, WHERE PERMITTED BY LAW, IN LIEU OF ALL OTHER WARRANTIES, CONDITIONS, GUARANTEES, REPRESENTATIONS, OBLIGATIONS AND LIABILITIES, EXPRESS OR IMPLIED, STATUTORY OR OTHERWISE IN CONNECTION WITH THE PRODUCT, HOWEVER ARISING (WHETHER BY CONTRACT, TORT, NEGLIGENCE, PRINCIPLES OF MANUFACTURER'S LIABILITY, OPERATION OF LAW, CONDUCT, STATEMENT OR OTHERWISE), INCLUDING WITHOUT RESTRICTION ANY IMPLIED WARRANTY OR CONDITION OF QUALITY, MERCHANTABILITY OR FITNESS FOR A PARTICULAR PURPOSE. ANY IMPLIED WARRANTY OF MERCHANTABILITY OR FITNESS FOR A PARTICULAR PURPOSE TO THE EXTENT REQUIRED UNDER APPLICABLE LAW TO APPLY TO THE PRODUCT SHALL BE LIMITED IN DURATION TO THE PERIOD STIPULATED UNDER THIS LIMITED WARRANTY.

IN NO EVENT WILL XANTREX BE LIABLE FOR ANY SPECIAL, DIRECT, INDIRECT, INCIDENTAL OR CONSEQUENTIAL DAMAGES, LOSSES, COSTS OR EXPENSES HOWEVER ARISING WHETHER IN CONTRACT OR TORT INCLUDING WITHOUT RESTRICTION ANY ECONOMIC LOSSES OF ANY KIND, ANY LOSS OR DAMAGE TO PROPERTY, ANY PERSONAL INJURY, ANY DAMAGE OR INJURY ARISING FROM OR AS A RESULT OF MISUSE OR ABUSE, OR THE INCORRECT INSTALLATION, INTEGRATION OR OPERATION OF THE PRODUCT.

Exclusions If this product is a consumer product, federal law does not allow an exclusion of implied warranties. To the extent you are entitled to implied warranties under federal law, to the extent permitted by applicable law they are limited to the duration of this Limited Warranty. Some states and provinces do not allow limitations or exclusions on implied warranties or on the duration of an implied warranty or on the limitation or exclusion of incidental or consequential damages, so the above limitation(s) or exclusion(s) may not apply to you. This Limited Warranty gives you specific legal rights. You may have other rights which may vary from state to state or province to province.

Information WITHOUT LIMITING THE GENERALITY OF THE FOREGOING, UNLESS SPECIFICALLY AGREED TO BY IT IN WRITING, XANTREX

- a. MAKES NO WARRANTY AS TO THE ACCURACY, SUFFICIENCY OR SUITABILITY OF ANY TECHNICAL OR OTHER INFORMATION PROVIDED IN MANUALS OR OTHER DOCUMENTATION PROVIDED BY IT IN CONNECTION WITH THE PRODUCT; AND
- b. ASSUMES NO RESPONSIBILITY OR LIABILITY FOR LOSSES, DAMAGES, COSTS OR EXPENSES, WHETHER SPECIAL, DIRECT, INDIRECT, CONSEQUENTIAL OR INCIDENTAL, WHICH MIGHT ARISE OUT OF THE USE OF SUCH INFORMATION.

THE USE OF ANY SUCH INFORMATION WILL BE ENTIRELY AT THE USER'S RISK.

WARNING: Please refer to your product user manual for limitations on uses of the product.
Limitations on Use Specifically, please note that this power supply is not intended for use in connection with life support systems and Xantrex makes no warranty or representation in connection with any use of the product for such purposes.

Xantrex Technology, Inc.
8999 Nelson Way
Burnaby, British Columbia
Canada V5A 4B5

Information About Your Power Supply Please record the following information when you first open your Power Supply package:

Model Number	_____
Serial Number	_____
Purchased From	_____
Purchase Date	_____

Release Release 3.1 (2002-06)

Copyright © 2002 Xantrex Technology Inc. All rights reserved.
Printed in Canada

Power Supply Safety



WARNING—High Energy and High Voltage

Exercise caution when using and calibrating a power supply. High energy levels can be stored at the output voltage terminals on a power supply in normal operation. In addition, potentially lethal voltages exist in the power circuit and on the output and sense connectors of a power supply with a rated output greater than 40 V. Filter capacitors store potentially dangerous energy for some time after power is removed.



CAUTION

Operate the power supply in an environment free of flammable gases or fumes. To ensure that the power supply's safety features are not compromised, use the power supply as specified in this manual and do not substitute parts or make any unauthorized modifications. Contact the service technician for service and repair help. Repairs must be made by experienced service technicians only.

Warnings, Cautions, and Notes

Warnings, cautions, and notes are defined and formatted in this manual as shown below.



WARNING

Describes a potential hazard which could result in injury or death, or, a procedure which, if not performed correctly, could result in injury or death.



CAUTION

Describes a procedure which, if not performed correctly, could result in damage to data, equipment, or systems.

Note

Describes additional operating information which may affect the performance of the equipment.

About This Manual

This technical manual is for the RS-232 Interface; a microprocessor-controlled option card for all models of XFR Series and XHR Series DC output power supplies. This manual provides you with specifications, user options, and configuration instructions for the interface, along with a command set which allows you to control your power supply from a computer console. Error messages and calibration procedures are also included.

This manual is designed for the user who is familiar with basic electrical theory especially as it applies to the operation of power supplies. This implies a recognition of Constant Voltage and Constant Current operation modes and the control of input and output power, as well as the observance of safe techniques while effecting supply or pin connections and any changes in switch settings. The user should also have experience with a computer-based communications software package.

Refer to your power supply manual for installation, configuration, and operating procedures for your power supply.

Main Sections

Section 1 Features and Specifications Describes the interface and lists its features and specifications.

Section 2 Installation and Configuration Goes through basic setup procedures. Describes inspection, cleaning, shipping, and storage procedures.

Section 3 Operation Lists the complete command set, status registers, and error codes.

Section 4 Calibration Provides detailed procedures for voltage and current mode calibration as well as over voltage protection (OVP) calibration. Includes calibration for programming and readback accuracy.

Manual Revisions

The current release of this manual is listed below. Updates may be issued as an addendum.

Release 3.1 (2002-06)

About This Manual

Contents

	About This Manual	vii
Section 1.	Description	11
Features and Specifications	Features and Functions	12
	Features	12
	Programmable Functions	12
	Readback Functions	12
	Specifications	13
Section 2.	Introduction	19
Installation and Configuration	Initial Inspection	19
	Basic Setup Procedure	23
	Communications	24
	Baud Rate Selection	24
	Flow Control Selection	24
	Software Flow Control	25
	Hardware Flow Control	25
	Connections	26
	Transmit / Receive Pin Selection	26
	Remote/Local Operation	27
	Remote / Local Mode Startup	27
	Remote Mode Operation	28
	Local Mode Operation	29
	Remote Enable (REN) Command	29
	Local Lockout (LLO) Command	30
	RS-232 Connection	30
	Power Supply Settings	31
	User Options and Settings	32
	OVP Selection	32
	TTL Shutdown	33
	User Signals	34
	Connector J7 User Signals	34
	J7 Cable Connection	35
Section 3.	Introduction	37
Operation	RS-232 Operation	37
	Command Syntax	37
	Manual Conventions	37
	Command Format and Parameters	38
	Command Strings	39
	Command Terminators	40
	Order	40
	Command Summary	41

Contents

Command Reference	44
Accumulated Status, Status, and Fault Registers	51
Error Codes	53
Troubleshooting	54
Diagnostic LEDs	54

Section 4. Calibration

Introduction	55
Voltage Mode Calibration	56
Voltage Calibration Setup	56
Voltage Program Calibration Procedure	56
Voltage Readback Calibration Procedure	57
Current Mode Calibration	58
Current Calibration Setup	58
Current Program Calibration Procedure	58
Current Readback Calibration Procedure	59
Over Voltage Protection (OVP) Calibration	60

Section 1. Features and Specifications

Description

The RS-232 Interface is a microprocessor-controlled option card for all models of the XHR series and XFR series of DC output power supply. Installed internally, the RS-232 interface card gives you remote digital control of simple test systems. It features fast, 16-bit resolution for programming and readback and uses bit serial protocol for sending data between the computer and the interface. The RS-232 interface has an extensive command set and uses most of the user-programmable features employed by all of our interfaces.

In addition to the RS-232 port and its interface, this remote control application requires a computer-based communications software package such as PROCOMM, XTALK, Windows Terminal Program, equivalent communications software, or low level or high level language programs. The RS-232 interface is an ideal tool for reliable, remote power supply control of both research and development applications.

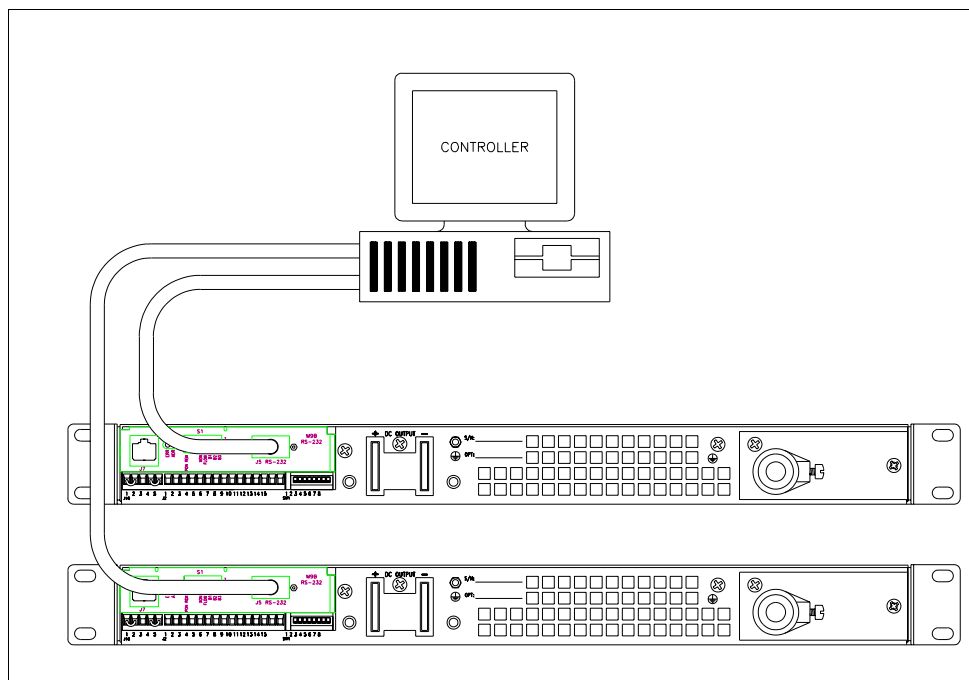

Figure 1.1 Sample Configuration using RS232 Interface
(1200 Watt DC Power Supplies Shown)

Features and Specifications

Features and Functions

Features and Functions

- Features**
- 16-bit programming and readback of voltage and current
 - Programmable soft limits for voltage and current
 - Programmable over voltage protection with reset
 - Easy-to-use, self-documenting command set
 - Standardized commands for complete communication with any of the supplies in the system
 - User-programmable isolated fault, polarity, isolation, and auxiliary, user-defined output signals.
 - LED status signals: error, address, remote/local operation, and over voltage protection.
 - Foldback in CV or CC mode with reset
 - Software calibration

- Programmable Functions**
- Output voltage and current
 - Soft limits for voltage and current
 - Over voltage protection
 - Output enable/disable
 - Maskable fault interrupt
 - Hold and trigger
 - Output relay signals

- Readback Functions**
- Actual voltage and current
 - Voltage and current settings
 - Soft voltage and current limits
 - Over voltage protection setting
 - Present and accumulated power supply status
 - Programming error codes
 - Fault codes
 - Power supply model and software version identification

Specifications

The specifications in this section are warranted at 25°C ±5°C unless otherwise specified. All specifications are subject to change without notice.

Table 1.1 Specifications for XFR 1200 W Series Supply with RS-232 Interface Installed (7.5 V to 40 V)

Models	7.5-140	12-100	20-60	35-35	40-30
Program Resolution					
Voltage	1.2mV	3.1mV	5.1mV	5.4mV	6.2mV
Current	18.3mA	7.1mA	4.7mA	5.4mA	3.6mA
OVP	1.2mV	3.1mV	5.1mV	5.4mV	6.2mV
Program Accuracy¹					
Voltage	10mV	75mV	75mV	75mV	75mV
	±0.12%	±0.12%	±0.12%	±0.3%	±0.3%
Current	500mA	250mA	165mA	200mA	140mA
	±0.1%	±0.1%	±0.15%	±0.1%	±0.15%
OVP	80mV	200mV	330mV	350mV	400mV
Readback Resolution					
Voltage	1.2mV	3.1mV	5.1mV	5.4mV	6.2mV
Current	18.3mA	7.1mA	4.7mA	5.4mA	3.6mA
Readback Accuracy¹					
Voltage	30mV	75mV	75mV	75mV	75mV
	±0.12%	±0.12%	±0.2%	±0.3%	±0.3%
Current	500mA	250mA	165mA	200mA	140mA
	±0.1%	±0.1%	±0.15%	±0.1%	±0.15%

1. Apply accuracy specifications according to the following voltage program accuracy example:
Set a model 20-60 power supply to 10 volts.
The expected result will be within the range of 10 volts ± 75mV ± 0.12% of the set voltage of 10 volts.

Features and Specifications

Specifications

Table 1.2 Specifications for XFR 1200 W Series Supply with RS-232 Interface Installed (60 V to 600 V)

Models	60-20	100-12	150-8	300-4	600-2
Program Resolution					
Voltage	9.3mV	15.5mV	23.2mV	46.4mV	92.7mV
Current	2.6mA	1.5mA	1.0mA	0.5mA	0.3mA
OVP	9.3mV	15.5mV	23.2mV	46.4mV	92.7mV
Program Accuracy¹					
Voltage	150mV ±0.25%	150mV ±0.35%	225mV ±0.35%	225mV ±0.35%	300mV ±0.35%
Current	120mA ±0.1%	80mA ±0.1%	80mA ±0.1%	80mA ±0.1%	75mA ±0.1%
OVP	600mV	1.0V	1.5V	3.0V	6V
Readback Resolution					
Voltage	9.3mV	15.5mV	23.2mV	46.4mV	92.7mV
Current	2.6mA	1.5mA	1.0mA	0.5mA	0.3mA
Readback Accuracy¹					
Voltage	150mV ±0.25%	150mV ±0.35%	225mV ±0.35%	225mV ±0.35%	300mV ±0.35%
Current	120mA ±0.1%	80mA ±0.1%	80mA ±0.1%	80mA ±0.1%	75mA ±0.1%

1. Apply accuracy specifications according to the following voltage program accuracy example:

Set a model 20-60 power supply to 10 volts.

The expected result will be within the range of 10 volts ± 75mV ± 0.12% of the set voltage of 10 volts.

Table 1.3 Specifications for XFR 2800 W Series Supply with RS-232 Interface Installed (7.5 V to 40 V)

Models	7.5-300	12-220	20-130	33-85	40-70
Program Resolution					
Voltage	1.2mV	3.1mV	5.1mV	5.1mV	6.2mV
Current	11.3mA	4.3mA	2.6mA	13.0mA	2.2mA
OVP	1.2mV	3.1mV	5.1mV	5.1mV	6.2mV
Program Accuracy¹					
Voltage	10mV ±0.12%	75mV ±0.12%	75mV ±0.12%	75mV ±0.3%	75mV ±0.3%
Current	300mA ±0.15%	165mA ±0.15%	120mA ±0.15%	425mA ±0.1%	110mA ±0.15%
OVP	75mV	200mV	330mV	330mV	400mV
Readback Resolution					
Voltage	1.2mV	3.14mV	5.1mV	5.1mV	6.2mV
Current	11.3mA	4.3mA	2.6mA	13.0mA	2.2mA
Readback Accuracy¹					
Voltage	10mV ±0.12%	75mV ±0.12%	75mV ±0.2%	75mV ±0.3%	75mV ±0.3%
Current	300mA ±0.15%	165mA ±0.15%	120mA ±0.15%	425mA ±0.1%	110mA ±0.15%

- Apply accuracy specifications according to the following voltage program accuracy example:
Set a model 20-130 power supply to 10 volts.
The expected result will be within the range of 10 volts ± 75mV ± 0.12% of the set voltage of 10 volts.

Features and Specifications

Specifications

Table 1.4 Specifications for XFR 2800 W Series Supply with RS-232 Interface Installed (60 V to 600 V)

Models	60-46	100-28	150-18	300-9	600-4
Program Resolution					
Voltage	9.3mV	15.5mV	23.2mV	46.4mV	92.7mV
Current	1.4mA	0.9mA	0.6mA	0.3mA	0.2mA
OVP	9.3mV	15.5mV	23.2mV	46.4mV	92.7mV
Program Accuracy¹					
Voltage	150mV ±0.3%	150mV ±0.35%	225mV ±0.35%	225mV ±0.35%	300mV ±0.35%
Current	80mA ±0.1%	80mA ±0.1%	80mA ±0.1%	75mA ±0.1%	75mA ±0.1%
OVP	600mV	1.0V	1.5V	3.0V	6V
Readback Resolution					
Voltage	9.3mV	15.5mV	23.2mV	46.4mV	92.7mV
Current	1.4mA	0.9mA	0.6mA	0.3mA	0.2mA
Readback Accuracy¹					
Voltage	150mV ±0.3%	150mV ±0.35%	225mV ±0.35%	225mV ±0.35%	300mV ±0.35%
Current	80mA ±0.1%	80mA ±0.1%	80mA ±0.1%	75mA ±0.1%	75mA ±0.1%

1. Apply accuracy specifications according to the following voltage program accuracy example:
Set a model 20-130 power supply to 10 volts.
The expected result will be within the range of 10 volts ± 75mV ± 0.12% of the set voltage of 10 volts

Table 1.5 Specifications for XHR 1000 W Series Supply with RS-232 Interface Installed (7.5 V to 60 V)

Models	7.5-130	20-50	33-33	40-25	60-18
Program Resolution					
Voltage	1.2mV	3.1mV	5.1mV	6.2mV	9.3mV
Current	18.3mA	7.1mA	4.7mA	3.6mA	2.6mA
OVP	1.2mV	3.1mV	5.1mV	6.2mV	9.3mV
Program Accuracy¹					
Voltage	10mV ±0.12%	75mV ±0.12%	75mV ±0.12%	75mV ±0.3%	150mV ±0.25%
Current	500mA ±0.1%	250mA ±0.1%	165mA ±0.1%	140mA ±0.15%	120mA ±0.1%
OVP	80mV	200mV	330mV	400mV	600mV
Readback Resolution					
Voltage	1.2mV	3.1mV	5.1mV	6.2mV	9.3mV
Current	18.3mA	7.1mA	4.7mA	3.6mA	2.6mA
Readback Accuracy¹					
Voltage	30mV ±0.12%	75mV ±0.12%	75mV ±0.2%	75mV ±0.3%	150mV ±0.25%
Current	500mA ±0.1%	250mA ±0.1%	165mA ±0.15%	140mA ±0.15%	120mA ±0.1%

1. Apply accuracy specifications according to the following voltage program accuracy example:
Set a model 20-50 power supply to 10 volts.
The expected result will be within the range of 10 volts ± 50mV ± 0.12% of the set voltage of 10 volts.

Features and Specifications

Specifications

Table 1.6 Specifications for XHR 1000 W Series Supply with RS-232 Interface Installed (100 V to 600 V)

Models	100-10	150-7	300-3.5	600-1.7
Program Resolution				
Voltage	15.5mV	23.2mV	46.4mV	92.7mV
Current	1.5mA	1.0mA	0.5mA	0.3mA
OVP	15.5mV	23.2mV	46.4mV	92.7mV
Program Accuracy¹				
Voltage	150mV ±0.35%	225mV ±0.35%	225mV ±0.35%	300mV ±0.35%
Current	80mA ±0.1%	80mA ±0.1%	80mA ±0.1%	75mA ±0.1%
OVP	1.0V	1.5V	3.0V	6V
Readback Resolution				
Voltage	15.5mV	23.2mV	46.4mV	92.7mV
Current	1.5mA	1.0mA	0.5mA	0.3mA
Readback Accuracy¹				
Voltage	150mV ±0.35%	225mV ±0.35%	225mV ±0.35%	300mV ±0.35%
Current	80mA ±0.1%	80mA ±0.1%	80mA ±0.1%	75mA ±0.1%

1. Apply accuracy specifications according to the following voltage program accuracy example:
Set a model 20-50 power supply to 10 volts.
The expected result will be within the range of 10 volts ± 50mV ± 0.12% of the set voltage of 10 volts.

Section 2. Installation and Configuration

Introduction

To use this product, you must have the following equipment:

- a compatible model of DC output power supply
- serial extender cable (straight through)
- computer with an RS-232 interface (serial port)
- computer-based communications software package

The RS-232 interface is usually installed at the factory. Your local distributor or service center can also install the interface, especially for use in a previously-purchased supply already on site. You must then configure the RS-232 Interface-enhanced supply for your system using the “Basic Setup Procedure” on page 23. Refer also to Figure 2.1, on page 20, Figure 2.2, on page 21 and Figure 2.3, on page 22 for drawings of the front panel, the interface subplate, and the RS-232 interface printed circuit board (PCB).

Initial Inspection



CAUTION

If you remove the unit's cover, use proper static control techniques to avoid damage to static-sensitive components on the printed circuit board.

On first receiving your unit, perform a quick physical check.

- Ensure each package contains a power supply with its RS-232 interface board installed, and manuals for the power supply and the RS-232 interface. Any additional parts shipped with the power supply will be identified in the supply's documentation.
- Inspect the unit for any signs of physical damage such as scratches, cracks, or broken switches, connectors, or displays.
- Check the printed circuit board and components if you suspect internal damage.

If the unit is damaged, save all packing materials and notify the carrier immediately. For additional information, please see the section titles, “Returning Power Supplies to the Manufacturer” in the manual shipped with your complete unit.

Installation and Configuration

Initial Inspection



CAUTION

Use proper static control techniques to avoid damage to static-sensitive components on the printed circuit board.

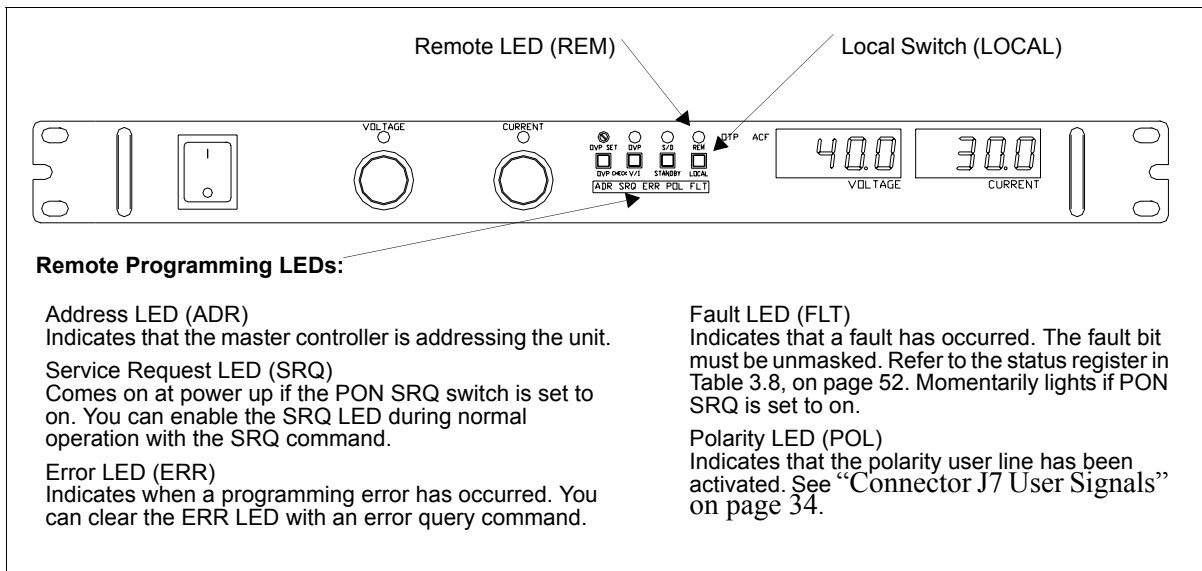

Figure 2.1 Power Supply Front Panel with RS-232 Interface Installed (1200 Watt Power Supply Shown)

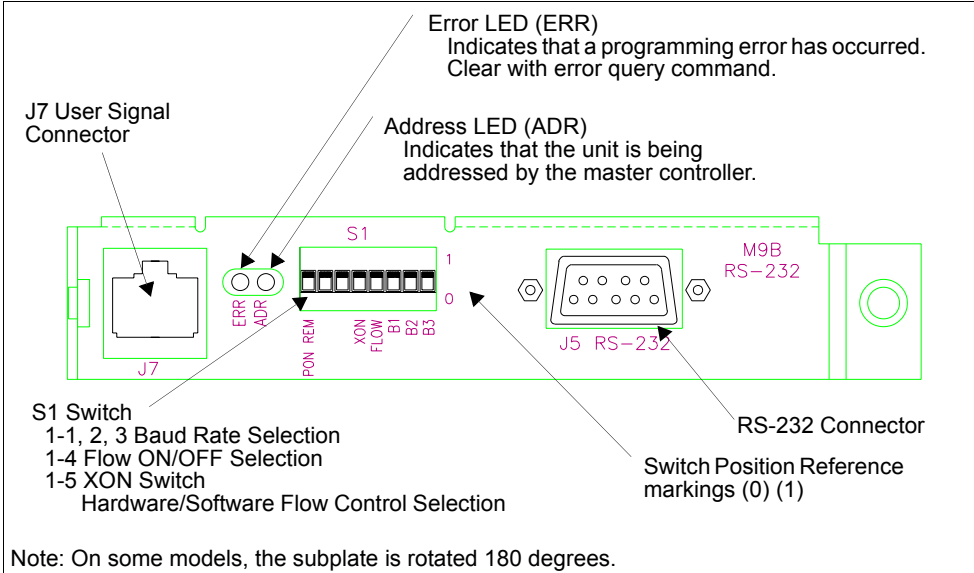

Figure 2.2 RS-232 Interface Subplate
(Located on Power Supply Rear Panel)



CAUTION

Use proper static control techniques to avoid damage to static-sensitive components on the printed circuit board

Installation and Configuration

Initial Inspection

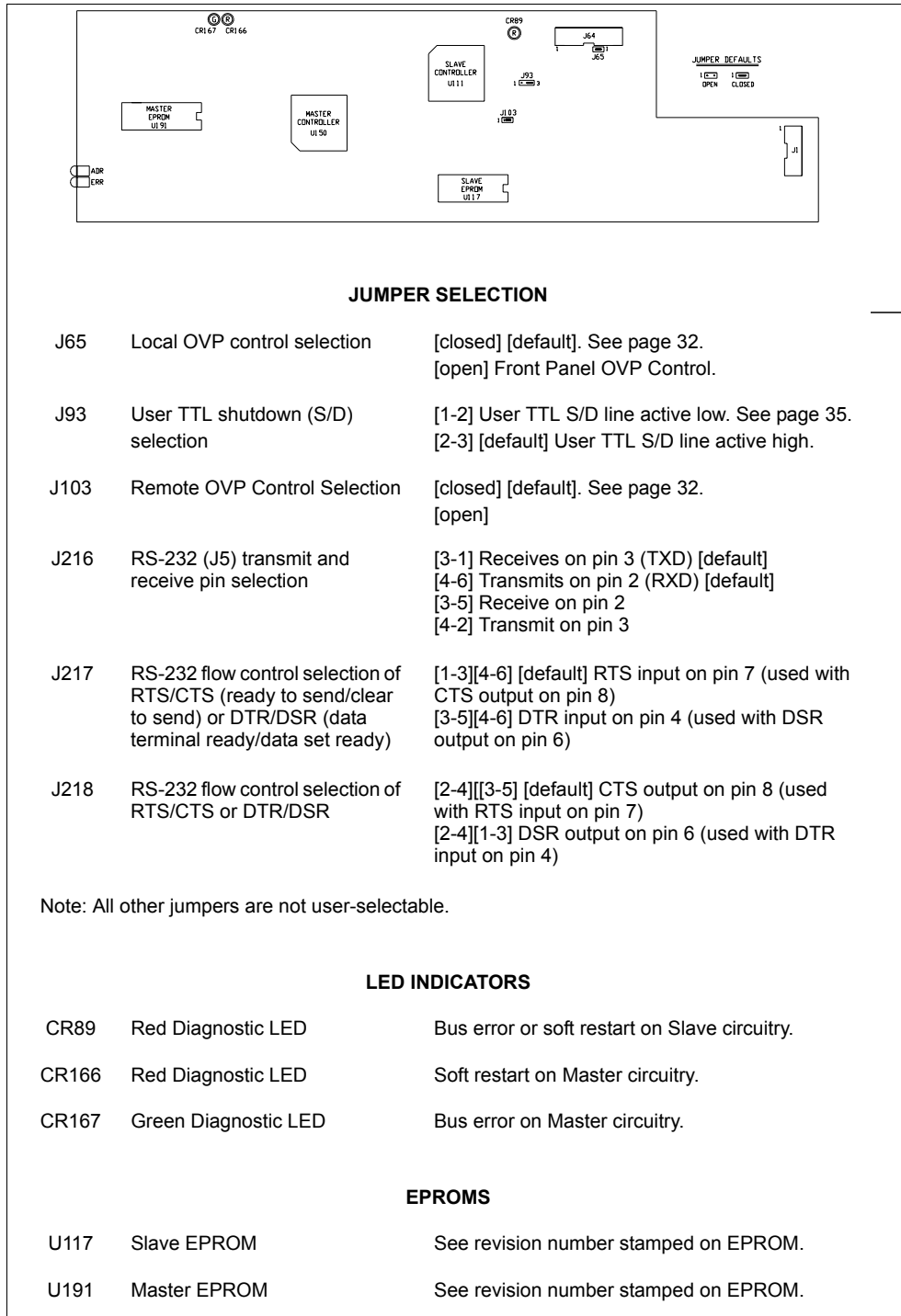

Figure 2.3 RS-232 Interface PCB

Basic Setup Procedure

This procedure can be used as a quick reference for those familiar with the configuration requirements for the RS-232 interface as installed in the DC power supply. For those who want more information, each step refers to more detailed procedures located in subsequent sections. Execute each step of the procedure in the sequence given.

Table 2.1 Setup Procedure

Step #	Description	Action	Reference
1	Baud Rate Selection	Select transmission speed	See “Baud Rate Selection” on page 24.
2	Flow Control Selection	Set flow control ON or OFF. If flow control is set ON, choose software-based XON/XOFF or hardware-based CTS/RTS (Clear to Send/Ready to Send) or DTR/DSR (Data Terminal Ready/Data Set Ready) communication control.	“Flow Control Selection” on page 24.
3	Remote/Local Operation	Use the rear panel PON REM switch to select remote or local startup of the power supply.	See “Remote/Local Operation” on page 27.
4	RS-232 Connection	Connect the RS-232 cable assembly to the supply at connector J5.	See “RS-232 Connection” on page 30
5	User Signal Connector	Configure and use the J7 connector signals, if required.	See “Connector J7 User Signals” on page 34.
6	Power ON	Power on the unit. Before proceeding, check to ensure that the green REM LED on the front panel is on.	See “User Options and Settings” on page 32 and “User Signals” on page 34 for information about Local/Remote OVP, TTL Shutdown, and auxiliary connector J7 user signals.
7	Power Supply Settings	Configure the controller’s operating parameters to match the power supply settings.	See “Power Supply Settings” on page 31.
8	Test	Test the link by communicating with the power supply.	Example: VSET2;ISET1 This command string sets power supply voltage to 2V and its current limit to 1A. See Section 3.

Communications

Baud Rate Selection Serial transmission sends and receives data in bit streams at fixed bit rates. Both the computer and the interface must have the same bit rate setting for proper communication. Use switches B1, B2, and B3 on the rear panel S1 switch to select the power supply's rate of transmission in bits per second. Table 2.2, "Switch S1 Settings for Baud Rate" summarizes the switch settings with the reference markings on the rear panel subplate. Refer to Figure 2.2, on page 21 for the location of the S1 switch on the RS-232 interface subplate.

Table 2.2 Switch S1 Settings for Baud Rate

Baud Rate	B3	B2	B1
9600	1	1	1
4800	0	1	1
2400	1	0	1
1200	0	0	1
600	1	1	0
300	0	1	0
150	1	0	0
75	0	0	0

0 = OPEN/OFF 1 = CLOSED/ON

Note: When resetting switches B3, B2, and B1 during a working session, turn the power supply OFF and then ON again to ensure that the new settings are put into effect.

Flow Control Selection Flow control signals regulate data flow for proper communication. Use the FLOW switch on the rear panel S1 switch to select flow control or to disable flow control. With flow control enabled, you can use either software or hardware protocols to control flow rates. Table 2.3 gives the FLOW switch settings with regards to the markings on the subplate rear panel. For a diagram of the rear panel subplate, see Figure 2.2, on page 21.

Table 2.3 Flow Control Section

FLOW Switch Setting	Condition
1	Disable Flow Control
0	Enable Flow Control

Once flow control is selected as option, two flow control methods are available. You can use the rear panel XON switch to select either software-based XON/XOFF flow protocol or hardware-based CTS/RTS or DTR/DSR flow protocol. Table 2.4 shows the flow control conditions with regards to the markings on the rear panel subplate. For a diagram of the rear panel subplate, see Figure 2.2, on page 21.

Table 2.4 Hardware/Software Flow Control Selection

XON Switch Setting	Condition
1	Hardware Flow Control (CTS/RTS or DTR/DSR protocol)
0	Software Flow Control (XON/XOFF protocol)

Software Flow Control

This software protocol uses special characters that synchronize device communications. The device sends the control code XOFF (ASCII value 13 hex) when it is not ready to receive data. The device sends the control code XON (ASCII value 11) when it is ready to resume receiving data.

To choose XON/XOFF protocol, select the XON switch position shown in Table 2.4.

Hardware Flow Control

Hardware flow control protocol requires a dedicated control line on the RS-232 cable. The dedicated control line is needed so that the device can signal the controller when it is ready to receive data. You can designate either RTS/CTS or DTR/DSR protocol for the RS-232 interface.

Set the XON switch for hardware control using the information in Table 2.4. With hardware flow control selected, RS-232 Interface PCB jumpers J217 and J218 dictate the type of flow protocol. Table 2.5, “Jumper/Pin Settings for RTS/CTS Flow Control (Default)” and Table 2.6, “Jumper/Pin Settings for DTR/DSR Flow Control (Default)” identify jumper connections and input and output pin designations for each protocol. See also “Transmit / Receive Pin Selection” on page 26 for RS-232 connector pinouts.

Note: When resetting the flow control switches during a working session, turn the power supply OFF and then ON again to ensure that the new settings are put into effect.

Table 2.5 Jumper/Pin Settings for RTS/CTS Flow Control (Default)

	Jumper Connections	RS-232 Connector Pin
RTS (Input to RS-232)	J218 to 2-4 and 3-5	7
CTS (Output to RS-232)	J217 to 1-3 and 4-6	8

Table 2.6 Jumper/Pin Settings for DTR/DSR Flow Control (Default)

	Jumper Connections	RS-232 Connector Pin
DTR (Input to RS-232)	J218 to 2-4 and 1-3	4
DSR (Output to RS-232)	J217 to 3-5 and 4-6	6

Connections

Use a 9-pin (DB9) to 9-pin parallel cable to connect the interface card to the serial port on the host computer. If you need to use a 25-pin connector (DB25) on the host interface, ensure the correct connections are made by referring Table 2.7. If the proper cables are not available and you need to change the transmit/receive pin configuration, see “Transmit / Receive Pin Selection”.

Table 2.7 Default Transmit/Receive Pin Connections

Power Supply (DCE)		Host Computer (DTE)
9-pin connector		
Pin 2	transmits to	Pin 2 (Receive)
Pin 3	receives from	Pin 3 (Transmit)
Pin 5 (Ground)	connects to	Pin 5 (Ground)
25-pin connector		
Pin 2	transmits to	Pin 3 (Receive)
Pin 3	receives from	Pin 2 (Transmit)
Pin 5 (Ground)	connects to	Pin 7 (Ground)

Transmit / Receive Pin Selection

The RS-232 interface can use either pin 2 or pin 3 of the RS-232 connector to transmit or receive data. You can set the pin orientation you want by changing the position of the J216 jumper on the interface PCB. Table 2.8 shows the transmit/receive pin selection on the RS-232 connector in relation to the settings of the J216 jumper. See Figure 2.3, “RS-232 Interface PCB” on page 22 to locate jumper J216.

Table 2.8 Jumper Settings for Transmit/Receive Pin Selection

	Jumper J216 Connections	RS-232 Connector Pin
Transmit (TXD)	4-6 (default)	3
	4-2	2
Receive (RXD)	3-1 (default)	2
	3-5	3

Remote/Local Operation

Remote / Local Mode Startup

Start the power supply either in local mode or in remote mode by setting the power ON remote (PON REM) switch which is located on the unit's rear panel. See Table 2.9 for the switch settings.

Table 2.9 Remote/Local Start-up Settings.

Switch Position	Power ON results
0	Unit in remote mode
1	Unit in local mode

With the rear panel PON REM switch set to 0, the power supply will start up in remote mode. The green REM LED on the front panel will turn on, signaling that the power supply is under the control of the digital interface card. The output of the power supply is active on startup. To promote load safety, power ON defaults are zero for the output voltage and current limit, and 110% of maximum output voltage for the OVP trip point. See Table 2.10. Refer to Section 3 for more information about the interface commands listed in the table.

If the rear panel PON REM switch is set to 1, the power supply will power up in local mode. Power supply control is at the front panel. During an operating session, you can toggle between local mode and remote mode by using the front panel LOCAL button and sending commands as described in Table 2.10.

Installation and Configuration

Remote/Local Operation

Table 2.10 Remote Mode Power On Conditions

Condition	Default Settings	7.5-140 Model Example
Voltage	0 V	VSET 0
Current	0 A	ISET 0
Soft Voltage Limit	VMAX (see models)	VMAX 7.5
Soft Current Limit	IMAX (see models)	IMAX 140
OVP Trip Voltage	Model VMAX + 10%	OVSET 8.25
Delay	0.5 s	DLY 0.5S
Remote Enable	ON	REN ON
Foldback Protection	OFF	FOLD OFF
Output	ON	OUT ON
Hold	OFF	HOLD OFF
Unmask	NONE	UNMASK NONE
AUXA	OFF	AUXA OFF
AUXB	OFF	AUXB OFF

Remote Mode Operation

While in remote mode, use the interface commands to control the output of the power supply from a computer. See Section 3 for a complete list of device-dependent commands available with this interface.

From remote mode, change to local mode operation by pressing the front panel LOCAL button or by sending either the GTL (Go to Local) command or the REN (Remote Enable) OFF command. You can disable the LOCAL button by using the LLO (Local Lockout) command. For an example of how to use Local Lockout, see “Local Lockout (LLO) Command” on page 30.

To return to remote mode, ensure that the REN command is set to ON and then send any valid device-dependent command. Since the remote mode output settings may be different from the local mode settings, the output is programmed to protect the load by turning off when you toggle from local to remote mode during a session. Check your remote settings and then send OUT ON to restore the output.

Local Mode Operation

In local mode operation, you set the voltage and current output levels and the OVP trip level with controls located on the front panel. Refer to the operating manual for a description of the functions available at the front panel.

While in local mode operation, you can change power supply control to remote mode by ensuring that REN is ON, then sending any software command and OUT ON to restore the output. Return to local mode by pressing the front panel LOCAL button, unless Local Lockout is in effect. If LLO is in effect, use the GTL command to send the power supply into local mode, or use the REN OFF command to turn off LLO and return the power supply to local mode.

Example:

Press the LOCAL button	Set unit to local mode
Id?	Put the unit into remote mode (Use any command to do this.)
Press the LOCAL button	Return to local mode.

Remote Enable (REN) Command

You can use the Remote Enable command to toggle between local mode and remote mode. The default setting at startup is REN ON. With the remote enable command set at REN ON, you can return the power supply to remote mode whenever you send any command from the computer. Any time that you change from local to remote mode during a session, the output is programmed to turn off, since the remote mode settings may be different from the local mode settings. Send the OUT ON command to restore the output.

You can turn off Remote Enable and move power supply control to the front panel by sending the REN OFF command. If the Local Lockout condition is in effect, sending the REN OFF command will turn off the LLO condition before sending the unit into local mode.

To check whether the power supply is remote enabled, use the REN? query command.

Example:

REN ON	Enable the power supply to be sent into remote mode
VSET 10; ISET 2	Put the unit into remote operation mode (Use any command to do this.)

Installation and Configuration

RS-232 Connection

Local Lockout (LLO) Command

Use the Local Lockout command to disable the LOCAL button on the power supply front panel. With LLO in effect, you cannot return to local control by pressing the front panel LOCAL switch. You can still return to local mode by sending the Go to Local (GTL) command. To turn off LLO and return the power supply to local mode, send the REN OFF command. Only the REN OFF command will remove the LLO condition.

Example:

LLO	Set Local Lockout
GTL	Return the power supply to local mode. Local Lockout is still in effect
REN OFF	Turn off Local Lockout and return the power supply to local mode

RS-232 Connection



WARNING

Do not operate the power supply and the computer at significantly different frame potentials. The interface connection system may not be capable of handling the resulting excessive ground currents.

Use an approved RS-232 connector and cable when connecting the RS-232 Interface to your computer. The RS-232 connector uses the 9 pin mating connector J5 on the rear panel. Figure 2.4 shows the connector pinouts for the RS-232 connector. Refer to Figure 2.2, on page 21 for the position of the RS-232 connector on the rear panel subplate.

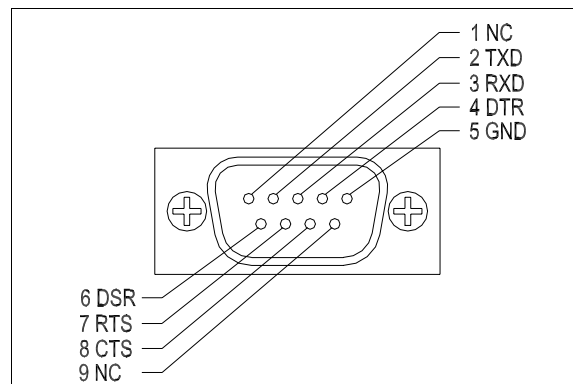

Figure 2.4 RS-232 Connector (J5) Pinouts (default configuration)

Power Supply Settings

For serial communication, the computer and the RS-232 interface must share the same communication settings. Make sure that the settings of the computer and of the power supply agree with those shown in Table 2.11.

Table 2.11 Power Supply Settings

Parameter	Setting
Transmission	Asynchronous
Mode	Full Duplex
Speeds	75, 150, 300, 600, 1200, 2400, 4800, 9600
Parity	None
Connector	DB9-pin Male
Start Bit	1
Stop Bit	1
Data Bits	8
Protocols	XON/XOFF CTS/RTS (DSR/DTR) NONE

User Options and Settings



CAUTION

If you remove the unit's cover, use proper static control techniques to avoid damage to static-sensitive components on the printed circuit board.

You can customize remote operation settings for OVP (over voltage protection) control and TTL shutdown by changing jumper positions on the RS-232 PCB. Refer to the operating manual for information on how to use over voltage protection and TTL shutdown.

OVP Selection

Over voltage protection (OVP) on the RS-232 interface is set at the factory for remote software operation. When operating the power supply in remote mode, you control the OVP trip level using the OVSET software command. If you return the power supply to local operation by using the REN software command or the front panel LOCAL switch, control of the OVP trip level changes from software control to the front panel OVP potentiometer. The default OVP trip level is set as 110% of the power supply's rated output voltage. See Table 2.10, on page 28 for a complete list of remote power ON default settings.

You can isolate the location of OVP control by changing the positions of the Local OVP Control jumper J65 and the Remote OVP Control jumper J103, both on the RS-232 interface PCB. The default jumper settings allow control of OVP to depend on the operating state of the power supply. By physically changing the jumper settings, you can isolate the location of OVP control to software control only or front panel control only. Table 2.12, "OVP Control Mode Selection" shows a table of jumper settings and OVP programming selection. Refer to "Basic Setup Procedure" on page 23 for the positions of the jumpers on the RS-232 PCB.

Table 2.12 OVP Control Mode Selection

PCB Jumper J65 Position	PCB Jumper J103 Position	OVP Programming Selection
Closed (default)	Closed (default)	Software or Front Panel OVP control (dependent on the power supply operating state)
Closed	Open	Software OVP control only
Open	Closed	Front Panel OVP control only
Open	Open	Front Panel OVP control only

TTL Shutdown

You can use the Shutdown function to disable or enable the supply's output. Disabling the supply using TTL shutdown allows you to make adjustments to the load or to the power supply without shutting down the power supply. With the RS-232 interface installed, TTL shutdown is activated by a TTL signal to Pin 1 of the J7 connector on the interface subplate. The shutdown user line uses a 0-5Vdc TTL input with a high signal range of 2.2-5.0Vdc. The current range of the shutdown line is 1-10mA. See Figure 2.6, "J7 User Signal Connector Circuit Block Diagram" on page 35 for a schematic of the J7 connector containing the shutdown user line.

You can select the logic level of the TTL input by changing the J93 connector on the RS-232 PCB. Table 2.13 shows the TTL signal levels for the J93 jumper settings. See Figure 2.2-3 for the location of the J93 jumper on the printed circuit board.

Table 2.13 Switch Settings for TTL Shutdown Circuit Logic

PCB Jumper J93 Position	TTL Signal Level	Supply Output Condition
Pin 2 to Pin 3 (default)	HIGH	OFF
	LOW	ON
Pin 1 to Pin 2	HIGH	ON
	LOW	OFF

Installation and Configuration

User Signals

User Signals

Connector J7 User Signals

Auxiliary connector J7, located on the RS-232 interface rear panel, provides several signals to increase your operating control of the supply. These signals are dependent on the operator's design and uses. The operation of the J7 signal requires that you provide external Vcc and ground. Use a standard 8-position telephone jack and data cable to connect to J7. To locate the connector, refer to the RS-232 interface subplate drawing in Figure 2.2, on page 21. See Figure 2.5 for pin descriptions. The J7 outputs can sink a current of 5mA each. Figure 2.6, on page 35 shows the portion of the option board schematic which contains the J7 connector. Use the schematic as a reference when making input or output connections.

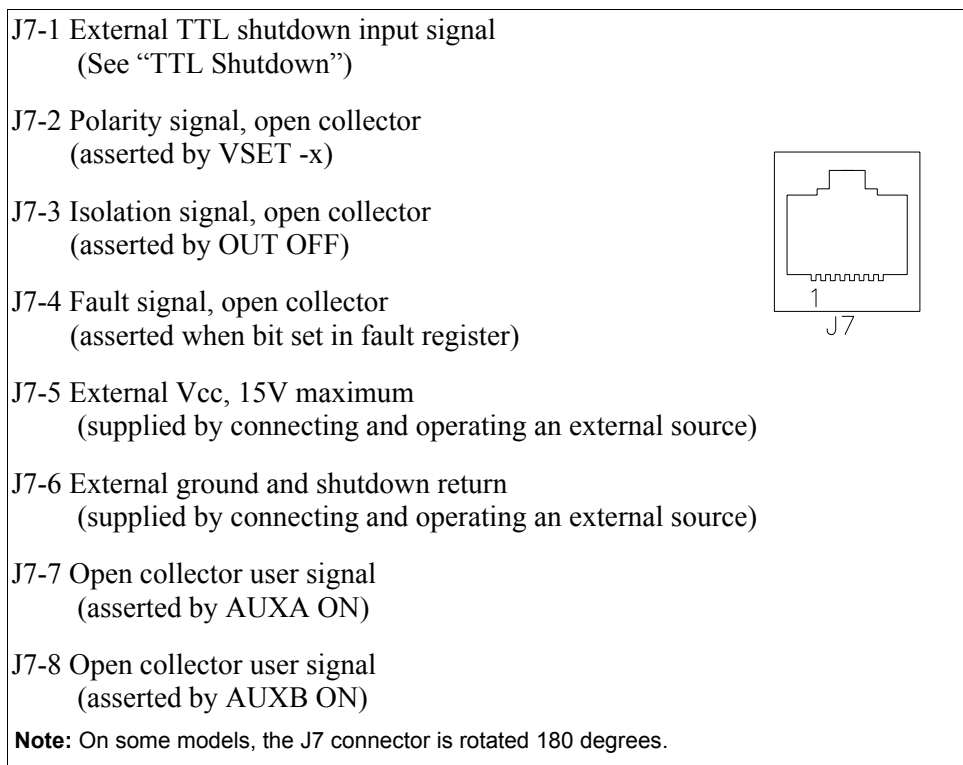

Figure 2.5 User Signals J7 Connector

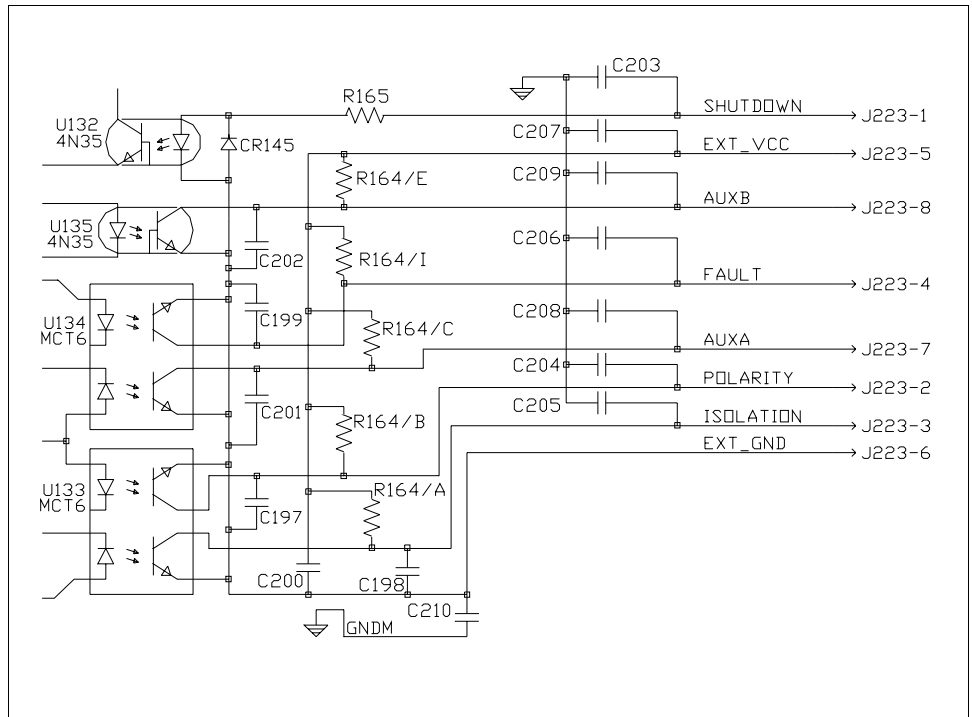

Figure 2.6 J7 User Signal Connector Circuit Block Diagram

J7 Cable Connection

Use a standard 8-position telephone jack and data cable to connect to J7. Add a ferrite block to reduce radiated emission. The one inch square ferrite block with built-in housing clip is packaged and shipped with the power supply interface card.

To install the ferrite block:

1. Position the block no more than 5 cm (2 in.) from the power supply end of the J7 user cable.
2. Open the ferrite block housing.
3. Loop the cable through the ferrite block. See Figure 2.7, “J7 User Cable with Ferrite Block” on page 36.
4. Close the housing clip.

The ferrite block ensures that the power supply system meets radiated emission requirement 89/336/EEC for CE mark approval. See the power supply's operating manual for noise specifications.

Installation and Configuration

User Signals

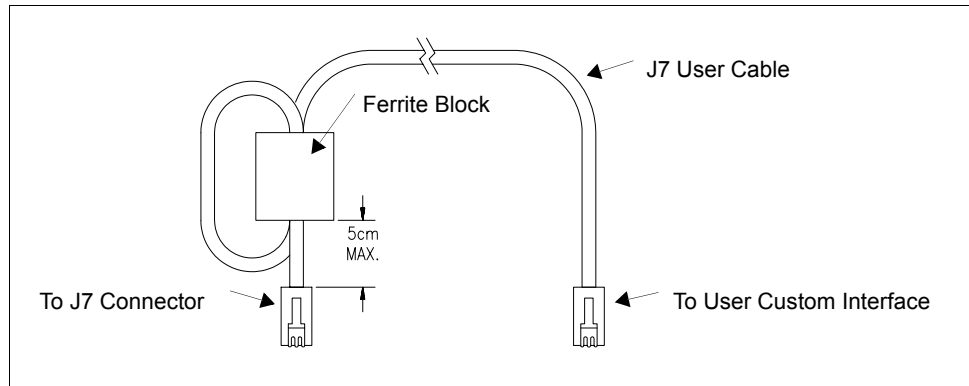

Figure 2.7 J7 User Cable with Ferrite Block

Section 3. Operation

Introduction

This section covers RS-232 interface programming, including an extensive set of device-dependent commands, and providing error codes, and status and fault register information.

RS-232 Operation

The RS-232 interface card lets you send and receive data between your power supply and computer, relying on bit serial communication. You can use the computer controller to issue commands to the power supply for programming, queries, calibration, or status. The power supply responds to the complete command set of device dependent software commands shown in “Command Reference” on page 44.

Command Syntax

Manual Conventions The manual uses these conventions when displaying command information. These characters are not part of the command but are used to denote parameters used with the command.

< > (angle brackets)	Angle brackets enclose a parameter. Do not include the angle brackets in the command line you send to the computer.
/ (slash)	Separates two alternative parameters. When a slash separates two parameters, you can use either parameter to achieve the same result. Example: <1/ON> Entering 1 or ON will achieve the same result.
COMPUTER ENTRY	Words typed on the computer are shown in Arial text, full capitals.

Operation

Command Syntax

Command Format and Parameters

The device-dependent language for the RS-232 Interface consists of commands and parameters. A command is a one word code which either gives instructions to the interface or asks for information from the interface. A command may be followed by one or more parameters, a short code that changes the state of the power supply or the state of the bit register. Table 3.1, "Command Parameters" lists the parameters that affect the command set.

Format:

COMMAND or
COMMAND <parameter> or
COMMAND <parameter>,<parameter>

- You can enter commands in upper or lower case lettering.

Example: MASK FOLD = mask fold

- Do not further abbreviate command names or parameters.

Example: MASK FOLD ≠ MK FOLD
MASK FOLD ≠ MASK FD

- Use a space between the command and the first parameter. Any number of consecutive spaces is treated as one space. Numeric data may contain leading spaces. Embedded spaces between digits or between a digit and a decimal point are not accepted.

Example: MASK FOLD = MASK FOLD
VOUT 3.4 = VOUT 3.4
VOUT 3.4 ≠ VOUT 3.4

- Use commas between parameters in those commands with more than one parameter, and between mnemonic parameters as in the MASK and UNMASK commands. Only one comma is allowed and it may be preceded or followed by any number of spaces.

Example: MASK CV, OV, FOLD

Table 3.1 Command Parameters

Parameter	Description	Form
<current>, <lhi>, <llo>	The current in amps or milliamps. If no unit is given, the default unit is amps.	<float> <float>A <float>mA
<time>	The time in seconds or milliseconds. If no unit is given, the default unit is seconds.	<float> <float>s <float>ms
<voltage>, <vlo>, <vhi>	The voltage in volts or millivolts. If no unit is given, the default unit is volts.	<float> <float>V <float>mV
<mnemonics>	A combination of CV, CC, OV, OT, SD, FOLD, ERR, PON, REM, ACF, OPF, and SNSP. See MASK and UNMASK commands in the command reference for use of the ALL and NONE parameters.	See registers on page 51.
<state>	The state of a binary condition.	<1/ON, 0/OFF>

Floating Point Number <float> Variables sent with command parameters are floating point numbers. Table 3.2 defines the structure of floating point numbers for use with the software commands.

Table 3.2 Floating Point Numbers

Floating Number Definition	Example
The floating point number has four significant figures. It can be of either sign, positive or negative.	1.234 -1.234 +1.234
A floating point number can have one decimal point.	0.123 1.2 123.4
Scientific Notation Use E or e after the number for a base ten exponent. An integer of either sign must follow an exponent.	123.0E-1 1.2E-1 10.00E+1

Command Strings

If you send more than one command line, separate the commands with a semicolon. The semicolon may be preceded or followed by spaces.

Example:

```
ISET 2.0A; VSET 5V
ISET 2.0A; VSET 5V
```

Operation

Command Syntax

Command Terminators Terminators indicate the end of a command string and tell the power supply to execute the command. The termination character is LF (Line Feed).

Format:

COMMAND <parameter>; COMMAND <parameter>, <parameter><LF>

Most computer controllers automatically send LF with output statements.

Order You may send commands in any order, keeping in mind that only those commands received after a HOLD and before a TRG (trigger) will be released by the TRG command. In addition, only these commands received after a supply disable and before a RST (reset) or OUT ON command will be released by the RST command or the OUT command. Commands are executed in the order they are received.

Command Summary

Use these commands to control the operation of the supply. They are listed here in order of function such as PROGRAMMING, QUERY, CALIBRATION, and STATUS commands. See “Command Reference” on page 44 for more detailed information about each command and its use.

Table 3.3 Programming Commands

Command	Description
AUXA	Selects the state of the AUXA output signal on the J7-7 connector.
AUXB	Selects the state of the AUXB output signal on the J7-8 connector.
CLR	Initializes the power supply to its Power ON (PON) state.
DLY	Sets a programmable time delay which is executed by the supply before reporting fault conditions after a new output voltage or current is specified.
GTL	Sends the supply to local mode.
FOLD	Sets foldback mode for the supply.
HOLD	Enables or disables voltage/current setting hold mode for the supply.
IMAX	Sets an upper soft limit on the programmed output current for the supply.
ISSET	Sets the output current of the supply in amps (default) or in milliamps.
LLO	Local Lockout. Disables the front panel LOCAL button.
OUT	Enables or disables voltage/current output for the supply.
OVSET	Sets the over voltage protection trip point for the supply in volts (default) or in millivolts.
REN	Sets remote mode or local mode.
RST	Resets the supply to the present voltage and current settings if the output is disabled by OVP or foldback protection.
TRG	Implements programmed voltage and current settings which had been in hold mode.
VMAX	Sets an upper soft limit on the supply's programmed output voltage.
VSET	Sets the output voltage of the power supply in volts (default) or in millivolts.

Operation

Command Summary

Table 3.4 Query Commands

Command	Description
AUXA?	Asks for the state of the set value for the AUXA command
AUXB?	Asks for the state of the set value for the AUXB command
CMODE?	Asks for the power supply's calibration mode status.
DLY?	Asks for the programmable time delay setting before the supply reports fault conditions.
ERR?	Asks for the most recent remote programming error which occurred in the supply since the last time the error query command (ERR?) was used.
FOLD?	Asks for the supply's present foldback setting.
HOLD?	Asks for the present hold mode setting.
ID?	Asks for the power supply's model name and master EPROM version.
IMAX?	Asks for the supply's soft current limit setting.
IOUT?	Measures the supply's actual current output.
ISET?	Asks for the supply's present output current limit setting.
OUT?	Asks for the present enabled/disabled status of the supply's output.
OVSET?	Asks for the supply's present over voltage protection limit.
REN?	Asks for the state of remote enable.
ROM?	Asks for the version number of the master and slave EPROMs on the interface PCB.
VMAX?	Asks for the supply's soft voltage limit setting.
VOUT?	Measures the supply's actual voltage output.
VSET?	Asks for the supply's present output voltage setting.

Table 3.5 Calibration Commands

Command	Description
CMODE	Places the supply into calibration mode.
IDATA	Calculates the slope and intercept for current programming.
IHI	Sets the current output to the high calibration point.
ILO	Sets the current output to the low calibration point.
IRDAT	Calculates the slope and intercept for current readback.
IRHI	Sets the current output to the high readback point.
IRLO	Sets the current output to the low readback point.
OVCAL	Calibrates the over voltage protection (OVP).
VDATA	Calculates the slope and intercept for voltage programming.
VHI	Sets the voltage output to the high calibration point.
VLO	Sets the voltage output to the low calibration point.
VRDAT	Calculates the slope and intercept for voltage readback.
VRHI	Sets the voltage output to the high readback point.
VRLO	Sets the voltage output to the low readback point.

Table 3.6 Status Commands

Command	Description
ASTS?	Asks for the supply's accumulated status register.
FAULT?	Asks for the supply's fault register for the status preset operating conditions.
MASK	Prevents the supply's previously unmasked operating conditions from setting bits in the fault register.
STS?	Asks for the supply's present status register.
UNMASK	Enables you to select those supply's operating conditions that you are most interested in monitoring for fault occurrence.
UNMASK?	Asks for the supply's fault conditions which are currently enabled (unmasked).

Command Reference

Table 3.7 Command Reference

Command	Description
ASTS?	Asks for the supply's accumulated status register. The accumulated status register stores any bit that was entered in the status register since the accumulated status query command (ASTS?) was last used, regardless of whether the condition still exists. The accumulated status register has the same bits, weights, and conditions as the status register. A bit in the accumulated status register will be set at 1 if the corresponding bit in the status register has been 1 (TRUE) at any time since the register was last read. See "Accumulated Status, Status, and Fault Registers" on page 51. The ASTS? query clears the status register. Response: ASTS <status mask> where status mask is the decimal equivalent of the total bit weights for the operating conditions as listed in the status register.
AUXA <1/ON>,<0/OFF>	Controls the AUXA output signal level at rear panel connector J7-7. Active low. Initial value: AUXA 0
AUXA?	Asks for the present set value of the AUXA output signal. Response: AUXA 0 (OFF) AUXA 1 (ON)
AUXB <1/ON>,<0/OFF>	Controls the AUXB output signal level at rear panel connector J7-8. Active low. Initial value: AUXB 0
AUXB?	Asks for the present set value of the AUXB output signal. Response: AUXB 0 (OFF) AUXB 1 (ON)
CLR	Initializes the power supply to its power ON condition. If issued while in local mode, CLR will force power supply settings to register default values as in but these default settings will not come into effect until the power supply is switched to remote mode operation. The CLR commands will clear faults from the fault register. CLR will not reset CMODE.
CMODE <1/ON>,<0/OFF>	CMODE ON places the power supply into calibration mode for processing calibration commands. Initial value: CMODE OFF or CMODE 0
CMODE?	Asks for the power supply's calibration mode status. Response: CMODE 0 (disabled) CMODE 1 (enabled)

Command	Description
DLY <seconds>	<p>Sets a programmable time delay employed by the supply before reporting fault conditions. The power supply uses the time delay after receiving a new output voltage or current setting via VSET or ISET, or after receiving RST, TRG, or OUT ON commands. During the time delay, the power supply disables CV, CC, and FOLD conditions from generating faults, preventing possible nuisance foldback if the supply momentarily switches modes while changing an output setting.</p> <p>Range: 0 to 32 seconds, with 32ms resolution Initial value: 0.5 second</p>
DLY?	<p>Asks for the setting of the programmable time delay before the supply reports fault conditions.</p> <p>Response: DLY <seconds></p>
ERR?	<p>Asks for the most recent remote programming error. When the power supply detects a programming error, it lights the ERR LED and sets the ERR bit in the accumulated status and fault registers. If the error bit has been masked using the MASK command, then the ERR bit in the registers will not set. Once an error is detected, the remaining portion of the command line is discarded. An error query clears the ERR bit in the accumulated status register. See “Error Codes” on page 53.</p> <p>Response: ERR <error number> Example: ERR 0 (if no error)</p>
FAULT?	<p>Asks for the state of the fault register. A bit is set in the fault register when a fault arises for that condition. Lists the conditions which activate a fault bit. You can use the MASK command to disable bits from being set in the fault register.</p> <p>When a bit is set in the fault register it also asserts a signal on the J7-4 user signal line. You can tie the J7-4 fault line signal to the power supply's own External Shutdown user line, J7-1, so that the shutdown signal goes low (active) in the case of a user-defined fault.</p> <p>The FAULT? query clears bits in the supply's fault register and fault line.</p> <p>Response: FAULT <fault mask> where fault mask is the decimal equivalent of the total bit weights for the operating conditions as listed in the fault register. See “Accumulated Status, Status, and Fault Registers” on page 51.</p>
FOLD <2/CC>, <1/CV>, <0/OFF>	<p>Sets foldback mode for the supply. Foldback protection disables the power supply output when the output enters the fold condition. Reset with the RST command.</p> <p>Example: Specify FOLD 1 or FOLD CV (Constant Voltage) when you want the supply to operate in Constant Current mode and have foldback protection disable the output if the supply switches to Constant Voltage mode.</p> <p>Initial value: FOLD 0/OFF</p>

Operation

Command Reference

Command	Description
FOLD?	Asks for the supply's present foldback setting. Response: FOLD <mode> where mode is: 0 (OFF) or 1 (CV or Constant Voltage mode) or 2 (CC or Constant Current mode)
GTL	Go to local. Returns the power supply to local control. See LLO (Local Lockout). See also "Remote/Local Operation" on page 27.
HOLD <1/ON>,<0/OFF>	Enables or disables voltage/current setting hold mode for the supply. When HOLD ON is specified, hold mode is enabled so that all voltage and current settings which would normally be implemented by the supply are held until a TRG (trigger) command is received. This feature allows you to synchronize the operation of several supplies. Initial value: HOLD OFF or HOLD 0
HOLD?	Asks for the present hold mode setting. Response: HOLD 0 (OFF or disabled) or HOLD 1 (ON or enabled)
ID?	Asks for the power supply model and the master EPROM version. Response: ID <model name><version>
IDATA <llo>,<lhi>	Calculates and records the slope and offset for programmed current using ILO and IHI data. Set CMODE ON before using this command. See also the calibration procedures in Section 4. <llo> and <lhi> are in <current> format.
IHI	In response to this command, the power supply sends a programmed current value to the output terminal. This value is at the high end of the power supply's current range and is read by an external device connected as part of the calibration procedure. Refer to this value as IHI and record it to use as input with the IDATA command. Set CMODE ON before using this command. See also the calibration procedures in Section 4.
ILO	In response to this command, the power supply sends a programmed current value to the output terminal. This value is at the low end of the power supply's current range and is read by an external device connected as part of the calibration procedure. Refer to this value as ILO and record it to use as input with the IDATA command. Set CMODE ON before using this command. See also the calibration procedures in Section 4 .
IMAX <current>	Sets an upper soft limit on the supply's programmed output current. If the soft limit is exceeded, or if the soft limit value is lower than the present output current setting, the supply will ignore the command, turn on the ERR LED, and set the ERR bit in the bit registers. Range: 0 to model maximum output current (IMAX) Initial value: model IMAX
IMAX?	Asks for the supply's soft current limit setting. Response: IMAX <current>

Command	Description
IOUT?	Measures the supply's actual current output using the built-in current readback circuitry. Response: IOUT <current>
IRDAT <llo>,<lhi>	Calculates and records the slope and offset for readback voltage using IRLO and IRHI data. Set CMODE ON before using this command. See also the calibration procedures in Section 4. <llo> and <lhi> are in <current> format.
IRHI	The power supply outputs a current value to an external device connected as part of the calibration procedure and records a current readback value internally. These values are at the high end of the programmed current range. Refer to the output value as IRHI and record it to use as input with the IRDAT command. Set CMODE ON before using this command. See also the calibration procedures in Section 4.
IRLO	The power supply outputs a current value to an external device connected as part of the calibration procedure and records a current readback value internally. These values are at the low end of the programmed current range. Refer to the output value as IRLO and record it to use as input with the IRDAT command. Set CMODE ON before using this command. See also the calibration procedures in Section 4.
ISET <current>	Sets the power supply's output current in amps (default) or in milliamps. This programmed current is the actual output in CC mode or the current limit in CV mode. Range: 0 to model maximum output current (IMAX) Initial value: 0 amps
ISET?	Asks for the supply's present output current setting. Does not apply to current settings which are being held. See HOLD command. Response: ISET <current>
LLO	Disables the front panel LOCAL switch. When LLO is in effect you can only return to local mode using the GTL command. You can remove the local lockout with the REN command. See also "Remote/Local Operation" on page 27.
MASK <mnemonics>	Disables the supply's previously unmasked operating conditions from setting bits in the fault and status registers. See "Accumulated Status, Status, and Fault Registers" on page 51. Mnemonics are separated from each other by commas and may be sent in any order. Mnemonics: CV, CC, OV, OT, SD, FOLD, ERR, PON, REM, ACF, OPF, SNSP Note: UNMASK NONE = MASK ALL (Initial value) MASK NONE = UNMASK ALL

Operation

Command Reference

Command	Description
OUT <1/ON>,<0/OFF>	<p>Enables or disables the supply's voltage/current output. The supply will continue to accept new commands while the output is disabled but these will not be implemented until OUT ON or OUT 1 is received. OUT ON is the default setting. When you start the supply in remote mode, the output is enabled.</p> <p>OUT OFF (or OUT 0) also sets the isolation signal on the rear panel J7 connector, line 3. You can use the to trip external relays to isolate the power supply from the load.</p> <p>Initial value: OUT ON (or OUT 1) for output enabled</p>
OUT?	<p>Asks for the present enabled/disabled status of the supply's output voltage/current.</p> <p>Response: OUT 1 output enabled or OUT 0 output disabled</p>
OVCAL	<p>Causes the master controller to perform automatic calibration of the supply's over voltage protection circuitry. Set CMODE ON before using this command. Ensure jumper J65 on the RS-232 Interface PCB is connected for remote operation.</p>
OVSET <voltage>	<p>Sets the supply's over voltage protection trip point in volts (default) or in millivolts. If the trip point is exceeded, or if the trip point value is lower than the present output voltage setting, the supply will ignore the command, turn on the ERR LED, and set the ERR bit in the accumulated status register. Reset with the RST command.</p> <p>Range: 0 to 110% of model maximum output voltage (VMAX)</p> <p>Initial value: 110% of model VMAX</p>
OVSET?	<p>Asks for the supply's present over voltage protection limit.</p> <p>Response: OVSET <voltage></p>
REN <1/ON>,<0/OFF>	<p>Remote Enable. When set to REN 0, the power supply is in local mode. If a command is sent from the computer, the power supply does not respond but remains in local mode. When set to REN 1, the power supply will enter remote mode if a command is sent from the computer. See also "Remote/Local Operation" on page 27.</p>
REN?	<p>Asks for the state of the remote enable. See REN command.</p> <p>Response: REN <state></p>
ROM?	<p>Asks for the version number of the master and slave EPROMs located on the interface PCB.</p> <p>Response: ROM M:<version> S:<version></p>
RST	<p>Resets the supply to present voltage and current settings if the output is disabled by over voltage or foldback protection. Output values may be changed via VSET, ISET, and OVSET while the unit is disabled, but those values will not take effect until RST is applied.</p>

Command	Description
STS?	<p>Asks for the supply's present status register. Status conditions are stored in the status register. Each bit represents a separate condition. When the condition is true, the corresponding bit is 1 (true). Bits remain set in the status register as long as the condition is true. See "Accumulated Status, Status, and Fault Registers" on page 51.</p> <p>Response: STS <status mask> where status mask is the decimal equivalent of the total bit weights for the operating conditions as listed in the status register.</p>
TRG	<p>Implements programmed voltage and current settings which had been in hold mode. The supply operates with previous values until the TRG (trigger) command is sent.</p>
UNMASK <mnemonics>	<p>Enables you to select the supply operating conditions that you are most interested in monitoring for fault occurrence. Mnemonics describing the conditions are separated from each other by commas, and may be sent in any order.</p> <p>Specifying one or more mnemonics which describe the conditions (or the decimal equivalent of their total bit weight) enables the selected conditions to set bits in the supply's fault and status registers during operation. A bit is set in the fault register when the corresponding bit in the status register changes from 0 to 1 and the corresponding bit in the mask register is 1. See "Accumulated Status, Status, and Fault Registers" on page 51.</p> <p>Mnemonics: CV, CC, OV, OT, SD, FOLD, ERR, PON, REM, ACF, OPF, SNSP, ALL, NONE</p> <p>Initial value: UNMASK NONE</p>
UNMASK?	<p>Asks for the supply's fault conditions which are currently enabled (unmasked).</p> <p>Response: UNMASK <fault mask> where fault mask is the decimal equivalent of the total bit weights for the operating conditions as listed in the status and fault registers See "Accumulated Status, Status, and Fault Registers" on page 51.</p>
VDATA <Vlo>,<Vhi>	<p>Calculates and records the slope and offset for programmed voltage using VLO and VHI data. Set CMODE ON before using this command. See also the calibration procedures in Section 4.</p> <p><Vlo> and <Vhi> are in <voltage> format.</p>
VHI	<p>In response to this command, the power supply sends a programmed voltage value to the output terminal. This value is at the high end of the power supply's voltage range and is read by an external device connected as part of the calibration procedure. Refer to this value as VHI and record it to use as input with the VDATA command. Set CMODE ON before using this command. See also the calibration procedures in Section 4.</p>

Operation

Command Reference

Command	Description
VLO	In response to this command, the power supply sends a programmed voltage value to the output terminal. This value is at the low end of the power supply's voltage range and is read by an external voltmeter connected as part of the calibration procedure. Refer to this value as VLO and record it to use as input with the VDATA command. Set CMODE ON before using this command. See also the calibration procedures in Section 4.
VMAX <voltage>	Sets an upper soft limit on the supply's programmed output voltage. If the soft limit is exceeded, or if the soft limit value is lower than the present output voltage setting, the supply will ignore the command, turn on the ERR LED, and set the ERR bit in the accumulated status register. Range: 0 to model maximum output voltage (VMAX) Initial value: model VMAX
VMAX?	Asks for the supply's soft voltage limit setting. Response: VMAX <voltage>
VOUT?	Measures the supply's actual voltage output using the built-in voltage readback circuitry. Response: VOUT <voltage>
VRDAT <Vlo>,<Vhi>	Calculates and records the slope and offset for readback voltage using VRLO and VRHI data. Set CMODE ON before using this command. See also the calibration procedures in Section 4 . <Vlo> and <Vhi> are in <voltage> format.
VRHI	The power supply outputs a voltage value to an external voltmeter connected as part of the calibration procedure and records a voltage readback value internally. These values are at the high end of the programmed voltage range. Refer to the output value as VRHI and record it to use as input with the VRDAT command. Set CMODE ON before using this command. See also the calibration procedures in Section 4.
VRLO	The power supply outputs a voltage value to an external voltmeter connected as part of the calibration procedure and records a voltage readback value internally. These values are at the low end of the programmed voltage range. Refer to the output value as VRLO and record it to use as input with the VRDAT command. Set CMODE ON before using this command. See also the calibration procedures in Section 4.
VSET <voltage> or VSET <-voltage>	Sets the power supply's output voltage in volts (default) or in millivolts. This programmed voltage is the actual output in CV (constant voltage) mode or the voltage limit in CC (constant current) mode. If you enter a negative voltage value, the power supply will assert a signal on the J7-4 user signal line. You can use the user signal to trip external relays to switch the output polarity. Range: 0 to model maximum output voltage (VMAX) Initial value: 0 volts
VSET?	Asks for the power supply's present output voltage setting. Does not apply to voltage settings which are being held. See HOLD command. Response: VSET <voltage>

Accumulated Status, Status, and Fault Registers

The RS-232 option card uses three separate registers which are always active. They are the accumulated status, status, and fault registers. You can use the status commands shown in Table 3.6, “Status Commands” to activate the registers. The bit register has twelve conditions, each assigned a bit weight. When querying a register, the controller returns a response which is the sum of the weights of all relevant conditions.

Example:

ASTS?	Query the Accumulated Status register.
ASTS 771	Controller response.
$771 = 512 + 256 + 2 + 1 = \text{PON} + \text{REM} + \text{CC} + \text{CV}$	

The accumulated status register shows that PON, REM, CC and CV have all been active since the last accumulated status register query.

Table 3.8 shows the mnemonics and bit weights which correspond to each register condition. You can select conditions you want to monitor in the fault and status register by using the MASK and UNMASK commands.

Operation

Accumulated Status, Status, and Fault Registers

Table 3.8 Accumulated Status, Status, and Fault Registers

Condition	Mnemonic	Bit Position	Bit Weight
Constant voltage operation	CV	0	1
Constant current operation	CC	1	2
Not used	–	2	4
Overvoltage protection tripped	OV	3	8
Over temperature protection tripped	OT	4	16
Supply external shutdown active (J7-1)	SD	5	32
Foldback mode operation	FOLD	6	64
Remote programming error	ERR	7	128
Power ON (accumulated status, status registers only)	PON	8	256
Remote mode (accumulated status, status registers only)	REM	9	512
AC fail condition	ACF	10	1024
Output fail condition	OPF	11	2048
Sense protection tripped	SNSP	12	4096

Notes:

1. All mnemonics can be masked or unmasked.
2. The error (ERR) bit is reset in the accumulated status, status, and serial poll registers with an error query (ERR?).
3. The accumulated status register is cleared with an accumulated status query (ASTS?).
4. A fault is cleared with a fault query (FAULT?).

Error Codes

If the ERR flag in the accumulated status or fault registers has been activated, an ERR? query will return an error number which corresponds to an event described in the following table. The ERR? query will also clear the ERR bit in the register.

Table 3.9 Error Codes

ERROR #	ERROR IDENTIFICATION	EXPLANATION
0	No Errors	
4	Unrecognized Character	Received a character such as @, *, \$.
	Improper Number	Received a numeric character but the characters were not a proper number. Example: VSET,±10.3
	Unrecognized String	Received an invalid command.
	Syntax Error	Received an incorrectly placed word, number, separator, or terminator. Example: OFF SRQ, VOUT 6, MASK, ERR
5	Number Out of Range	Specified a value for the command which was outside of the allowed range.
6	Attempt to Exceed Soft Limits	Attempted to program a voltage or current greater than the soft limit. Example: VMAX 500; VSET 550 LF
7	Improper Soft Limit	Attempted to program a soft limit less than the output value.
8	Data Requested without a Query Being Sent	The controller requested data from the power supply without first sending a query command.
9	OVP Set Below Output	Sent an OVSET command with a trip value lower than the output voltage.
10	Slave Processor Not Responding	The interface PCB slave processor did not respond.
12	Illegal Calibration	Attempted calibration when the supply was not in calibration mode. See CMODE command.

Troubleshooting



WARNING

Exercise caution when using and servicing power supplies. High energy levels can be stored at the output voltage terminals on all power supplies in normal operation. In addition, potentially lethal voltages exist in the power circuit and the output connector of power supplies which are rated at 40V and over. Filter capacitors store potentially dangerous energy for some time after power is removed.

Diagnostic LEDs

This section describes the diagnostic LEDs found on the RS-232 interface.

Computer Operating Properly (COP) LEDs The RS-232 interface provides three diagnostic LEDs, located at CR167, CR166, and CR89 on its PCB. Refer to Figure 2.3, ‘RS-232 Interface PCB’ on page 22, for their locations. At present, these LEDs turn on to signal COP events for the interface's microprocessors. Issue a RST (reset) command to turn off the diagnostic LEDs.

The green COP LED at circuit designation CR167 indicates that the RS-232 interface microprocessor successfully recovered from a timeout error due to a communications bus error. The event is transparent to the RS-232 communications line continues to function normally.

The red COP LED at CR166 indicates that a transparent restart caused by noise in the master processor circuitry has occurred.

The red COP LED at CR89 indicates that a transparent restart caused by noise in the slave processor circuitry has occurred.

Section 4. Calibration

Introduction



WARNING

Exercise caution when using and servicing power supplies. High energy levels can be stored at the output voltage terminals on all power supplies in normal operation. In addition, potentially lethal voltages exist in the power circuit and the output connector of power supplies which are rated at 40V and over. Filter capacitors store potentially dangerous energy for some time after power is removed.

You can calibrate the RS-232 interface by adjusting the signal levels on the interface card so that they correspond to the expected signal levels on the power supply's main assembly. You may need to recalibrate the interface if you replace parts either on the interface board or on the main power supply board, or if the unit falls out of specification due to component aging drifts.

You can calibrate the RS-232 Interface for:

- Voltage program
- Voltage readback
- Current program
- Current readback
- Overvoltage protection

The following equipment will be required to accurately calibrate your unit:

- Digital Voltmeter, 5 1/2 digit, 0.1% accuracy or better, with test leads
- Current sensing shunt resistor, rated for 150% of maximum output current, 0.25% accuracy or better
- Connection wires rated for the unit's maximum output current and voltage
- An RS-232 equipped computer to send the calibration commands to the unit

Calibrate the unit according to the following procedures, referring to “Command Reference” for more information about the calibration commands used.

The calibration procedures in this section are designed to be performed at an ambient temperature of $25^{\circ}\text{C} \pm 5^{\circ}\text{C}$.

Calibration

Voltage Mode Calibration

Voltage Mode Calibration

Voltage Calibration Setup

1. Disconnect the load from the power supply which is to be calibrated.
2. Connect a voltmeter across the power supply's output terminals.

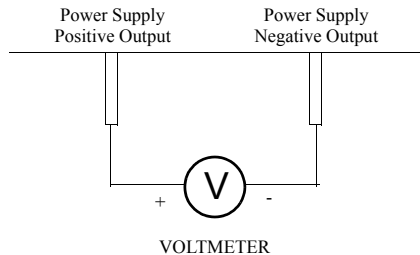

Figure 4.1 Voltage Calibration Setup

Voltage Program Calibration Procedure

1. Set the power supply for calibration as in Figure 4.1.
2. Activate calibration mode by sending command `CMODE ON` or `CMODE 1` to the power supply.
3. Send command `VLO; ILO` to the power supply. Measure and record the output shown on the external voltmeter.
4. Send command `VHI; IHI` to the supply. Measure and record the output voltage as shown on the external voltmeter.
5. Send the command `VDATA <vlo>, <vhi>` where `<vlo>` and `<vhi>` are the values read from the voltmeter when the `VLO` and `VHI` commands were sent. When the power supply is calibrated, the low to high voltage program calibration values are stored as constants.
6. Program the supply at various levels using the `VSET` command to confirm that the calibration was successful and that linearity is observed. See the voltage program accuracy specification in Section 1.
7. Turn off calibration mode by sending the command `CMODE OFF` or `CMODE 0` to the power supply.

**Voltage
Readback
Calibration
Procedure**

1. Set the power supply for calibration as in Figure 4.1.
2. Activate calibration mode by sending command CMODE ON or CMODE 1 to the power supply.
3. Send command VRLO; IRLO to the power supply. Wait for the supply to settle. Measure and record the output shown on the external voltmeter. Send VRLO again.
4. Send VRHI; IRHI to the supply. Wait for the supply to settle. Measure and record the output voltage shown on the external voltmeter. Send VRHI again.
5. Send the command VRDAT <vlo>,<vhi> where <vlo> and <vhi> are the values read from the voltmeter after the VRLO and VRHI commands were sent. The processor calculates the offset value required to calibrate the power supply. When the power supply is calibrated, the low to high voltage readback calibration values (offsets) are stored as constants.
6. Use commands VSET and VOUT? commands to confirm that the calibration was successful and that linearity is observed. Refer to the voltage readback accuracy specification in Section 1.
7. Turn off calibration mode by sending the command CMODE OFF or CMODE 0 to the power supply.

Calibration

Current Mode Calibration

Current Mode Calibration

Current Calibration Setup

1. Disconnect the load from the power supply to be calibrated.
2. Connect a shunt across the supply's output terminals.
3. Connect a voltmeter across the shunt.

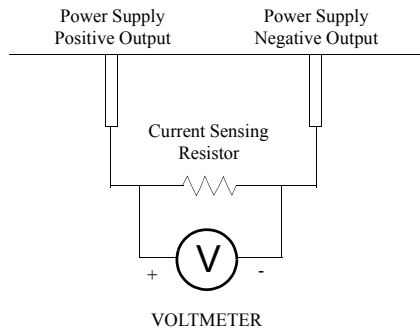

Figure 4.2 Current Calibration Setup

Current Program Calibration Procedure

1. Connect the shunt and voltmeter to the power supply as shown in Figure 4.2.
2. Activate calibration mode by sending command CMODE ON or CMODE 1 to the power supply.
3. Send command ILO; VLO to the power supply. Measure and record the output shown on the external voltmeter.
4. Send command IHI; VHI to the supply. Measure and record the output voltage shown on the external voltmeter.
5. Calculate ILO and IHI from the voltages read from the external voltmeter and the shunt resistance. $I = V/R$.
6. Send the command IDATA <ilo>, <ihi> to the power supply. <ilo> and <ihi> are the current values obtained from sending the ILO and IHI commands to the power supply. When the power supply is calibrated, the low to high current program calibration values are stored as constants.
7. Program the supply at various levels using the ISET command to confirm that the calibration was successful and that linearity is observed. Refer to the current program accuracy specification in Section 1.
8. Turn off calibration mode by sending the command CMODE OFF or CMODE 0 to the power supply.

**Current
Readback
Calibration
Procedure**

1. Connect the current shunt and voltmeter to the power supply as shown in Figure 4.2.
2. Activate calibration mode by sending command CMODE ON or CMODE 1 to the power supply.
3. Send command IRLO; VRLO to the power supply. Wait for the supply to settle. Measure and record the output voltage shown on the external voltmeter. Send IRLO again.
4. Send command IRHI; VRHI to the supply. Wait for the supply to settle. Measure and record the output voltage shown on the external voltmeter. Send IRHI again.
5. Calculate IRLO and IRHI from the voltages taken from the external voltmeter and the shunt resistance. $I=V/R$.
6. Send the command IRDAT <ilo>,<ihi> to the power supply. <ilo> and <ihi> are the current values obtained from sending the IRLO and IRHI commands to the power supply. When the power supply is calibrated, the low to high current readback calibration values are stored as constants.
7. Program the supply at various levels using the ISET command to confirm that the calibration was successful and that linearity is observed. Refer to the current readback accuracy specification in Section 1.
8. Turn off calibration mode by sending the command CMODE OFF or CMODE 0 to the power supply.

Calibration

Over Voltage Protection (OVP) Calibration

Over Voltage Protection (OVP) Calibration

We recommend that you perform OVP calibration every six months. Connecting a digital voltmeter as in “Voltage Calibration Setup” is optional.

1. Disconnect all loads from the power supply.
2. Ensure that jumper J65 on the interface PCB is CLOSED to enable remote OVP calibration (Jumper J65 is closed at the factory). See Figure 2.3 RS-232 Interface PCB, p. 22 for the location on the PCB of jumper J65.
3. Activate calibration mode by sending command CMODE ON or CMODE 1 to the power supply.
4. Send the command OVCAL to the power supply. The ADDR LED will light during OVP calibration. Calibration is complete when the ADDR LED turns off. This may take a few minutes.
5. Use the OVSET, OVSET?, and VSET commands to trip the OVP level, confirming that the calibration was successful. When you trip the OVP level, the red OVP LED will light and the voltage will drop to zero. Send the command RST to clear the OVP condition. Refer to the OVP program accuracy specification in Section 1.
6. Turn off calibration mode by sending the command CMODE OFF or CMODE 0 to the power supply.

Xantrex Technology Inc.

8999 Nelson Way
Burnaby, British Columbia
Canada V5A 4B5

604 422 8595 Tel
604 421 3056 Fax
800 667 8422 Toll Free North America

prg.info@xantrex.com
www.xantrex.com