

Operating Instructions

Single Conveyor Unit SSV 05

Please note that our address and phone information has changed. Please reference this page for updated contact information.

CAUTION

These manuals are obsolete and are provided only for their technical information, data and capacities. Portions of these manuals detailing procedures or precautions in the operation, inspection, maintenance and repair of the products may be inadequate, inaccurate, and/or incomplete and shouldn't be relied upon. Please contact the ACS Group for more current information about these manuals and their warnings and precautions.

Parts and Service Department

The ACS Customer Service Group will provide your company with genuine OEM quality parts manufactured to engineering design specifications, which will maximize your equipment's performance and efficiency. To assist in expediting your phone or fax order, please have the model and serial number of your unit when you contact us. A customer replacement parts list is included in this manual for your convenience. ACS welcomes inquiries on all your parts needs and is dedicated to providing excellent customer service.

For immediate assistance, please contact:

- North, Central and South America, 8am – 5pm CST +1 (800) 483-3919 for drying, conveying, heating and cooling and automation. For size reduction: +1 (800) 229-2919.
North America, emergencies after 5pm CST (847) 439-5855
North America email: acsuscanadacustserv@corpemail.com
- Mexico, Central & South America
Email: acslatinamericacustserv@corpemail.com
- Europe, Middle East & Africa +48 22 390 9720
Email: acseuropecustserv@corpemail.com
- India +91 21 35329112
Email: acsindiacustserv@corpemail.com
- Asia/Australia +86 512 8717 1919
Email: acsasiacustserv@corpemail.com

Sales and Contracting Department

Our products are sold by a worldwide network of independent sales representatives. Contact our Sales Department for the name of the sales representative nearest you.

Let us install your system. The Contract Department offers any or all of these services: project planning; system packages including drawings; equipment, labor, and construction materials; and union or non-union installations.

For assistance with your sales or system contracting needs please Call:

North, Central and South America +1 (262) 641-8600 or +1 (847) 273-7700 Monday–Friday, 8am–5pm CST

Europe/Middle East/Africa +48 22 390 9720

India +91 21 35329112

Asia/Australia +86 512 8717 1919

Facilities:

ACS offers facilities around the world to service you no matter where you are located. For more information, please visit us at www.acscorporate.com

United States:

ACS Schaumburg – Corporate Offices

1100 E. Woodfield Road
Suite 588
Schaumburg, IL 60173
Phone: + 1 847 273 7700
Fax: + 1 847 273 7804

ACS New Berlin – Manufacturing Facility

2900 S. 160th Street
New Berlin, WI 53151
Phone : +1 262 641 8600
Fax: + 1 262 641 8653

Asia/Australia:

ACS Suzhou

109 Xingpu Road SIP
Suzhou, China 215126
Phone: + 86 8717 1919
Fax: +86 512 8717 1916

Europe/Middle East/Africa:

ACS Warsaw

Ul. Działkowa 115
02-234 Warszawa
Phone: + 48 22 390 9720
Fax: +48 22 390 9724

India

ACS India

Gat No. 191/1, Sandbhor Complex
Mhalunge, Chakan, Tal Khed,
Dist. Pune 410501, India
Phone: +91 21 35329112
Fax: + 91 20 40147576

Sterling Material Processing

5200 West Clinton Ave.

Milwaukee, WI 53223

Telephone: (414) 354-0970

Telefax: (414) 354-6421

www.sterlco.com

Technical service:

Service department

Telephone: **(800) 423-3183**

Edition: 08/99

This operation manual is for*:

(* Please fill in personally)

Serial number: _____

Built in: _____

Date of delivery: _____

Number of delivery: _____

Date of commissioning: _____

Location: _____

Group of machines: _____

Sterling Material Processing retains all rights to change the information in these operating instructions at any time without notice.

We assume no liability for any errors or direct or indirect damage resulting in context with these operating instructions.

Copying, translation or publication in any form except for personal use of purchaser requires approval from Sterling Material Processing.

All rights reserved.

Table of contents

1. Safety instructions	6
1.1. Warnings and symbols	7
1.2. Explanations and information	8
1.3. For your safety	9
1.4. For the safety of the units	12
2. Installation instructions	13
2.1. General information	14
2.2. Installing the conveyor hopper	15
2.3. Installing the control and maintenance unit	16
2.4. Connecting the compressed-air supply	17
2.5. Electrical connection	18
3. Functional description	19
3.1. Method of functioning	20
3.2. Control and maintenance unit	20
4. Set-up	21
4.1. Preparations	22
4.2. Basic setting of the filling level in the conveyor hopper	22
4.2.1. Fine adjustment of the filling level in the conveyor hopper	23
5. Maintenance	24
5.1. Maintenance intervals	26
5.2. Cleaning/replacing the filter cartridge	27
5.3. Adjusting the level probe	28
5.4. Trouble-shooting	29

6. Technical data	30
6.1. Dimension sheet	31
6.2. Spare parts list	32

1. Safety instructions



These safety instructions apply to all persons within the range of action of the equipment.

Please inform all persons within the range of action of the equipment of the direct and indirect hazards connected with the equipment.

These operating instructions are to be used by all persons assigned activities connected with the equipment.

Knowledge of the English language is prerequisite.

Ensure in each case that the operating personnel are familiar with the operating instructions and the function of the equipment.

1.1. Warnings and symbols

The following warnings and symbols are used in these operating instructions:



This symbol indicates danger to life! Fatal or serious injury is possible if the corresponding instructions, regulations or warnings are not observed.



This symbol indicates that serious injury is possible if the corresponding instructions, regulations or warnings are not observed.



This symbol indicates that extensive damage to equipment is possible if the corresponding instructions, regulations or warnings are not observed.



This symbol indicates information important for becoming familiar with the equipment, i.e. technical correlations.



This symbol indicates that a technical term is explained at this point.

1.2. Explanations and information

Various terms and designations are used frequently in these operating instructions to ensure clarity. Therefore please note that the terms used in the text stand for the corresponding explanations listed below.

- **Equipment**
"Equipment" can mean an individual unit, a machine or an installation.

- **Operating personnel**
The "operating personnel" are persons operating the equipment on their own responsibility or according to instructions (minimum age: 16).

- **Operator**
The "operator" of the equipment (production manager, foreman, etc.) is the person responsible for all production sequences. The operator instructs the operating personnel of what is to be done.

- **Operating instructions**
The "plant operating instructions" describe the interaction of the equipment, production sequences or methods. The plant operating instructions must be compiled by the operator of the equipment.

- **Equipment foreman**
When several operating personnel work on one machine, the "equipment foreman" coordinates the sequences. The equipment foreman must be appointed by the operator.

- **Trained personnel**
"Trained personnel" are persons who, due to their training, are authorized to carry out the required work in good practice.

1.3. For your safety

- The operators of this unit must be at least 16 years old.
- Before initial operation, read this operating manual carefully. Observe all points. Inquire in case of uncertainties.
This will avoid danger to persons and damage of material!
- Store this operating manual in such a way that it is always available on the site of operation for the unit. Faulty operation may lead to accidents!
- Note that, for reasons of clarity, not every possible case of operation or maintenance can be mentioned.
- Note the instructions for safety and the danger signs on the unit.
This will avoid danger to persons and damage of material!
- All work on the unit may only be carried out by persons whose qualification corresponds with the individual chapters of the operating manual.
Faulty operation may lead to accidents!
- For all types of work on the unit, proper working clothes must be worn.
This will avoid danger to persons!
- Compare the connected loads to those of the mains supply.
Danger of electrical shock!
- When using lifting gear, observe the specific instructions.
Danger of accidents!
- Observe the local regulations and requirements concerning the plant.
- Interrupt the mains supply for all types of work on electrical components.
Danger to life due to electrical shock!

- Do not carry through modifications, attachments or alterations of the unit without the manufacturer's permission. Danger of accidents!
- By means of this operating manual, prepare precise instructions for use of this unit. Faulty operation may lead to accidents!
- Designate a unit leader responsible for the unit.
- In any case, the operators of this unit must be thoroughly instructed. Faulty operation may lead to accidents!
- If the unit has been switched off for reasons of safety, it must be protected from unauthorised activation. Danger of accidents!
- Before beginning maintenance work, designate a supervisor.
- Before beginning maintenance work, inform the responsible operating personnel. Danger of accidents!
- Before beginning maintenance work, interrupt the mains supply so that the unit is not switched on unintentionally. Danger of accidents!
- Repair work may only be carried through by trained personnel. Danger of accidents!
- The unit may never be operated when it is partially disassembled. Limbs may be drawn in! Electrical shock!
- In case of functional disturbances, switch off the unit immediately. Errors must be eliminated immediately. Danger of accidents!
- The unit is exclusively intended for conveying plastic granules and regrind. Any other usage is not permitted.
- This unit is not suitable for processing foods.

- Attachments which are not delivered by Sterling must be constructed according to the safety standard EN 294. Danger of accidents!
- Check all lines, hoses and coupling pieces in regular intervals for leakages and damage. Any errors must be eliminated immediately. Danger of accidents!
- Before beginning maintenance work, set all compressed-air lines on the unit at zero pressure. Danger of accidents!
- The unit may only be operated if all corresponding components have been properly connected and are in accordance with the relevant regulations.
- Observe the safety instructions for the connected units.

1.4. For the safety of the units

- The unit may only be used for conveying free flowing pellettized plastic materials on injection moulding machines.
- Never change settings unless you are able to precisely foresee the consequences.
- Use only original Sterling spare parts.
- Observe the maintenance intervals.
- Keep a book on all maintenance and repair work.
- Note that electronic subassemblies may be damaged by static discharge.
- Before initial operation and in regular intervals, check all electrical connections for proper fit.
- Never modify sensors without knowing their precise functions.
- Make sure that all plugs are connected properly.
- Observe the carrying capacity of the machine flange.
- Observe the operating manuals of the connected units.

2. Installation instructions



These installation instructions are intended for persons with skills in electrical and mechanical areas due to their training, experience and received instructions.

Personnel using these installation instructions must be instructed in the regulations for the prevention of accidents, the operating conditions and safety regulations and their implementation.

Ensure in each case that the personnel are informed.

The installation instructions provided in the corresponding operating instructions apply for all connected equipment.

Observe safety regulations with regard to lifting gear handling.

All installation work must be carried out with the equipment disconnected from electrical power and compressed air supply.



For installation work taking place at heights of over approx. 1829 mm (6 ft.), use only ladders or similar equipment and working platforms intended for this purpose. At greater heights, the proper equipment for protection against falling must be worn.

Use only suitable lifting gear which is in proper working order and load suspension devices with sufficient carrying capacity. Do not stand or work under suspended loads!

Use suitable workshop equipment.



Install the equipment such that all parts are easily accessible; this facilitates maintenance and repair work.

2.1. General information

Unpack all parts of the single conveyor unit and make sure that everything is available:

- conveyor hopper with level probe (1)
- control and maintenance unit (2)
- injector tube (3)
- supply hose (4) with 2 hose clamps
- compressed-air hose
- operating instructions

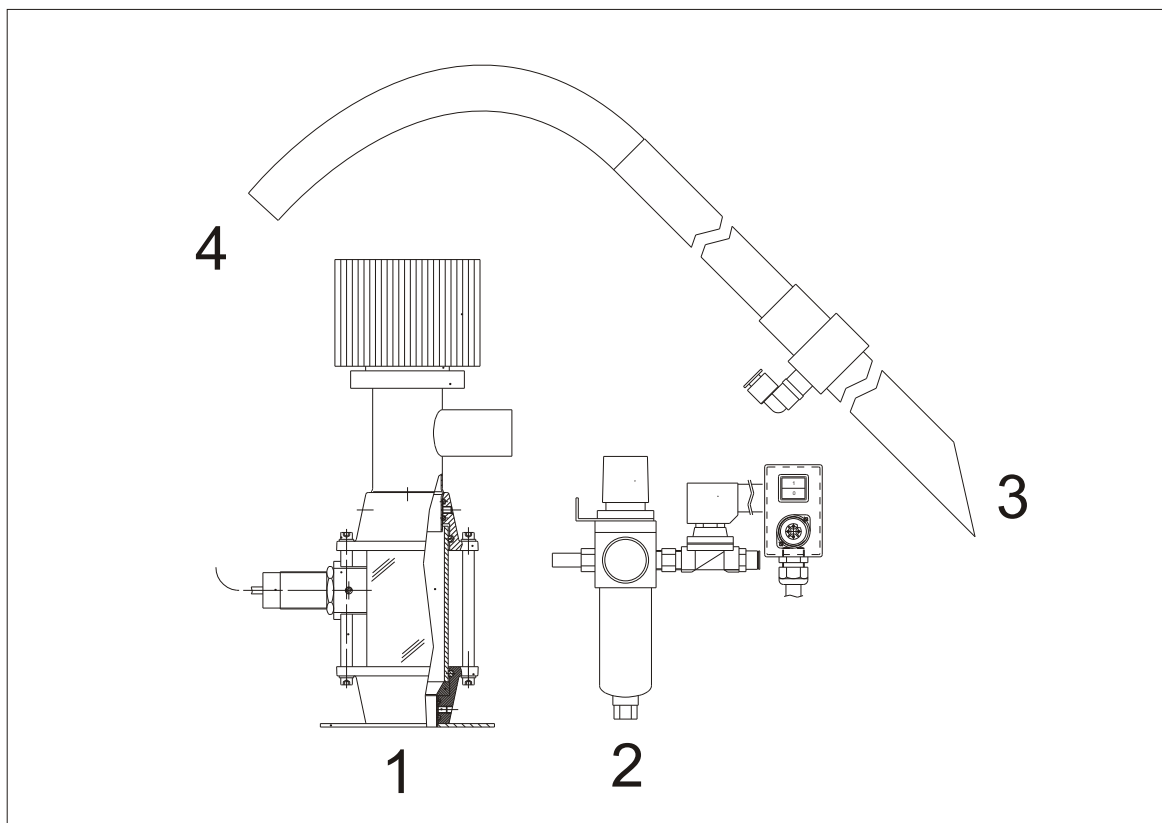

2.2. Installing the conveyor hopper

The single conveyor unit is not sensitive to shocks and can be installed directly on the processing machine.

Make sure that all connections are tight so that the conveying performance is not impaired.

The conveyor hopper is equipped with a universal flange.

Depending on the position, drill the holes for fastening the conveyor hopper to the processing machine.

Mount the conveyor hopper on the processing machine.

Install the supply hose on the conveyor hopper and on the injector tube by means of the hose clamps which are part of the supply.



Note that the hopper may not touch any other component.

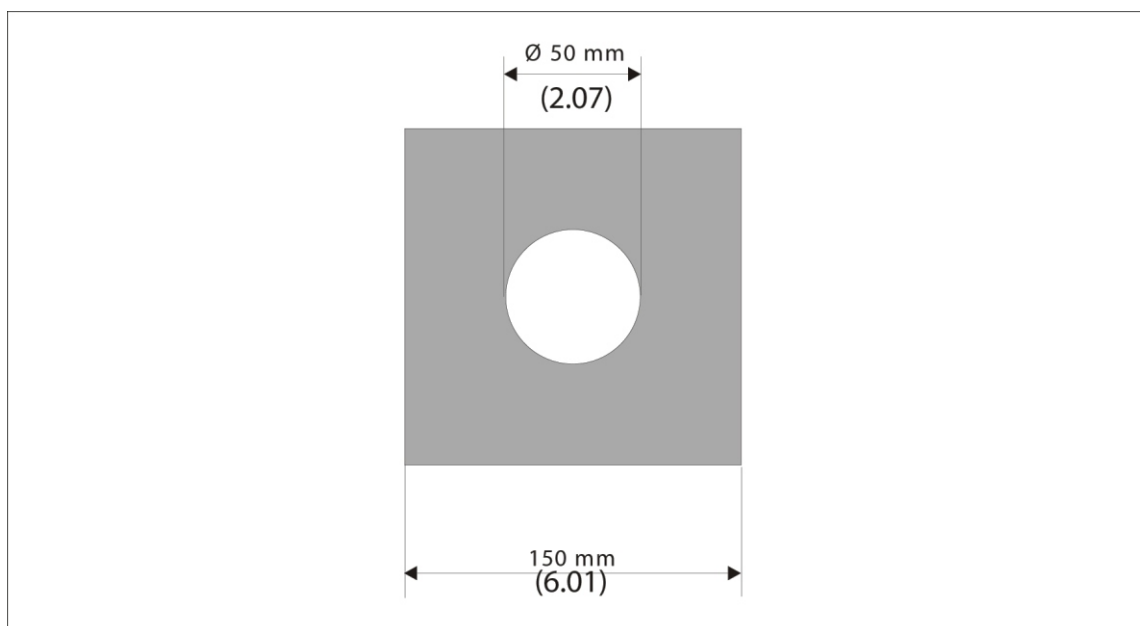

2.3. Installing the control and maintenance unit

Install the control and maintenance unit at a freely accessible site. Observe the length of the connection cable and of the supplied hoses to the injector tube.

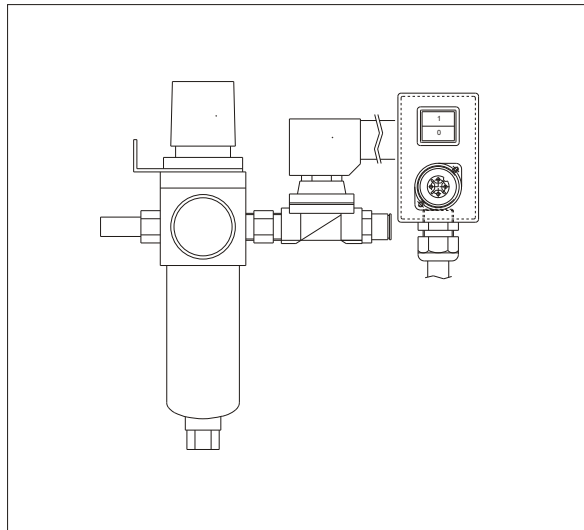

During installation, observe the length of the supply lines.

2.4. Connecting the compressed-air supply

Check compressed-air piping for correct installation and assembly.

Check fittings, length and quality of the hose connections for agreement with requirements.

Check all compressed-air lines for leakages.

You need a compressed-air supply with 5 - 6 bar (72.52-87.02 PSI) system overpressure. The air should be free from oil and water, if possible.

Connect the compressed-air hose, which is part of the supply, to the injector tube and to the control and maintenance unit. To this end, the compressed-air hose is firmly pressed into the connecting sockets.

Connect the control and maintenance unit to the compressed-air supply (max. input pressure 10 bar (145.03 PSI) system overpressure).

Set the pressure on the pressure reducer at 5 - 6 bar (72.52-87.02) PSI.

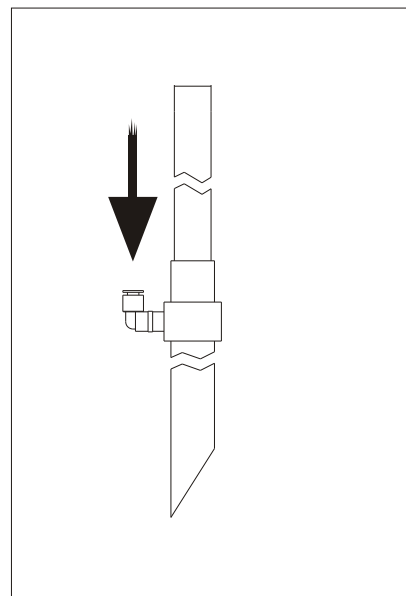

Maximum input pressure 10 bar (145.03 PSI) (system overpressure).

Maximum output pressure 6 bar (87.02 PSI).

2.5. Electrical connection



Observe the regulations of the local electricity board.

The operating voltage is 230 V, AC, PE, 50/60 Hz.
Special voltages available on request.

The connected load is approx. 15 W.

The connection takes place by means of a mains connector.

A separate protection of the socket is not necessary.

Connect the plug of the probe cable to the control unit.

Plug the mains connector into a corresponding socket.

3. Functional description



This functional description is intended for the operating personnel of the equipment.

General knowledge of operating conveyor units is a prerequisite.

Ensure in each case that the operating personnel are sufficiently informed.



The single conveyor unit SSV 05 is designed for conveying free flowing pellettized plastic materials directly on the injection molding machine.

3.1. Method of functioning

The single conveyor unit works according to the venturi principle. An external compressed-air supply is needed.

A venturi meter (A) is integrated in the injector tube. The venturi meter aspirates the material in the lower part of the tube (C) and then conveys the material into the conveyor hopper by means of compressed air in the upper part (B). In the hopper loader, the material is separated from the air.

The filling level in the conveyor hopper is monitored and controlled by means of a level probe.

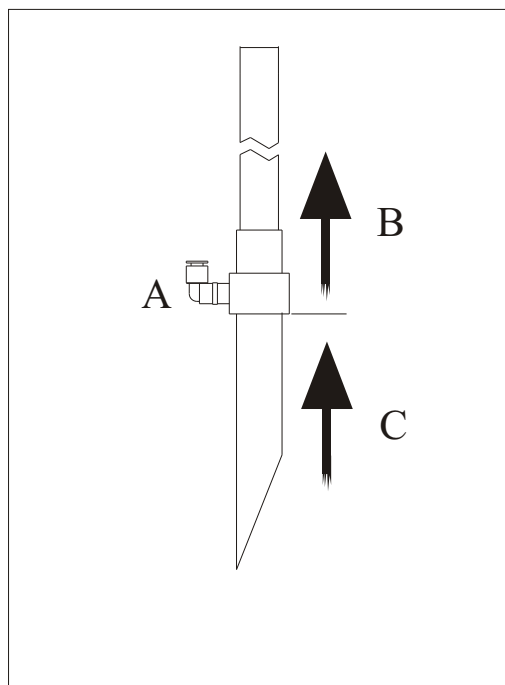

3.2. Control and maintenance unit

The unit is switched on and off at the control and maintenance unit.

On the pressure reducer, the operating pressure is adjusted. A water separator is integrated.

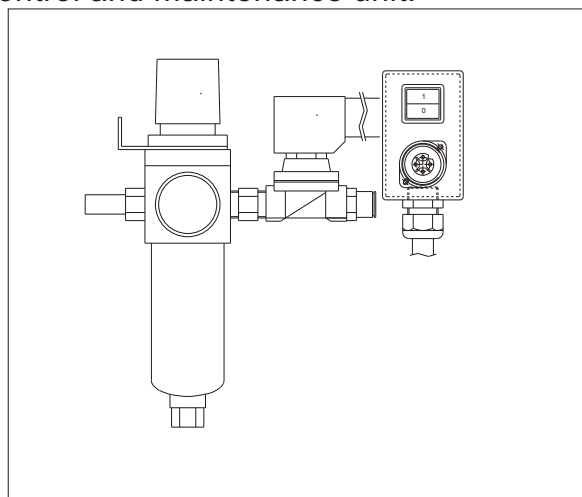

4. Set-up



This chapter is intended for the operating personnel of the equipment.

General knowledge of operating conveyor units is prerequisite.

The functional description must have been read and understood.

Ensure in each case that the operating personnel are sufficiently informed.

4.1. Preparations

Check whether the injector tube is inserted in the material to be conveyed.

Switch on the compressed-air supply.

Switch on the conveyor unit at the control and maintenance unit.

The conveyor unit should now convey until the conveyor hopper is filled up to the level probe.

4.2. Basic setting of the filling level in the conveyor hopper

The filling level in the conveyor hopper is mainly determined by the level probe.

Filling level too low

By means of a screwdriver, turn the adjustment screw of the level probe (A) $\frac{1}{4}$ rotation counterclockwise.

Observe the filling level during the next conveying procedure.

Repeat the process until the desired filling level in the conveyor hopper is reached.

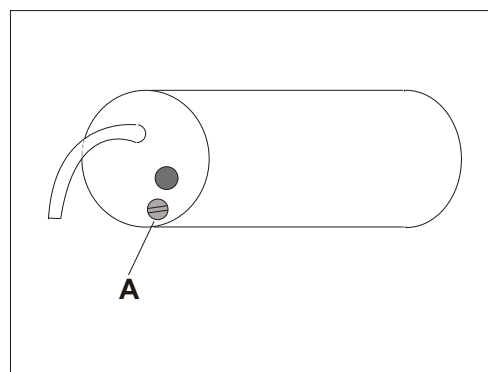

Filling level too high

By means of a screwdriver, turn the adjustment screw (A) of the level probe $\frac{1}{4}$ rotation clockwise.

Observe the filling level during the next conveying procedure.

Repeat the process until the desired filling level in the conveyor hopper is reached.

4.2.1. Fine adjustment of the filling level in the conveyor hopper



Before the fine adjustment, carry through a basic adjustment.

During operation, carefully turn the adjustment screw (A) of the level probe by means of a screwdriver until the desired filling level is reached.

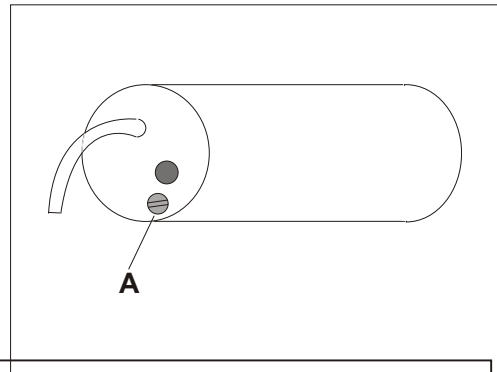

Clockwise rotation makes the filling level fall.

Counterclockwise rotation makes the filling level rise.

If the filling level in the conveyor hopper cannot be lowered far enough by means of the level probe, the pressure on the control and maintenance unit can be reduced step by step.

5. Maintenance



This chapter is intended for persons with skills in electrical and mechanical areas due to their training, experience and received instructions.

Personnel using the instructions in this chapter must be instructed of the regulations for the prevention of accidents, the operating conditions and safety regulations and their implementation.

Ensure in each case that the personnel are informed accordingly.

For maintenance work taking place at heights of over approx. 6 feet (1829)mm, use only ladders or similar equipment and working platforms intended for this purpose. At greater heights, the proper equipment for protection against falling must be worn.

Use only suitable lifting gear which is in proper working order and load suspension devices with sufficient carrying capacity. Do not stand or work under suspended loads!

Ensure that the electric motors/switch cabinets are sufficiently protected against moisture.

Use only suitable workshop equipment.

Before starting maintenance work, appoint a supervisor.

Inform the responsible personnel before maintenance work on the system is started.

Never operate the equipment when partially dismantled.

All maintenance and repair work not described in this chapter may only be carried out by Sterlingservice personnel or authorized personnel (appointed by Sterling).



Disconnect the equipment from mains supply before starting maintenance procedures to ensure that it cannot be switched on unintentionally.

Depressurize all compressed air piping of the equipment before starting maintenance work.



Please observe the maintenance intervals.

Before starting maintenance work, clean the equipment of oil, fuel or lubricants.

Ensure that materials and incidentals required for operation as well as spare parts are disposed of properly and in an environmentally sound manner.

Use only original Sterling spare parts.

Keep record of all maintenance and repair procedures.

5.1. Maintenance intervals

daily: Check the setting of the pressure reducer.
Empty the water separator.

Check the danger signs on the unit for legibility
and completeness.

monthly: Clean the filter and sieve
(depending on accumulation of dust!).
Blow out the filter from the inside out by means
of compressed air.

Check the unit plugs for proper functioning.

every six months: Check all electrical and mechanical connections
for proper fit.

Replace the filter and the sieve
(depending on accumulation of dust!).



The given maintenance intervals are average values.

Check whether in your individual case the maintenance intervals must be shortened.

5.2. Cleaning/replacing the filter cartridge



Switch off the unit.

Disconnect the mains plug.

Disassembly

Remove the filter cartridge (A).

Blow out the filter cartridge (A) from the inside out by means of compressed air or replace the filter.

Open the tension ring (B).

Remove the nozzle (C) and the sieve (D).

Check the sieve (D) for material residue. Clean the sieve (D) by means of compressed-air. Replace the sieve and sealing ring in case of damage.

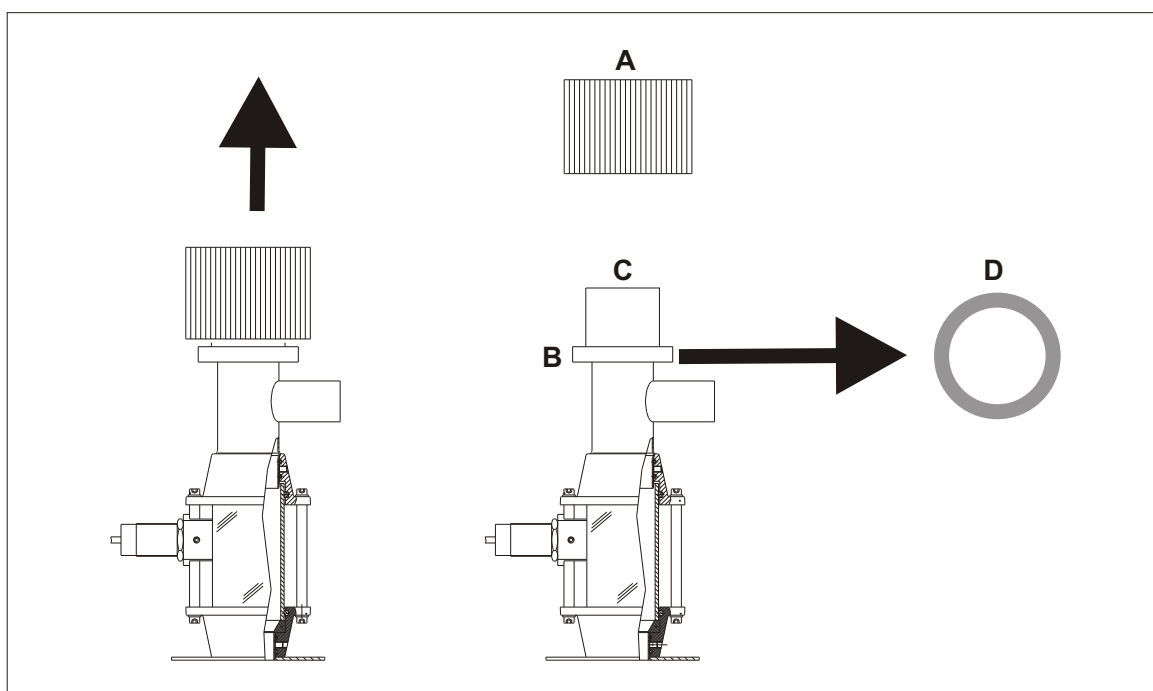

Assembly

Assemble the sieve and the sealing ring.

Mount the nozzle

Mount the tension ring

Assemble the filter cartridge.



Order number filter cartridge:	ID 98171
Sieve:	ID 18491
Sealing ring:	ID 31160

5.3. Adjusting the level probe



See chapter “set-up”.



Order number level probe:	ID 85480
------------------------------	----------

5.4. Trouble-shooting

Problem	Remedy
The unit is not conveying and is not active	a, b, g, h
The unit is not conveying; the compressed-air valve is switched when the device is switched on	c, f
The unit is not conveying, the compressed air is flowing audibly	c, d, e, f, i, j, k
The unit is overfilled	g, l, m
The unit is not filled properly	c, d, e, f, i, j, k, l

Test steps

- a) Check whether the unit is switched on.
- b) Check whether the mains connector is connected and mains voltage is present.
- c) Check whether sufficient compressed air is available.
- d) Check whether the injector tube is inserted in the material.
- e) Check whether the compressed-air hose is properly connected to the injector tube.
- f) Check whether the compressed-air hose is properly connected to the maintenance unit.
- g) Check whether the level probe is properly adjusted.
- h) Check whether the cable of the level probe is properly connected.
- i) Check whether the filter is clogged.
- j) Check whether the sieve is clogged.
- k) Check whether the conveyor hose is properly connected.
- l) Check whether the compressed-air supply is properly adjusted.

6. Technical data

Max. permissible shot weight
of the injection moulding machine: 100 kg/h (with 0.6 kg/l)
(220.56 lbs/h) (with 1.32 lbs/l)

Weight: approx. 3 kg
(6.61 lbs.)

Operating voltage: 230 V, AC, PE, 50/60 Hz
Special voltage on request

Connected load: approx. 15 W
(0.02 hp)

Total noise level: < 75 dB (A)

Compressed-air supply: 5-6 bar (system overpressure)
(72.52-87.02 PSI)

Max. product temperature: 80 °C
(176°F)

6.1. Dimension sheet

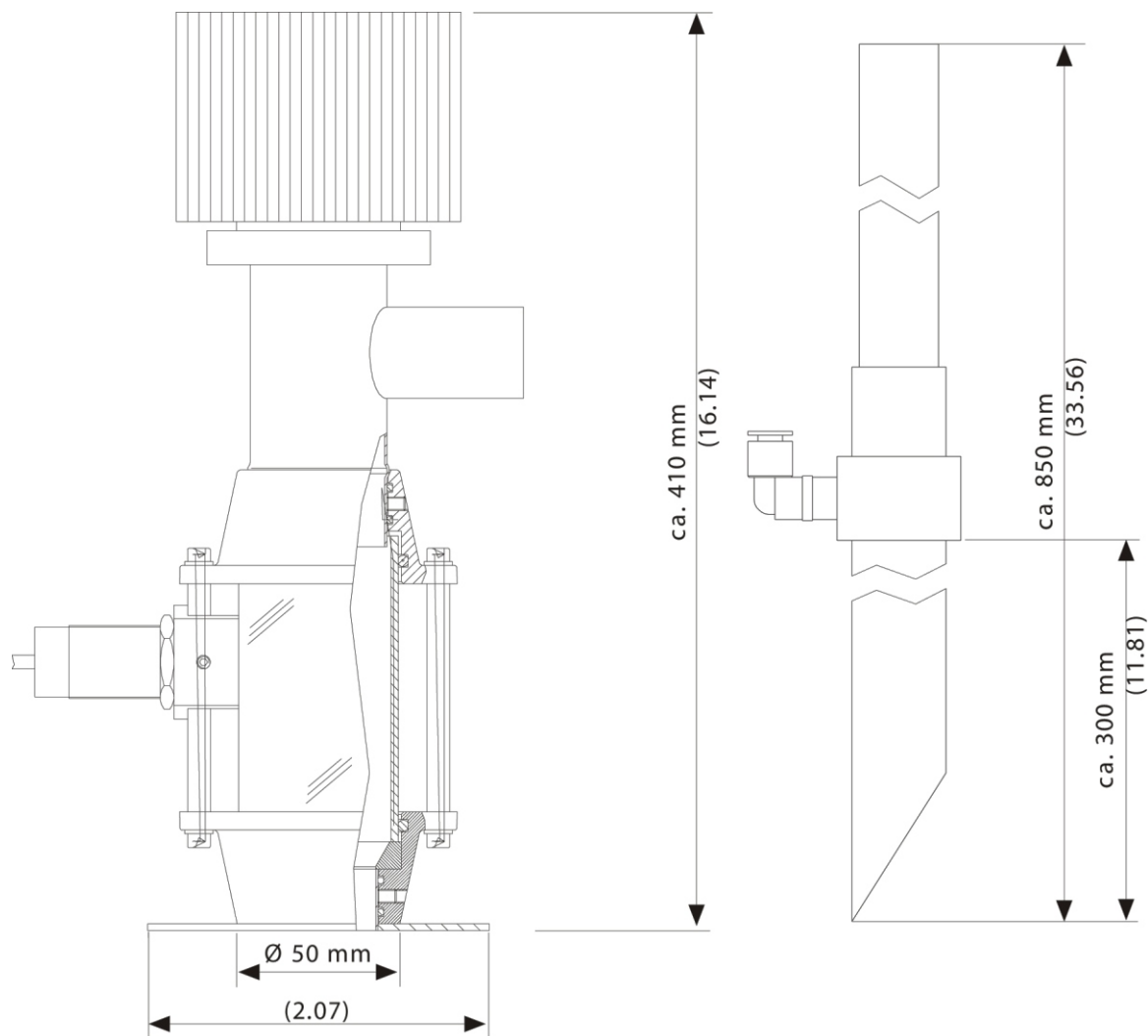

Dimensions and data are not binding. All dimensions are in mm. (in.) All data are subject to change.

6.2. Spare parts list

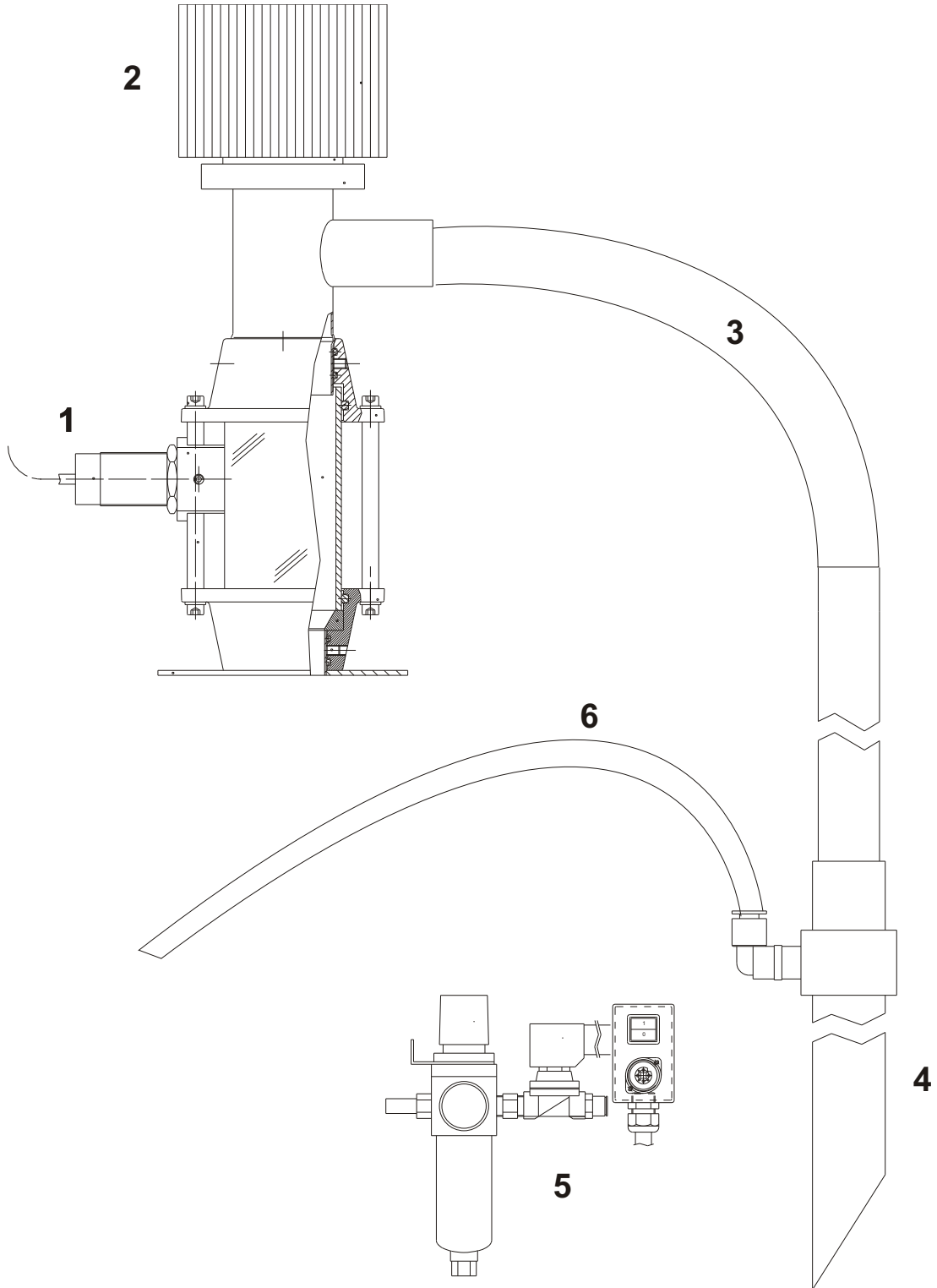

Pos.	ID-No.	Designation
1	85480	level probe
2	98171	filter cartridge
	18491	sieve
	31160	sealing ring
3	84426	conveyor hose
	97784	hose clamp
4	31683	injector tube
5	29370	maintenance and control unit
	84415	filter insert
	84414	coil
	84413	repair set fittings
	84412	cable plug housing
6	88351	compressed-air hose