

DA-682 Series

x86-based rackmount computers with VGA, 4 Gigabit Ethernet ports, 2 peripheral expansion slots, CompactFlash, USB



- > Intel Celeron M 1 GHz processor with 400 MHz FSB
- > Built-in DDR2 SDRAM and industrial flash disk module
- > Quad Gigabit Ethernet ports for network redundancy
- > Software selectable RS-232/422/485 with 2 KV isolation protection
- > PCI expansion slots for inserting expansion modules
- > 1 CompactFlash socket for storage expansion
- > USB 2.0 ports for high speed peripherals, supporting system bootup
- > 19-inch rackmount, 2U high form factor
- > 100/240 VAC/VDC power inputs
- > Ready-to-Run Linux, WinCE 6.0, or Windows XP Embedded platform
- > Fanless design

The certification logos shown here apply to some or all of the products in this section. For details, see "Regulatory Approvals" under "Specifications" below.



Overview

The DA-682 computers are based on the Intel x86 processor and support VGA, 4 Gigabit Ethernet ports, 8 RS-232/422/485 serial ports with optical isolation, CompactFlash, and USB. The DA-682 comes in a standard 19-inch, 2U high form factor.

With their robust design, the DA-682 computers are suitable for industrial automation applications that require standard 19-inch rackmount solutions, such as power automation, transportation, and oil and gas. Another plus is that the serial ports come with 2 KV optical isolation protection to guarantee communication reliability in harsh industrial environments.

The DA-682 computers run Linux, WinCE 6.0, or Windows XP

Embedded (pre-installed), providing a friendly environment for developing sophisticated application software. The great software support that Moxa provides makes the programmer's job easier, and helps programmers develop bug-free code quickly and at a lower cost.

The DA-682 comes with 2 PCI slots for inserting expansion modules. Moxa provides a variety of communication modules, including an 8-port RS-232/422/485 module, a 4-port 10/100 Mbps LAN module, and a universal PCI expansion module. The friendly design gives users the advantage of being able to swap out modules quickly and easily.

These features make the DA-682 an ideal solution for use with a wide array of industrial automation applications.

Appearance

Front View

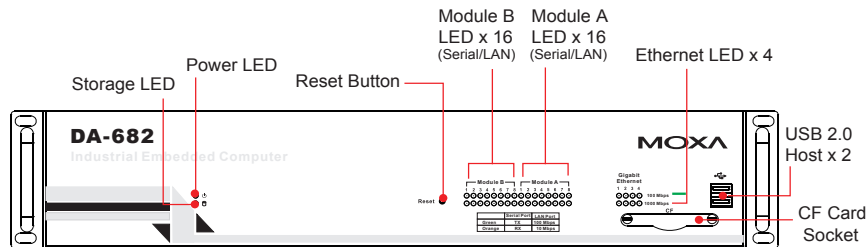

Rear View

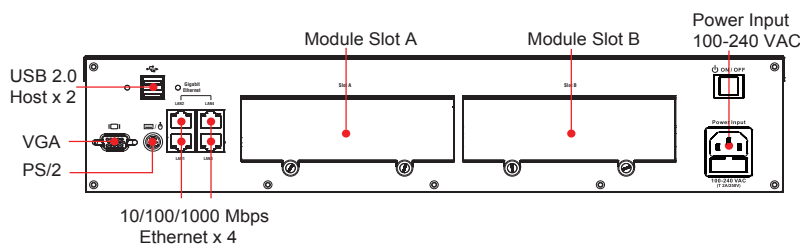

Expansion Modules

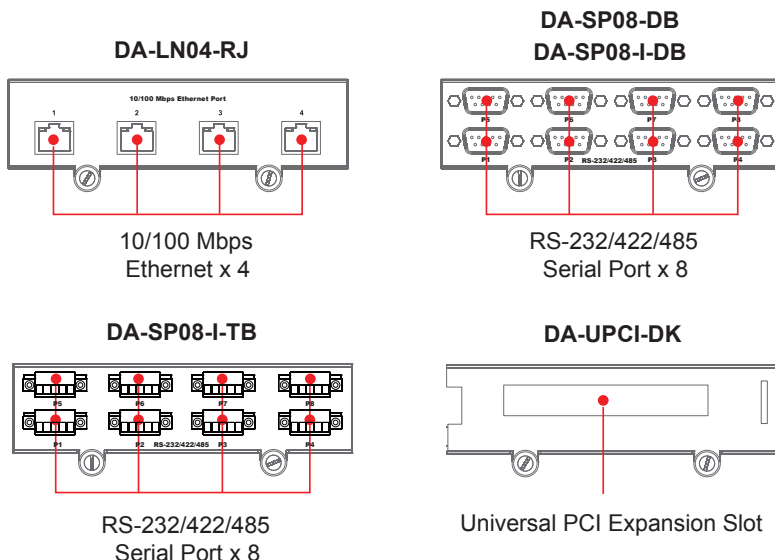

Hardware Specifications

Computer

- CPU:** Intel Celeron M 1 GHz processor
- OS (pre-installed):** Linux, WinCE 6.0, or Windows XP Embedded SP2
- System Chipset:** Intel 915GME + ICH6M chipset
- BIOS:** 4 mega-bit Flash BIOS, PCI Plug & Play, ACPI function support
- FSB:** 400/533 MHz
- System Memory:** 1 x 200-pin DDR2 SODIMM socket supporting DDR2 400/533; up to 1 GB max. (512 MB for WinXPe/Linux, 256 MB for WinCE 6.0)
- Expansion Bus:** PC/104-Plus onboard
- USB:** USB 2.0 compliant hosts x 4, Type A connector, supports system boot up

Storage

- Built-in:** 256 MB (CE) or 1 GB (WinXPe/Linux) industrial DOM for OS
- Storage Expansion:** CompactFlash socket

Other Peripherals

- KB/MS:** 1 PS/2 interface, supports standard PS/2 keyboard and PS/2 mouse

Display

- Graphics Controller:** Integrated graphics with built-in Intel 915GME, and built-in Intel extreme Graphics 2 technology
- Display Memory:** Dynamic video memory (shares up to 32 MB of system memory)
- Display Interface:** CRT Interface for VGA output (DB15 female connector)
- Resolution:** CRT display mode with pixel resolution up to 2548 x 1536 at 75 Hz

Ethernet Interface

- LAN:** 4 auto-sensing 10/100/1000 Mbps Gigabit ports (Realtek RTL8110SC controller)
- Magnetic Isolation Protection:** 1.5 KV built-in

LEDs

- System:** Power, Storage
- Gigabit LAN:** 100M x 4, 1000M x 4

- LAN:** 10/100M mode
- Serial:** TX/RX
- Communication:** Module A x 16, Module B x16
- Switches and Buttons**
 - Power Switch:** on/off (on rear panel)
 - Reset Button:** To reset system hardware (on front panel)
- Physical Characteristics**
 - Housing:** SECC sheet metal (1 mm)
 - Weight:** 7 kg
 - Dimensions:** 440 x 253 x 90 mm (17.32 x 9.96 x 3.54 in) (without rackmount ears)
 - Mounting:** Standard 19-inch rackmount
- Environmental Limits**
 - Operating Temperature:** -10 to 60°C (14 to 140°F)
 - Operating Humidity:** 5 to 95% RH
 - Storage Temperature:** -20 to 80°C (-4 to 176°F)
- Power Requirements**
 - Input Voltage:** 100 to 240 VAC/VDC auto-ranging (47 to 63 Hz for AC input)
 - Power Consumption:** 30 W (full loading)
- Regulatory Approvals**
 - EMC:** CE (EN61000-6-4, EN61000-3-2, EN61000-3-3, EN55024), FCC (Part 15 Subpart B, CISPR 22 Class A), CCC (GB9254, GB 17625.1)
 - Safety:** UL/cUL (UL60950-1, CSA C22.2 No. 60950-1-03), LVD (EN60950-1), CCC (GB4943)
- Reliability**
 - Alert Tools:** Built-in buzzer and RTC (real-time clock) with battery lithium backup
 - Automatic Reboot Trigger:** Built-in WDT (watchdog timer) supporting 1-255 level time interval system reset, software programmable
- Warranty**
 - Warranty Period:** 5 years
 - Details:** See www.moxa.com/warranty

: DA-SP08-DB/DA-SP08-I-DB/TB (module with 8 serial ports)

Serial Interface

Serial Standards: 8 RS-232/422/485 ports, software-selectable (DB9 male or terminal block connector)

ESD Protection: 15 KV for all signals

Isolation: 2 KV digital isolation

Serial Communication Parameters

Data Bits: 5, 6, 7, 8

Stop Bits: 1, 1.5, 2

Parity: None, Even, Odd, Space, Mark

Flow Control: RTS/CTS, XON/XOFF, ADDC® (automatic data direction control) for RS-485

Baudrate: 50 bps to 921.6 Kbps (non-standard baudrates supported; see user's manual for details)

Serial Signals

RS-232: TxD, RxD, DTR, DSR, RTS, CTS, DCD, GND

RS-422: TxD+, TxD-, RxD+, RxD-, GND

RS-485-4w: TxD+, TxD-, RxD+, RxD-, GND

RS-485-2w: Data+, Data-, GND

: DA-LN04-RJ (module with 4 LAN ports)

Ethernet Interface

LAN: Auto-sensing 10/100 Mbps Ethernet x 4, RJ45 connectors

Magnetic Isolation Protection: 1.5 KV built-in

: DA-UPCI-DK (module with 1 Universal PCI expansion slot)

Universal PCI Expansion Adaptor

PCI Slots: 1

Interface Bus: 32-bit Universal PCI (3.3 V and 5 V)

: Software Specifications

Linux

Distribution: Debian Etch 4.0 r2

Kernel Version: 2.6.18

Protocol Stack: TCP, UDP, IPv4, SNMP V1, ICMP, ARP, HTTP, CHAP, PAP, SSH 1.0/2.0, SSL, DHCP, NTP, NFS, Telnet, FTP, PPP, PPPoE

File System: EXT2, JFFS2 (1G DOM)

System Utilities: bash, busybox, login, telnet, ftp, ssh, openssh-inetd, apt, apt-utils, dpkg, grub, udev

telnetd: telnet Server daemon

ftpd: FTP server daemon

sshd: secure shell server

Apache: web server daemon, supporting PHP and XML

Openvpn: virtual private network service manager

iptables: Firewall service manager

NAT: Network Address Translation

pppd: dial in/out over serial port daemon & PPPoE

pppoe: PPP over ethernet

tftp/tftpd: Trivial file transfer protocol client/server

snmpd: snmpd agent daemon

usbmount: support USB PnP

DHCP Client: dhcp3-client

cron: management of regular background processing

grep: NU grep, egrep and fgrep

minicom: friendly serial communication program

watchdog: software watchdog

inetd: TCP server manager program

Application Development Environment: GNU Make 3.8.1 (GNU make utility to maintain groups of programs)

Automatic configuration script builder: autoconf 2.13

gcc: GNU C compiler

g++: GNU C++ compiler

libc6-dev: GNU C Library (development libraries and headers)

Perl: Practical Extraction and Report Language

Vim: Vi Improved - enhanced vi editor

Windows Embedded CE 6.0

System Utilities: Windows command shell, telnet, ftp, web-based administration manager

File System: FAT (on-board flash)

Protocol Stack: TCP, UDP, IPv4, SNMP V2, ICMP, IGMP, ARP, HTTP, CHAP, PAP, SSL, DHCP, SNTP, SMTP, Telnet, FTP, PPP

Telnet Server: Allows remote administration through a standard telnet client.

FTP Server: Used for transferring files to and from remote computer systems over a network.

File Server: Enables clients to access files and other resources over the network (Microsoft® Windows® CE).

Web Server (httpd): Includes ASP, ISAPI Secure Socket Layer support, SSL 2, SSL 3, and Transport Layer Security (TLS/SSL 3.1) public key-based protocols, and Web Administration ISAPI Extensions.

Dial-up Networking Service: RAS client API and PPP, supporting Extensible Authentication Protocol (EAP) and RAS scripting.

Watchdog Service: CPU Hardware function to reset CPU in a user specified time interval (triggered by calling a MOXA library function).

Application Development Environment:

- Moxa WinCE 6.0 SDK
- C Libraries and Run-times
- Component Services (COM and DCOM)
- Microsoft® .NET Compact Framework 2.0 SP2
- XML, including DOM, XQL, XPATH, XSLT, SAX, SAX2
- SOAP Toolkit Client
- Winsock 2.2

Windows XP Embedded

System Utilities: Windows command shell, Telnet, ftp, web-based administration manager, Wireless Zero Configuration

File System: NTFS

Protocol Stack: DHCP, IPv4, DNS, IPsec, HTTP, TCP, UDP, ICMP, IGMP, ARP, TAPI, TSP, SNMP V2, NTP, ICS, PPP, CHAP, EAP, SNTP, Telnet, FTP, SMTP, PPPoE, PPTP, NetBIOS

Telnet Server: Allows users to connect to Telnet servers from remote computers.

IIS Web Server: Allows you to create and manage Web sites.

Terminal Server: Microsoft Terminal Server client application (mstsc.exe).

COM+ Services: The next evolution of Microsoft Component Object Model (COM) and Microsoft Transaction Server (MTS).

Computer Browser Service: Computer browsing functionality exposed by Windows through Microsoft Networking. Allows a client machine to browse its network neighborhood for available computers exposing file and print sharing services.

Disk Management Services: Support for disk and volume management operations. The component implements a Component Object Model (COM) interface that can be used to query and configure disks and volumes, both basic and dynamic. The component also monitors disk arrivals and removals and other changes in the storage subsystem.

Remote Registry Service: Enables remote users to modify registry settings on this computer.

Application Development Environment:

- Microsoft .Net Framework 2.0 with service pack 2 (CLR and the .NET Framework class library)
- Active Directory Service Interface (ADSI) Core
- Active Template Library (ATL), ASP.NET 2.0
- Certificate Request Client & Certificate
- Autoenrollment (CLR and the .NET Framework class library)
- COM APIs
- Common Control Libraries
- Common File Dialogs
- Direct3D, DirectPlay, DirectShow and Direct show filters
- Distributed Transaction Coordinator (MSDTC)
- Enhanced Write Filter (Redirect disk write operations to volatile (RAM) or non-volatile (disk) storage)
- Event Log, Internet Explorer
- Mapi32 Libraries
- Message Queuing (MSMQ) Core
- Microsoft Visual C++ Run Time Libraries
- Power Management dynamic-link library
- Registry Editor
- RPC
- Smart Card Cryptographic Service Providers
- USB 2.0 core drivers compliant with USB .95 or 1.0
- Windows API, Media Player 10, Script Engines, and WMI

Dimensions

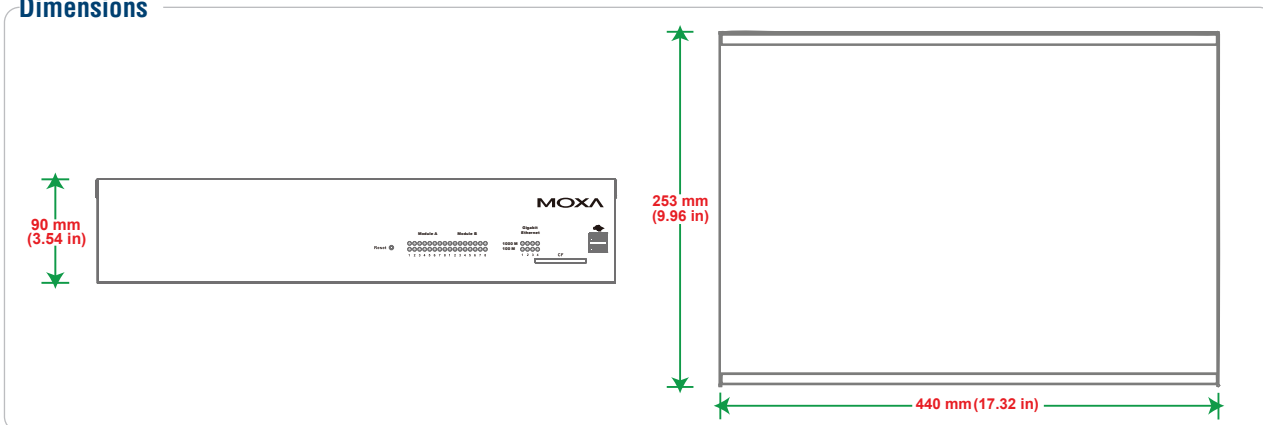

Ordering Information

Available Models

DA-682-CE: x86 rackmount computer with VGA, 4 Gigabit Ethernet ports, 2 PCI slots, CompactFlash, USB, WinCE 6.0

DA-682-XPE: x86 rackmount computer with VGA, 4 Gigabit Ethernet ports, 2 PCI slots, CompactFlash, USB, WinXPe

DA-682-LX: x86 rackmount computer with VGA, 4 Gigabit Ethernet ports, 2 PCI slots, CompactFlash, USB, Linux

Expansion Modules (can be purchased separately)

DA-SP08-I-DB: 8-port RS-232/422/485 serial module with DB9 connector and digital isolation

DA-SP08-DB: 8-port RS-232/422/485 serial module with DB9 connector

DA-SP08-I-TB: 8-port RS-232/422/485 serial module with terminal block connector and digital isolation

DA-LN04-RJ: 4-port 10/100 Mbps LAN module

DA-UPCI-DK: Universal PCI development kit

Package Checklist

- DA-682 embedded computer
- Ethernet cable: RJ45 to RJ45 cross-over cable, 100 cm
- AC power cable
- Document and Software CD or DVD
- Quick Installation Guide (printed)
- Warranty Card