

# HIFI MICRO SYSTEM



**Ovation  
CDS 6580 SPCD**

**DEUTSCH  
ENGLISH  
FRANÇAIS  
ITALIANO  
PORTUGUÊS  
ESPAÑOL**

# GERUNDIG

# CONTENTS

---

- 3**      **Set-up and safety**  
Magic Fidelity. The sound concept from Ovation
- 4**      **Overview**  
The hi-fi system controls  
The hi-fi system displays  
The remote control
- 12**     **Connection and preparation**
- 15**     **Settings**  
Setting the time  
Tuning and storing radio position  
Reset
- 18**     **General functions**
- 20**     **Tuner mode**  
Selecting the TUNER input source  
Selecting a preset station  
Stereo/mono reception  
Automatic station search (ASP)  
RDS station service
- 23**     **CD mode**  
Selecting the CD input source  
Inserting a CD  
Playing back a CD  
Repeating the current file or track  
Selecting another file or track  
Searching for a passage within a file or track  
Selecting albums and files (MP3 only)  
Calling up track information (MP3 only)  
Repeating a file or a track (Repeat One)  
Repeating all the files on an album (MP3 only)  
Repeating all files or tracks (Repeat All)  
Playing back files or tracks in random order (Random)  
Playing the introductions of files or tracks (Intro)  
Creating a track memory
- 30**     **Timer mode**  
Switch-on timer  
Reminder timer  
Sleep timer
- 33**     **Information**  
Cleaning the CD unit  
Technical data  
Environmental note  
General instructions for laser devices  
Troubleshooting

# SET-UP AND SAFETY

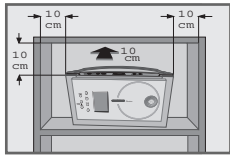

Please note the following information when setting up the system:

The hi-fi system is designed for the playback of audio signals. Any other use is expressly prohibited.

If you want to set up the hi-fi system on wall shelves or in cupboards, please ensure that it is adequately ventilated. There must be at least 10 cm of space at the side, above and behind the hi-fi system.

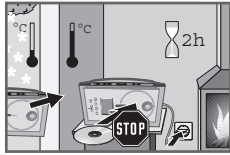

Please note when setting up the hi-fi system that furniture surfaces are coated with various types of paint and plastic, which often contain chemical additives. These additives may cause corrosion to the feet of the unit. This may leave stains on the surface of the furniture which can be difficult or impossible to remove.

If the hi-fi system is exposed to sudden changes in temperature, for example when taken from the cold into a warm room, wait at least two hours before using it.

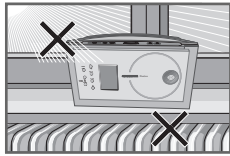

The hi-fi system is designed for use in dry rooms. If you do use it outside, please ensure that it is protected from moisture, such as rain or water splashes.

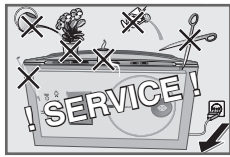

Do not place the hi-fi system close to heating units or in direct sunlight, as this will impair cooling.

Do not place any vessels containing liquids, such as vases, on the hi-fi system. Do not insert any foreign bodies in the CD compartment. Do not place any objects such as burning candles on the hi-fi system.

Do not open the hi-fi system casing under any circumstances. Warranty claims are excluded for damage resulting from improper handling.



Thunderstorms are a danger to all electrical devices. Even if the hi-fi system is switched off, it can be damaged by a lightning strike to the mains or the antenna cable. Always disconnect the mains and antenna plugs during a storm.

## Magic Fidelity.

### The sound concept from Ovation.

Magic Fidelity is a new, three-channel active loudspeaker system developed and patented by Grundig, which produces powerful and brilliant sound.

A bass speaker as well as two medium and treble speakers, each in their own casing, create an outstanding sound experience.



# OVERVIEW

## The hi-fi system controls

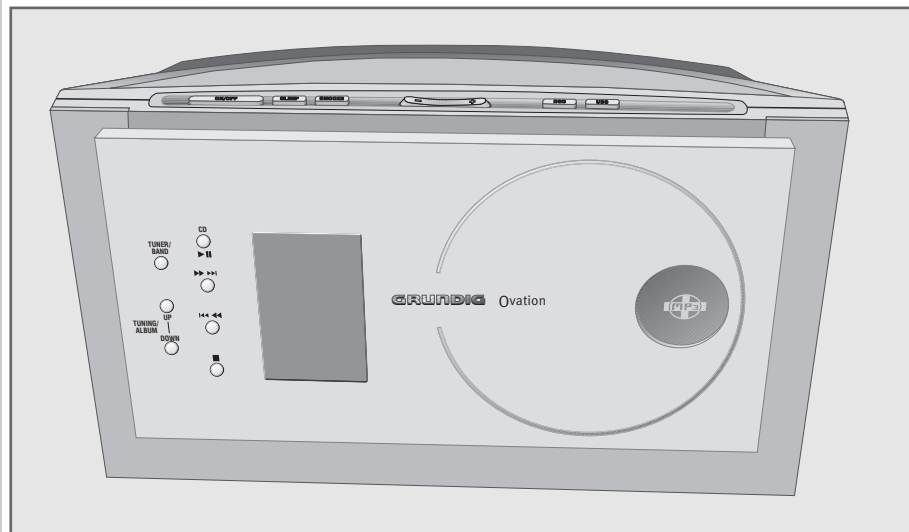

### Controls on the front

#### Tuner mode

##### TUNER/BAND

Switches on the hi-fi system with the input source »TUNER«, selects the input source »TUNER«; selects the waveband »FM« or »MW«.

##### TUNING/ALBUM UP - DOWN

Press and hold down to start the station search; press briefly to change the frequency in small steps.



Select stored radio stations.

#### CD mode

##### Front panel

Fold to the front to open the CD compartment. When the compartment is closed the hi-fi system switches on from standby automatically.

##### CD ► II

Switches the hi-fi system on with the »CD« input source, selects the »CD« input source; activates CD playback and pauses playback.

##### TUNING/ALBUM UP - DOWN

In MP3 mode: select the next or previous album.

# OVERVIEW

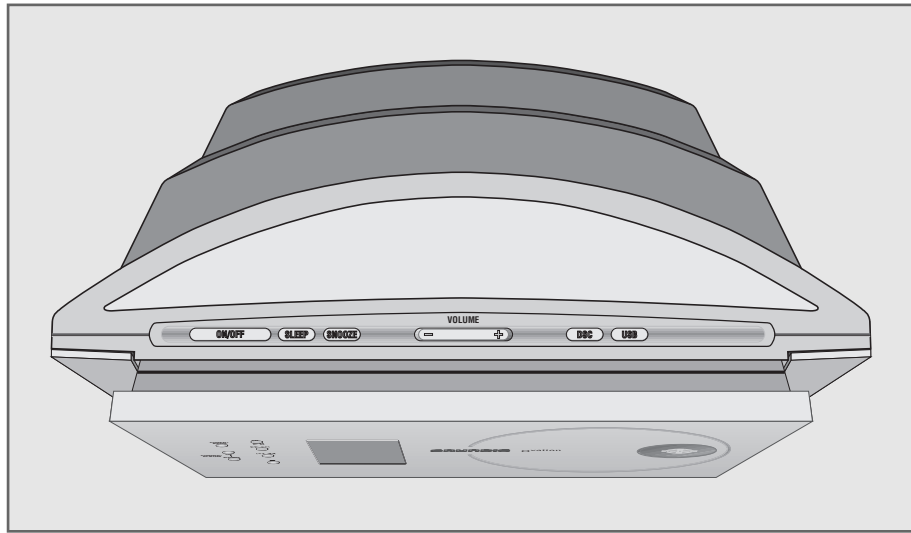

In MP3 and CD-DA mode: pressing briefly selects the next file or the next track; holding down searches for a particular passage.



In MP3 and CD-DA mode: pressing briefly selects the previous file or the previous track; holding down searches backwards for a particular passage.



Ends CD playback;  
pressing twice deletes the track memory for the CD.

## Controls on the top

### General information

#### ON/OFF

Switches the device to and from standby mode. The device is only fully disconnected from the mains after the plug has been pulled out.

#### SLEEP

For setting the sleep timer.

#### SNOOZE

Interrupts the alarm function.

#### - VOLUME +

Adjusts the volume.

# OVERVIEW

---

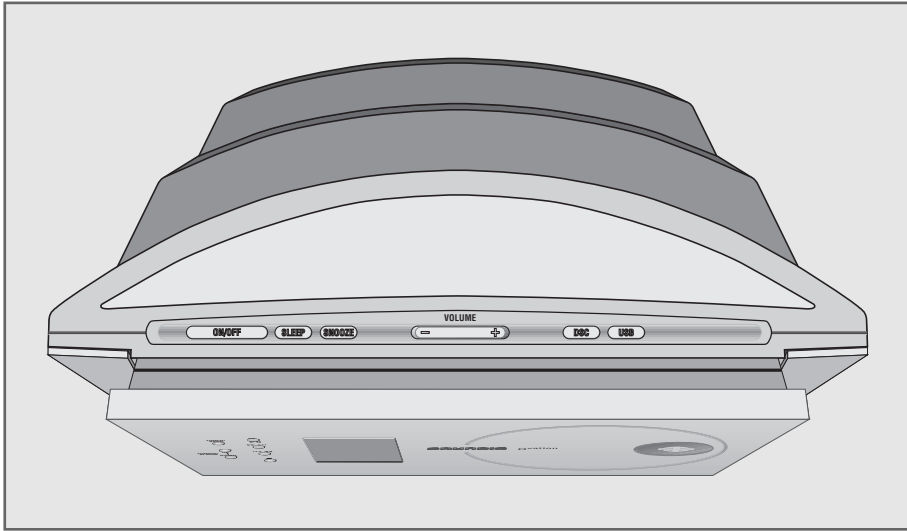

## **DSC**

Selects the sound settings USER, CLASSIC, POP, JAZZ and ROCK; adjusts the equaliser (BASS or TREBLE).

## **UBS**

Switches the Ultra Bass System on and off.

## **AUTO DIMMER**

Sensor. Automatically adjusts the back light of the display to the brightness of the room.

# OVERVIEW

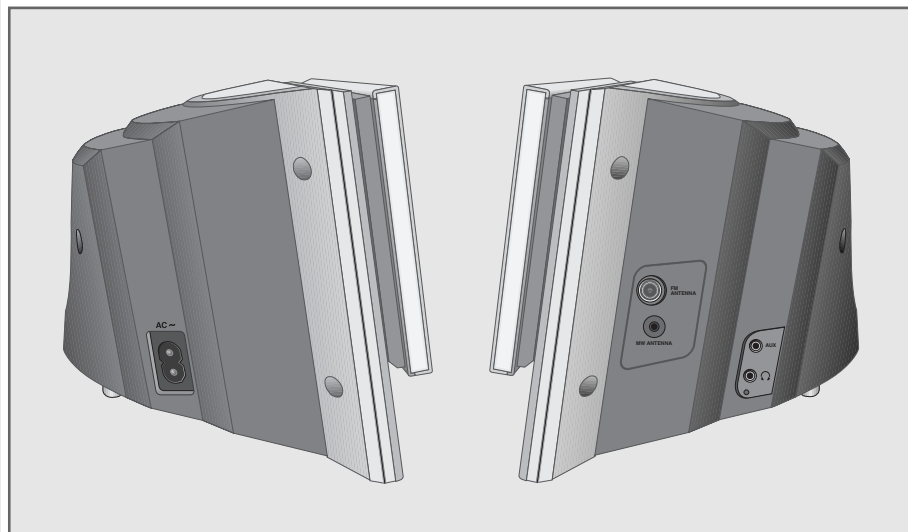

## Controls on the sides

### AC ~

Socket for mains cable (left side of the device). The only way to isolate the hi-fi system from the mains supply is to pull the plug out.

### AUX

Audio signal input for an external device on the right hand side.



Headphone socket for connecting a stereo headphone set with a jack plug (ø 3.5 mm) on the right side of the device.

The speakers of the hi-fi system are automatically switched off.

### FM ANTENNA

Antenna socket for the rooftop antenna or the wire antenna supplied.

### MW ANTENNA

Antenna socket for connecting the MW frame antenna supplied.

## Controls on the bottom

### RESET

Resets the hi-fi system in case of malfunction. Press »RESET« to reset, using an implement such as a paper clip.

# OVERVIEW

## The hi-fi system displays



000:000

In standby mode: displays the time.

In tuner mode: displays the preset station.

In MP3 mode: displays the total number of albums and files, and the elapsed playing time of the current file.

In CD-DA mode: displays the total playing time, and the elapsed playing time of the current track.

000000.00

In standby mode: displays the day of the week.

In tuner mode: displays the wavelength and the frequency or the station name.

In MP3 mode: displays the disc format and the number of the current file.

In CD-DA mode: displays the disc format, the total number of tracks and the number of the current track.

JAZZ 

Displays the selected sound setting, for example »JAZZ«.



The Ultra Bass System is activated.

**ALBUM**

In MP3 mode: displays the total number of albums or the number of an album.

**PM**

Displays the second half of the day in 12-hour format.

**FILE**

In MP3 mode: displays the total number of files or the number of an file.



In tuner mode: flashes when awaiting an RDS time signal; lights up when RDS time synchronisation is complete.



1

In MP3 and CD-DA mode: a file or a track is repeated.



ALL

In MP3 and CD-DA mode: all files or tracks of a CD are repeated.



ALBUM

In MP3 mode: all files on an album are repeated.

**INTRO**

In MP3 and CD-DA mode: the first ten seconds of each file or track are played.



# OVERVIEW



**RANDOM** In MP3 and CD-DA mode: all files or tracks are played back in random order.

**PROG** In tuner mode: a stored radio station is selected or played.  
In MP3 and CD-DA mode: a track memory is created or played back.

**CD** In tuner mode: an FM stereo station is being received.

**KHZ** In tuner mode: in combination with the MW frequency indicator.

**MHZ** In tuner mode: in combination with the FM frequency indicator.

**▶** In MP3 and CD-DA mode: a CD is played back.

**||** In MP3 and CD-DA mode: CD playback is interrupted (pause).

**R-D-S** In tuner mode: an RDS station is being received.

**PTY** In tuner mode: the PTY (station type) function is activated.

**TEXT** In tuner mode: the radio text function is activated.

**NAP** The reminder timer is activated.

**🔔** In timer mode: the signal alarm function is activated.

**🎵** In timer mode: the radio or CD alarm function is activated.

**WEC** In timer mode: the alarm function is deactivated at the weekend.

**🛏** The sleep timer is activated.

# OVERVIEW

## The remote control



### ON/OFF

Switches the hi-fi system to standby mode and from standby mode to the last signal source selected.

### CD ► II

Switches the hi-fi system on with the »CD« input source, selects the »CD« input source; In MP3 and CD-DA mode: starts and pauses CD playback.



In MP3 and CD-DA mode: ends CD playback pressing twice deletes the track memory for the CD.



In tuner mode: selects stored radio stations. In MP3 or CD-DA mode: pressing briefly selects files or tracks forwards or backwards; pressing and holding down searches forwards or backwards for a particular passage.

### DSC

Selects the sound settings USER, CLASSIC, POP, JAZZ and ROCK; adjusts the equaliser (BASS or TREBLE).

### UBS

Switches the Ultra Bass System on and off.



Adjust the volume.

### TUNER/BAND

Switches on the hi-fi system with the input source »TUNER«, selects the input source »TUNER«; selects the waveband »FM« or »MW«.

### TUNING/ALBUM



In tuner mode: holding and pressing down starts the station search; briefly pressing changes the frequency forwards or backwards in steps. In MP3 mode: selects albums forwards or backwards in steps.

### PTY

In tuner mode: calls up the current station type (PTY); selects the station type (PTY) for PTY search.

### COLOR

Selects the colour of the display back light (8 colours).

### BRIGHTNESS

Changes the brightness of the display to one of three levels (bright, medium, off).

# OVERVIEW



## DISPLAY

In tuner mode: switches the display between frequency, station name, station type, radio text and time/day.

In CD-DA mode: switches the display between track number/elapsed playing time, remaining track playing time, total remaining running time and time/day.

In MP3 mode: switches the display between file number/elapsed playing time, file name/ID3 tag information (ticker text) and time/day.



Switches the hi-fi speakers to and from mute mode.

## AUX

Switches the hi-fi system on with the »AUX« input source, selects the »AUX« input source (external device).

## FM MODE

In tuner mode: switches between mono and stereo reception.

## INTRO./REP.



In MP3 and CD-DA mode: plays the introduction to the files or tracks on a CD; repeats a file or track, all files or tracks of a CD or all files of an album.

In stand-by mode: sets the switch-on time and the alarm clock.

## PROG./RAND.



In tuner mode: stores radio stations.

In MP3 and CD-DA mode: saves files or tracks for track memory; plays back files or tracks in random order.

In stand-by mode: for setting the time and day manually.

## SLEEP

For setting the sleep timer.

## NAP

In standby mode: for setting the reminder timer.

## WEC

Interrupts or reactivates the alarm function for the weekend.

## SNOOZE

Interrupts the alarm function for about 5 minutes; interrupts the reminder timer.

# CONNECTION AND PREPARATION

## Connecting the antenna

- 1 Plug the rooftop antenna cable into the »FM ANTENNA« antenna socket on the hi-fi.

### Note:

If no rooftop antenna is available, use the auxiliary antenna supplied. This antenna provides reasonably good reception of local FM (VHF) stations. Do not shorten the auxiliary antenna.

- 2 Plug the wire frame antenna into the »MW ANTENNA« socket on the hi-fi system. Adjust the position of the wire frame antenna until you get the best reception.

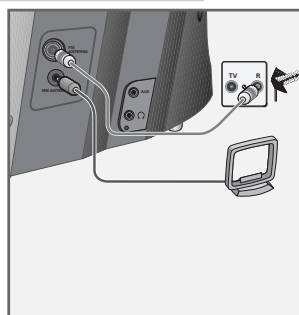

## Connecting an external device

- 1 Connect the audio input sockets of the external device to the »AUX« socket on the right side of the hi-fi system with a stereo jack plug (ø 3,5 mm).

### Note:

Switch the hi-fi system off before you connect external devices.

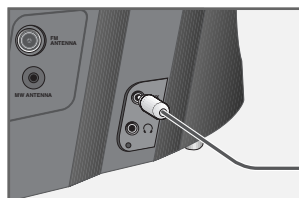

## Connecting the headphones

- 1 Insert the headphone plug (ø 3,5 mm) into the »« socket on the right side of the hi-fi.  
– The loudspeakers of the hi-fi system are switched off.



## Connecting the power cord

### Note:

Check that the mains voltage on the type plate (on the bottom of the hi-fi system) corresponds to your local mains supply. The only way to disconnect the hi-fi system from the mains supply is to pull the plug.

- 1 Plug the mains cable supplied into the »AC ~« socket on the hi-fi system.
- 2 Plug the power cord into the wall socket.

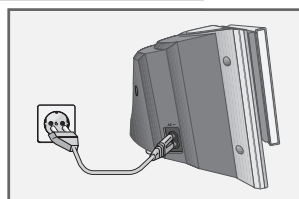

# CONNECTION AND PREPARATION

## Inserting batteries in the remote control

- 1 Open the battery compartment by pushing down its lid.
- 2 When inserting the batteries (2 x 1.5 V, R 6/UM 3/AA), observe the polarity marked on the base of the battery compartment.

### Note:

If your hi-fi system no longer reacts properly to remote control commands, the batteries may be flat. Always remove used batteries. The manufacturer accepts no liability for damage resulting from leaking batteries.

### Environmental note:

Batteries, including those which contain no heavy metal, should not be disposed of with household waste. Please dispose of used batteries in an environmentally responsible manner. Find out about the legal regulations which apply in your area.

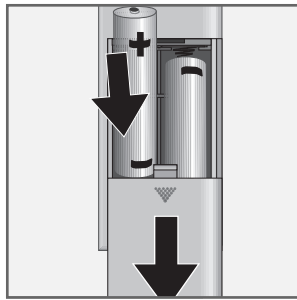

# CONNECTION AND PREPARATION

## Additional information for units sold in the UK.

Units sold in the UK are suitable for operation from a 240V ac, 50Hz mains supply.

The range of multi-system receivers is built to work in most European countries. However, the mains plug and socket system for the UK differs from many European countries.

This appliance has been supplied with a fitted, non-removable, approved converter plug for use in the UK. This converter plug is fitted with a 5A rated fuse.

In case this appliance is supplied with a moulded 2-pin Euro plug only, which is unsuitable for UK operation, this must be cut off and immediately disposed of. An approved 13A, 3-pin UK plug should then be fitted by a qualified electrician.

### Note:

The severed Euro plug must be destroyed to avoid a possible shock hazard should it be inserted into a socket elsewhere.

If a non-rewireable 3-pin plug or a rewireable 13A (BS1363) 3-pin plug is used, it must be fitted with a 5A ASTA or BSI approved BS1362 fuse. If any other type of plug is used it must be protected by a 5A fuse either in the plug, or at the distribution board. If this type of plug becomes defective, ensure that the fuse is removed before disposal, to eliminate potential shock hazard.

If it is necessary to change the fuse in the non-rewireable plug, the correct type and rating (5A ASTA or BSI approved BS1362) must be used and the fuse cover must be refitted. If the fuse cover is lost or damaged, the lead and plug must not be used until a replacement is obtained. Replacement fuse covers should be obtained from your dealer.

### Important:

The wires in the mains lead are colour coded in accordance with the following code:

BLUE – NEUTRAL

BROWN – LIVE

As the colours of the wires in the mains lead of your appliance may not correspond with the coloured marking identifying terminals in your plug, proceed as follows:

Connect the BLUE coloured wire to plug terminal marked with the letter "N" or coloured black.

Connect the BROWN coloured wire to the plug terminal marked with the letter "L" or coloured red.

In no circumstance must any of the wires be connected to the terminal marked with the letter "E", earth symbol "⏏", coloured green, or green & yellow.

Replacement mains lead sets can be obtained from your local dealer, or by contacting Grundig Consumer Relations (01788 570088)

Moulded 3-pin lead set, suitable for UK use:

Ref: Leadset UK 8290-991-224

Moulded 2-pin Euro lead set, not suitable for UK use:

Ref: Leadset Euro 8290-991-316

# SETTINGS

## Setting the time

A demo programme starts when you connect the hi-fi system to the mains for the first time. To end the demo programme switch the hi-fi system to stand-by mode by pressing »ON/OFF« briefly. Now the time and day displays will flash, indicating that they need to be set. The following settings may only be performed in standby mode.

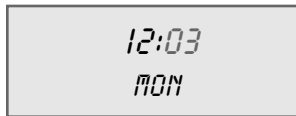
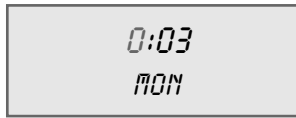

- 1 To set the 12-hour format, briefly press »**PROG./RAND./**⊙«. – Display: briefly »12HR«, then the current time, for example »**PM MON 12:02**« (»**PM**« for the second half of the day).
- 2 To set the 24-hour format, press »**PROG./RAND./**⊙« again. – Display: briefly »24HR«, then the current time, for example »**MON 0:03**«.
- 3 To set the time, press and hold down »**PROG./RAND./**⊙«. – Display: the hours flash.
- 4 Set the hours using »**^ TUNING/ALBUM v**« and press »**PROG./RAND./**⊙« to confirm. – Display: the minutes flash.
- 5 Set the minutes using »**^ TUNING/ALBUM v**« and press »**PROG./RAND./**⊙« to confirm. – Display: the day of the week flashes.
- 6 Set the day of the week using »**^ TUNING/ALBUM v**« and press »**PROG./RAND./**⊙« to confirm. – Display: »**CT MON**« flashes.
- 7 Set the RDS time synchronisation with »**^ TUNING/ALBUM v**« and confirm with »**PROG./RAND./**⊙«.

### Notes:

You must reset the time after a power failure or when the mains plug is pulled out.

Some RDS stations transmit an RDS time signal. If the selected RDS programme transmits this time information, the time on the system is automatically updated. This takes about five minutes.

# SETTINGS

## Setting and storing radio stations

### Automatic station search

After the hi-fi system has been connected to the mains for the first time, the device in tuner mode searches for the 40 stations with the best reception and stores them.

- 1 After connection, switch on the hi-fi system by pressing »**TUNER/BAND**«.   
– Display: »FM«, the frequency in rapid run-through and »**PROG**«.   
– The search has started. After the search has finished, you will hear the station stored at preset position 01.

#### Notes:

The automatic station search can be interrupted by briefly pressing »■«.

The automatic station search can be repeated any time by pressing and holding down »**PROG./RAND.**» until the frequency display switches to rapid run-through. The stations stored previously will be deleted.

### Automatic station search

- 1 Switch on the hi-fi system by pressing »**TUNER/BAND**«.   
– Display: »**TUNER**«, then the wave band and frequency or station name.
- 2 Press »**TUNER/BAND**« to select the frequency band (FM or MW).   
– Display: »FM« or »MW«.
- 3 Activate the station search by pressing »**TUNING/ALBUM**« until the frequency display changes to rapid run-through.   
– The search stops when a station is found.

### Manual station search

- 1 To move the frequency forward in steps, briefly press »**TUNING/ALBUM**« several times.   
– The frequency changes in 50 kHz steps (FM) or 9 kHz steps (MW).



02 MHz  
FM 97.55



16  
TUNER



16 MHz  
ENERGY



FM 87.65 MHz



# SETTINGS

## Storing stations on station positions

- 1 Press »TUNER/BAND« to select the frequency band (FM or MW).
- 2 Press »^ TUNING/ALBUM v« to select the station you want to store.
- 3 Press »PROG./RAND./⊙« to activate the memory function.  
– Display: both the station position »P01« and »PROG« flash.
- 4 Select desired station position with »|« or »|«.

### Note:

If stations are already stored on the preset positions, they are overwritten when new stations are stored.

- 5 Press »PROG./RAND./⊙« again to store the station.  
– Display: »PROG« and, for example, »P02«.
- 6 To store more stations, repeat steps 2 to 5.

### Note:

If the hi-fi is disconnected from the mains for a long time, all the preset stations are deleted.

## Reset

In case of malfunction you can reset the hi-fi system.

- 1 With the device on, press the »RESET« button on the bottom of the hi-fi system using an implement such as a paper clip.



# GENERAL FUNCTIONS

## Switching the hi-fi system on and off

- 1 Switch the hi-fi system on from standby mode by pressing **»ON/OFF«**.  
– The last input source used is automatically selected.

### Note:

The following buttons on the hi-fi or the remote control can also be used to switch on the system:

- »**TUNER/BAND**« – tuner mode; »**CD ► II**« – CD mode;
- »**AUX**« – External device mode.

- 2 Press **»ON/OFF«** to switch the hi-fi system to stand-by.  
– Display: »*GOOD BYE*« briefly, then the current time and day of the week.

### Note:

The only way to disconnect the hi-fi system from the mains supply is to pull the plug.



12:24  
GOOD BYE

## Adjusting the brightness of the display

- 1 Change the overall brightness of the display back light using **»BRIGHTNESS«** on the remote control in three levels (bright, medium, off).  
– Auto dimmer adapts the brightness of the display automatically to the brightness of the surroundings.

## Changing the colour of the display lighting

- 1 Change the colour of the display back light by pressing **»COLOR«** on the remote control. There are eight options.

## Selecting the input source

- 1 Select the input source by pressing **»TUNER/BAND«**, **»CD ► II«** or **»AUX«**.  
– Display: »*TUNER*«, »*CD*« or »*AUX*«.



CD

## Adjusting the volume

- 1 Adjust the volume with **»- VOLUME +«**.  
– Display: briefly »*VOL*« (»*MUTE*«, »*I*« to »*39*«, and above this »*MIX*«).

## Muting

With this function you can switch the hi-fi speakers to and from mute mode.









MUTE

- 1 Press **»M«** on the remote control to switch the sound on and off.  
– Display: »*MUTE*« when mute is on.

# GENERAL FUNCTIONS

## Selecting sound effects

You can select from the sound settings USER, CLASSIC, POP, JAZZ and ROCK. The basic setting is USER.

- 1 Select the sound setting by pressing »DSC«.   
– Display: »USER «, »CLASSIC «, »POP «, »JAZZ   
 « or »ROCK  «.



## Setting the equaliser

The USER sound setting allows you to make your own personal equaliser settings.

- 1 When the device is on, press »DSC« until »USER « appears in the display.
- 2 Press »DSC« again for approximately 2 seconds.   
– Display: »BASS 0«.
- 3 Press »DSC« to choose the setting (BASS or TREBLE).   
– Display: »BASS 0« or »TRE 0«.

### Note:

If you do not press any button within five seconds, the hi-fi system will automatically quit this mode.

- 4 Set the values by pressing »- VOLUME +« (maximum »+5«  
minimum »-5«).   
– The equaliser display disappears after 5 seconds.



## Switching the Ultra Bass System on and off

- 1 Press »UBS« to switch the Ultra Bass System on and off.   
– Display: »UBS «.



## Switching the display

In Tuner and CD mode you can switch the display to show the time and day.

- 1 Press »DISPLAY« repeatedly on the remote control until time and day appear in the display.

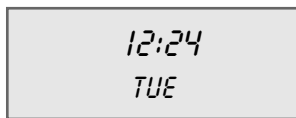

# TUNER MODE

## Selecting the Tuner input source

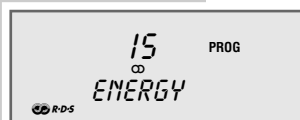

- 1 Press »**TUNER/BAND**« to select the input source.
  - The most recently selected station is activated (Last Station Memory).
  - Display: e.g. »FM 100.50« or »ENERGY«.

## Selecting a preset position



- 1 Press »**TUNER/BAND**« to select the frequency band (FM or MW).
- 2 Select the preset position in steps by pressing »|◀◀« or »▶▶| «.
  - Display: »**PROG**« and, for example, »P02« and the frequency or the station name.

## Stereo/mono reception

When the hi-fi system receives FM stereo stations, »**CD**« appears in the display. If the signal from the FM stereo station is weak, you can improve the sound quality by switching to mono reception.

- 1 Press »**FM MODE**« on the remote control to switch to mono reception.
  - Display: »**CD**« disappears.
- 2 To switch back to FM stereo, press »**FM MODE**« on the remote control.
  - Display: »**CD**«.

### Note:

If the hi-fi is set to stereo reception and is receiving a mono signal, the »**CD**« display flashes.



## Automatic station search

By starting the automatic station search, you can delete all the existing preset stations and replace them with new stations at the same time.



- 1 Start the automatic search in tuner mode by pressing and holding down »**PROG./RAND./**◉«.
  - After the search has finished, you will hear the station stored at preset position 01.

### Note:

The automatic station search can be interrupted by briefly pressing »■«.

# TUNER MODE

## RDS station service



RDS (Radio Data System) is an information system which is transmitted additionally by most FM stations.

When the hi-fi system is receiving an RDS station, the station name, for example »FANTASY«, and » R-D-S« appear in the display.

### Note:



It may take some time before all the RDS information is available.

## Searching for RDS stations

- 1 To search for an RDS station, press » **TUNING/ALBUM** « repeatedly until » R-D-S« appears in the display indicating that an RDS station is being received.
  - After a short time the station name appears if the reception strength is sufficient.

## RDS time synchronisation

Some RDS stations transmit an RDS time signal. If reception is good, this time information will update the time if you have selected the »*ET ON*« option.

Time synchronisation can take several minutes, and even with good reception the accuracy depends on the time signal being transmitted. The automatic time setting is always activated when the hi-fi system is switched from standby mode into tuner mode and receives a suitable RDS station (when the system is waiting for an RDS time signal, »« flashes. »« stays lit once RDS time synchronisation is complete).

## Calling up RDS information

When an RDS station is being received, the frequency is displayed briefly and then the station name appears continuously.

- 1 Press »**DISPLAY**« on the remote control.
  - The station type appears in the display (PTY).
- 2 Press »**DISPLAY**« on the remote control again.
  - The radio text (TEXT) appears in the display as ticker text.
- 3 Press »**DISPLAY**« on the remote control again.
  - The current time and day of the week appear in the display.
- 4 Press »**DISPLAY**« on the remote control again.
  - The wavelength and the frequency appear in the display.
- 5 Press »**DISPLAY**« on the remote control one last time.
  - The station name is displayed continuously once again.



# TUNER MODE



## Station types (PTY)

- 1 To call up the current station type, press »PTY« on the remote control.
  - Display: the current station type, e.g. »NEWS«, and »PTY«.
  - If no station type code is transmitted, »NO PTY« appears in the display.
- 2 Press »PTY« repeatedly on the remote control to select another station type.
- 3 Press »^ TUNING/ALBUM v« to start the PTY search.
  - Display: »FM«, the frequency in rapid run-through, and »PTY« flashes.
  - The search stops once a station of the desired station type is found, and the selected station type, for example »POP M«, and the current time appear in the display.
- 4 Press »PTY« briefly to stop the search.

# CD MODE



The hi-fi system is suitable for music CDs bearing the logo shown here (CD-DA), and for CD-Rs and CD-RWs with audio data or MP3 formats.

In MP3 mode, the terms "album" and "file" are very important. "Album" corresponds to a folder on a PC, "file" to a file on a PC or a CD-DA track. An MP3 CD may not contain more than 200 albums and 500 files in total.

The hi-fi system sorts the albums, or the files on an album, by name into alphabetical order. If you wish to order them differently, change the name of the file or album and put a number before the name.

When burning CD-R and CD-RWs with audio files, various problems may arise which could lead to interference in playback. This can be caused by faulty software or hardware settings or by the CD being used. Should such problems arise, contact the customer services of your CD burner or software manufacturer or look for relevant information, for example on the Internet. When you are making audio CDs, observe all legal guidelines and ensure that the copyright of third parties is not infringed.

Always keep the CD compartment closed to prevent dust from collecting on the laser optics. Do not attach adhesive labels to CDs. Keep the surfaces of CDs clean. You can play standard 12 cm CDs as well as 8 cm CDs on your device. An adapter is not necessary.

## Selecting the CD input source

*NO DISC*

- 1 Press »**CD** ► **II**« to select CD as the input source.
  - If there is no CD in the compartment, the message »*NO DISC*« appears in the display.
  - In MP3 mode if there is a CD already inserted: the device scans the content of the CD. Playback starts automatically with the first file of the first album.
  - In CD-DA mode if a CD is already inserted: the device scans the content of the CD. Playback starts automatically with the first track.

# CD MODE

## Inserting a CD



OPEN

- 1 Open the CD tray on the hi-fi by lifting up the front panel.  
– Display: »OPEN«.
- 2 Place the CD in the compartment with the printed side facing outwards.
- 3 Close the CD compartment and return the front panel to its original position.  
– Display: »CD READ« flashes.  
– In MP3 mode: the hi-fi system scans the contents of the CD. The display shows the total number of albums and files, and the format »MP3 DISC«.  
– In CD-DA mode: the hi-fi system scans the contents of the CD. The display shows the total playing time, the total number of tracks and the format »CD«.



ALBUM FILE  
009 087  
MP3 DISC



1:15  
001 DISC



3:26  
001 DISC

## Playing back a CD

- 1 Press »CD ► II« to start playback.  
– Playback always starts with the first file of the first album (MP3) or with the first track (CD-DA).  
– Display in MP3 mode: the number of the current file, followed by the file name and the elapsed playing time of the file.  
– Display in CD-DA mode: »►«, the number of the current track, the elapsed playing time of the track.
- 2 Use »CD ► II« to switch to playback pause.  
– Display: »II«, the elapsed playing time of the file or track flashes.
- 3 Press »CD ► II« to resume playback.
- 4 End playback with »■« (press twice).

## Pausing and resuming playback

- 1 Interrupt playback by pressing »■« once.
- 2 Press »►► II« to resume playback at the beginning of the same file or track.

### Note:

Playback also resumes at beginning of the same file or track if you switch from CD mode to another input source and then back to CD mode.

## Repeating the current file or track

- 1 Press »|◀◀« briefly during playback.  
– The file or track is repeated from the beginning.



# CD MODE

## Selecting another file or track

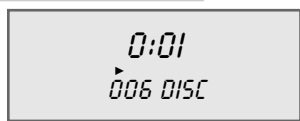

0:01  
▶  
006 DISC

- 1 During playback, keep pressing »|◀◀◀ or »▶▶▶ ◀ until you see the number of the file or track you want in the display.  
– Playback of the selected file or track starts automatically.

**Note:**

You can also select files/tracks in stop mode.

## Searching for a passage within a file or track

- 1 During playback, press »|◀◀◀ or »▶▶▶ ◀ and hold it down until you find the passage you want to hear.  
– If »|◀◀◀ or »▶▶▶ ◀ are released, playback starts.

**Note:**

During the search the volume is reduced.

## Selecting albums and files (MP3 only)

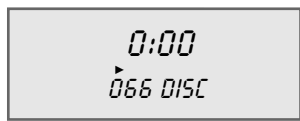

0:00  
▶  
006 DISC

- 1 During playback, select the desired album by pressing »^ TUNING/ALBUM v◀.
- 2 Select the file you want by pressing »|◀◀◀ or »▶▶▶ ◀.  
– Playback of the selected file starts automatically after a short time.

**Notes:**

You can also select albums and files in the stop position.

However, an album can only be counted and selected if it actually contains MP3 files.

## Calling up track information (MP3 only)

You can call up track information (ID3 tag and ticker text) with this function.



▶  
TITLE WHISKEY IN THE JAR

- 1 During playback the display switches to displaying the file name.
- 2 Press »DISPLAY◀.  
– You are provided with information on the track, the artist and the album if such information is stored on the CD.
- 3 To return to the file name display, press »DISPLAY◀ repeatedly until the file name is displayed again.

# CD MODE

## Repeating a file or a title (Repeat One)

- 1 Press »CD ► II« to start playback.
- 2 Press »|◀◀« or »▶▶|« to select the file or track.
- 3 Select the repeat function by pressing »INTRO/REP./⏮« until »🎵1« appears in the display.  
– The file or track is played back repeatedly.
- 4 To quit the function, press »INTRO/REP./⏮« repeatedly until the repeat symbol »🎵« disappears from the display.



🎵 1:15  
001 DISC

## Repeating all the files on an album (MP3 only)

- 1 Press »CD ► II« to start playback.
- 2 Select the repeat function by pressing »INTRO/REP./⏮« repeatedly until the display shows: »🎵ALBUM«.  
– All the files on the current album are played back repeatedly.
- 3 To quit the function, press »INTRO/REP./⏮« repeatedly until the repeat symbol »🎵« disappears from the display.



🎵ALBUM 2:55  
021 DISC

## Repeating all files or tracks (Repeat All)

- 1 Press »CD ► II« to start playback.
- 2 Select the repeat function by pressing »INTRO/REP./⏮« until »🎵ALL« appears in the display.  
– The CD is repeated from the beginning.
- 3 To quit the function, press »INTRO/REP./⏮« repeatedly until the repeat symbol »🎵« disappears from the display.



🎵ALL 3:24  
045 DISC

### Note:

If a track memory is stored (see below), all the tracks of the CD inserted are repeated when the Repeat All function is called up.

# CD MODE

## Playing back files or tracks in random order (Random)

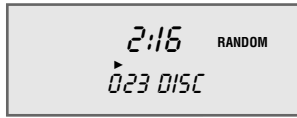

- 1 Press »**CD** ► **II**« to start playback.
- 2 Press »**PROG./RAND./**◀« to select the function.
  - Display: »**RANDOM**«.
  - The files or tracks on the CD are played back in random order.
- 3 To end this function, press »**PROG./RAND./**◀«.
  - Display: »**RANDOM**« disappears.
  - The tracks are played back in numerical order.

## Playing the introductions of files or tracks (Intro)



- 1 Press »**INTRO/REP./**◀« when in stop mode.
  - Display: »**INTRO**«.
  - Playback starts automatically. The first ten seconds of each file or track are played.
- 2 To quit the function, press »**INTRO/REP./**◀« until »**INTRO**« disappears from the display.
  - The current track and subsequent tracks are played to the end.

# CD MODE

## Creating a track memory

You can create a track memory of up to 60 files on different albums (MP3) or up to 60 tracks (CD-DA) for the current CD in any order you choose and then play them back in that sequence. A file or track may be stored more than once. Programming is only possible in stop mode.

### Selecting and storing files (MP3 only)

- 1 Press »**PROG./RAND./**⊙« to call up the function.  
– Display: the album and file display »000 000«, »**PROG**« blinks.
- 2 Select the album with »**^ TUNING/ALBUM** **v**«, select the file with »|« or »|« and press »**PROG./RAND./**⊙« to store.  
– Display: the album and file display »000 000« appears again, »**PROG**« blinks.
- 3 To store more files, repeat step 2.

### Selecting and storing tracks (CD-DA only)

- 1 Press »**PROG./RAND./**⊙« to call up the function.  
– Display: track display »00« and »**P-01**«, »**PROG**« flashes.
- 2 Select a track with »|« or »|« and press »**PROG./RANDOM/TIME**« to save it.  
– Display: track display »00« and »**P-02**«, »**PROG**« flashes.
- 3 To store more tracks, repeat step 2.

### Playing back a track memory

- 1 Start the track memory by pressing »**CD ▶ II**«.  
– Display: »**PROG**«.  
– Playback begins with the first programmed file or track.
- 2 Press »**■**« to end playback.  
– Display: »**PROG**« flashes.
- 3 To play the track memory again, press »**CD ▶ II**«.

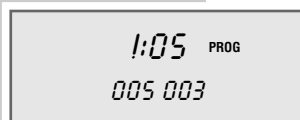
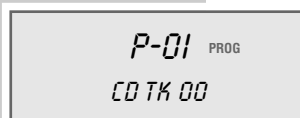
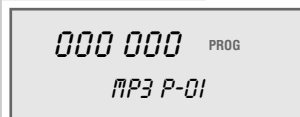

# CD MODE

---

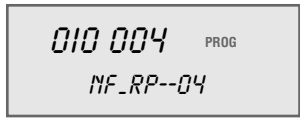

010 004    PROG  
MF\_RP--04

## Checking the track memory

- 1 Press »**PROG./RAND./**☺« repeatedly when in stop mode.  
– The sequence of the stored files or tracks is displayed.

## Adding files or tracks

- 1 In the stop position, select the file or track with »|◀◀« or »▶▶| ◀« and press »**PROG./RAND./**☺« to store.

## Deleting the track memory

- 1 Open the CD compartment on the hi-fi  
or  
press »■◀« when the CD is in the Stop position (»**PROG**◀ mode).

# TIMER MODE

Your hi-fi system has three timer modes:

- The switch-on timer, which switches the hi-fi system on at the set time and wakes you with an alarm or music.
- The reminder timer, reminding you by sounding the signal tone at a preset time.
- The sleep timer, which switches the hi-fi system off at a preset time.

## Switch-on timer

### Setting the switch-on timer

The time must be set on the hi-fi system. When this setting is being made, if no button is pushed for more than 10 seconds, the hi-fi system will end the process automatically. You then have to start again.

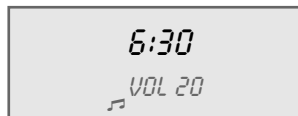
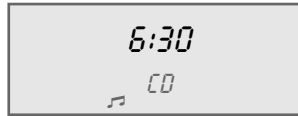
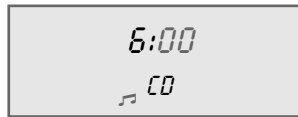
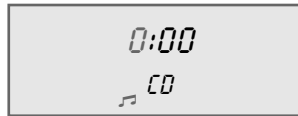

- 1 With the device switched off, press and hold down »**INTRO/REP./**⏪«. – Display: »**♪**« and the hour display flashes.
- 2 Set the hours for switching on using »**^ TUNING/ALBUM** v«..
- 3 »**INTRO/REP./**⏪«. – Display: »**♪**« and the minutes display flashes.
- 4 Set the minutes for switching on using »**^ TUNING/ALBUM** v«..
- 5 »**INTRO/REP./**⏪«. – Display: »**BUZZER** ⏪«, »**TUNER** **♪**« or »**CD** **♪**« flashes.
- 6 Set the input source (signal, radio station or CD) using »**^ TUNING/ALBUM** v«..

#### Notes:

If you select CD, make sure that a CD has been inserted.

If you select tuner, select the radio station with »**⏪**« or »**⏩**«.

- 7 »**INTRO/REP./**⏪«..
- 8 Set the volume using »- **VOLUME** +«..

# TIMER MODE



- 9 Press »**INTRO/REP.**» to finish the settings.
  - Display: »**⏮**« or »**🎵**«, the day and time.
  - The hi-fi system switches on at the set time with the selected signal source (maximum alarm duration 90 minutes).

## Note:

The volume of the alarm types signal, radio station and CD increases continually from zero onwards until an individually set maximum volume is reached.

## Interrupting the alarm

- 1 During the alarm, press »**SNOOZE**« on the remote control.
  - The alarm signal (signal tone, radio station or CD) stops.
  - The alarm goes off again at 5-minute intervals (alarm duration - 90 minutes).

## Canceling the alarm for the day

- 1 Switch the hi-fi system off by pressing »**ON/OFF**« when the alarm is sounding.
  - The switch-on timer remains activated for the next day.

## Switching off alarm for the weekend

You can switch off the alarm function over the weekend. The entered alarm times are saved.



- 1 Switch off the alarm function with »**WEC**«.
  - Display: »**WEC**«.
- 2 Press »**WEC**« to reactivate the alarm function.
  - Display: »**WEC**« disappears.

## Activating and deactivating switch-on timer

- 1 To deactivate the switch-on timer, press »**INTRO/REP.**» briefly in standby mode.
  - Display: »**⏮**« or »**🎵**« disappear.
  - The switch-on timer is deactivated, the set alarm time is stored.
- 2 To activate the switch-on timer, press »**INTRO/REP.**» briefly in standby mode.
  - Display: »**⏮**« or »**🎵**«.

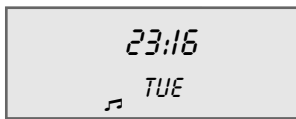

# TIMER MODE

## Reminder timer

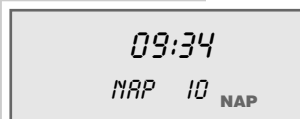

- 1 Press »**NAP**« to call up the function.  
– Display: »*NAP 10*« (minimum time setting), »**NAP**« flashes.
- 2 Enter the reminder time (in 10 minute intervals from 10 to 120 minutes) with »**NAP**«.  
– Display: »**NAP**«.  
– After the set time has expired, a signal tone sounds (for max. 90 minutes).  
– The display shows the currently remaining time, for example »*NAP 25*«, if you press »**NAP**« briefly.
- 3 Switch off the signal tone with »**ON/OFF**«;

or

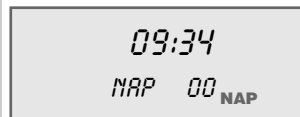

interrupt the reminder timer early by setting the timer to »*NAP 00*« with »**NAP**«.

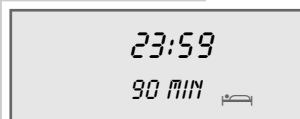

## Sleep timer

### Setting the sleep timer



- 1 Switch on the hi-fi system by pressing »**ON/OFF**« and select the input source you require.
- 2 Press »**SLEEP**« to call up the function.  
– Display: »*90 MIN*«, »« flashes.
- 3 Enter the required switch-off time (in 10 minute intervals from 90 to 10 minutes) by pressing »**SLEEP**«.  
– Display: »«.  
– The hi-fi system switches off after the selected time has elapsed.



### Ending the sleep timer prematurely

- 1 To deactivate the sleep timer, press »**ON/OFF**« to switch off the hi-fi;

or

keep pressing »**SLEEP**« until »*00 MIN*« appears in the display and »« flashes.  
– The hi-fi system remains switched on.

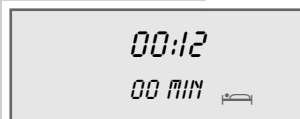



# INFORMATION

## Cleaning the CD unit

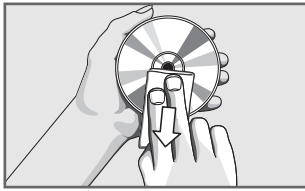

If the device is unable to scan CDs perfectly, use a standard, commercially available cleaning CD to clean the laser optics. Other cleaning methods may damage the laser optics.

To clean CDs use a lint-free cloth and wipe them in a straight line from the centre of the disc outwards. Do not use cleaning fluid for vinyl records or other solvents or scouring agents.



## Technical data

This device is noise-suppressed according to the applicable EU directives.

This product fulfils the European directives 89/336/EEC, 73/23/EEC and 93/68/EEC.

This device conforms to the safety regulation DIN EN 60065 (VDE 0860) and thereby the international safety regulation IEC 60065.

Do not open the hi-fi casing under any circumstances. No warranty claims are accepted for damage caused by incorrect handling.

### System

#### Power supply:

Operating voltage: 230 V~

Mains frequency: 50/60 Hz

Max. power consumption: 35 W

Power consumption in standby:  $\leq 3.5$  W

### Amplifier unit

#### Output:

Sine wave power: 2 x 3 W, 1 x 6 W

Music signal power: 2 x 5 W, 1 x 10 W

### Receiver unit

#### Reception range:

FM 87.5 ... 108.0 MHz

MW 522 ... 1620 kHz

### CD unit

#### Frequency response:

20 Hz ... 20 kHz

#### Noise-voltage ratio:

(wtl.)  $\geq 70$  dB

### MP3 features

#### Albums and files:

Max. 512 albums and files per CD

#### File system/file management:

ISO 9660 Level 1 compatible

### Dimensions and weight

Device dimensions:

W x H x D 310 x 180 x 190 mm

Device weight: 3.3 kg

## Environmental note

This product has been made from high-quality parts and materials which can be re-used and recycled.

Therefore, do not throw the product away with normal household waste at the end of its life. Take it to a collection point for recycling electrical and electronic devices. This is indicated by this symbol on the product, in the operating manual and on the packaging.

Please find out about collection points operated by your local authority.

Help protect the environment by recycling used products.



# INFORMATION

CLASS 1  
LASER PRODUCT



## General information on laser devices

Your system is a CLASS 1 LASER PRODUCT. This means that the laser is designed in such a way as to ensure that the maximum permissible emission value cannot be exceeded under any circumstances.

### Caution:

If operating devices or methods other than those specified here are employed, it may lead to dangerous exposure to emissions.

This device emits laser radiation. Because of the danger of eye injuries, the unit may only be opened or serviced by trained personnel.

If settings other than those specified here are employed or other procedures are carried out, this may lead to dangerous radiation exposure.

## Troubleshooting

Not every kind of sound interference is caused by a defect in your hi-fi system. Defects can also be caused by leads having been accidentally pulled out, damaged CDs and worn out batteries in the remote control. If the following measures do not do not rectify the problem, consult an authorised dealer.

Fault	Possible cause/remedy
No sound.	The volume setting is too low – increase the volume. The headphones are plugged in – disconnect the headphones. The power cord is incorrectly connected. Connect it properly. Mute is activated, deactivate Mute.
The hi-fi system does not react when the buttons are pressed.	Static electrical discharge. Switch off the hi-fi system, disconnect the power cable and plug it in again after a few seconds or press »RESET«.
The remote control does not work.	The batteries are flat. Replace the batteries. The remote control is out of range of the stereo.
Poor radio reception.	Weak antenna signal, check the antenna. Weak FM-stereo signal, switch to Mono. Interference from electrical devices such as televisions, video recorders, computers, neon lamps, thermostats or motors. Keep the hi-fi system away from such devices.
Tracks on a CD are skipped.	The CD is damaged or dirty – replace the CD or clean it. The PROGRAM (track memory) or RANDOM functions are active. Deactivate the functions.
CD-Rs or CD-RWs are not played back, or are played back incorrectly.	Faulty software or hardware settings during burning or the CD itself. Check the components of your CD burner/software or change the CD being used.

