

AQUALISA

# Quartz®

Thermo

Concealed shower valve with adjustable head



# Shower systems

# Components



Quartz Thermo built-in  
shower valve with  
adjustable head  
**QZ3111**

# Important information

## Introduction

The Quartz Thermo is designed for both built-in and concealed panel mount installation and is supplied complete with adjustable height head. Quartz Thermo provides close temperature stability and fail safe protection when installed on approved gravity or pumped systems and balanced high pressure systems.

A cold inlet flow regulator is provided for use with instantaneous (multipoint) gas water heater and combination boiler applications.

If you have any questions at any stage during installation please contact the Aqualisa customer helpline on 01959 560010.

## Safety information

This product must be installed by a competent person in accordance with all relevant current Water Supply Regulations.

Quartz Thermo is designed for domestic use only.

## Flushing

Some modern fluxes can be extremely corrosive and, if left in contact, will attack the working parts of this unit. All soldering must be completed and the pipe work thoroughly flushed out in accordance with current Water Supply Regulations prior to connection of the product.

## Connections

The Quartz Thermo valve incorporates 'push fit' type connections for use with 15mm British Standard copper tube. Tube should be cut using a rotary type cutter and lubricated using a silicone based lubricant or petroleum jelly (Vaseline or similar) prior to insertion into the fitting. Supply lines must be flushed clear of any debris before installation of the unit.

If plastic pipe is to be used, the tube insert must not increase the tube diameter or extend the cut off length by more than 2mm.

**THESE FITTINGS ARE NOT SUITABLE FOR STAINLESS STEEL TUBE**

## Isolating valves

Suitable isolation valves such as gate valves must be fitted to both supplies in accordance with the current Water Supply Regulations and our terms of warranty.

Due to their restrictive characteristics, stopcocks and ball type valves that reduce the pipe bore size must not be used on gravity or pumped installations.

## Filters

To ensure ongoing optimum performance the internal control mechanism 'cartridge' is protected by a two-part filter system. Debris accumulation may result in reduced flow from the shower head and noisy operation.

As this condition is not covered by our standard warranty terms, it is suggested that the cartridge be removed and the filters checked by a competent person. In the event of any difficulties please contact the Aqualisa customer helpline for assistance.



## Siting

For optimum performance, with gravity fed systems, the distance between the bottom of the storage cistern and the shower head should not be less than 1m (when using an adjustable height shower kit). If using a fixed head, the highest point of the pipe work must be not less than 1m below the underside of the cistern. Please refer to the system layouts on page 15

# Important information

## Pump installation

**UNDER NO CIRCUMSTANCES MUST A PUMP BE FITTED DIRECTLY TO THE WATER MAIN.**

A pump must only be used to boost the pressure from tank-fed supplies. A typical layout is shown on the reverse of this guide.

## Stored water capacities

The minimum capacity of the cold storage cistern should not be less than 225 litres (50 gallons). The capacity of the hot cylinder must be capable of meeting the anticipated demand.

## Pressures

The Quartz Thermo shower valve is designed to control static pressure up to 10 bar. Where pressures are likely to exceed 10 bar, a pressure reducing valve (PRV) must be fitted into the incoming mains supply. A setting of 3 bar is recommended. It should be noted that daytime pressures approaching 8 bar can rise above the stated maximum overnight.

Quartz Thermo is not suitable for mixed supply systems e.g. gravity hot and mains cold.

A suitable PRV is available from Aqualisa.

## Gravity fed hot and cold supplies

Services must be installed according to good plumbing practice having regard to pipe sizing, long pipe runs and low-head situations.

The cold supply for the valve assembly must be taken directly from the cold storage system. The hot supply may be taken from the vent/draw off pipe of the hot water cylinder at a point below the cylinder connection or alternatively from the underside of the horizontal draw off.

Rising pipe work must not be connected into the horizontal draw-off from the cylinder or to any point in the vent/draw off pipe above the cylinder connection.

**CYLINDER TEMPERATURE IN EXCESS OF 65°C MAY RESULT IN POOR SHOWER PERFORMANCE.**

To minimise pressure loss we recommend that the hot and cold supplies are run in 22mm as close as reasonably possible to the mixing valve before reducing to 15mm.

A typical layout is shown on page 15.

## Combination boiler/multipoint system

The gas water heater must be capable of raising the temperature of the incoming water by 35°C and delivering a flow rate of no less than 9 litres (2 gallons) per minute to the shower valve. This is sufficient to operate one outlet point at a time.

The Aqualisa Thermo cartridge is designed to operate from the mains at a maximum pressure of 10 bar. If the mains pressure exceeds 10 bar a 'drop tight' PRV must be fitted on the supply pipe after the main stopcock.

The cold supply can be taken from the nearest convenient mains supply and the hot supply can be taken from the nearest hot water draw-off point. Account must be taken of the pressure drops that will occur when other draw-off points are used while the shower is in use. Pipe work can generally be run in 15mm.

A typical layout is shown on page 15.

## Balanced high-pressure system

The Aqualisa Thermo cartridge is designed to operate with unvented hot water storage systems up to a maximum pressure of 10 bar. A PRV must be used if either supply exceeds 10 bar. The cold water supply must be drawn from the same mains supply as that to the hot water system (down stream of the cylinder manufacturer's pressure limiting valve, where supplied) and the hot supply from the nearest convenient draw off point. Account must be taken of pressure drops that may occur when other draw-off points are used while the shower is in use. Pipe work can generally be run in 15mm.

A typical layout is shown on page 15.

# Step-by-step instructions



In addition to the guide below it is essential that the written instructions overleaf are read and understood and that you have all the necessary components (shown overleaf) before commencing installation. Failure to install the product in accordance with these instructions may adversely affect the warranty terms and conditions. Do not undertake any part of this installation unless you are competent to do so. Prior to starting ensure that you are familiar with the necessary plumbing regulations required to install the product correctly and safely.



Quartz Thermo is supplied with universal fixings.

1

If installing the product built in to a solid wall, chase out a suitable recess in the wall to receive the valve and pipe work. If installing the valve in a concealed panel mounted situation, in most cases it will be necessary to first install a suitable sound fixing in the cavity area before fixing the valve. A hole of  $\varnothing 130\text{mm}$  is required to install the valve and gain access to inlet and outlet connectors. The valve needs to be mounted to the depth shown at the following centres. The distance between the 15mm inlet centre pipe centres is 150mm as shown.

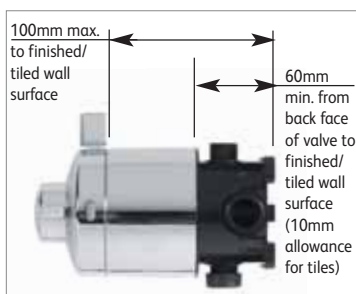
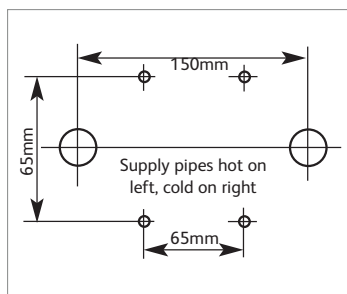

2

Mark the position for the four fixing points as outlined above.

3

Carefully remove the valve from its packaging and retain the mortar guard for later use.

4

Remove the on/off lever assembly, if fitted, from the valve by carefully pulling the assembly away from the valve (a screw is provided in the screwpack to secure the on/off lever assembly to the valve towards the end of installation).



5

Set the temperature control lever to full cold (9 o'clock) prior to removing the four screws securing the lever to the valve. Carefully remove the temperature lever to reveal the lilac temperature preset override ring and the white temperature preset location ring. Neither of these parts need to be removed for installation. However if they are removed please take a note of their orientation on the valve prior to removal (as illustrated).



6

Carefully remove the shroud from the valve assembly.



7

If the valve is being installed for use with a gas fired instantaneous (multipoint) water heater or a combination boiler, the cold water flow regulator must be fitted at this stage by insertion into the cold water port as shown (the flow regulator is supplied in its own pack).



8

Fit the elbows to the valve body hand tight, ensuring that the rubber washers are correctly engaged (these are supplied in the screw pack).

9

The Quartz Thermo valve is supplied with an outlet cap on the bottom of the valve allowing for a top outlet connection. The bottom outlet can be used by simply removing the cap and repositioning it on the top outlet. If the cap is removed please ensure that when replaced, the membrane in the cap is in place and that the cap is done up tight.

10

Fit the outlet connector ensuring the rubber washer is correctly engaged (supplied in the screwpack), on the required outlet ensuring a tight fit. Offer the valve up to the required fixing position to check the four fixings points are correct and there is adequate space available around both inlet elbows and outlet connector. Prepare the wall fixings as required.



11

Using a silicone based lubricant, lubricate the supply pipe ends and whilst supporting the elbows, push home the supply pipes ensuring the correct orientation for the inlet pipes (HOT LEFT AND COLD RIGHT AS SHOWN ON THE VALVE BODY). Push the valve fully home until a definite stop is reached (tube insertion depth is 25mm). Secure the valve assembly to the fixing surface using the screws provided.



12

Construct a suitable 15mm outlet supply to a suitable point for the wall outlet. Using a silicone based lubricant, lubricate the 15mm outlet pipe and push into the outlet assembly fully home (outlet pipe insertion depth is 24mm).

13

Using a suitable tool, tighten both the elbow nuts and outlet connector nut until water tight.

14

The installation may now be checked for leaks. Temporarily cap off the outlet supply pipe. Push the on/off lever assembly onto the front of the valve fully home and turn the knob fully clockwise to ensure the valve is fully turned off. **The on/off shaft is manufactured with a flat area. The corresponding flat area in the on/off lever must be in alignment before the knob can be fitted.**



15

Turn on the supplies and check for any leaks upstream of the valve. Slowly open the control and check for leaks downstream of the valve. If all is sound, turn off the on/off knob fully, turn off the supplies and remove the on/off lever assembly.

16

Place the mortar guard around the valve and fill in the chase. Once the in-filling material has set, carefully remove the polystyrene to expose the valve body.

**THE MORTAR GUARD MUST BE USED**



17

Refit the lilac temperature preset override ring and the white temperature preset location ring if removed prior to installation, taking care to fit the override ring in the correct orientation as outlined in step 5. Prior to replacing the shroud, ensure the shroud seal is in position as indicated.



18

Replace the shroud ensuring that it is fully fitted against the shroud support ring as shown.



19

Using a silicone based lubricant or liquid soap, lubricate the wall plate seal. Apply a thin bead of silicone mastic into the groove on the rear of the wall plate and carefully push the wall plate into position flush with the wall.



20

Depress the maximum temperature stop button and replace the temperature lever onto the valve in the full cold (9 o'clock). Replace the four screws to secure the lever to the valve hand tight only.



21

Ensuring the fixing lugs and locating pins are correctly aligned, carefully place the temperature lever cover plate onto the temperature lever and click into position.



22

Re-fit the on/off lever assembly onto the on/off shaft ensuring the corresponding flat faces are correctly aligned. Secure the on/off lever to the valve using the screw provided in the screwpack hand-tight only.





**23**

Ensuring the fixing lugs and locating pins are correctly aligned, carefully place the valve end cap onto the on/off lever and click into position.



## Adjustable height head installation

**1**

Prepare pipe work from the shower valve to the required position for the hose outlet using a  $\varnothing 15\text{mm}$  copper pipe. Slide the 15mm gripper ring down the projecting pipe up to the wall face.

**2**

Trim the projecting pipe to a length of 15-22mm using a rotary type cutter. If a hacksaw is used, the pipe end must be carefully de-burred and chamfered.

**3**

Clean and lubricate the pipe using a suitable (silicone based) lubricant.

**4**

Remove the wall outlet cover plate and carefully slide the wall outlet onto the projecting pipe. Turn to the required position and mark the screw holes on the wall face.

**5**

Remove the wall outlet and drill and prepare suitable wall fixings. Ensure the projecting pipe is clean and lubricate again if necessary. Refit the wall outlet and secure it to the wall using the screws provided.

**6**

Refit the wall outlet coverplate.



7

Drill and plug two holes 642mm-655mm vertically apart using a spirit level if necessary. Fit the rail end clip into position and loosely fit the lower bracket into position.



8

Pass the rail through the handset holder whilst keeping the slider levers depressed with the handset holder pointing in a downward direction.



9

Carefully slide the gel hook onto the rail under the handset holder.



10

Current water supply regulations state the handset should not be allowed to pass a point 25mm above the spill over level of the bath or shower tray. If this cannot be achieved, the hose must be passed through the gel hook which has also been designed to be utilised as a hose restraint.

11

Fit the rail into the rail end bodies taking care to engage the location slot onto the lugs.

12

Fit the rail end clip fitting into position into the top rail end body and secure the rail assembly to wall using the screws provided ensuring the rail and rail end bodies remain firmly engaged.



13

Place the rail end covers into position and push firmly into place.



14

Connect the hose to the wall outlet assembly after passing it through the gel hook/hose restraint (if required) and run the shower for 15 seconds without the handset attached to clear any internal debris, which may be present.



# After installation...

## Commissioning

The Quartz Thermo valve is pre-set to a safe maximum shower temperature. During use, the action of the stop button may be overridden by depressing it as the temperature control is rotated. Should it be necessary to reset the maximum temperature position please observe the following procedures.

1. Ensure that the hot water system is at normal maximum temperature.
2. Turn the temperature control lever to the full cold position (9 o'clock).
3. Carefully remove the on/off lever cap. Remove the on/off lever screw and remove the on/off lever assembly.
4. Using a screwdriver, carefully remove the temperature lever cover plate ensuring any damage to plated surfaces is avoided. Remove the temperature control lever screws and pull the temperature lever clear.
5. Carefully remove the lilac pre-set override ring and re-set in the appropriate direction to increase (clockwise) or decrease (anti-clockwise) the temperature where the override button needs to be pressed.
6. Depress the stop button and replace the temperature lever in the full cold position. Push the on/off knob into position fully home, but do not secure with the small screw at this stage.
7. Test the shower by turning it on and slowly increasing the temperature, at the selected point, the button should pop up and prevent further movement.
8. Repeat the above process if the maximum temperature stop button needs further adjustment.
9. Follow steps **20** to **23** to re-fit the temperature lever and on/off lever assembly.

# User guide



## Shower operation

Turn the on/off control fully anti-clockwise into the open position to turn the shower on.

**N.B. The on/off knob MUST NOT be used as a method of flow control.**



Rotate the temperature control lever, depressing the grey temperature limit button if required, to select a comfortable showering temperature using the temperature markings as a guide.

Turn the on/off knob fully clockwise into the closed position after use.



## Adjustable height head

To select the desired spray pattern rotate the shower spray cassette clockwise or anti-clockwise.



To select the preferred height for the shower head, depress the handset holder levers fully to enable the slider to be moved up or down the rail.



Angular adjustment is made by carefully but firmly pulling forwards or pushing back the shower head against the knuckle ratchet in the holder.

## After installation

Run through the Quartz Thermo operation with the purchaser and hand them this guide.

Complete and post the Quartz Thermo guarantee card or register online at [www.aqualisa.co.uk](http://www.aqualisa.co.uk)

## Cleaning

Your Quartz Thermo shower system should be cleaned using only a soft cloth and washing up liquid.

**DO NOT USE ABRASIVE CLEANERS.**

# Troubleshooting guide

Symptom	Possible cause	Action
Water output is either all hot or all cold, or cold only	Reversed inlet supplies	Check that the supplies correspond with the inlet markings
Water output is not hot enough	The temperature of the hot water cylinder is too low	The cylinder temperature should be at least 15°C hotter than the blend
	Water flow through the appliance is too fast	Check the flow rate recommendations with the heater manufacturer
Flow rate is poor and water temperature is low	Airlock in the water supply	Check that the pipe work is laid in accordance with the correct practices, paying particular attention to potential air-traps
Water temperature regularly swings between hot and cold	Cold water pressure is too high	If the static water pressure exceeds 7 bar (100 psi) install a pressure reducing valve (PRV) in accordance with the installation guide
	The flow regulator has not been fitted	Fit the flow regulator
Poor flow rate	Twisted hose Debris in shower head Debris in filters Debris in cold inlet flow regulator	Check and clear as necessary

# Typical installations

Typical gravity system installation

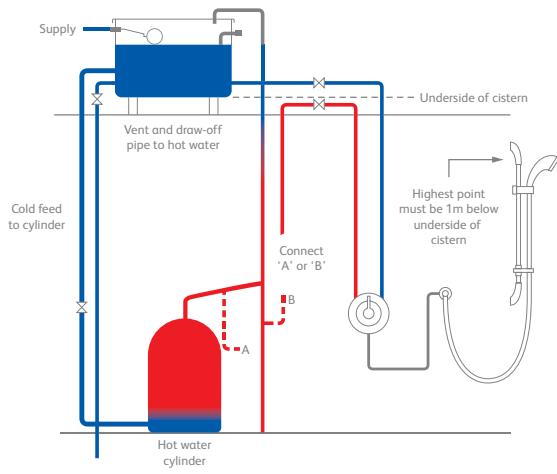

Typical Thermal storage unit system installation

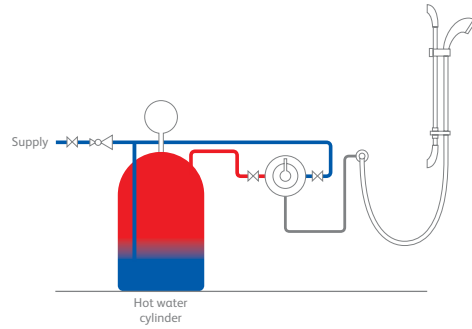

Typical pumped system installation

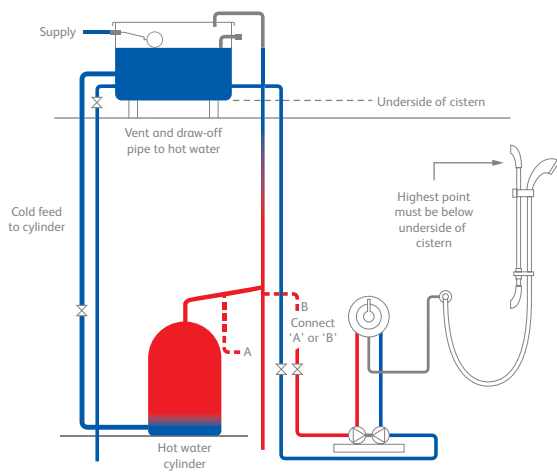

Typical UHW system installation

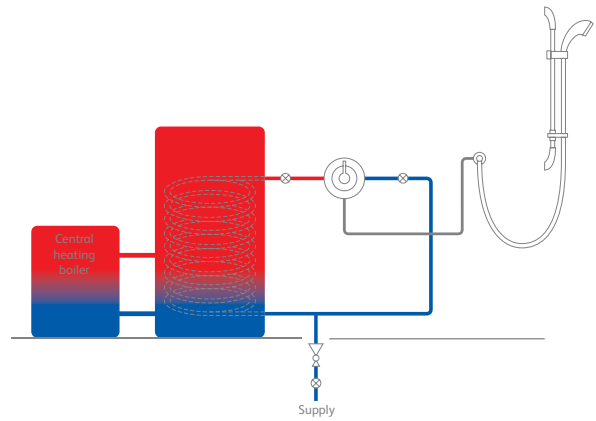

Typical combination boiler installation

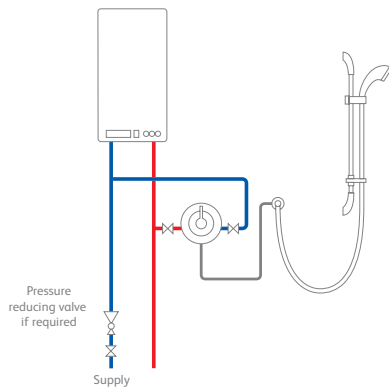



# AQUALISA

Aqualisa Products Limited  
The Flyer's Way  
Westerham Kent TN16 1DE

Sales enquiries: 01959 560010

Republic of Ireland 01-864-3363

Customer helpline: 01959 560010

Republic of Ireland 01-844-3212

Brochure Hotline: 0800 652 3669

Website: [www.aqualisa.co.uk](http://www.aqualisa.co.uk)

Email: [enquiries@aqualisa.co.uk](mailto:enquiries@aqualisa.co.uk)



Please note that calls may be recorded for training and quality purposes

The company reserves the right to alter, change or modify the product specifications without prior warning

© Registered Trademark Aqualisa Products Limited