

For more information, visit www.desatech.com

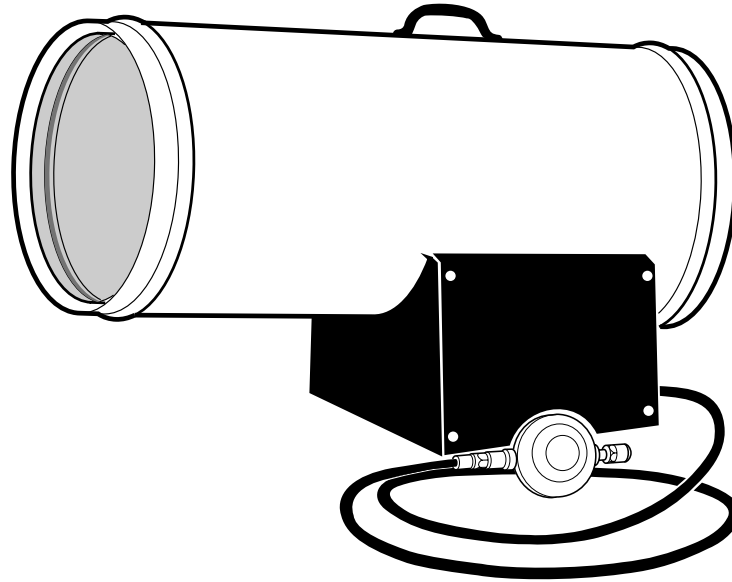

Heater Size: 375,000 Btu/Hr - AT Series

IMPORTANT: Read and understand this manual before assembling, starting, or servicing heater. Improper use of heater can cause serious injury. Keep this manual for future reference.

⚠ GENERAL HAZARD WARNING:

FAILURE TO COMPLY WITH THE PRECAUTIONS AND INSTRUCTIONS PROVIDED WITH THIS HEATER, CAN RESULT IN DEATH, SERIOUS BODILY INJURY AND PROPERTY LOSS OR DAMAGE FROM HAZARDS OF FIRE, EXPLOSION, BURN, ASPHYXIATION, CARBON MONOXIDE POISONING, AND/OR ELECTRICAL SHOCK.

ONLY PERSONS WHO CAN UNDERSTAND AND FOLLOW THE INSTRUCTIONS SHOULD USE OR SERVICE THIS HEATER.

IF YOU NEED ASSISTANCE OR HEATER INFORMATION SUCH AS AN INSTRUCTIONS MANUAL, LABELS, ETC. CONTACT THE MANUFACTURER.



TABLE OF CONTENTS

| | | | |
|------------------------------|---|--|------------|
| SAFETY INFORMATION | 2 | SERVICE PROCEDURE | 6 |
| UNPACKING | 3 | WIRING DIAGRAMS | 8 |
| PRODUCT IDENTIFICATION | 3 | SPECIFICATIONS | 8 |
| THEORY OF OPERATION | 4 | ACCESSORIES | 9 |
| PROPANE/LP SUPPLY | 4 | TECHNICAL SERVICE | 9 |
| VENTILATION | 4 | SERVICE PUBLICATIONS | 9 |
| INSTALLATION | 4 | REPLACEMENT PARTS | 9 |
| OPERATION | 5 | ILLUSTRATED PARTS BREAKDOWN AND PARTS LIST | 10 |
| STORAGE | 6 | WARRANTY INFORMATION | Back Cover |
| MAINTENANCE | 6 | | |

SAFETY INFORMATION

WARNINGS

⚠ WARNING: FIRE, BURN, INHALATION, AND EXPLOSION HAZARD. KEEP SOLID COMBUSTIBLES, SUCH AS BUILDING MATERIALS, PAPER OR CARDBOARD, A SAFE DISTANCE AWAY FROM THE HEATER AS RECOMMENDED BY THE INSTRUCTIONS. NEVER USE THE HEATER IN SPACES WHICH DO OR MAY CONTAIN VOLATILE OR AIRBORNE COMBUSTIBLES, OR PRODUCTS SUCH AS GASOLINE, SOLVENTS, PAINT THINNER, DUST PARTICLES OR UNKNOWN CHEMICALS.

⚠ WARNING: Not for home or recreational vehicle use.

The heater is designed and approved for use as a construction heater under ANSI Z83.7. The purpose of construction heaters is to provide temporary heating of buildings under construction, alteration or repair. Properly used, the heater provides safe economical heating. Products of combustion are vented into the area being heated.

We cannot foresee every use which may be made of our heaters. **Check with your local fire safety authority if you have questions about heater use.**

Other standards govern the use of fuel gases and heat producing products for specific uses. Your local authorities can advise you about these.

Carbon Monoxide Poisoning: Some people are more affected by carbon monoxide than others. Early signs of carbon monoxide poisoning resemble the flu, with headaches, dizziness, and/or nausea. If you have these signs, the heater may not be working properly. **Get fresh air at once!** Have heater serviced.

Propane/LP Gas: Propane/LP gas is odorless. An odor-making agent is added to propane/LP gas. The odor helps you detect a propane/LP gas leak. However, the odor added to propane/LP gas can fade. Propane/LP gas may be present even though no odor exists.

Make certain you read and understand all warnings. Keep this manual for reference. It is your guide to safe and proper operation of this heater.

- Install and use heater with care. Follow all local ordinances and codes. In the absence of local ordinances and codes, refer to the *Standard for Storage and Handling of Liquefied Petroleum Gas, ANSI/NFPA 58* and the *Propane Installation Code, CAN/CGA B149.2*. This instructs on the safe storage and handling of propane gases.
- Use only the electrical voltage and frequency specified on model plate. The electrical connections and grounding of the heater shall follow the *National Electric Code, ANSI/NFPA 70* or the *Canadian Electric Code, Part 1*.
- Electrical grounding instructions — This appliance is equipped with a three-prong (grounding) plug for your protection against shock hazard and should be plugged directly into a properly grounded three-prong receptacle or extension cord.
- Approved by the New York City Fire Department under certificate of Approval #4953. To be used only at construction site with applicable New York City codes, regulations, rules, directives, permits, etc.
- This product has been approved for use in the Commonwealth of Massachusetts.
- For indoor use only. Provide adequate ventilation.
- Keep heater away from strong drafts, wind, water spray, rain, or dripping water.
- Use only in well-vented areas. Before using heater, provide at least a three-square-foot opening of fresh, outside air for each 100,000 Btu/Hr of rating. This heater produces carbon monoxide, which is listed by the State of California as a reproductive toxin under Proposition 65.
- Do not use heater outdoors or in occupied dwellings.

SAFETY INFORMATION

Continued

- Do not use heater in living or sleeping quarters.
- Keep appliance area clear and free from combustible materials, gasoline, paint thinner, and other flammable vapors and liquids. Dust is combustible. Do not use heater in areas with high dust content.
- This heater is equipped with a thermostat. Heater may start at anytime.
- Check heater for damage before each use. Do not use a damaged heater.
- Use only propane/LP gas set up for vapor withdrawal.
- Keep propane tank(s) below 100° F.
- Do not use heater in a basement or below ground level. Propane/LP gas is heavier than air. If a leak occurs, propane/LP gas will sink to the lowest possible level.
- Use only the hose and factory regulator provided with the heater.
- Check hose before each use of heater. If highly worn or cut, replace with hose specified by manufacturer before using heater.
- Do not alter heater. Keep heater in its original state.
- Do not use heater if altered.
- Keep heater at least six feet from propane/LP tank(s). Do not point heater at propane/LP tank(s) within 20 feet.
- Minimum heater clearances from combustibles:
Outlet: 8 Ft. Sides: 2 Ft. Top: 6 Ft. Rear: 2 Ft.
- Locate heater on stable and level surface if heater is hot or running.
- Keep children and animals away from heater.
- Turn off propane/LP supply and unplug heater when not in use.
- Never block air inlet (rear) or air outlet (front) of heater.
- Never move, handle, or service a hot, operating, or plugged-in heater.
- Never attach duct work to front or rear of heater.
- Use only original replacement parts. This heater must use design-specific parts. Do not substitute or use generic parts. Improper replacement parts could cause serious or fatal injuries.
- Do not adjust regulator below 7 psig or above 20 psig.

UNPACKING

1. Remove all packing items applied to heater for shipment. Keep plastic cover caps (attached to inlet connector and hose/regulator assembly) for storage.
2. Remove all items from carton.
3. Check all items for shipping damage. If heater is damaged, promptly inform dealer where you bought heater.

PRODUCT IDENTIFICATION

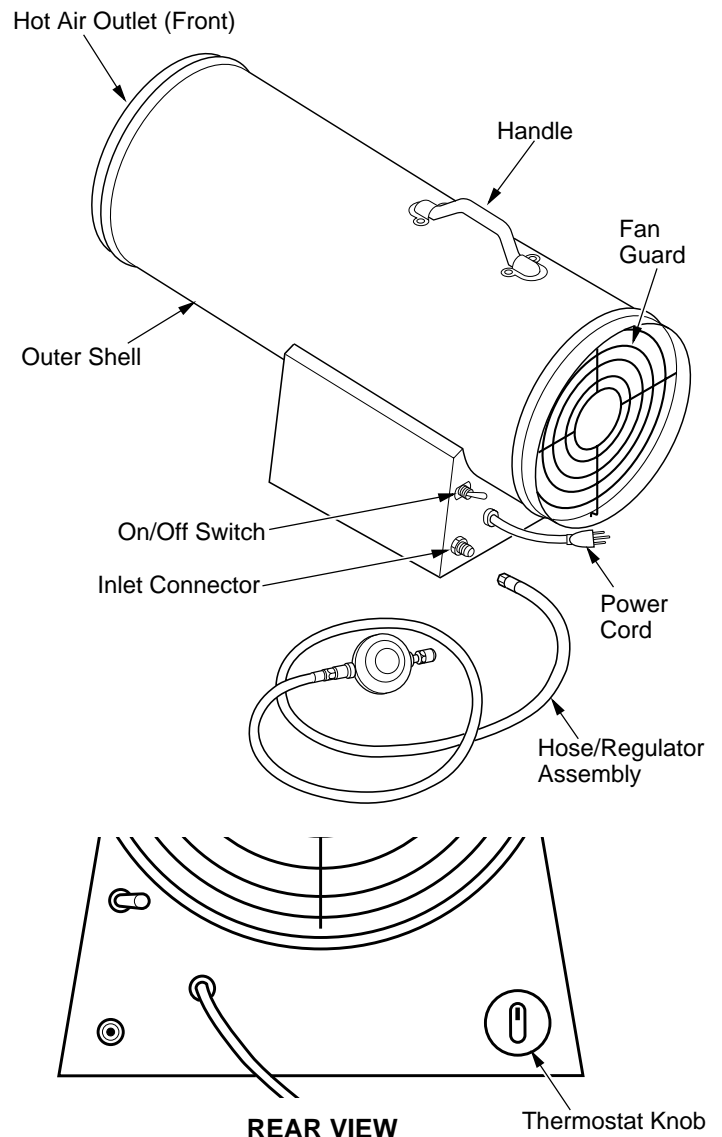

Figure 1 - 375,000 Btu/Hr Models

THEORY OF OPERATION

The Fuel System: The hose/regulator assembly attaches to the propane gas supply. The propane gas moves through the solenoid valve and out the nozzle.

The Air System: The motor turns the fan. The fan pushes air into and around the combustion chamber. This air is heated and provides a stream of clean, hot air.

The Ignition System: The direct spark ignitor (DSI) sends voltage to the ignitor. The ignitor ignites the fuel and air mixture.

The Safety Control System: This system causes the heater to shut down if the flame goes out. The motor will continue to run, but no heat is produced.

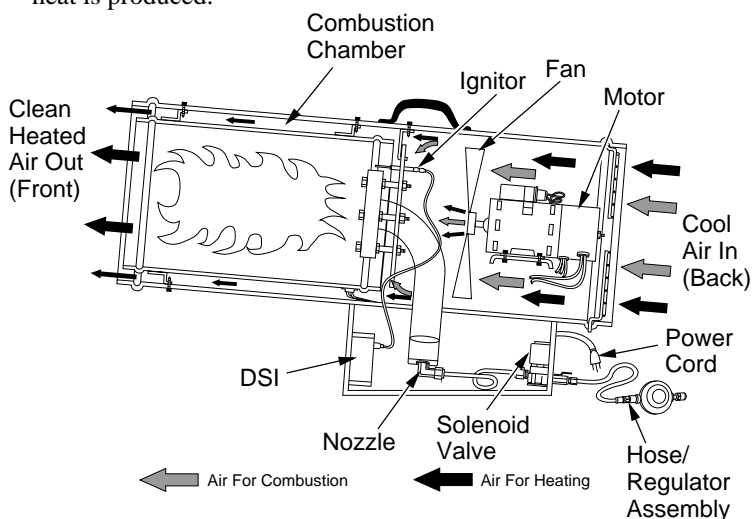

Figure 2 - Cross Section Operational View

PROPANE/LP SUPPLY

Propane/LP gas and propane/LP tank(s) are to be furnished by the user.

Use this heater only with a propane/LP vapor withdrawal supply system. See Chapter 5 of the *Standard for Storage and Handling of Liquefied Petroleum Gas, ANSI/NFPA 58* and the *Propane Installation Code CAN/CGA B149.2*. Your local library or fire department will have these booklets.

The amount of propane/LP gas ready for use from propane/LP tanks varies. Two factors decide this amount:

1. The amount of propane/LP gas in the tank(s)
2. The temperature of tank(s)

The chart below shows the number of 100-pound tanks needed to run this heater.

Do not operate this product with any tank smaller than 100 pounds.

| Temperature (°F) At Tank | |
|--------------------------|--------------------------------|
| | 40° 32° 20° 0° -10° -20° |
| Number of tanks | 3 (Use larger tank below 40°F) |

Less gas is vaporized at lower temperatures. You may need a larger tank in colder weather. Your local propane/LP gas dealer will help you select the proper supply system. The minimum surrounding air temperature rating for each heater is -20°F.

VENTILATION

WARNING: Follow the minimum fresh, outside air ventilation requirements. If proper fresh, outside air ventilation is not provided, carbon monoxide poisoning can occur. Provide proper fresh, outside air ventilation before running heater.

Provide at least three square feet of fresh, outside air for each 100,000 Btu/Hr of rating. This heater requires a fresh air opening of at least 11.25 square feet. Provide extra fresh air if more heaters are being used.

INSTALLATION

WARNING: Review and understand the warnings in the *Safety Information* section, page 2. They are needed to safely operate this heater. Follow all local codes when using this heater.

WARNING: Test all gas piping and connections for leaks after installing or servicing. Never use an open flame to check for a leak. Apply a mixture of liquid soap and water to all joints. Bubbles forming show a leak. Correct all leaks at once.

1. Provide propane/LP supply system (see *Propane/LP Supply*).
2. Connect POL fitting on hose/regulator assembly to propane/LP tank(s). Turn POL fitting counterclockwise into threads on tank. Tighten firmly using a wrench. **IMPORTANT:** Tighten regulator with black adjustment knob pointing down. Pointing adjustment knob down protects regulator from weather damage.
3. Connect hose to inlet connector. Tighten firmly using a wrench. **IMPORTANT:** Extra hose or piping may be used if needed. Install extra hose or piping between hose/regulator assembly and propane/LP tank. You must use the regulator supplied with the heater.

INSTALLATION

Continued

- Open propane/LP supply valve on propane/LP tank(s) slowly. *Note:* If not opened slowly, excess-flow check valve on propane/LP tank will stop gas flow. If this happens, you may hear a click inside the regulator assembly. To reset the excess flow check valve, close propane/LP supply valve and open again slowly.
- Adjust regulator between 7 and 20 psig (see Figure 5). *Note:* Higher regulator setting will allow heater to produce more heat.
- Check all connections for leaks.

⚠ WARNING: Do not adjust regulator below 7 psig or above 20 psig. Heater may not run properly.

- Close propane/LP supply valve.

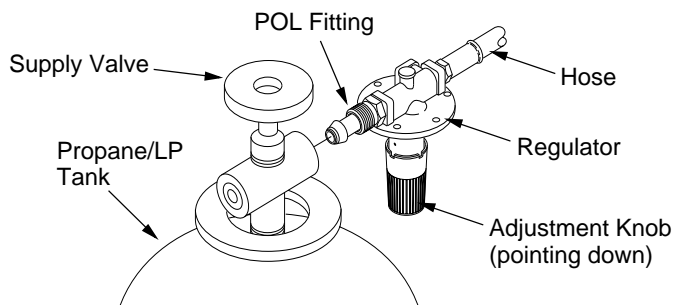

Figure 3 - Regulator With Adjustment Knob Pointing Down

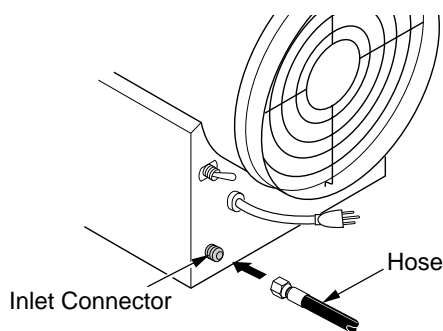

Figure 4 - Hose and Inlet Connector

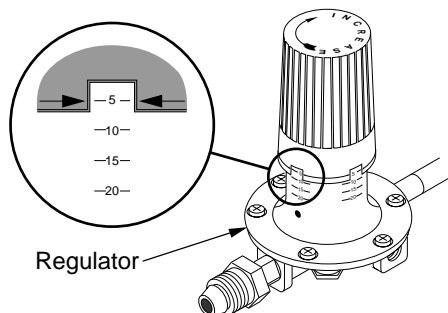

Figure 5 - Adjustable Regulator Set At 7 psig

OPERATION

⚠ WARNING: Review and understand the warnings in the Safety Information section, page 2. They are needed to safely operate this heater. Follow all local codes when using this heater.

TO START HEATER

- Follow all installation, ventilation and safety information.
- Locate heater on stable and level surface. Make sure strong drafts do not blow into front or rear of heater.
- Plug power cord of heater into a three-prong, grounded extension cord. Extension cord must be at least six feet long. Extension cord must be UL listed.

Extension Cord Size Requirement

Up to 50 feet long, use 18 AWG rated cord.

51 to 100 feet long, use 16 AWG rated cord.

101 to 200 feet long, use 14 AWG rated cord.

- Plug extension cord into a 120 volt/60 hertz, three-hole, grounded outlet.
- Open propane/LP supply valve on propane/LP tank(s) slowly. *Note:* If not opened slowly, excess-flow check valve on propane/LP tank will stop gas flow. If this happens, you may hear a click inside the regulator assembly. To reset the excess flow check valve, close propane/LP supply valve and open again slowly.
- Make sure regulator is set between 7 and 20 psig. *Note:* Higher regulator setting will allow heater to produce more heat.

⚠ WARNING: Do not adjust regulator below 7 psig or above 20 psig. Heater may not run properly.

- Turn on/off switch to the ON position. Adjust thermostat to desired setting. If heater does not start, thermostat setting may be too low. Turn thermostat knob to higher position to start heater. *Note:* If heater does not start, turn on/off switch to the OFF position. Wait ten seconds for safety control to reset, then try again.

TO STOP HEATER

- Tightly close propane/LP supply valve on propane tank(s).
- Wait a few seconds. Heater will burn gas left in supply hoses.
- Turn on/off switch to the OFF position.
- Unplug heater.

OPERATION

Continued

TO RESTART HEATER

If safety control stops gas flow to heater, motor will continue to run.

To restart heater:

1. Turn on/off switch to the OFF position.
2. Wait ten seconds, then turn on/off switch to the ON position.

If heater does not restart

- Check manual valves (if any) and supply valves (on propane/LP tank). Make sure they are open.
- Check fuel level in propane/LP tank(s). If fuel level is too low, contact local propane/LP gas company.

If heater still does not restart, contact your local service center.

STORAGE

CAUTION: Disconnect heater from propane/LP supply tank(s).

1. Store propane/LP tank(s) in safe manner. See chapter 5 of *Standard for Storage and Handling of Liquefied Petroleum Gases, ANSI/NFPA 58* and the *Propane Installation Code CAN/CGA B149.2*. Follow all local codes.
2. Place plastic cover caps over brass fittings on inlet connector and hose/regulator assembly.
3. Store in dry, clean, and safe place. Do not store hose/regulator assembly inside heater combustion chamber.
4. When taking heater out of storage, always check inside of heater. Insects and small animals may place foreign objects in heater. Keep inside of heater free from combustible and foreign objects.

MAINTENANCE

WARNING: Never service heater while it is plugged in, connected to propane supply, operating, or hot. Severe burns and electrical shock can occur.

1. Keep heater clean. Clean heater annually or as needed to remove dust and debris. If heater is dirty or dusty, clean heater with a damp cloth.
2. Inspect heater before each use. Check connections for leaks. Apply mixture of liquid soap and water to connections. Bubbles forming show a leak. Correct all leaks at once.
3. Inspect hose/regulator assembly before each use. If hose is highly worn or cut, replace.
4. Have heater inspected yearly by a qualified service agency.
5. Keep inside of heater free from combustible and foreign objects.

SERVICE PROCEDURE

WARNING: Never service heater while it is plugged in, connected to propane supply, operating, or hot. Severe burns and electrical shock can occur.

CLEANING FAN

Clean fan every 500 hours of operation or as needed.

1. Remove screws on side cover using 5/16" nut-driver.
2. Remove side cover.
3. Detach the five motor wires from parts under heater shell. Be sure to detach only wires coming from motor.

The five motor wires are:

- white wire—to terminal board
- black wire—to terminal board
- blue wire—to thermal switch wire
- orange wire—to solenoid valve
- green wire—to grounding screw on shell

4. Remove fan guard from rear of heater.
5. Reach into rear of heater shell. Carefully pull motor wires through hole in bottom of shell. **Note:** Pull wires through hole one at a time.
6. Remove nuts and mounting bolts holding motor mount to shell. Use 3/8" nut-driver and 7/16" wrench.
7. Carefully pull motor and fan out of shell. **IMPORTANT:** Be careful not to damage fan. Do not set motor and fan down with the weight resting on fan. This could damage fan pitch.

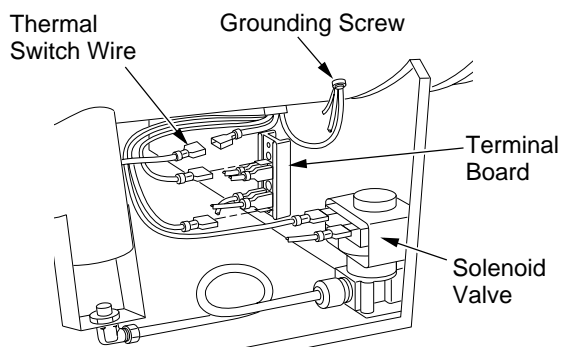

Figure 6 - Location of Motor Wires

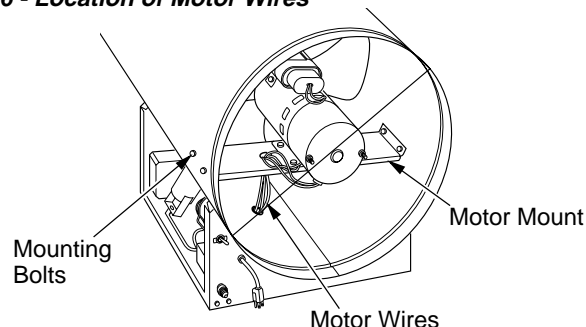

Figure 7 - Location of Fan and Motor

SERVICE PROCEDURE

Continued

8. Turn motor and fan around. Place motor and fan into shell backwards. **Note:** Motor will go into shell first (see Figure 8).
9. Line up rear mounting holes in shell with first hole on each side of motor mount (see Figure 8). **Note:** When holes are lined up, fan should be outside of shell.
10. Holding mounting bolt, carefully reach through fan blades into rear of heater. Be careful not to damage fan pitch. Insert bolt through motor mount and shell. With free hand, attach nut finger tight. Repeat process for other mounting hole.
11. Use 1/8" hex wrench to loosen setscrew which holds fan to motor shaft (see Figure 9).
12. Slip fan off motor shaft.
13. Clean fan using soft cloth moistened with kerosene or solvent.
14. Dry fan thoroughly.
15. Replace fan on motor shaft. Make sure setscrew is touching back of flat surface on motor shaft (see Figure 10).
16. Place setscrew on flat of shaft. Tighten setscrew firmly (40-50 inch-pounds).
17. Remove two nuts and bolts securing motor mount to shell.
18. Pull motor and fan from shell. Turn motor and fan around. Carefully place back in shell. **Note:** Fan will go into shell first.
19. Line up mounting holes in shell with holes on motor mount. Replace four bolts through shell and motor mount. Insert bolts from outside of heater. Tighten nuts firmly.
20. Route motor wires through hole in bottom of shell (see Figure 7, page 6).
21. Connect motor wires as follows (see Figure 6, page 6):
 - white wire—to terminal board.
Note: Attach to empty connector on white wire side of terminal board.
 - black wire—to terminal board.
Note: Attach to empty connector on black wire side of terminal board.
 - blue wire—to thermal switch wire
 - orange wire—to solenoid valve
 - green wire—to grounding screw on shell
22. Replace side cover.
23. Replace fan guard.

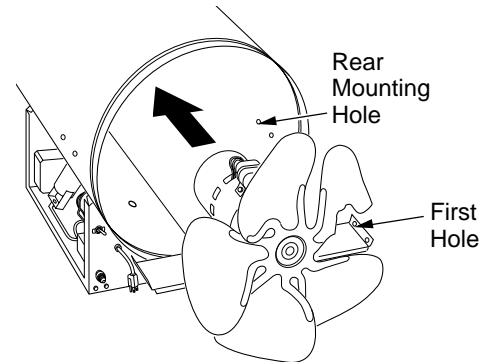

Figure 8 - Fan and Motor Turned Around

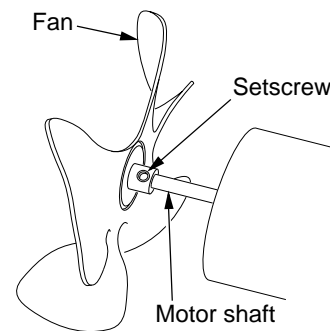

Figure 9 - Fan, Motor Shaft, and Setscrew Location

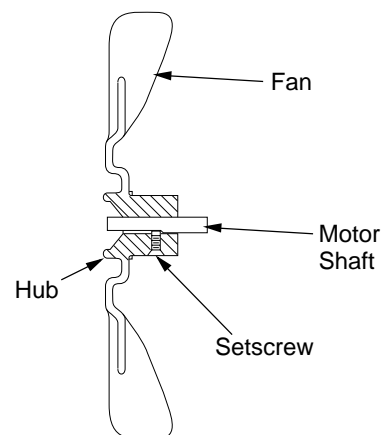

Figure 10 - Fan Cross Section

WIRING DIAGRAMS

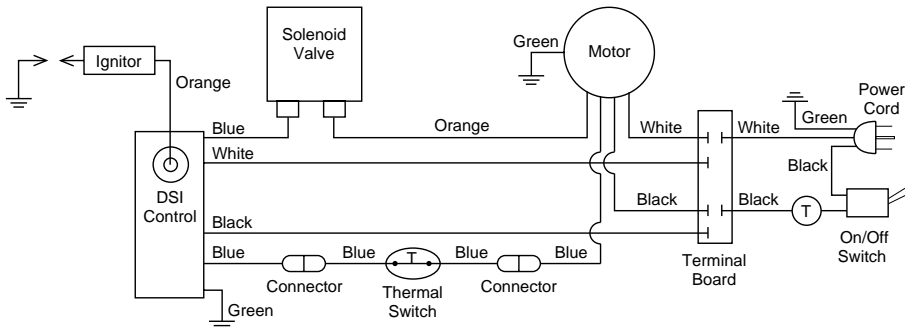

Figure 11 - Wiring Diagram

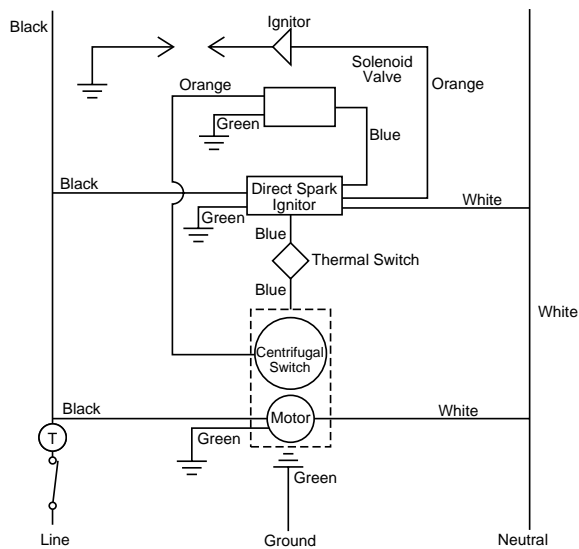

Figure 12 - Electrical Ladder Diagram

SPECIFICATIONS

| | |
|--|---------------------------|
| Output Rating (Btu/Hr) | 225,000 to 375,000 |
| Fuel | Propane/LP Vapor Only |
| Fuel Consumption | |
| Gallons/Hour | 2.5 Minimum/4.0 Maximum |
| Pounds/Hour | 10.4 Minimum/17.4 Maximum |
| Supply Pressure To Regulator | |
| Minimum (for purposes of input adjustment) | 25 psig |
| Maximum | Tank Pressure |
| Regulator Outlet Pressure | 7-20 psig |
| Hot Air Output (CFM) | 1500 |
| Motor | 1725 RPM, 1/5 HP |
| Electric Input | 120 V/60 Hz |
| Amperage | 4.2 |
| Ignition | Direct Spark |
| Weight (Pounds) | |
| Heater | 42 |
| Shipping | 49 |
| Size - L x W x H (Inches) | 34 x 13 x 19.5 |

ACCESSORIES

Purchase accessories and parts from your nearest dealer or service center. If your dealer or service center can not supply an accessory or part, either contact your nearest Parts Central (listed in the separate Authorized Service Center booklet) or call DESA International at 1-866-672-6040 for referral information. You can also write to the address listed on the back page of this manual.

Hose: LPA1020

A 10 foot hose for locating heater further away from propane/LP tank(s).

Regulator: LPA2020

Hose and Regulator Assembly: LPA3030

Fuel Gas Connector: LPA4020

A POL adapter with excess-flow check valve.

Thermostat: HA1210

TECHNICAL SERVICE

You may have further questions about this heater. If so, contact DESA International's Technical Service Department at 1-866-672-6040 or visit our website at www.desatech.com.

SERVICE PUBLICATIONS

You can receive an Illustrated Parts List free of charge. Send your request and a self-addressed, stamped envelope to DESA International (address on back page). Be sure to include the heater model number. You can purchase a service manual for \$5. Make check payable to DESA International.

REPLACEMENT PARTS

⚠ WARNING: Use only original replacement parts. This heater must use design-specific parts. Do not substitute or use generic parts. Improper replacement parts could cause serious or fatal injuries. This will also protect your warranty coverage for parts replaced under warranty.

PARTS UNDER WARRANTY

Contact authorized dealers of this product. If they cannot supply original replacement part(s), either contact your nearest Parts Central or call DESA International's Technical Service Department at 1-866-672-6040. When calling DESA International, have ready:

- your name
- your address
- model and serial numbers of your heater
- how heater was malfunctioning
- purchase date

In most cases, we will ask you to return the part to the factory.

PARTS NOT UNDER WARRANTY

Contact authorized dealers of this product. If they cannot supply original replacement part(s), either contact your nearest Parts Central or call DESA International at 1-866-672-6040 for referral information. When calling DESA International, have ready:

- model number of your heater
- the replacement part number

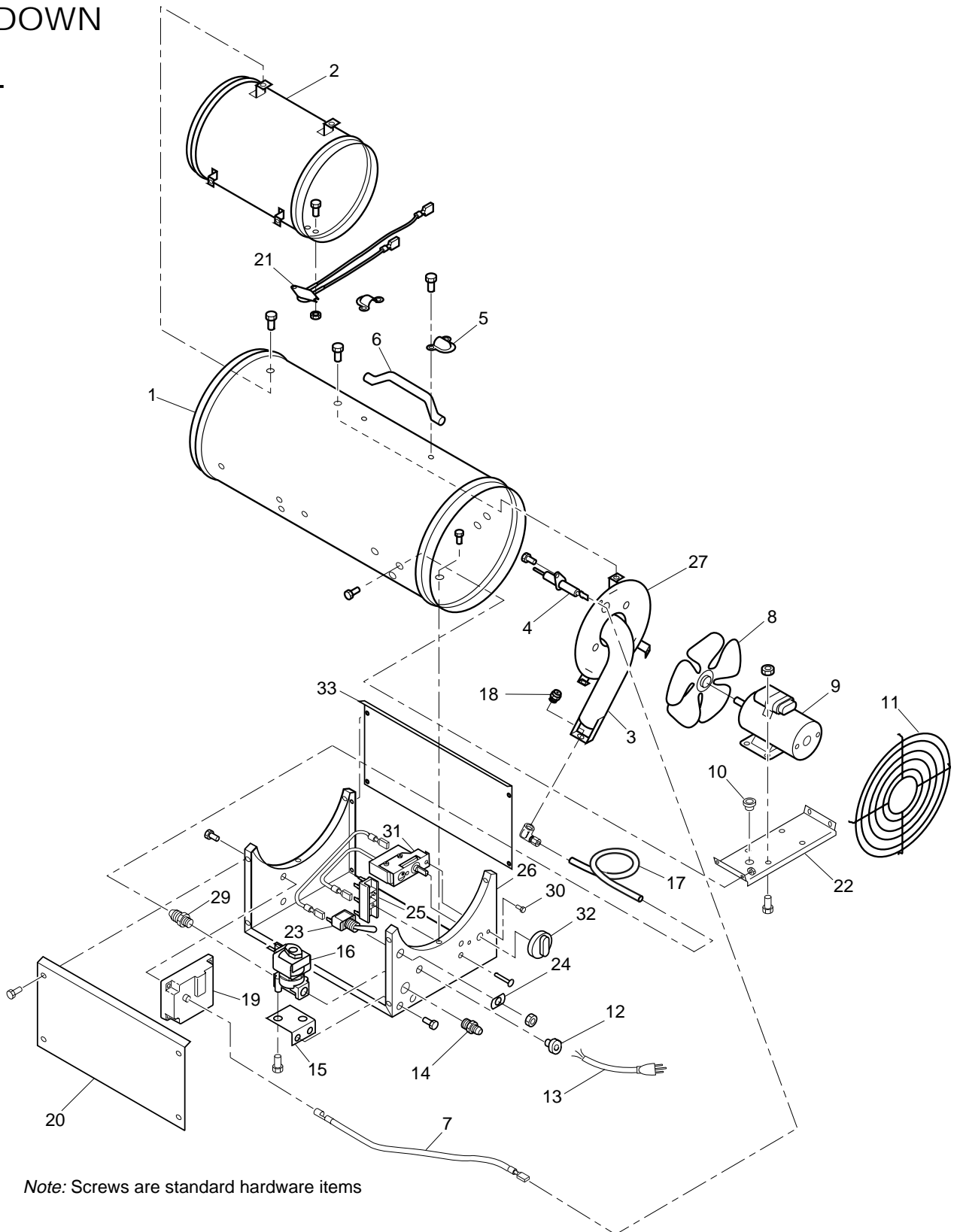
ILLUSTRATED PARTS
BREAKDOWNBLP375AT
SBLP375AT

Note: Screws are standard hardware items

PARTS LIST

This list contains replaceable parts used in your heater. When ordering parts, follow the instructions listed under *Replacement Parts* on page 9 of this manual.

BLP375AT
SBLP375AT

| KEY NO. | PART NUMBER | DESCRIPTION | QTY. |
|------------------------------------|-------------|----------------------------------|------|
| 1 | 097844-02 | Outer Shell Assembly (BLP375AT) | 1 |
| | 097844-04 | Outer Shell Assembly (SBLP375AT) | 1 |
| 2 | 097847-01 | Combustion Chamber Assembly | 1 |
| 3 | 097849-01 | Burner Assembly | 1 |
| 4 | 097805-01 | Ignitor | 1 |
| 5 | 097918-01 | Cleat | 2 |
| 6 | 097917-01 | Handle | 1 |
| 7 | 097806-02 | Ignitor Cable | 1 |
| 8 | 097811-01 | Fan | 1 |
| 9 | 097802-01 | Motor | 1 |
| 10 | M50104-02 | Shorty Bushing | 1 |
| 11 | 097838-02 | Fan Guard | 1 |
| 12 | M11143-1 | Strain Relief Bushing | 1 |
| 13 | 098219-17 | Cord Assembly | 1 |
| 14 | 097809-01 | Male Fitting | 1 |
| 15 | 097828-01 | Solenoid Bracket | 1 |
| 16 | 098201-01 | Solenoid Valve | 1 |
| 17 | 100145-01 | Fuel Tube | 1 |
| 18 | 099679-01 | Nozzle | 1 |
| 19 | M51605-02 | D.S.I. Control | 1 |
| 20 | 097833-03 | Side Cover | 1 |
| 21 | 101732-03 | Thermal Switch Kit | 1 |
| 22 | 097829-02 | Motor Mount | 1 |
| 23 | 098226-01 | On/Off Switch | 1 |
| 24 | * | Indicator Plate | 1 |
| 25 | 099125-01 | Terminal Board | 1 |
| 26 | 100408-03 | Base | 1 |
| 27 | 097848-01 | Rear Plate Assembly | 1 |
| 28 | 100146-01 | Elbow Fitting | 1 |
| 29 | 098827-01 | Compression Fitting | 1 |
| 30 | M10908-1 | Screw, Hex TPG "F" 6-32x.25 | 2 |
| 31 | 097657-03 | Thermostat | 1 |
| 32 | 104905-01 | Thermostat Knob | 1 |
| 33 | 097833-04 | Side Cover | 1 |
| PARTS AVAILABLE - NOT SHOWN | | | |
| | 103021-01 | Thermostat Decal | 1 |
| | LPA3030 | Regulator & Hose Assembly | 1 |
| | 102971-01 | Electrical Decal | 1 |
| | 103019-01 | General Information Decal | 1 |
| | 097940-08 | Tradename Decal (BLP375AT) | 2 |
| | 097940-10 | Tradename Decal (SBLP375AT) | 2 |
| | 097916-01 | Baffle | 1 |
| | LPA2020 | Regulator | 1 |
| | LPA4020 | Fuel Gas Connector | 1 |

* No Longer Available

WARRANTY AND REPAIR SERVICE

KEEP THIS WARRANTY

| |
|------------------------|
| Model _____ |
| Serial No. _____ |
| Date of Purchase _____ |

LIMITED WARRANTY

DESA International warrants this product and any parts thereof, to be free from defects in materials and workmanship for one (1) year from the date of first purchase when operated and maintained in accordance with instructions. This warranty is extended only to the original retail purchaser, when proof of purchase is provided.

This warranty covers only the cost of parts and labor required to restore the product to proper operating condition. Transportation and incidental costs associated with warranty repairs are not reimbursable under this warranty.

Warranty service is available only through authorized dealers and service centers.

This warranty does not cover defects resulting from misuse, abuse, negligence, accidents, lack of proper maintenance, normal wear, alteration, modification, tampering, contaminated fuels, repair using improper parts, or repair by anyone other than an authorized dealer or service center. Routine maintenance is the responsibility of the owner.

This Express Warranty Is Given In Lieu Of Any Other Warranty Either Expressed Or Implied, Including Warranties Of Merchantability And Fitness For A Particular Purpose.

DESA International assumes no responsibility for indirect, incidental or consequential damages. Some states do not allow the exclusion or limitation of incidental or consequential damages, or limitations or exclusions may not apply to you. This Limited Warranty gives you specific legal rights and you may also have other rights which vary from state to state.

We reserve the right to amend these specifications at any time without notice. The only warranty applicable is our standard written warranty. We make no other warranty, expressed or implied.

WARRANTY SERVICE

Should your heater require service, return it to your nearest authorized service center. Proof of purchase must be presented with the heater. The heater will be inspected. A defect may be caused by faulty materials or workmanship. If so, DESA International will repair or replace the heater without charge.

REPAIR SERVICE

Return your heater to your nearest authorized service center. Repairs not covered by the warranty will be billed at standard prices. Each Service Center is independently owned and operated. We reserve the right to amend these specifications at any time without notice.

When writing, always include model number and serial number. For information, write:

DESATM
INTERNATIONAL
2701 Industrial Drive
P.O. Box 90004
Bowling Green, KY 42102-9004
www.desatech.com



NOT A UPC

103018-01
Rev. E
03/02