

OPERATION **MANUAL**

OFFICE PRO 12 and OFFICE PRO 24

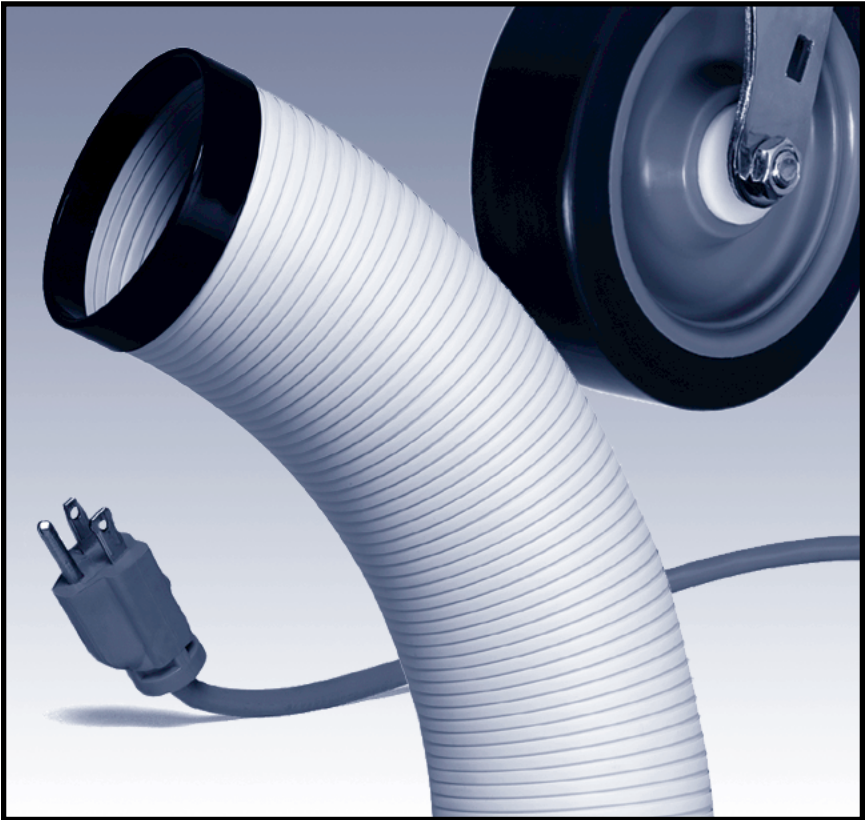

READ THIS MANUAL CAREFULLY FOR INSTRUCTIONS ON CORRECT
INSTALLATION AND USAGE, AND READ ALL SAFEGUARDS.

SECCIÓN EN ESPAÑOL
SECTION EN FRANÇAIS



MOVINCOOL.
THE PORTABLE SPOT COOLING SOLUTION

© 2003 DENSO SALES CALIFORNIA, INC.

All rights reserved. This book may not be reproduced or copied, in whole or in part, without the written permission of the publisher. DENSO SALES CALIFORNIA, INC. reserves the right to make changes without prior notice. MovinCool is a registered trademark of DENSO Corporation.

OPERATION **MANUAL**

OFFICE PRO 12 and OFFICE PRO 24



Table of Contents

FOREWORD	1
Definition of Terms	1
GENERAL WARNINGS & CAUTIONS	2
INVENTORY	3
INSTALLATION	4
Choosing an Installation Site	4
Moving the Unit	5
Plugging in the Unit	6
FEATURES	7
OPERATION	8
Control Panel	8
Operating in COOL Mode	10
Operating in Fan Only Mode	10
Changing from Fan Only Mode to COOL Mode	10
How to Set a Program	11
Operating Modes	13
Emptying the Drain Tank	14
Drain Pump Kit (Optional)	15
DAILY INSPECTION & MAINTENANCE	17
Emptying the Drain Tank	17
Cleaning the Air Filters	17
Filter Removal Method (both models)	17
Filter Cleaning Method	18
In-Season/Off-Season Inspection & Maintenance	18
TROUBLESHOOTING	19
Self-Diagnostic Codes	19
TECHNICAL SPECIFICATIONS	20
SECCIÓN EN ESPAÑOL	21
SECTION EN FRANÇAIS	45

FOREWORD

Congratulations on purchasing the MovinCool portable air conditioner.

This manual explains how to install and operate the MovinCool Office Pro 12 and Office Pro 24 portable air conditioning units. Please read this operation manual thoroughly to familiarize yourself with the features of the unit and to ensure years of reliable operation. You may also find it useful to keep this operation manual on hand for reference.

Components and/or procedures are subject to change without prior notice.

Definition of Terms

⚠WARNING: Describes precautions that should be observed in order to prevent injury to the user during installation or unit operation.

⚠CAUTION: Describes precautions that should be observed in order to prevent damage to the unit or its components, which may occur during installation or unit operation if sufficient care is not taken.

NOTE: Provides additional information that facilitates installation or unit operation.

GENERAL WARNINGS & CAUTIONS

- All electrical work, if necessary, should only be performed by qualified electrical personnel. Repair to electrical components by non-certified technicians may result in personal injury and/or damage to the unit. All electrical components replaced must be genuine MovinCool parts, purchased from an authorized reseller.
- The proper electrical outlet for MovinCool units must be equipped with a UL approved ground-fault breaker to prevent electrical shock from the unit.
- Because of potential safety hazards under a certain condition, we strongly recommend against the use of an extension cord. However, if you still elect to use an extension cord, it is absolutely necessary that it will be a UL listed, 3-wire grounding type appliance extension cord, having a 3-blade grounding plug and a 3-slot receptacle that will plug into the appliance. The marked rating of the extension cord should be 115 V, 15 A or equivalent.
- The Office Pro 12 is equipped with a ten (10) foot (3 meter) power cord. The Office Pro 24 is equipped with a six (6) foot (1.8 meter) power cord. If replacement, fixed location (hard wired) or power cord lengthening (extension cord) cords are required, contact your reseller or a qualified electrician for approved replacement methods.
- Never fold or place heavy objects on the power cord. This could result in damage to the power cord causing electrical shock or fire.
- Do not place water or any other liquid on the unit. This can cause damage to the unit and increase the risk of electrical shock.
- Do not sit or stand on the unit.

INVENTORY

After unpacking your MovinCool unit, please check to make sure you have the following items:

- Office Pro 12 or Office Pro 24 MovinCool Unit (1)
- Operation Manual/Warranty Card (1)

NOTE: If any of these items were not included in the box or appear damaged, please contact your MovinCool reseller for replacement.

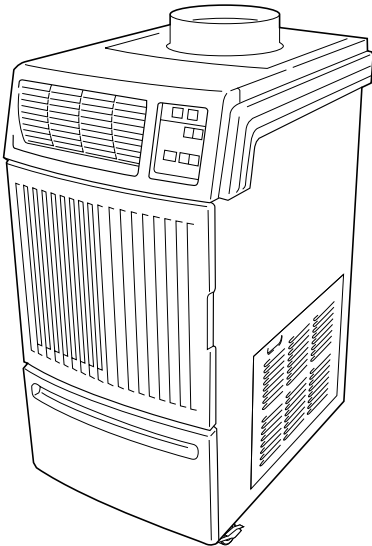

OFFICE PRO 12 MOVINCOOL UNIT

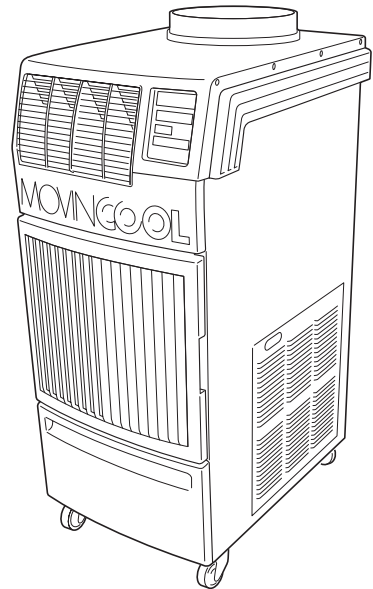

OFFICE PRO 24 MOVINCOOL UNIT



**OPERATION MANUAL /
WARRANTY CARD**

INSTALLATION

Choosing an Installation Site

⚠CAUTION: Following are some precautions to consider before choosing your installation site. Please review carefully as improper installation may result in personal injury or damage to the unit.

- Do not use the unit in areas where leakage of flammable gas may occur.
- Do not use the unit in areas where it will be exposed to rain or water.
- Do not use the unit in an atmosphere of excessively corrosive gas or vapor.
- Do not use in areas where the temperature is outside the allowable operating range.
- Do not install the unit in sloping areas. The unit may move or topple over even if the casters are set to the LOCKED position.
- Install the unit in areas that can withstand the weight of the unit. The Office Pro 12 unit weighs approximately 200 lbs (91 kg) and the Office Pro 24 weighs approximately 245 lbs. (111 kg) (when the drain tank is full of water).
- Allow 18 inches of unobstructed airflow for both the air inlets and outlets.
- Do not use the unit above 95°F 50% RH.

INSTALLATION (cont.)

Moving the Unit

Unlock the casters and push the MovinCool unit using the side handles to a flat, level surface and set the casters back to the LOCKED position.

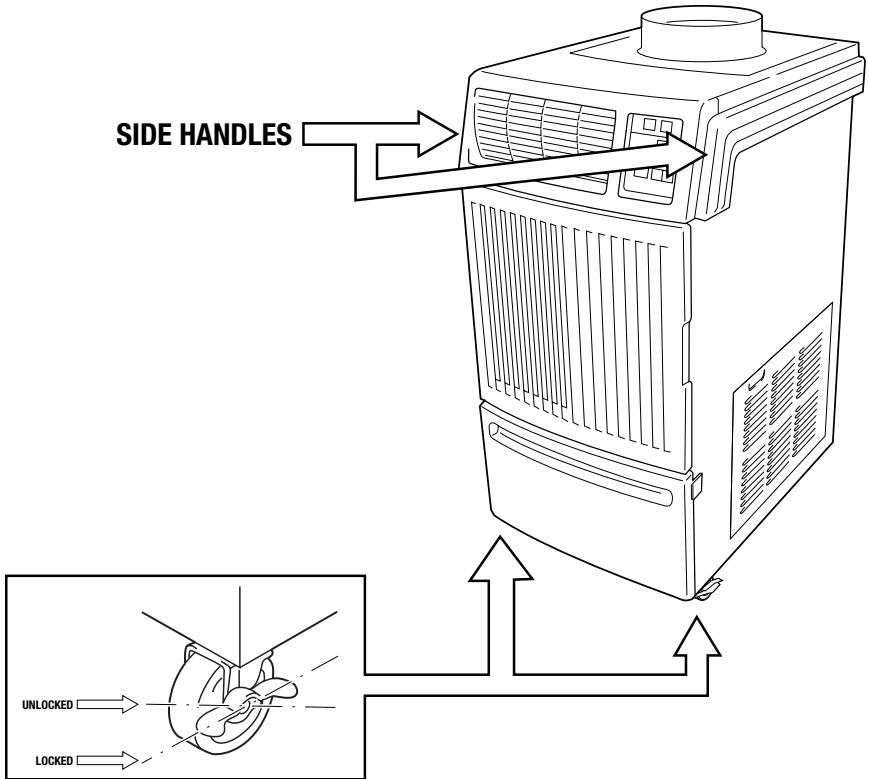

INSTALLATION (cont.)

Plugging in the Unit

- Check the prongs and surface of the power cord plug for dust/dirt. If dust and/or dirt are present, wipe off with a clean, dry cloth.
- Check the power cord, plug and prongs for damage or excess play. If any damage or excess play is found, contact your MovinCool reseller for repair.
- For the Office Pro 24 model, fully insert plug into the A/C outlet and rotate clockwise until it locks in place.

⚠WARNING:

- **If the power cord or plug is damaged, repair should only be performed by qualified electrical personnel.**
- **Do not connect/disconnect the power cord or attempt to operate buttons with wet hands. This could result in electrical shock.**

⚠CAUTION:

- **Office Pro 12 model ONLY: The AC outlet (115 VAC Single Phase, 60Hz) needs to be rated at 15A or higher. Do not share the outlet with any other instrument or equipment.**
- **Office Pro 24 model ONLY: The AC outlet (208/230 VAC Single Phase, 60Hz) needs to be rated at 20A or higher. Do not share the outlet with any other instrument or equipment.**

NOTE:

- ***Make sure the AC outlet is free of dirt, dust, oil, water, or any other foreign matter.***
- ***The Office Pro 12 model is equipped with an approved NEMA plug configuration (L5-15). The appropriate outlet must be used for this plug type.***
- ***The Office Pro 24 model is equipped with an approved NEMA plug configuration (L6-20). The appropriate outlet must be used for this plug type.***

FEATURES

Both Models feature:

- An electronic control panel, which allows the user to control the unit's operation easily.
- Dual fan speeds (either HIGH or LOW) in both COOL and Fan Only modes.
- Digital display that indicates the temperature SET POINT (either Fahrenheit or Celsius) in which the COOL Mode will operate in. This is also the temperature the units will try to maintain. The Temperature SET POINT can be adjusted between 65°F and 95°F by the SET TEMP buttons (▼/▲).
- A condensate drain TANK FULL indicator display (LED).
- An automatic restart feature when the power is lost and regained. The unit will return to the operating mode it was in prior to the loss of power. Any preset program will be retained in the memory in the event power loss occurs.
- A programmable Clock/Timer function. This allows the user to program a specific time of day that the unit will begin to operate/start and turn off/end (Automatic Operation).
- A two-digit room temperature display.

OPERATION

Control Panel

Before operating the unit, it is important to familiarize yourself with the basic controls located on the control panel.

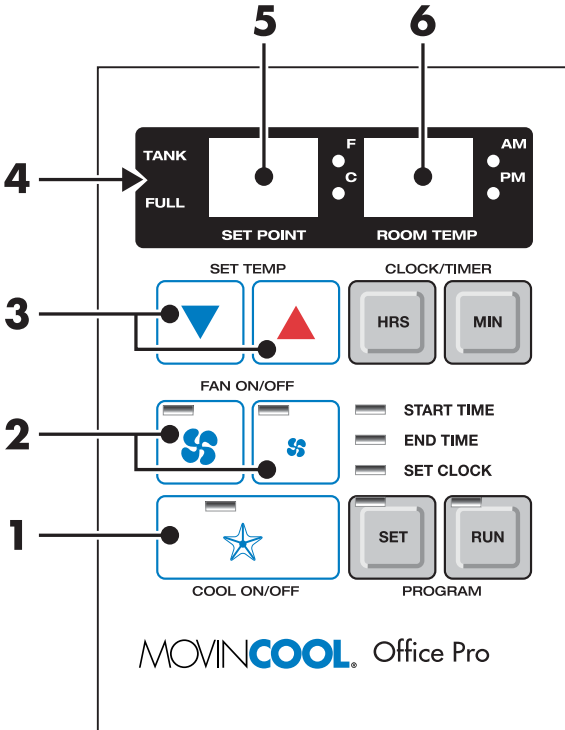

- | | | |
|---|------------------------|--|
| ① | COOL ON/OFF Button | Activates/deactivates the COOL mode/ turns the unit off. |
| ② | FAN ON/OFF Buttons | Activates/deactivates the HIGH or LOW fan mode. |
| ③ | SET TEMP Buttons (▼/▲) | Increases/decreases the temperature set point. |
| ④ | TANK FULL LED | Flashes when the drain tank is full. |
| ⑤ | SET POINT Display | Indicates the current temperature set point; also used to display clock hour when programming. |
| ⑥ | ROOM TEMP Display | Indicates the current room temperature; also used to display the clock minutes when programming. |

OPERATION (cont.)

Control Panel (Cont.)

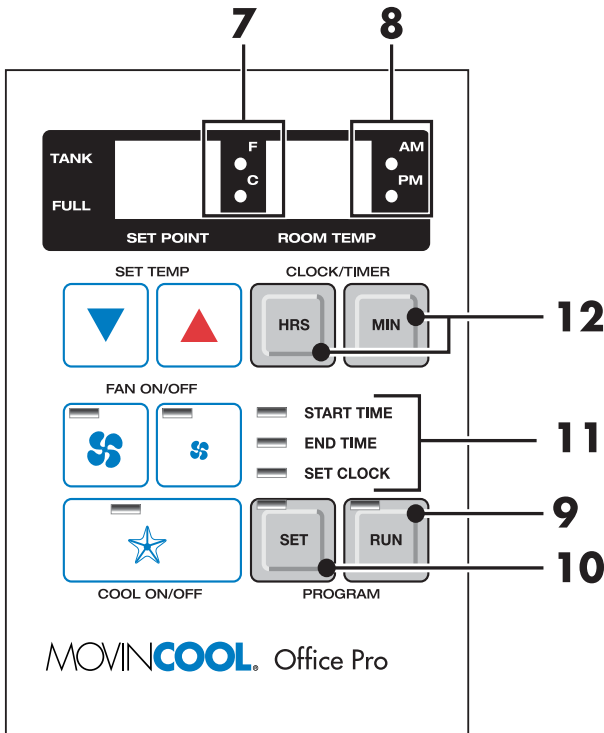

- ⑦ Temperature Scale LED
Illuminates to indicate the current temperatures being displayed are either in °C or °F; also displays the clock when programming.
- ⑧ **AM/PM** LED
Illuminates to indicate AM or PM time of day.
- ⑨ Program **RUN** Button
Activates/deactivates a program.
- ⑩ Program **SET** Button
Allows the user to program the unit or check the current program.
- ⑪ **START TIME LED**
END TIME LED
SET CLOCK LED
Illuminates to indicate the current step that is being programmed into the unit.
- ⑫ CLOCK/TIMER Buttons
Allows the user to set the clock and program the start and end time of operation.

OPERATION (cont.)

Operating in COOL Mode

- ① The unit can be operated in COOL mode by pressing the COOL ON/OFF button (LED illuminates).

NOTE: In COOL mode the unit can only be turned off by pressing the COOL ON/OFF button again, not by pressing the fan buttons.

- ② Change the fan speed by pressing the HIGH or LOW fan buttons.
- ③ Change the temperature set point by pressing the SET TEMP buttons (▼/▲).

NOTE: When turning the unit on, the set point and fan speed are determined by the last operating mode (program mode not included).

Operating in Fan Only Mode

- ① The unit can also be operated in Fan Only mode by pressing either the HIGH or LOW fan buttons (LED illuminates).
- ② The unit can then be turned off by pressing the fan speed button that is illuminated.

Changing from Fan Only Mode to COOL Mode

The COOL mode can be activated while the unit is operating in Fan Only mode. To do this, simply press the COOL ON/OFF button (LED illuminates).

NOTE: The Fan Only mode will not operate after the COOL mode has been activated. After the COOL mode has been activated, the unit cannot be turned off by pressing the fan buttons. The COOL ON/OFF button must be pressed.

OPERATION (cont.)

How to Set a Program

① **Setting a START TIME**

Press the Program SET button. The Program SET button and **START TIME** LEDs will illuminate. Press the HRS and MIN buttons to set the START TIME.

② **Setting an END TIME**

Press the Program SET button until the **END TIME** LED illuminates. Press the HRS and MIN buttons to set the END TIME.

③ **Setting the CLOCK TIME**

Press the Program SET button until the **SET CLOCK** LED illuminates. Press the HRS and MIN buttons to set the current clock time into the unit.

NOTE: The AM/PM LED will change with the HRS button.

④ **Programming the Temperature SET POINT**

Press the Program SET button until the current SET POINT temperature display begins to flash on and off. Select a new desired SET POINT temperature (65°F – 95°F) by pressing the SET TEMP buttons (▼/▲).

⑤ **Programming the Fan Speed**

Press the Program SET button until one of the Fan Speed button LEDs (HIGH/LOW) begin to flash. This is the current programmed Fan Speed. To change the programmed Fan Speed, simply press the other Fan Speed button.

⑥ **Exiting the Program SET Function**

After changing any of the above settings, continue pressing the Program SET button until the Program SET button LED turns off. The unit will then return to the previous mode.

⑦ **Activating/Deactivating a Preset Program**

Press the Program RUN button to activate/deactivate a preset program. The Program **RUN** LED will illuminate when activated.

OPERATION (cont.)

How to Set a Program (Cont.)

NOTE:

- *The unit will return to the previous mode if a program is turned off while it is running.*
- *The Program RUN LED flashes while a program is running. It is illuminated continuously when the program mode is activated.*
- *While a program is running, the program can only be stopped by pressing the Program RUN button. All other buttons are inoperable when a program is running.*
- *The unit returns to the previous mode at the end of a program.*
- *The unit does not have to be running to set a program.*
- *During programming, the unit returns to the previous mode if no activity occurs within approximately 35 seconds.*

OPERATION (cont.)

Operating Modes

Both Office Pro models operate in two modes, Fan Only and COOL. When in Fan Only mode, the unit circulates the surrounding air. When in COOL mode, the compressor is operational and cool air is circulated.

- **COOL Mode**

Both models will operate in Fan Only mode for approximately 90 seconds before the compressor engages. (Time delay setting is 90 ± 15 seconds.)

- **Temperature Control**

The room temperature thermistor allows the unit to switch automatically between COOL and Fan Only modes. This is dependent upon inlet air temperature versus SET POINT temperature.

- **Fan Mode Control DIP Switch**

The Fan Mode Control DIP Switch determines whether the FAN will continue to operate or stop when the compressor cycles off. (SET POINT temperature equals inlet air or room temperature.) The unit has been preset at the factory for continuous fan operation.

- **Temperature Scale Display DIP Switch**

The Temperature Scale Display DIP Switch changes the temperature(s) that are displayed to either °C or °F. The unit has been preset from the factory to display the temperature(s) in °F.

NOTE: If you wish to change the fan mode operation (COOL ⇔ OPERATE to COOL ⇔ STOP), and/or the Temperature Scale Display (°F to °C), contact your MovinCool reseller.

OPERATION (cont.)

Emptying the Drain Tank

During COOL mode, condensate will accumulate in the drain tank. When the drain tank becomes full, the **FULL TANK** LED will flash and the unit will shut off automatically.

NOTE: If you want to empty the drain tank, while the unit is in operation, press the **COOL ON/OFF** button to turn the unit off. If a program is running, you must first press the **Program RUN** button.

① Open the drain tank lid.

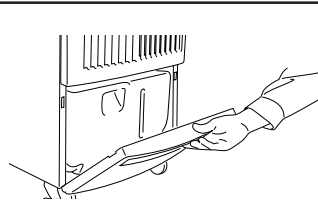

② Pull the drain tank from the unit.

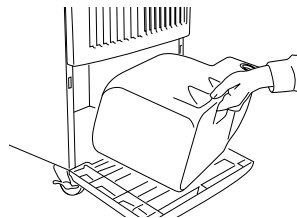

③ Remove the cap and empty the drain tank.

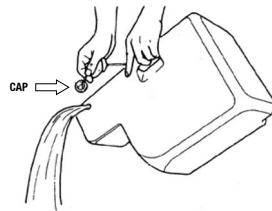

④ Replace the cap and return the drain tank to the unit.

⑤ Close the drain tank lid.

⑥ If the Program **RUN** LED is flashing, press the **COOL ON/OFF** button to continue running the program. If the Program **RUN** LED is illuminated continuously, no further steps are necessary. If no program exists or the program was deactivated, press the **COOL ON/OFF** button to restart the unit.

OPERATION (cont.)

Drain Pump Kit (Optional) (Office Pro 12 model ONLY)

A drain pump kit (CPK-3) is available to allow continuous operation and to eliminate the need for a drain tank.

- When the water collects to level (A) in the pump reservoir, the drain pump begins to operate and discharges the water.

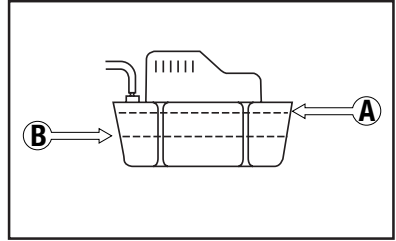

NOTE: The compressor will not operate while the drain pump is discharging water.

- When the water level drops below level (B), the drain pump stops, and the compressor will restart.

NOTE: If for any reason the water level exceeds that of level (A) in the pump reservoir, an overflow Drain Switch will stop the compressor operation.

NOTE: If the Fan Mode Control DIP Switch (see pg. 13) is set to the STOP position, the entire unit (including fan operation) will turn off whether due to the overflow Drain Switch or while the drain pump is discharging water.

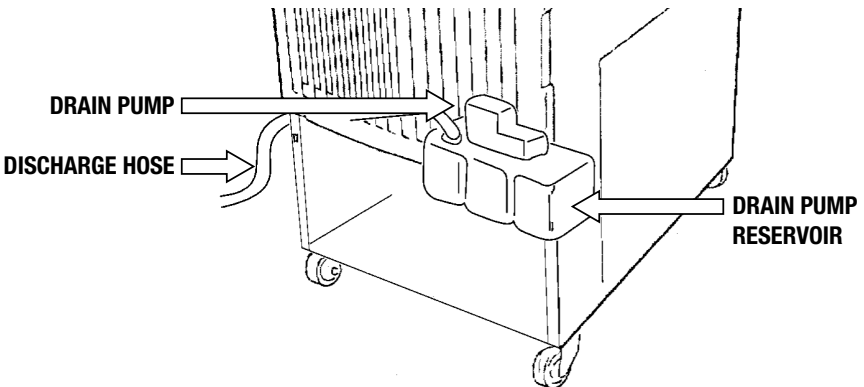

OPERATION (cont.)

DRAIN PUMP KIT (Optional) (Office Pro 24 model ONLY)

A drain pump kit (CPK-5) is available to allow continuous operation and to eliminate the need for a drain tank.

- When the water collects to level (A) in the pump reservoir, the drain pump begins to operate and discharges the water.
- When the water level drops below level (B), the drain pump will stop.



NOTE: If for any reason the water level exceeds that of level (A) in the pump reservoir, an overflow Drain Switch will stop the compressor operation.

NOTE: If the Fan Mode Control DIP Switch (see pg. 13) is set to the STOP position, the entire unit (including fan operation) will turn off due to the overflow Drain Switch.

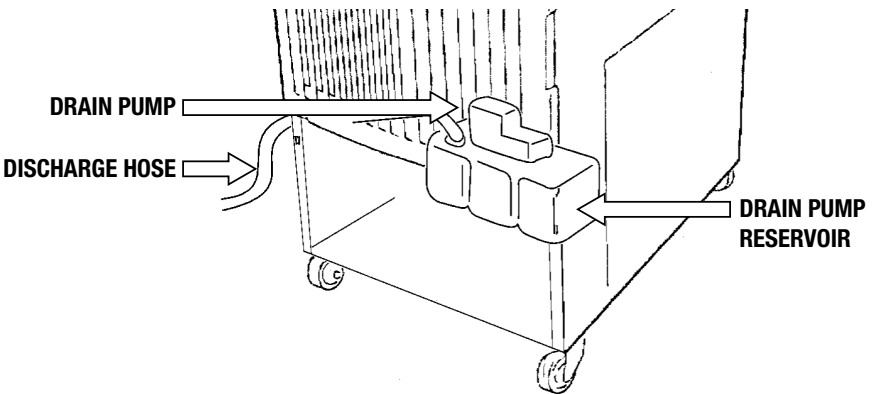

DAILY INSPECTION & MAINTENANCE

Emptying the Drain Tank

To empty the drain tank, refer to instructions on page 14.

Cleaning the Air Filters

Clean the air filters once a week. If the unit is used in a dusty environment, more frequent cleaning may be required.

A dirty air filter reduces air output resulting in a decrease of the cooling capacity.

Filter Removal Method (both models)

- ① Turn the unit off by pressing the COOL ON/OFF button. If a program is running, you must first press the Program “RUN” button.
- ② Remove the two air filters.

NOTE: To remove the filters from the Office Pro models, open the front panel and side panel filter doors. On the front panel door, carefully remove the filter retainer from its clips by pulling on the retainer at those two points. On the side panel door, carefully remove the filter element from the Velcro® attachment points.

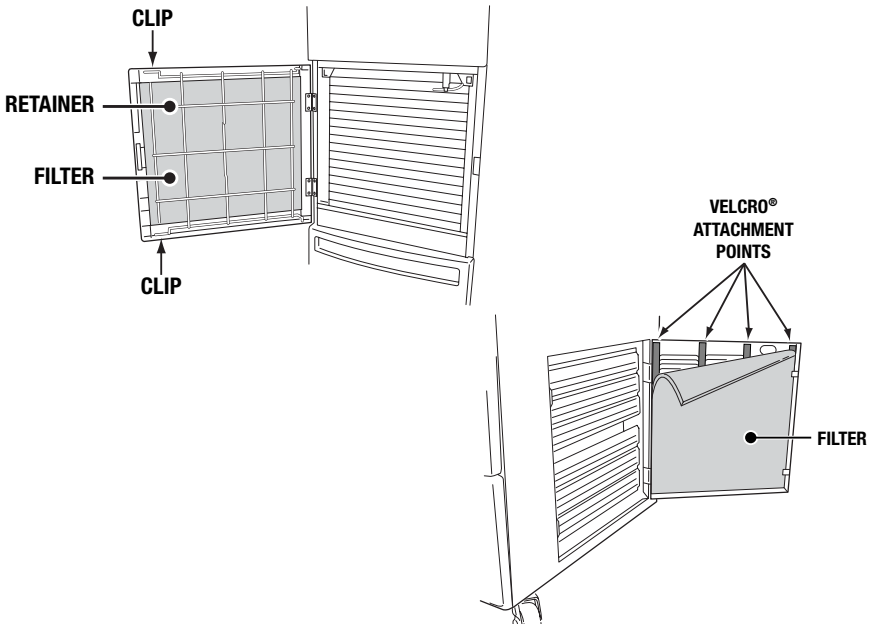

DAILY INSPECTION & MAINTENANCE (cont.)

Filter Cleaning Method

- ① Remove dust from the element with a vacuum cleaner, or rinse in cold or lukewarm water. If the element is extremely dirty, wash with a neutral detergent.
- ② After the element has been cleaned, rinse with clean running water, allow to dry, then reinstall.

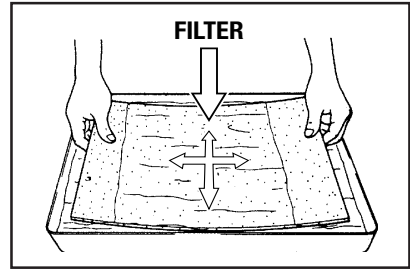

In-Season/Off-Season Inspection & Maintenance

■ In-Season

- ① Check the prongs and surface of the power cord plug for dust and/or dirt. If dust and/or dirt are present, wipe off with a clean, dry cloth.
- ② Check the power cord, plug and prongs for damage or excess play. If any damage or excess play is found, contact your MovinCool reseller for repair.
- ③ Check the air filters and drain tank.
- ④ Clean the outside of the unit(s) with a damp cloth or mild nonabrasive cleaner.

■ Off-Season

- ① Operate the unit in Fan Only mode for 8 hours.

Note: Operation is necessary to dry out the inside of the unit.

- ② Disconnect the power cord from the AC outlet.
- ③ Check the prongs and surface of the power cord plug for dust and/or dirt. If dust and/or dirt are present, wipe off with a clean, dry cloth.
- ④ Check the power cord, plug and prongs for damage or excess play. If any damage or excess play is found, contact your MovinCool reseller for repair.
- ⑤ Clean the air filters.
- ⑥ Empty all water from the drain tank.

TROUBLESHOOTING

Self-Diagnostic Codes

Self-Diagnostic Codes will be displayed on the Control Board under the following conditions:

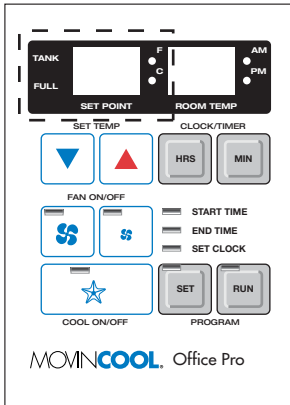

Code Condition

- dF When the evaporator thermistor disengages the compressor.
- FL When the drain tank switch shuts off the unit (**FULL TANK** LED flashes).
- AS When unit disengages the compressor while the condensate pump is discharging water.
- HP When the high pressure switch disengages the compressor.
- LO Lowest temperature set point.
- HI Highest temperature set point.

Check the following points before calling a qualified technician.

SYMPTOM	POSSIBLE CAUSE	REMEDY
<i>Unit does not operate</i>	<ol style="list-style-type: none"> ① Ground fault breaker tripped ② Drain tank is full (FULL TANK LED will be flashing) 	Reset breaker Empty the drain tank
<i>Insufficient cooling</i>	<ol style="list-style-type: none"> ① Dirty/blocked air filters ② Air inlet/outlet blocked ③ Improper temperature setting 	Clean air filters Clear air inlet/outlet Set to desired position

If symptoms persist after the above actions have been taken, turn the unit off, disconnect the power cord plug and contact your MovinCool reseller.



LIMITED WARRANTY

DENSO SALES CALIFORNIA, INC. ("DENSO") warrants its MOVINCOOL Products only to the extent stated in its official written warranties. Unless otherwise specifically provided in writing by DENSO, DENSO warrants to end-user that the Products shall be free of defects in materials or workmanship and will function in accordance with DENSO's published specifications under ordinary intended use and service for a period of twelve (12) months after delivery to the end-user; provided, however, in the case of the compressor element of the Products such warranty shall be for a period of thirty six (36) months after delivery to the end-user. DENSO shall, at its sole option, repair or replace any defective Product covered by this warranty. Such remedy shall be end-user's sole remedy with respect to any particular defect in the Products.

This warranty does not cover defects or malfunctions which result from causes beyond DENSO's control, including, without limitation, (i) unusual physical or electrical stress; (ii) accident, neglect, abuse, misuse or other abnormal use; (iii) failure to perform routine maintenance in accordance with DENSO'S recommended procedures; (iv) normal wear and tear; (v) repairs or attempted repairs by an unauthorized person; (vi) modifications or alterations to the Products; (vii) use with supplies or devices not supplied or approved by DENSO; or (viii) improper servicing. This warranty shall extend only to the original end-user and shall be void if any labels or other identifying marks permanently affixed to Products when shipped by DENSO are removed, altered, defaced or obliterated.

The aforesaid warranty is the only warranty made by DENSO with respect to the Products and is in lieu of all obligations or liabilities on the part of DENSO for damages arising out of or in connection with the sale, use or performance of the Products, including, without limitation, any lost profits or any other consequential, incidental, special or exemplary damages of any kind. DENSO DISCLAIMS ALL OTHER WARRANTIES WITH REGARD TO THE PRODUCTS, INCLUDING ALL IMPLIED WARRANTIES OF MERCHANTABILITY AND FITNESS FOR USE. THERE ARE NO WARRANTIES WHICH EXTEND BEYOND THE DESCRIPTION CONTAINED HEREIN.

PURCHASE DATE: _____

SERIAL NUMBER: _____

↓ DETACH HERE ↓

MOVINCOOL. REGISTRATION CARD

OWNER INFORMATION

Company _____
 Contact _____
 Title _____
 Address _____
 City/State/Zip _____
 Phone _____ FAX _____
 E-Mail _____

Date of Purchase _____

Model No. (check one)

- Classic 10
- Classic 18
- Classic 40
- Classic 60
- Classic Plus 14
- Classic Plus 26

- Office Pro 10
- Office Pro 12
- Office Pro 18
- Office Pro 24
- Office Pro 60

Serial No. (on side panel) _____

DEALER NAME _____

DEALER LOCATION _____

What is your type of business?

- Banking/Finance
- Education
- Government/Military
- Hospital/Healthcare
- Restaurant/Foodservice
- Sales/Marketing
- Manufacturing-plastics
- Manufacturing-metals
- Manufacturing-paper/wood products
- Manufacturing-electronics/electrical components
- Manufacturing-other
- Utility

How did you first hear about MovinCool?

- Magazine Ad
- Magazine Article
- Direct Mail
- Postcard Deck
- Trade Show
- Referral
- Other _____

What factors most influenced your decision to purchase a MovinCool?

- Product Quality
- Price
- Portability
- Ease of Installation
- Energy Savings
- Versatility

Have you previously purchased a MovinCool?

- Yes
- No

If yes, how many units do you own? _____

What is the primary use for this unit?

- Cooling people
- Cooling equipment
- Cooling a process
- Other _____

Where is the unit used?

- Office
- Manufacturing or Warehouse
- Hospital/Laboratory
- Computer/Equipment Room
- Kitchen/Laundry
- Special Events/Outdoors
- Other _____

Comments _____

DENSO

DENSO SALES CALIFORNIA, INC.

3900 Via Oro Avenue

Long Beach CA 90810-1868

800-264-9573 / 310-834-6352

www.movincool.com

Technical Services Department

DSCA P/N: LA990009-1218

GAC P/N: LA484007-1421

Fourth Issue: April 2003

Printed in the U.S.A.



BUSINESS REPLY MAIL

FIRST-CLASS MAIL PERMIT NO. 8390 LONG BEACH, CA

POSTAGE WILL BE PAID BY ADDRESSEE

NO POSTAGE
NECESSARY
IF MAILED
IN THE
UNITED STATES

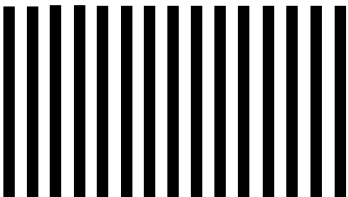

MOVINCOOL[®]

Pioneering New Solutions With Portable Air-Conditioning

DENSO SALES CALIFORNIA, INC.

3900 VIA ORO AVENUE

LONG BEACH CA 90810-9969

